

Dannmar Equipment
646 Flinn Avenue, Suite A
Moorpark, CA 93021
Tel: 1-877-432-6627
www.dannmar.com



D-9/X USER MANUAL

TWO-POST LIFT
9,000 POUND CAPACITY
FLOOR PLATE

Also known as Admiral 9000X



Rev C 07012016
P/N# 199822



Reference ANSI/ALI ALIOM safety requirements for installation and service of automotive lifts before installing lift.



PLEASE READ THE ENTIRE CONTENTS OF THIS MANUAL PRIOR TO INSTALLATION AND OPERATION. BY PROCEEDING WITH LIFT INSTALLATION AND OPERATION YOU AGREE THAT YOU FULLY UNDERSTAND AND COMPREHEND THE FULL CONTENTS OF THIS MANUAL. FORWARD THIS MANUAL TO ALL OPERATORS. FAILURE TO OPERATE THIS EQUIPMENT AS DIRECTED MAY CAUSE INJURY OR DEATH.

TABLE OF CONTENTS

IMPORTANT NOTICE	3
DEFINITIONS OF HAZARD LEVELS	3
IMPORTANT SAFETY INSTRUCTIONS	4
OWNER / EMPLOYER RESPONSIBILITIES	6
PARTS LIST	8
ASSEMBLY DIAGRAM	9
INSTALLATION INSTRUCTIONS	10
CONCRETE SPECIFICATIONS	11
CABLE ROUTING DIAGRAM	13
HOSE ROUTING DIAGRAM	15
WIRING THE POWER UNIT	16
LIFT ARM INSTALLATION	17
POST INSTALLATION CHECK OFF	20
LUBRICATION POINTS	20
OPERATION INSTRUCTIONS	20
MAINTENANCE INSTRUCTIONS	25
WIRE ROPE INSPECTION AND MAINTENANCE	27
LIFT LOCKOUT / TAGOUT PROCEDURE	28
REQUIRED SAFETY LABELS	29
OPERATIONAL TEST PROCEEDURE	31
TROUBLESHOOTING GUIDE	33
WARRANTY INFORMATION	37

PRODUCT SPECIFICATIONS

MODEL	D-9/X
Maximum Lift Capacity	9,000-lb.
Power Unit	220V, 60Hz, 30 Amp, Single phase
Max. Lifting Height	76"
Min. Pad Height	6"
Hydraulic Oil Capacity/Type	12 qts. AW-32 or Dexron III or VI
Overall Dimensions	113" H x 145" W
Shipping Weight	1465 lb.

IMPORTANT NOTICE

1. Read this manual thoroughly before installing, operating, or maintaining this lift.
2. This lift is designed for indoor use only, and should not be installed in a pit or depression.
3. The floor on which the lift is to be installed must be 6-inch minimum thickness concrete, with a minimum compressive strength of 3000 PSI, and reinforced with steel bar.
4. The lifts have specific electrical requirements as described in the Installation Instructions section of this manual.
5. This lift has a minimum ceiling height requirement as described in the Installation Instructions section of this manual.
6. Failure by the owner to provide the recommended shelter, mounting surface, electrical supply, and ceiling height could result in unsatisfactory lift performance, property damage, or personal injury.
7. Do not attempt to install this lift if you have never been trained on basic automotive lift installation procedures. Reference ANSI/ALI ALIOM Safety requirements for Installation and Service of Automotive Lifts.
8. Never attempt to lift components without proper lifting tools such as forklift or cranes. Stay clear of any moving parts that can fall and cause injury. These instructions must be followed to insure proper installation and operation of your lift. Failure to comply with these instructions can result in serious bodily harm and void product warranty.
9. Danmar Equipment will assume no liability for loss or damage of any kind, expressed or implied resulting from improper installation or use of this product.

DEFINITIONS OF HAZARD LEVELS

Identify the hazard levels used in this manual with the following definitions and signal words: Watch for this symbol: Alerts immediate hazards which will result in severe personal injury or death.



Watch for this symbol: Alerts hazards or unsafe practices which could result in severe personal injury or death.



Watch for this symbol: Alerts hazards or unsafe practices which may result in minor personal injury, product or property damage.



Lubricate all cable sheaves, bearings, and shafts with white lithium grease prior to operating the lift. Lubricate all on an annual basis.

Motors and all electrical components are not sealed against the weather and moisture. Install this lift in a protected indoor location. Failure by the owner to provide the recommended shelter could result in unsatisfactory lift performance, property damage, or personal injury.

IMPORTANT SAFETY INSTRUCTIONS

READ THESE SAFETY INSTRUCTIONS ENTIRELY!

IMPORTANT NOTICE !

Do not attempt to install this lift if you have never been trained on basic automotive lift installation procedures. Never attempt to lift components without proper lifting tools such as forklift or cranes. Stay clear of any moving parts that can fall and cause injury.

1. **READ ALL INSTRUCTIONS.**
2. **READ AND UNDERSTAND** all safety warning procedures before operating lift.
3. **KEEP AREA WELL LIT.**
4. **WARNING! RISK OF EXPLOSION.** This equipment has internal arcing or sparking parts which should not be exposed to flammable vapors. This machine should not be located in a recessed area or below floor level.
5. **KEEP CONTROL HANDLES AND/OR BUTTONS** dry, clean and free from grease and oil.
6. **CARE MUST BE TAKEN** as burns can occur from touching hot parts.
7. **DO NOT** operate equipment with a damaged power cord or if the equipment has been dropped or damaged until it has been examined by a qualified service person.
8. **DO NOT** let the power cord come in contact with hot manifolds or moving fan blades.
9. **IF AN EXTENSION CORD IS NECESSARY**, a cord with a current rating equal to or more than that of the equipment should be used. Cords rated for less current than the equipment may overheat. Care should be taken to arrange the cord so that it will not be tripped over or pulled.
10. **ALWAYS UNPLUG EQUIPMENT FROM ELECTRICAL OUTLET WHEN NOT IN USE.** Never use the power cord to pull the power plug from the outlet. Grasp the plug and pull to disconnect.
11. **LET EQUIPMENT COOL COMPLETELY BEFORE PUTTING AWAY.** Loop power cord loosely around equipment when storing.
12. **TO REDUCE THE RISK OF FIRE**, do not operate equipment in the vicinity of open containers of flammable liquids (i.e., gasoline).
13. **ADEQUATE VENTILATION SHOULD BE PROVIDED** when working on operating internal combustion engines.
14. **KEEP HAIR, LOOSE CLOTHING, FINGERS, AND ALL PARTS OF THE BODY AWAY FROM MOVING PARTS.**
15. **TO REDUCE THE RISK OF ELECTRIC SHOCK**, do not use on wet surfaces or expose to rain.
16. **USE ONLY AS DESCRIBED IN THIS MANUAL.** Use only manufacturer's recommended attachments.
17. **DO NOT** raise vehicle on the lift until installation is completed as instructed in this manual.
18. **KEEP HANDS AND FEET CLEAR.** Remove hands and feet from any moving parts. Keep feet clear of lift when lowering. Avoid pinch points.
19. **KEEP WORK AREA CLEAN.** Cluttered work areas invite injuries.
20. **CONSIDER WORK AREA ENVIRONMENT.** Do not expose equipment to rain. **DO NOT** use in damp or

wet locations. Keep area well lit.

21. **ONLY TRAINED OPERATORS** should operate this lift. All non-trained personnel should be kept away from work area. Never let non-trained personnel come in contact with, or operate lift.
22. **USE LIFT CORRECTLY.** Use lift in the proper manner. Never use lifting adapters other than what is approved by the manufacturer.
23. **DO NOT** override self closing lift controls.
24. **REMAIN CLEAR** of lift when raising or lowering vehicle.
25. **CLEAR AREA** if vehicle is on danger of falling.
26. **ALWAYS ENSURE** that the safeties are engaged before any attempt is made to work on or near vehicle.
27. **DRESS PROPERLY.** Non-skid steel-toe footwear is recommended when operating lift.
28. **GUARD AGAINST ELECTRIC SHOCK.** This lift must be grounded while in use to protect the operator from electric shock. Never connect the green power cord wire to a live terminal. This is for ground only.
29. **DANGER!** The power unit used on this lift contains high voltage. Disconnect power at the receptacle before performing any electrical repairs. Secure plug so that it cannot be accidentally plugged in during service.
30. **ALWAYS WEAR SAFETY GLASSES.** Everyday eyeglasses only have impact resistant lenses. They are not safety glasses.
31. **MAINTAIN WITH CARE.** Keep lift clean for better and safe performance. Follow manual for proper lubrication and maintenance instructions. Keep control handles and/or buttons dry, clean and free from grease and oil.
32. **STAY ALERT.** Follow instructions carefully. Be aware of dangers. Double check your work.
33. **CHECK FOR DAMAGED PARTS.** Check for alignment of moving parts, breakage of parts or any condition that may affect its operation. Do not use lift if any component is broken or damaged.
34. **NEVER** remove safety related components from the lift. Do not use lift if safety related components are damaged or missing.
35. **NOTE:** If attachments, accessories, or configuration modifying components that are located in the load path, affect operation of the lift, affect the lift electrical listing or affect intended vehicle accommodation are used on this lift and, if they are not certified for use on this lift, then the certification of this lift shall become null and void. Contact Danmar Equipment for information pertaining to certified attachments, accessories, or configuration modifying components.

SAVE THESE INSTRUCTIONS

OWNER / EMPLOYER RESPONSIBILITIES

- Shall ensure that lift operators are qualified and that they are trained in the safe use and operation of the lift using the manufacturer's operating instructions; ALI/SM01-1, ALI Lifting it Right safety manual; ALI/ST-10 ALI Safety Tips card; ANSI/ALI ALOIM-2008, American National Standard for Automotive Lifts Safety Requirements for Operation, Inspection and Maintenance; ALI/WL Series, ALI Uniform Warning Label Decals/Placards; and in the case of frame engaging lifts, ALI/LP-GUIDE, Vehicle Lifting Points/Quick Reference Guide for Frame Engaging Lifts.
- Shall establish procedures to periodically inspect the lift in accordance with the lift manufacturer's instructions or ANSI/ALI ALOIM-2008, American National Standard for Automotive Lifts Safety Requirements for Operation, Inspection and Maintenance; and The Employer Shall ensure that lift inspectors are qualified and that they are adequately trained in the inspection of the lift.
- Shall establish procedures to periodically maintain the lift in accordance with the lift manufacturer's instructions or ANSI/ALI ALOIM-2008, American National Standard for Automotive Lifts Safety Requirements for Operation, Inspection and Maintenance; and The Employer Shall ensure that lift maintenance personnel are qualified and that they are adequately trained in the maintenance of the lift.
- Shall maintain the periodic inspection and maintenance records recommended by the manufacturer or ANSI/ALI ALOIM-2008, American National Standard for Automotive Lifts Safety Requirements for Operation, Inspection and Maintenance.
- Shall display the lift manufacturer's operating instructions; ALI/SM 93-1, ALI Lifting it Right safety manual; ALI/ST-90 ALI Safety Tips card; ANSI/ALI ALOIM-2008, American National Standard for Automotive Lifts Safety Requirements for Operation, Inspection and Maintenance; and in the case of frame engaging lifts, ALI/LP-GUIDE, Vehicle Lifting Points/Quick Reference Guide for Frame Engaging Lifts; in a conspicuous location in the lift area convenient to the operator.
- Shall not modify the lift in any manner without the prior written consent of the manufacturer.
- Shall provide necessary lockout/tagout means for energy sources per ANSI Z244.1-1982 (R1993), safety requirements for the lockout/tagout of energy sources, before beginning any lift repairs.

INSTALLER / OPERATOR PLEASE READ AND FULLY UNDERSTAND. BY PROCEEDING YOU AGREE TO THE FOLLOWING.

- I have visually inspected the site where the lift is to be installed and verified the concrete to be in good condition and free of cracks or other defects. I understand that installing a lift on cracked or defective concrete could cause lift failure resulting in personal injury or death.
- I understand that a level floor is required for proper installation and level lifting.
- I understand that I am responsible if my floor is of questionable slope and that I will be responsible for all charges related to pouring a new level concrete slab if required and any charges.
- I understand that Dannmar lifts are supplied with concrete fasteners meeting the criteria of the American National Standard "Automotive Lifts Safety Requirements for Construction, Testing, and Validation" ANSI/ALI
- ALCTV-2011, and that I will be responsible for all charges related to any special regional structural and/or seismic anchoring requirements specified by any other agencies and/or codes such as the Uniform Building Code (UBC) and/or International Building Code (IBC).

- I will assume full responsibility for the concrete floor and condition thereof, now or later, where the above equipment model(s) are to be installed. Failure to follow danger, warning, and caution instructions may lead to serious personal injury or death to operator or bystander or damage to property.
- I understand that Danmar lifts are designed to be installed in indoor locations only. Failure to follow installation instructions may lead to serious personal injury or death to operator or bystander or damage to property or lift.

INSTALLER / OPERATOR PROTECTIVE EQUIPMENT

Personal protective equipment helps makes installation and operation safer, however, it does not take the place of safe operating practices. Always wear durable work clothing during any installation and / or service activity. Shop aprons or shop coats may also be worn, however loose fitting clothing should be avoided. Tight fitting leather gloves are recommended to protect technician hands when handling parts. Sturdy leather work shoes with steel toes and oil resistant soles should be used by all service personnel to help prevent injury during typical installation and operation activities. Eye protection is essential during installation and operation activities. Safety glasses with side shields, goggles, or face shields are acceptable. Back belts provide support during lifting activities and are also helpful in providing worker protection. Consideration should also be given to the use of hearing protection if service activity is performed in an enclosed area, or if noise levels are high.



D-9/X PARTS LIST

ITEM #	DESCRIPTION	QTY.
1	POWER SIDE POST ASSEMBLY	1
2	Ø 2.5 x 37 CYLINDER ASSEMBLY	2
3	MALE 90 ELBOW 2501-04-06	2
4	CABLE PULLEY ASSEMBLY	6
5	M20 FLAT WASHER	6
6	HAIRPIN COTTER	6
7	CHAIN ROLLER ASSEMBLY	2
8	CARRIAGE ASSEMBLY / CHAIN BREAK	2
9	TOP PLATE ASSEMBLY	2
10	M10 x 40 HEX HEAD BOLT	4
11	M10 LOCK WASHER	4
12	M10 x 1.5 HEX NUT	4
13	OFF SIDE POST ASSEMBLY	1
14	COVER PLATE	1
15	HYDRAULIC POWER UNIT	1
16	STRAIGHT THREAD 90 ELBOW W/ O-RING SEAL 6801-04-06-NWO	1
17	M8 x 25 HEX HEAD BOLT	4
18	M8 NYLON LOCK NUT	4
19	MEDIUM ARM ASSEMBLY	4
20	SLIP ON LIFT PAD ASSEMBLY	4
21	ARM PIN ASSEMBLY	4
22	TRUARC 5103-150 E-RING	4
23	SHORT LIFT PAD EXTENSION	4
24	LONG LIFT PAD EXTENSION	4
25	UNION TEE 2603-04-04-04	1
26	BL646 CHAIN CONNECTOR	2
27	BL646 CYLINDER CHAIN 1276mm LG	1
28	M18 NYLON LOCK NUT	4
29	EQUALIZER CABLE ASSEMBLY 9093mm LG	2
30	POWER UNIT HOSE ASSEMBLY 2921mm LG	4
31	HYDRAULIC HOSE ASSEMBLY 1676mm LG	2

D-9/X ASSEMBLY DIAGRAM

*Diagram shown with square lift pads. New models come standard with round lift pads. Please note: All Danmar lifts now come standard with round lift pads for greater durability. Call for more information.

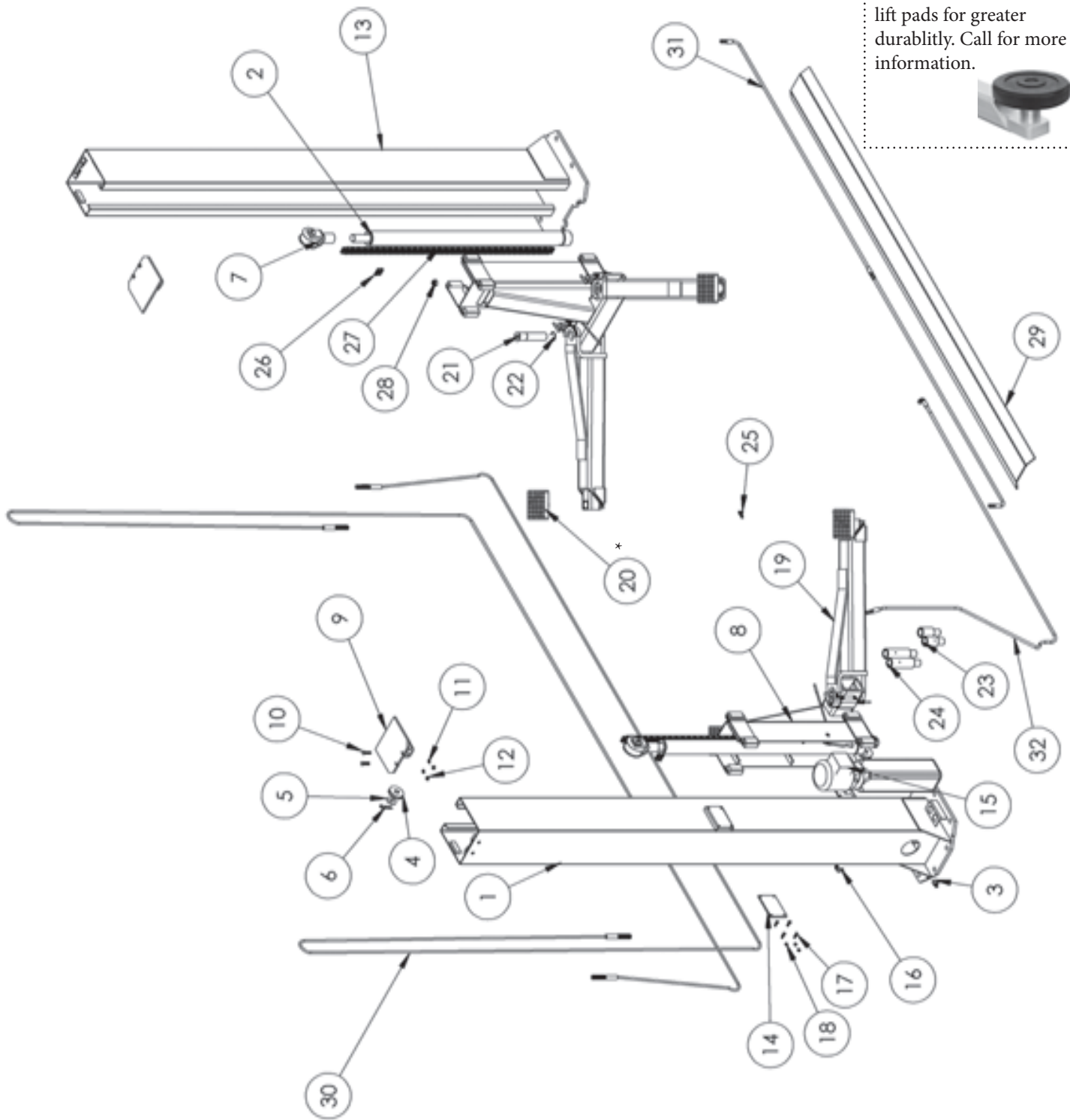

INSTALLATION INSTRUCTIONS

TOOLS REQUIRED

- | | |
|--|---|
| <input type="checkbox"/> Rotary Hammer Drill Or Similar (If Anchoring) | <input type="checkbox"/> Large Crescent Wrench |
| <input type="checkbox"/> 3/4" Masonry Bit (If Anchoring) | <input type="checkbox"/> Large Pipe Wrench |
| <input type="checkbox"/> Hammer | <input type="checkbox"/> Crow Bar |
| <input type="checkbox"/> 4 Foot Level | <input type="checkbox"/> Chalk Line |
| <input type="checkbox"/> Open End Wrench Set: Metric | <input type="checkbox"/> Medium Flat Screwdriver |
| <input type="checkbox"/> Socket And Ratchet Set: Metric | <input type="checkbox"/> Tape Measure : 25 Foot Minimum |
| <input type="checkbox"/> Hex Key / Metric Allen Wrench Set | <input type="checkbox"/> Needle Nose Pliers |

IMPORTANT NOTICE!

These instructions must be followed to ensure proper installation and operation of your lift. Failure to comply with these instructions can result in serious bodily harm and void product warranty. Manufacturer will assume no liability for loss or damage of any kind, expressed or implied resulting from improper installation or use of this product.

STEP 1 (Selecting Site)

BEFORE INSTALLING YOUR NEW LIFT, CHECK THE FOLLOWING:

1. **LIFT LOCATION:** Always use architects plans when available. Check layout dimension against floor plan requirements making sure that adequate space is available.
2. **OVERHEAD OBSTRUCTIONS:** The area where the lift will be located should be free of overhead obstructions such as heaters, building supports, electrical lines etc.
3. **DEFECTIVE FLOOR:** Visually inspect the site where the lift is to be installed and check for cracked or defective concrete.
4. **OPERATING TEMPERATURE.** Operate lift only between temperatures of 41° -104° F.
5. Lift is designed for **INDOOR INSTALLATION ONLY.**

STEP 2 (Floor Requirements)

This lift must be installed on a solid level concrete floor with no more than 3-degrees of slope. Failure to do so could cause personal injury or death.



DO NOT install this lift on any asphalt surface or any surface other than concrete.

DO NOT install this lift on expansion seams or on cracked or defective concrete.

DO NOT install this lift on a second / elevated floor without first consulting building architect.

DO NOT install this lift outdoors.

CONCRETE SPECIFICATIONS

9,000-lb 2-Post Lift Models Require 6" Min. Thickness / 3,000 PSI - Steel Reinforced.

IMPORTANT NOTE:

All models **MUST** be installed on 3000 psi concrete only conforming to the minimum requirements shown above. New concrete must be adequately cured by at least 28 days minimum. Danmar lifts are supplied with installation instructions and concrete fasteners meeting the criteria as prescribed by the American National Standard "Automotive Lifts Safety Requirements for Construction, Testing, and Validation" ANSI/ALI ALCTV-2011. Lift buyers are responsible for any special regional structural and / or seismic anchoring requirements specified by any other agencies and / or codes such as the uniform building code (ubc) and / or international building code (ibc).

STEP 3 (Site Layout)

1. Determine which side will be the approach side.
2. Now determine where the Power Unit will be located. The POWERSIDE column has the power unit mounting bracket attached to the side.
3. Once a location is determined, use a carpenters chalk line to layout a grid for the Post locations. Keep all dimensions and squareness within 1/8" or malfunctioning of the lift can occur.
4. After the Post locations are properly marked, use a chalk or crayon to make an outline of the Posts on the floor at each location using the Post Base Plates as a template.
5. Double check all dimensions and make sure that the layout is perfectly square.

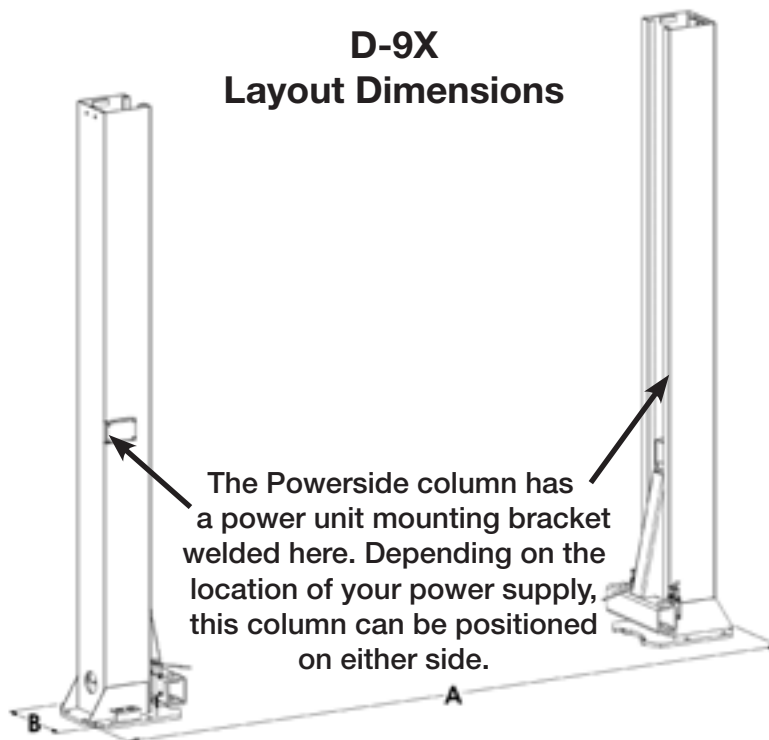

MODEL	A	B	RECOMMENDED BAY DIMENSIONS
D-9/X	145"	17"	16' wide x 24' deep 12'6" tall

STEP 4 (Install Powerside Column)

1. Before proceeding, double check measurements and make certain that the bases of each column are square and aligned with the chalk line.
2. Using the base plate on the column as a guide, drill each anchor hole in the concrete approximately 7" deep using a rotary hammer drill and 3/4" concrete drill. To assure full holding power, do not ream the hole or allow drill to wobble. (See figure 1)
3. After drilling, remove dust thoroughly from each hole using compressed air and/or wire brush. Make certain that the column remains aligned with the chalk line during this process.
4. Assemble the washers and nuts on the anchors then tap into each hole with a hammer until the washer rests against the base plate. Be sure that if shimming is required that enough threads are left exposed. (See figure 2)
5. If shimming is required, insert the shims as necessary under the base plate so that when the anchor bolts are tightened, the columns will be plumb. (See figure 3)
6. With the shims and anchor bolts in place, tighten by securing the nut to the base then turning 2-3 full turns clockwise. DO NOT use an impact wrench for this procedure.

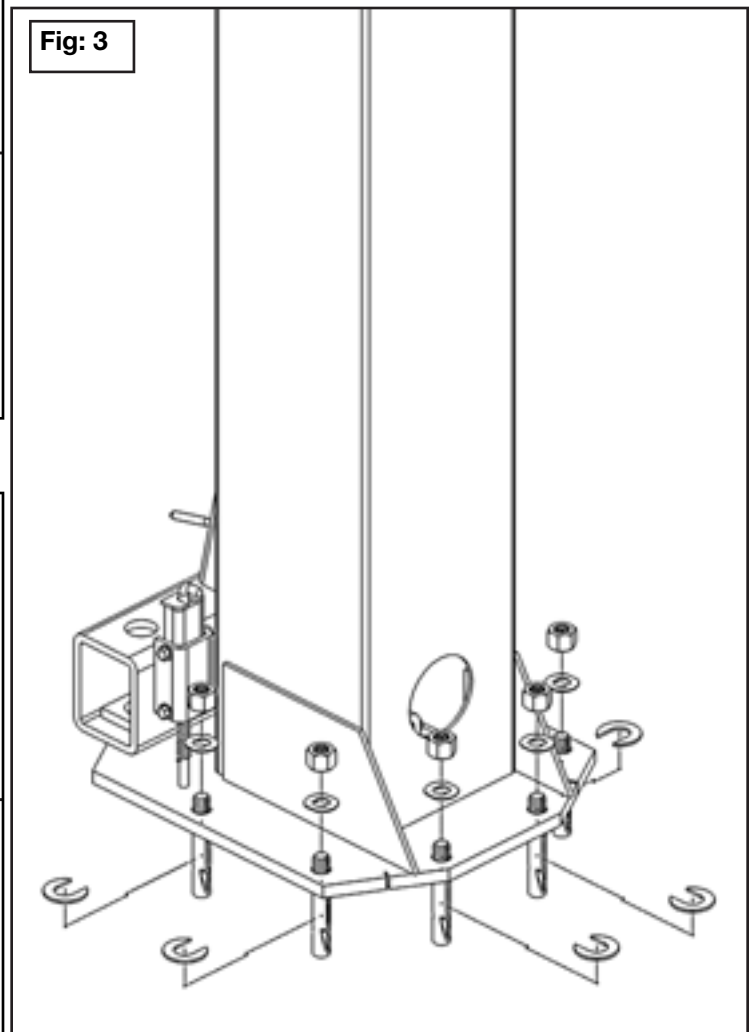
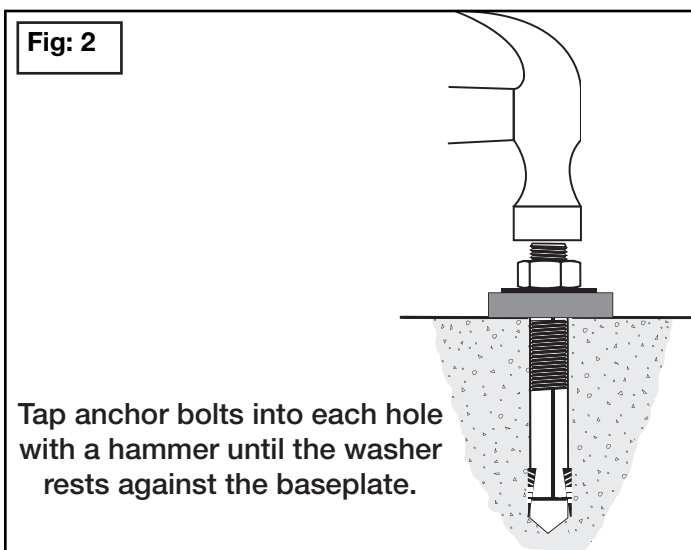
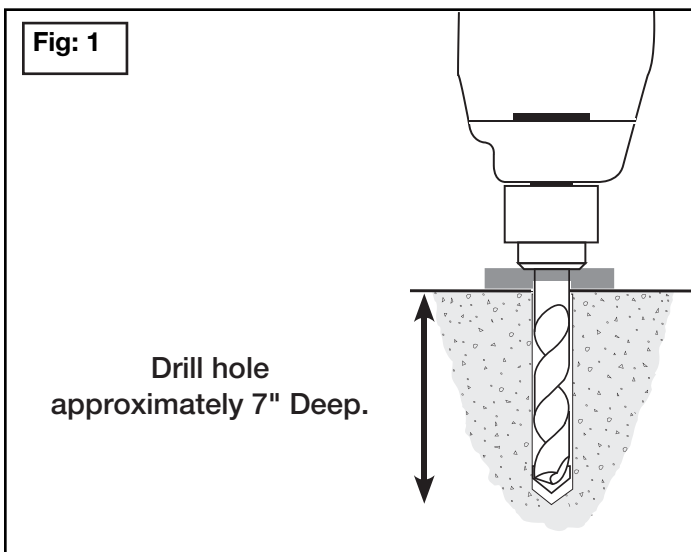

STEP 5 (Install Offside Column)

1. Position the OFFSIDE column at the designated chalk locations and secure to the floor following the same procedures as outlined in STEP 4.

STEP 6 (Mounting the Top Pulley Assembly)

1. Position the top pulley plate on top of the columns. Bolt to the columns using the M10 x 40mm Hex Bolts, Nuts and Washers. (See figure 6)

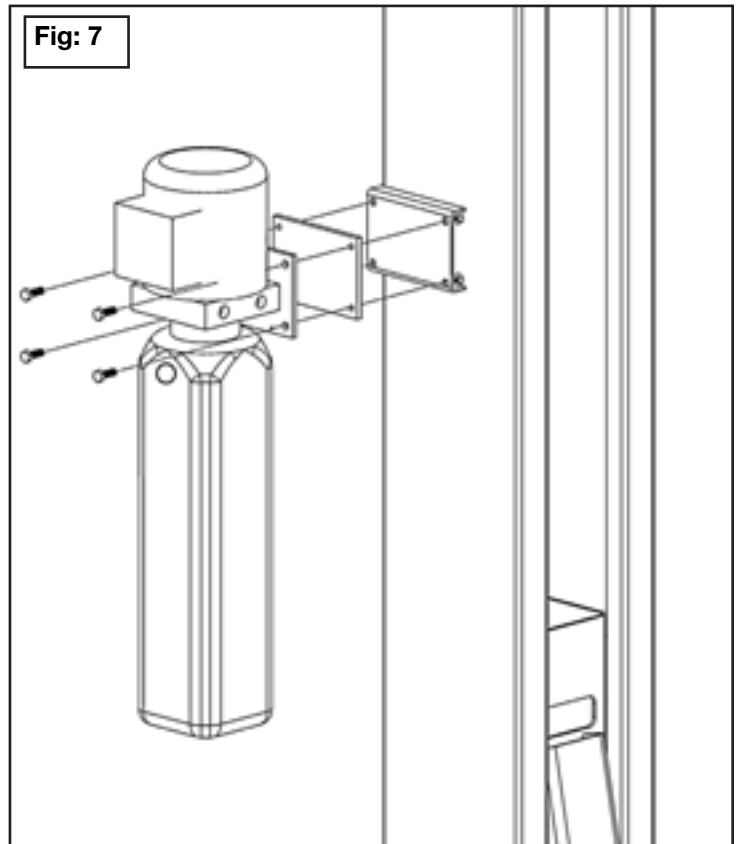
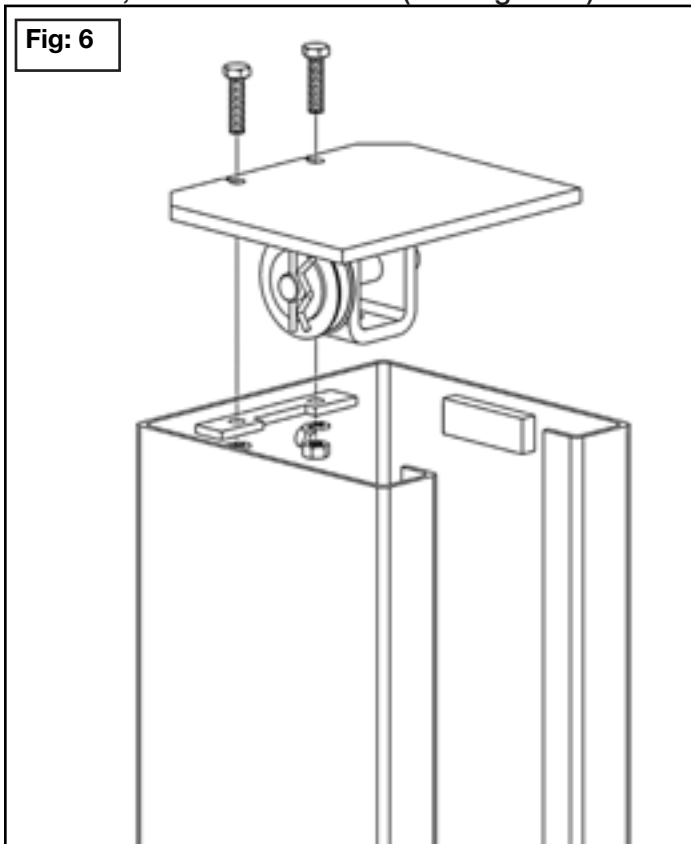

STEP 7 (Mounting the Power Unit)

1. Attach the power unit and vibration pad to the powerside column using four M8 x 25mm hex bolts and nylon lock nuts supplied (See Fig. 7). Fill the reservoir with 12 quarts Aw-32 hydraulic oil or Dexron III or VI transmission fluid . Be sure to use a clean funnel.

STEP 8 (Installing Equalizer Cables)

1. Raise and lock each carriage approximately 28" above the ground.



2. Make sure that the safety locks on each column are fully engaged before attempting to route equalizer cables. Carriages must be equal height from the floor before proceeding. Failure to assure lifting carriage is on the lock may result in rapid drop causing severe injury.

3. With the carriages in equal position from the floor, start by feeding the cable thru the right side hole (when looking into the post on the open side) in the top of the carriage down thru the bottom of the carriage around the bottom pulley (right side), across the floor around the bottom pulley on the opposite Post (left side), thru the back of the carriage to the top Pulley and connect to the left side hole in the top of the carriage. Repeat steps on cable # 2. (See figure 8)
4. After the equalizer cables have been routed, adjust each cable so that they are equal tension. (Guitar String Tight) Helpful Hint: You can remove the top pulley to get slack in the cable facing down and push it through the bottom of the carriage and get better access to tighten the cable nut, push the cable pulley back on and make final adjustment.

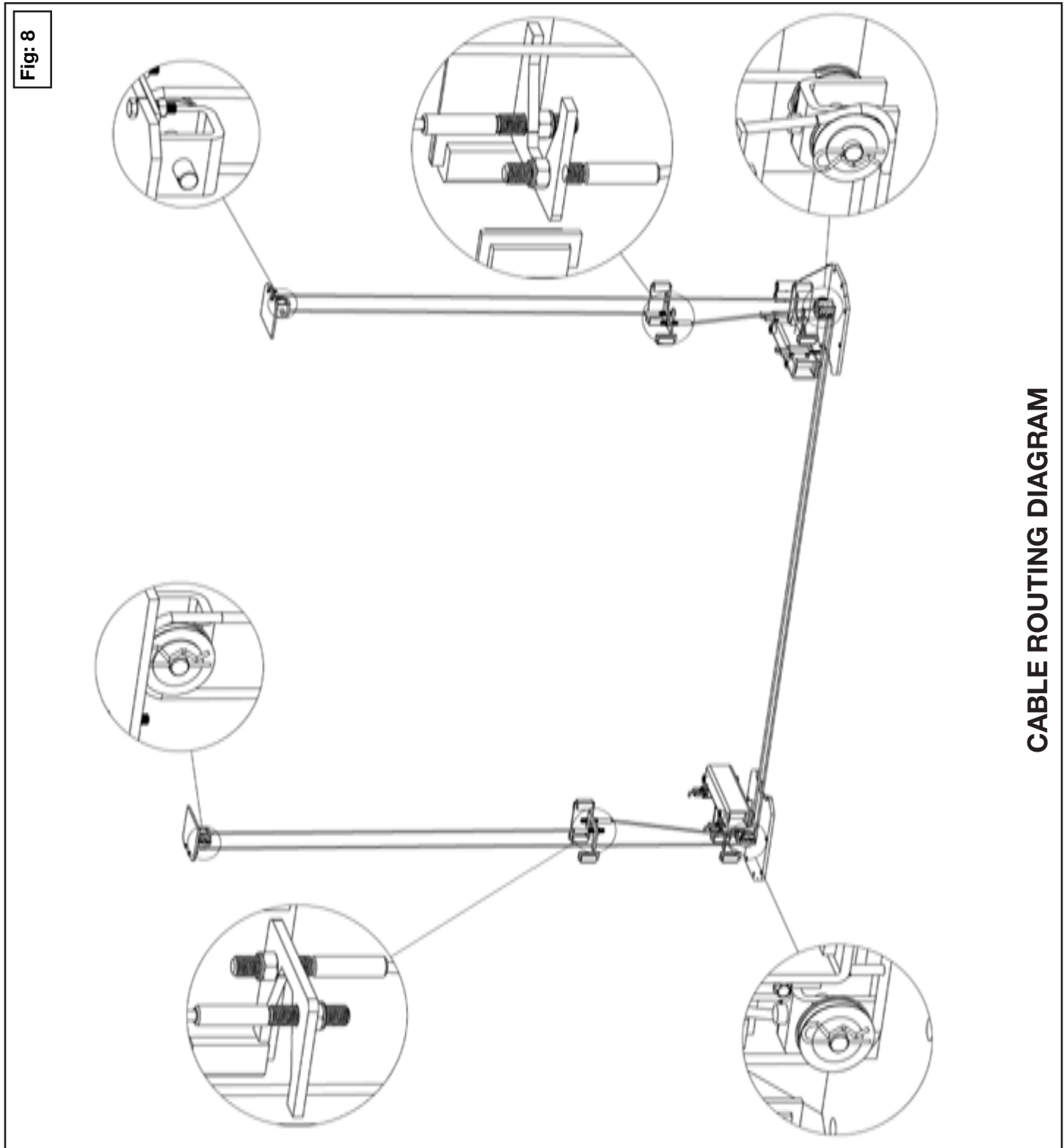

STEP 9 (Installing Hydraulic Lines)

1. Connect the straight side of the long hose to the power unit pressure port with a red plastic plug using the 90 degree o-ring power unit fitting. Route the opposite side of the hose (90-degree side) through the cylinder access hole in the back of the post, under the cylinder cradle and out to the middle of the cover plate. (See figure 9)
2. Route the 2 short hoses from each cylinder to the center of the lift and connect them to the cylinder using the 90 degree fittings provided. (See figure 9)
3. Connect all three hoses to the union tee provided under the middle of the cover plate and be sure the hoses are routed in the middle of the cable path and tie off as needed to avoid any contact between the hose and cable.

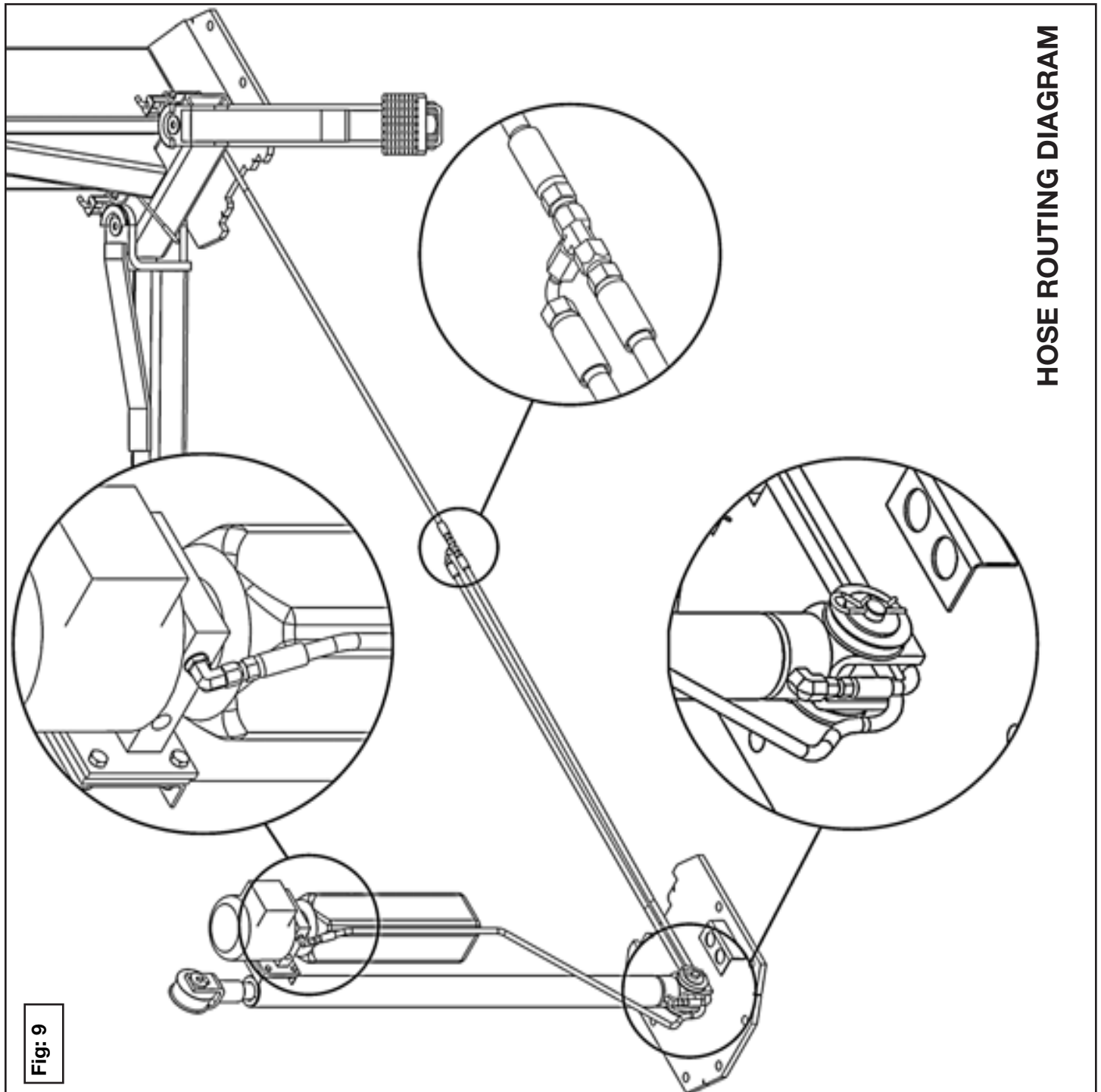

STEP 7 (Wiring the Power Unit)

1. The standard power unit for your lift is 220 volt, 60HZ, single phase. **ALL WIRING MUST BE PERFORMED BY A CERTIFIED ELECTRICIAN ONLY.**
2. **SEE WIRING INSTRUCTIONS AFFIXED TO MOTOR FOR PROPER WIRING INSTRUCTIONS.**

IMPORTANT INSTALLATION NOTES



- **DO NOT PERFORM ANY MAINTENANCE OR INSTALLATION OF ANY COMPONENTS WITH OUT FIRST ENSURING THAT ELECTRICAL POWER HAS BEEN DISCONNECTED AT THE SOURCE OR PANEL AND CANNOT BE RE ENERGIZED UNTIL ALL MAINTENANCE AND / OR INSTALLATION PROCEDURES ARE COMPLETED.**
- **NEVER** operate the motor on line voltage less than 208V. Motor damage may occur which is not covered under warranty.
- **DO NOT** run power unit with no oil. Damage to pump can occur.
- The power unit must be kept dry. Damage to power unit caused by water or other liquids such as detergents, acid etc., are not covered under warranty.
- Improper electrical hookup can damage the motor and will not be covered under warranty.
- Motor can not run on 50HZ without a physical change in the motor.
- Use a separate breaker for each power unit.
- Protect each circuit with a time delay fuse or circuit breaker.
- For 208 -230 volt, single phase, use a 20 amp fuse.
- For 208-230 volt, three phase, use a 30 amp fuse.
- For 460 volt, three phase, use a 30 amp fuse.



- **DO NOT** attempt to raise vehicle until a thorough operation check has been completed.

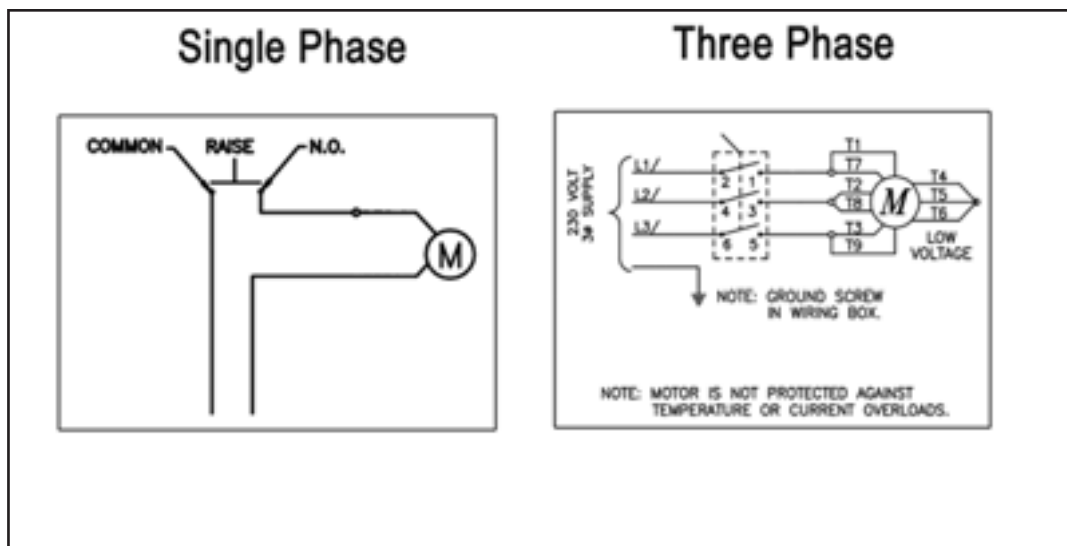

STEP 14 (Installing the Lift Arms)

1. Place the lift arm assembly in the lift heads. (See figure 10)
2. Install the lift head pins into the lift head and through the holes in the arm assembly. (See figure 11)
3. Install the snap ring into the groove on the lift head pin in the middle of the lift head tube. (See figure 11)
4. Loosen the arm lock assembly bolts and adjust so that the teeth on the gear mesh smoothly with the teeth on the arm gears. (See figure 12)
5. Tighten the arm lock assembly bolts.
6. Verify the operation of the arm lock assembly by pulling up on the handle of the arm lock assembly. Pivot the arms back and forth and test the operation of the arm lock assembly in various positions. When releasing the arm lock assembly the pin should drop and the gears should engage.
7. Ensure that the arms do not move when a force of approximately 100-pounds or less is applied laterally to the fully extended arms.
8. Adjust the arm lock assembly as necessary to ensure smooth operation and solid engagement of all four arm lock assemblies with the arm gears.

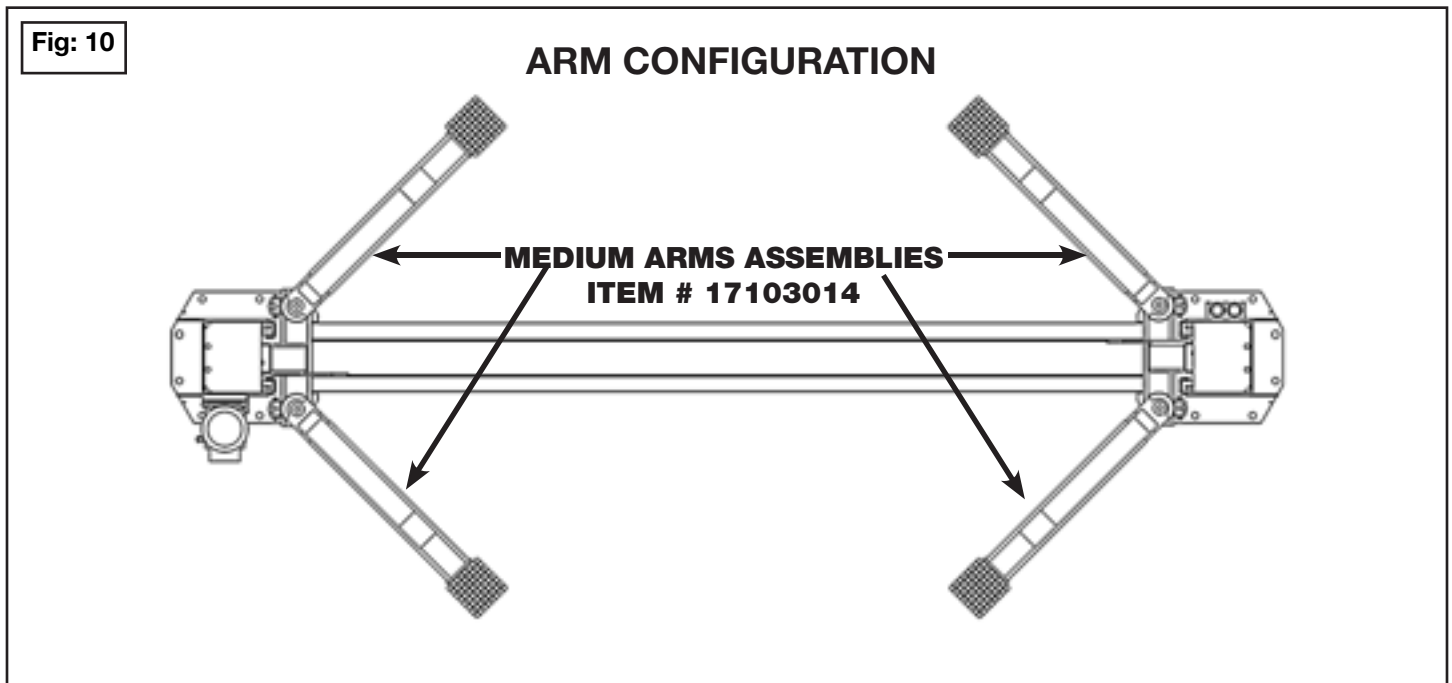

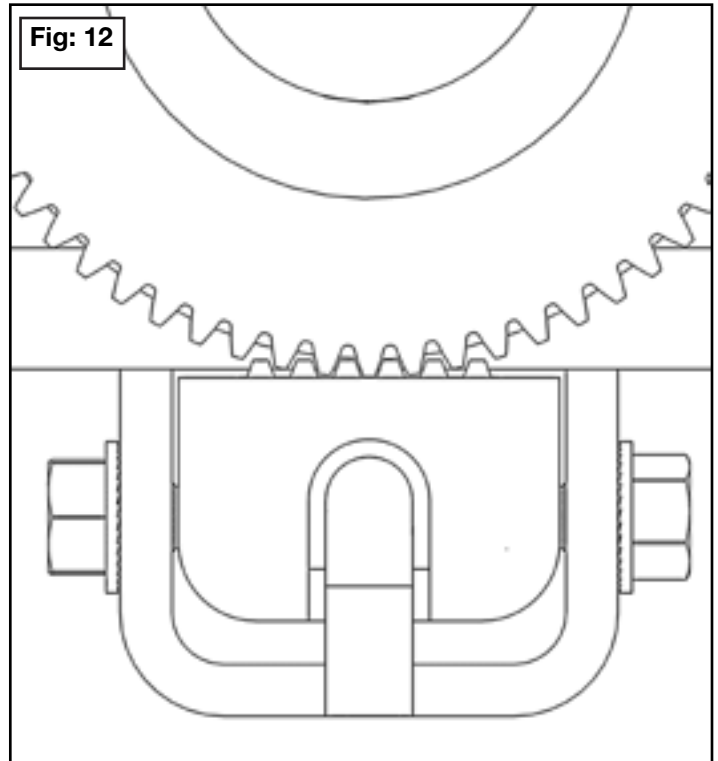
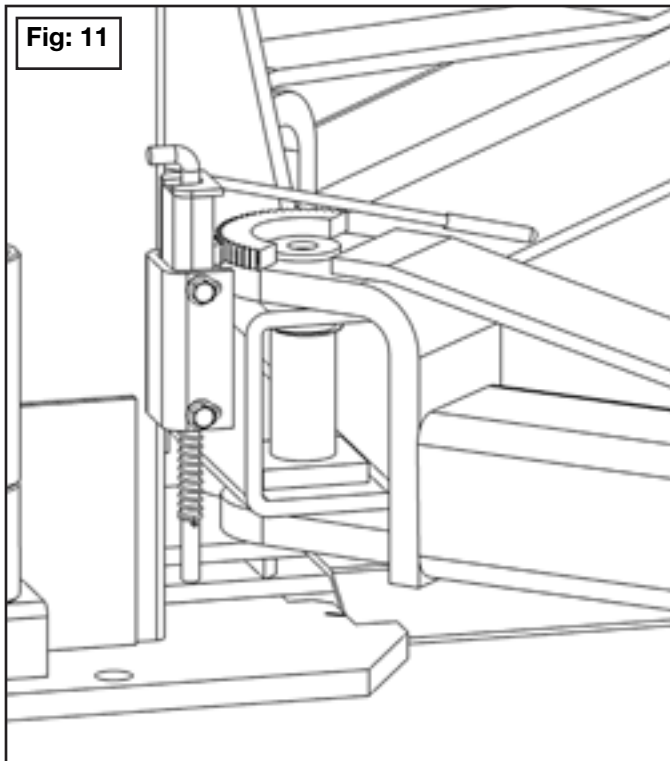

! DANGER

EACH ARM RESTRAINT ASSEMBLY MUST BE INSPECTED AND ADJUSTED AS NEEDED BEFORE EACH AND EVERY TIME THE LIFT IS OPERATED. DO NOT OPERATE THE LIFT IF ANY OF THE FOUR ARM RESTRAINT SYSTEMS ARE NOT FUNCTIONING PROPERLY. REPLACE ANY BROKEN COMPONENTS OR COMPONENTS WITH BROKEN TEETH ONLY WITH AUTHORIZED OR APPROVED REPLACEMENT PARTS.

STEP 15 (Leveling Instructions)

1. Before operating your lift, check to make sure that both "A" and "B" measurements are equal.
(See figure 13)
2. Lift arms must be level before operation, if your lift arms are not level shim the columns as required.
(See figure 3 on page 12)

IMPORTANT NOTE:

The equalizer cables should be checked weekly for equal tension. Failure to do this will cause uneven lifting. The cables should always be adjusted so that they are equal tension when resting on the safety locks.

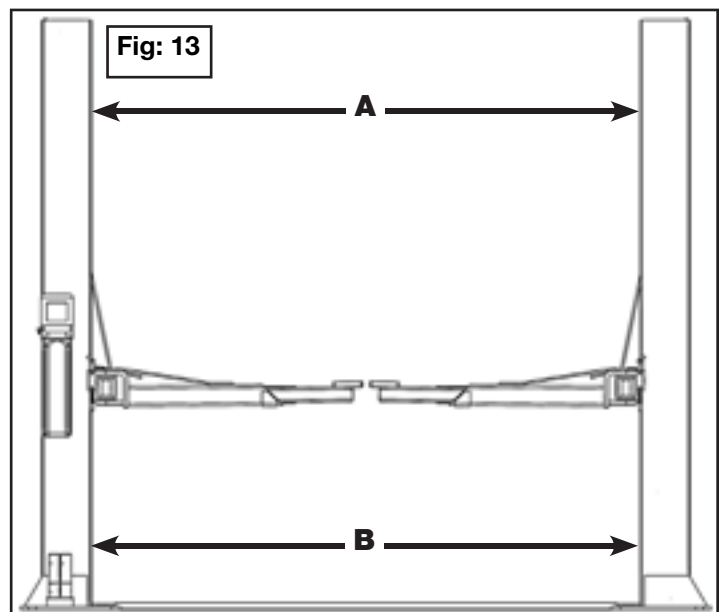

STEP 16 (Start Up)



RISK OF EXPLOSION!

This equipment has internal arcing or parts that may spark and should not be exposed to flammable vapors. Motor should not be located in a recessed area or below floor level. NEVER expose motor to rain or other damp environments. **DAMAGE TO MOTOR CAUSED BY WATER IS NOT COVERED UNDER WARRANTY.**



During the **START UP** procedure, observe all operating components and check for proper installation and adjustment. **DO NOT** attempt to raise vehicle until a thorough operational check has been completed.

1. Make sure the power unit reservoir is full with 12 quarts AW-32 hydraulic oil or Dexron III or VI automatic transmission fluid.
2. Spray the inside of the columns where the slide blocks glide with white lithium grease.
3. Test the power unit by pressing the push button switch. If the motor sounds like it is operating properly, raise the lift and check all hose connections for leaks. If the motor gets hot or sounds peculiar, stop and check all electrical connections.
4. Before proceeding, double check to make sure all cables are properly positioned within the grooves of all sheaves. Make sure all cable sheave retaining pins and / or clips are secure.
5. Check to make sure that all safety locks are cleared and free.
6. Continue pressing the raise button until the cables get tight and the lift starts to move.
7. **KEEP HANDS AND FEET CLEAR.** Remove hands and feet from any moving parts. Keep feet clear of lift when lowering. Avoid pinch points.
8. Check all main safety locks to make sure they move freely and spring back to the lock position when released. Lubricate all safety pivot points with a white lithium grease.
9. Run the lift up and down a few times to ensure that the safety locks are engaging uniformly and that the safety release mechanisms are functioning. Re-adjust if necessary.

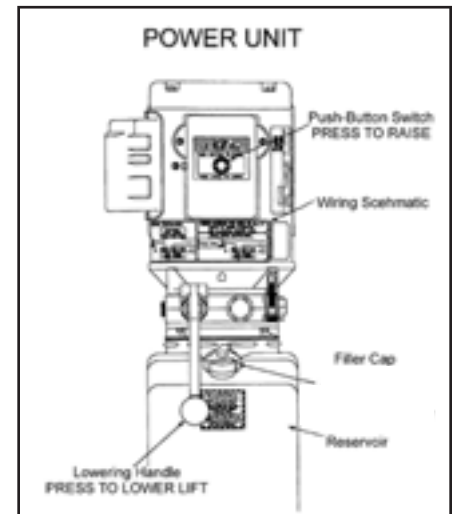

IMPORTANT NOTE:

There will be initial stretching of the cables with increased loads. The equalizer cables should be checked weekly for equal tension. Failure to do this will cause uneven lifting. The cables should always be adjusted so that they are equal tension when resting on the safety locks.

POST INSTALLATION CHECK OFF

- Columns are properly shimmed and stable
- Anchor bolts are tightened
- Pivot / sheave pins are properly attached
- Electric power supply confirmed
- Cables are adjusted properly
- Safety locks are functioning properly
- Check for hydraulic leaks
- Oil level
- Lubcation of critical components
- Check for overhead obstructions
- Lift arms are level
- All screws, bolts, and pins are secured
- Surroung area is clean
- Operation, maintenance and safety manuals on site.

LUBRICATION POINTS

1. After installation and start up has been completed, lubricate the lift components described below on both columns with white lithium grease. (See figure 14)

- A. All 4 sides of Column where slide blocks make contact.
- B. All 4 Arm Pivot Pins.
- C. All 6 Cable Pulleys.

STEP 17 OPERATION INSTRUCTIONS

LIFT OPERATION SAFETY

- **DAILY** inspect your lift. Never operate if it malfunctions or if it has broken or damaged parts. Use only qualified lift service personnel and genuine Danmar parts to make repairs.
- **THOROUGHLY** train all employees in use and care of lift, using manufacturer's instructions and "Lifting It Right" and "Safety Tips" supplied with the lift.
- **NEVER** allow unauthorized or untrained persons to position vehicle or operate lift.
- **PROHIBIT** unauthorized persons from being in shop area while lift is in use.
- **DO NOT** permit anyone on lift or inside vehicle when it is either being raised or lowered.
- **ALWAYS** keep area around lift free of tools, debris, grease and oil.
- **NEVER** overload lift. Capacity of lift is shown on nameplate affixed to the lift.

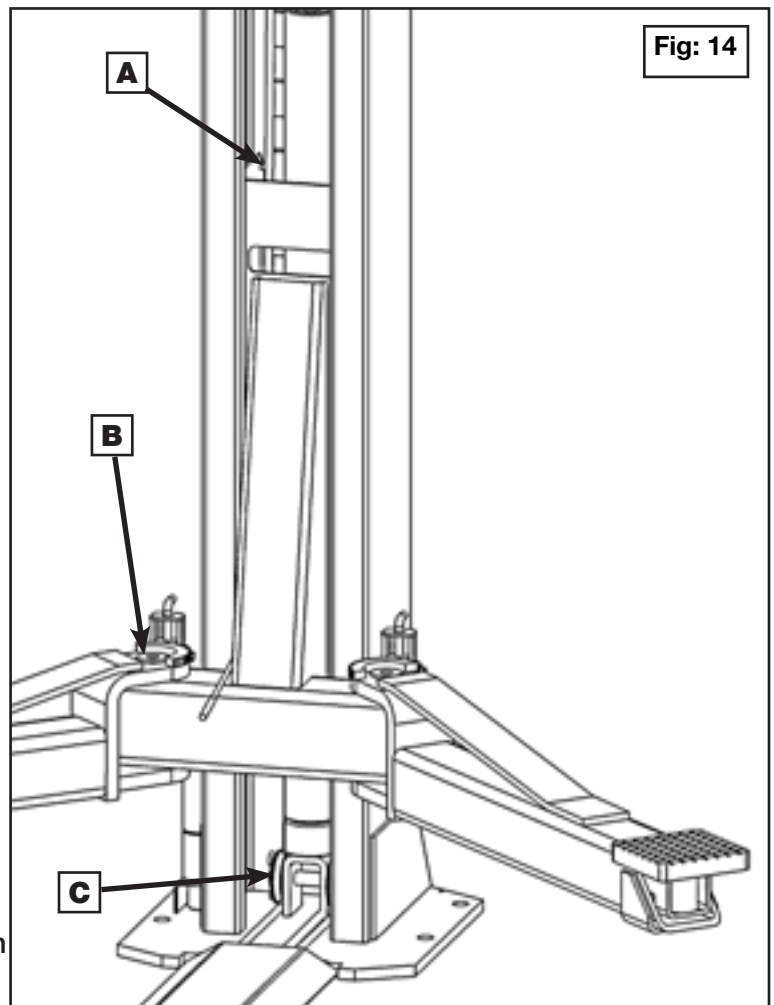

- **DO NOT** stand in front of the vehicle while it is being positioned in lift bay.
- **DO NOT** hit or run over lift arms or adapters. This could damage lift or vehicle. Before driving vehicle into lift bay, position arms and adapters to provide unobstructed entrance to lift.
- **ALWAYS** load vehicle on lift carefully. Position the lift adapters to contact at the vehicle manufacturer's recommended lift points. Raise lift until adapters contact vehicle. Check adapters for secure contact with vehicle. Raise lift to desired working height. (See figure 15)
- **DO NOT** block open or override self closing lift controls; they are designed to return to the "Off" or Neutral position when released.
- **DO NOT** remove or disable arm restraints.
- **ALWAYS** remain clear of lift when raising or lowering vehicles.
- **ALWAYS** use safety stands when removing or installing heavy components.
- **DO NOT** go under raised vehicle if safety locks are not engaged.

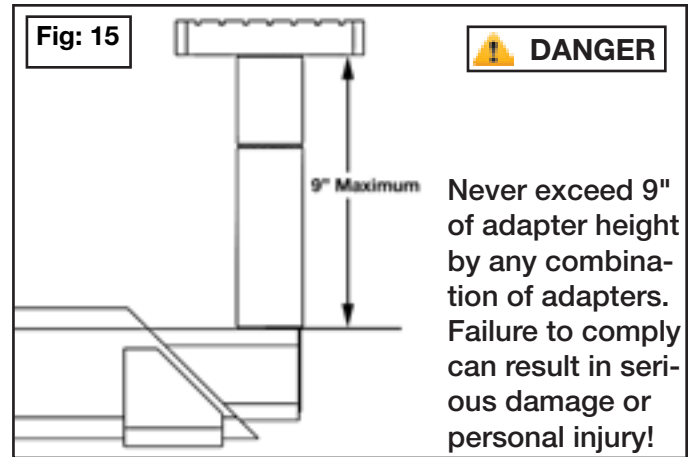

DANGER

VISUALLY CONFIRM THAT ALL PRIMARY SAFETY LOCKS ARE ENGAGED BEFORE ENTERING WORK AREA.

- Hydraulic components that are used on this lift are intended to raise and lower the lift only and are not meant to be a load holding device. Remain clear of the elevated lift unless visual confirmation is made that all primary safety locks are fully engaged and the lift is **LOWERED** onto the safety locks, Refer to installation /operation manual for proper safety lock procedures and /or further instruction.
- **NEVER LEAVE LIFT IN ELEVATED CONDITION** unless all Safety Locks are engaged.
- **AVOID** excessive rocking of vehicle while on lift.
- **ALWAYS CLEAR AREA** if vehicle is in danger of falling.

DANGER

When lowering the lift **PAY CAREFUL ATTENTION** that all personnel and objects are kept clear. **ALWAYS** keep a visual line of site on the lift **AT ALL TIMES**. **ALWAYS** make sure that **ALL LOCKS** are disengaged. If one of the locks inadvertently locks on descent the lift and/or vehicle may disrupt causing personal injury or death.

- **ALWAYS REMOVE** tool trays, stands, etc. before lowering lift.
- **ALWAYS RELEASE** safety locks before attempting to lower lift.
- **ALWAYS POSITION** the lift arms and adapters to provide an unobstructed exit before removing vehicle from lift area.

TO RAISE THE LIFT



WARNING

To avoid personal injury and / or property damage, permit only trained personnel to operate lift. After reviewing these instructions, get familiar with lift controls by running the lift through a few cycles before loading vehicle on lift. Always lift the vehicle using all four adapters. **NEVER** raise just one end, one corner, or one side of vehicle.

1. Before Loading: Lift must be fully lowered and service bay clear of all personnel before the vehicle is brought on lift with the swing arms set to the full drive thru position.
2. Loading: Swing arms under vehicle and position adapters at vehicle manufacturer's recommended lift points. Use height extenders or optional frame cradle adapters when necessary to ensure good contact. (See figure 16)
3. Some vehicles may have the manufacturer's Service Garage Lift Point locations identified by triangle shape marks on the undercarriage (reference ANSI/SAE J2184-1992). Also, there may be a label located on the right front door jamb area showing specific vehicle lift points.

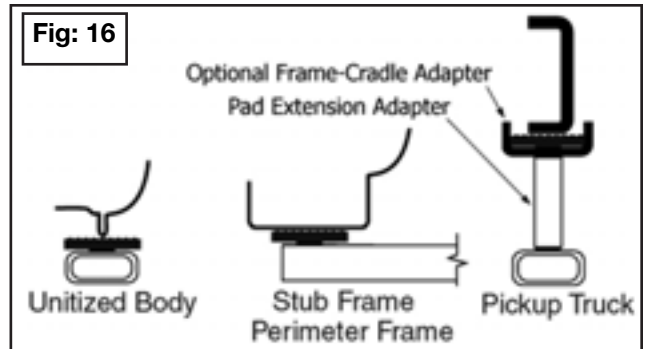

WARNING

Many specialty or modified vehicles cannot be raised on a two post frame engaging lift. Contact vehicle manufacturer for raising or jacking details.

4. Position vehicle for proper weight distribution arms under vehicle to allow adapters to contact at the manufacturer's recommended pick up points.

TYPICAL LIFTING POINTS

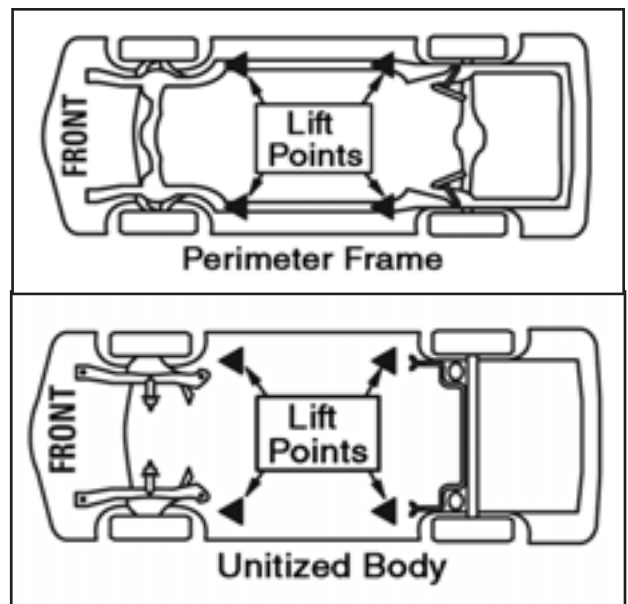
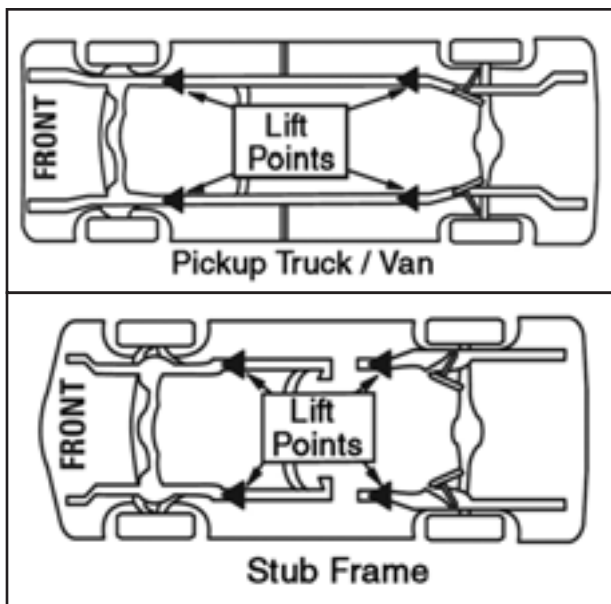

5. If the specific vehicle lift points are not identified, or if the vehicle has additional or uniquely positioned payload, have a qualified person calculate the vehicle center of gravity or have the vehicle center of gravity determined at a vehicle scale. Load the vehicle with the center of gravity midway between adapters.

⚠ WARNING

Make sure vehicle is neither front nor rear heavy. Center of balance should be midway between adapters as shown below.

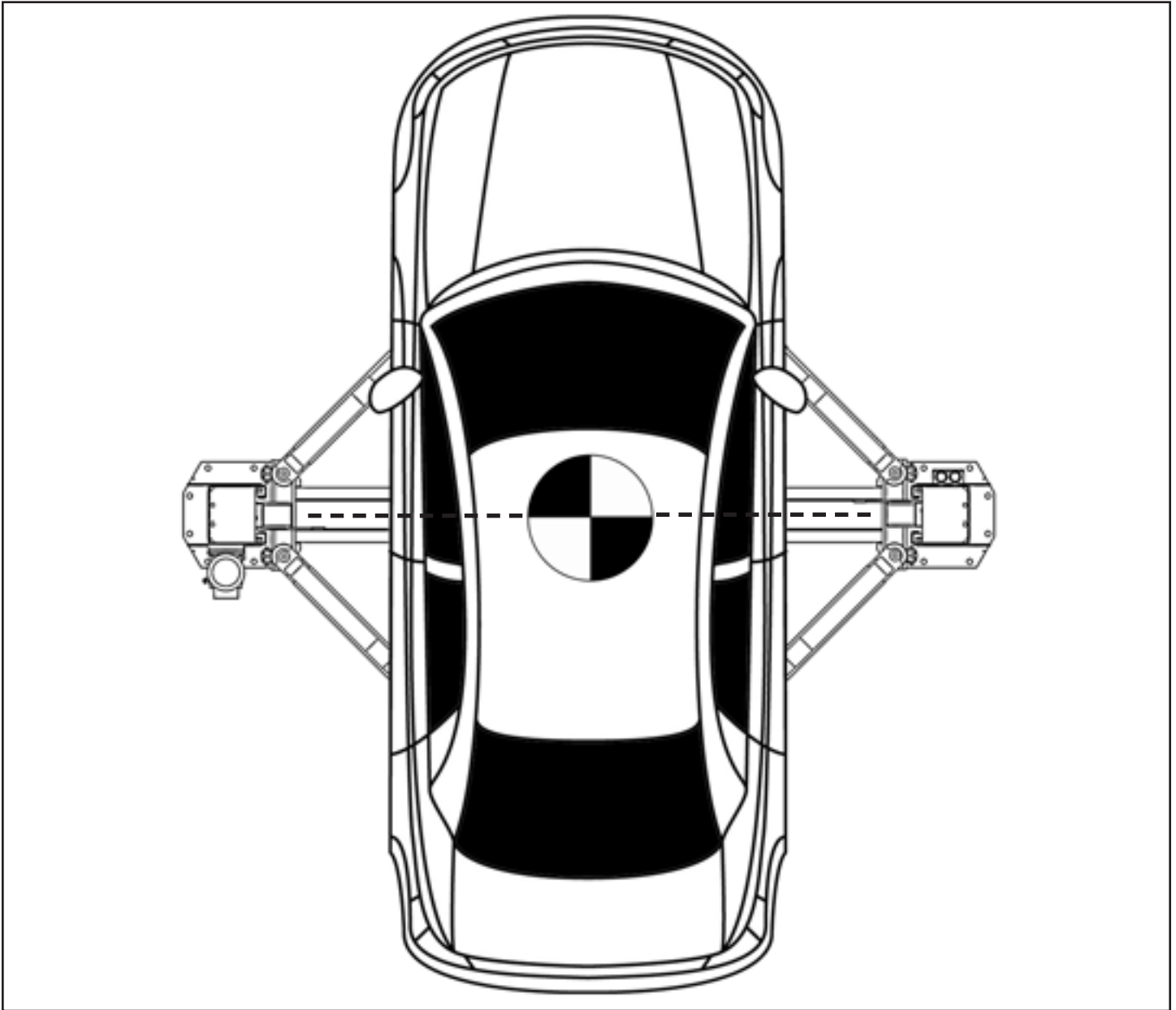

6. Push the RAISE button or rotate the control switch on the power unit.

Important Note:

Allow (2) seconds between motor starts. Failure to comply may cause motor burnout.

7. Stop before making contact with vehicle. Check arm restraint pins for engagement. If required, slightly move arm to allow restraint gear and pawl to mesh. **DO NOT** hammer arm restraint pin down as this will damage the restraint gear teeth.
8. Raise vehicle until tires clear the floor.
9. Stop and check adapters for secure contact at vehicle manufacturer's recommended lift points.

10. Continue to raise to desired height only if vehicle is secure on lift.
11. **DO NOT** go near or under a raised vehicle if all four adapters are not in secure contact with vehicle at vehicle manufacturer's recommended lift points.
12. Repeat entire loading and raising procedures if required.
13. Lower lift on to the safety locks.



VISUALLY CONFIRM THAT ALL PRIMARY SAFETY LOCKS ARE ENGAGED BEFORE ENTERING WORK AREA.

Suspension components on this lift are intended to raise and lower lift only and are not meant to be load holding devices. Remain clear of elevated lift unless visual confirmation is made that all primary safety locks are fully engaged and the lift is **LOWERED** onto the safety locks, refer to installation / operation manual for proper safety lock procedures and / or further instruction.

- **DO NOT** enter work area or go under vehicle if safety locks are not engaged.
- **CLEAR AREA** if vehicle is in danger of falling.
- **DO NOT** position yourself between a wall and the lift. If the vehicle falls in that direction, you may be severely injured.
- Before attempting to lift pickup trucks or other truck frame vehicles, be sure that:
 - Vehicle frame is strong enough to support its weight and has not been weakened by modification or corrosion.
 - Vehicle individual axle weight does not exceed one half lift capacity.
 - Adapters are in secure contact with frame at vehicle manufacturers recommended lift points.
 - Vehicle is stable on lift and neither front nor "tail" heavy.
- Avoid excessive rocking of vehicle while on lift.
- Always use safety stands as needed or when removing or installing heavy components.

TO LOWER THE LIFT



When lowering the lift **PAY CAREFUL ATTENTION** that all personnel and objects are kept clear. **ALWAYS** keep a visual line of site on the lift **AT ALL TIMES**. **ALWAYS** make sure that **ALL LOCKS** are disengaged. If one of the locks inadvertently locks on descent the lift and / or vehicle may disrupt causing personal injury or death.

1. Remove all tools or other objects from the lift area.
2. Raise lift off safety locks. Make sure you raise the lift by at least two inches to allow adequate clearance for the locks to clear.
3. Pull both safety lock release cables.
4. Push the **LOWERING** valve handle on the power unit to lower.
5. Remain clear of lift when lowering vehicle. Observe pinch point warning decals.

6. Remove adapters from under vehicle and swing arms to full drive-thru position before moving vehicle.
7. **NEVER** drive over the lift arms.
8. If lift is not operating properly, do not use until adjustment or repairs are made by qualified lift service personnel.

MAINTENANCE INSTRUCTIONS



If you are not completely familiar with automotive lift maintenance procedures; **STOP**: Contact the factory for instructions. To avoid personal injury, permit only Trained Lift Service Personnel to perform maintenance on this equipment.

- Always keep bolts tight. Check periodically.
- Always keep lift components clean.
- Always if oil leakage is observed, call local service representative.
- Always if electrical problems develop, call local service representative.
- Always replace **ALL FAULTY PARTS** before lift is put back into operation.
- Daily: Make a visual inspection of **ALL MOVING PARTS** and check for excessive signs of wear.
- Daily: Check Safety Locks to insure they are in good operating condition.
- Daily: Check cables and sheaves for wear. Replace worn parts as required with genuine Danmar parts.
- Daily: Inspect adapters for damage or excessive wear. Replace as required with genuine Danmar parts.
- Weekly: Lubricate all rollers with white lithium grease.
- Weekly: Check all cable connections, bolts and pins to insure proper mounting.
- Monthly: Check equalizer cable tension. Adjust per lift installation instructions.
- Monthly: Lubricate locking latch shafts. Push latch handle several times for oil to penetrate pivot points.
- Every 3 Months: Check anchor bolts for tightness. Anchors should be torqued to 90 ft/lbs
- Semi Annually: Check fluid level of lift power unit and refill if required per lift installation instructions.
- Replace all caution, warning or safety related decals on the lift if unable to read or missing. Reorder labels from Danmar.
- Refer to ANSI/ALI ALOIM booklet for periodic inspection checklist and maintenance log sheet.

REQUIRED MONTHLY MAINTENANCE

- ❑ Check all arm adjusting locks for proper operation.
- ❑ Check all cables connections, bolts and pins to insure proper mounting and torque.
- ❑ Visually inspect safety locks for proper operation.
- ❑ Lubricate columns with white lithium grease.
- ❑ Inspect all anchors bolts and retighten if necessary.
- ❑ Check all columns for squared and plumb.
- ❑ Inspect all pivot arms pins making sure they are properly secure.
- ❑ Check equalizer cable tension, and adjust if necessary.

WARNING

1. Never use lift if cement anchor bolts are loose or any component of the lift is found to be defective.
2. Never operate lift if any person or equipment is below the vehicle.
3. Never exceed the rated lift capacity.
4. Ensure the safety locks are engaged before any attempt is made to work on or near the vehicle.
5. Never leave lift in elevated position unless the safety locks are engaged.
6. Do not permit electric motor to get wet! Motor damage caused by dampness is not covered under warranty.

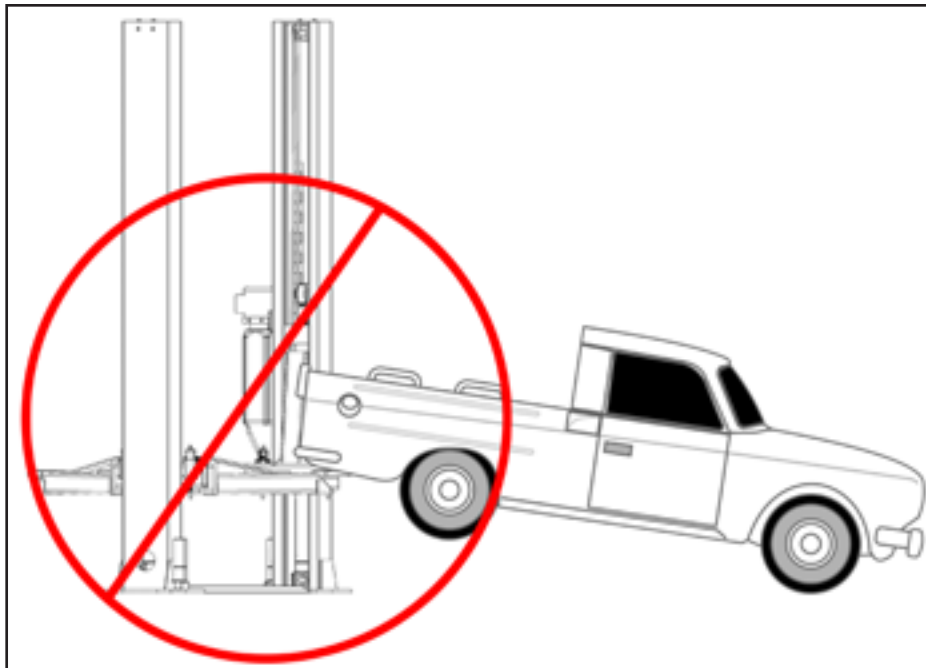

NEVER LIFT ANY VEHICLE IN ANY MANNER WITH LESS THE ALL FOUR (4) ARMS. RATED CAPACITY OF EACH LIFT ARM IS NO GREATER THAT ONE FOURTH (1/4) OF THE OVERALL LIFT CAPACITY.

WIRE ROPE INSPECTION AND MAINTENANCE

- ◇ Lifting cables should be replaced every 3 - 5 years or when visible signs of damage are apparent.

DO NOT USE LIFT WITH DEFECTIVE / WORN CABLES.

- ◇ Lifting cables should be maintained in a well lubricated condition at all times. Wire rope is only fully protected when each wire strand is lubricated both internal and external. Excessive wear will shorten the life of the wire rope. The factory suggested wire rope lubricant that penetrates to the core of the rope and provides long term lubrication between each individual strand is 90-WT gear oil or ALMA-SOL® Wire Rope Lubricant. In order to make sure that the inner layers of the rope remain well lubricated, lubrication should be carried out at intervals not exceeding three months during operation.
- ◇ All sheaves and guide rollers in contact with the moving rope should be given regular visual checks for surface wear and lubricated to make sure that they run freely. This operation should be carried out at appropriate intervals generally not exceeding three months during operation. For all sheave axles, the factory recommends standard wheel bearing grease. For all sheaves and / or guide rollers, the factory recommends 90-WT gear oil or similar heavy lubricant applied by any method including pump / spray dispensing, brush, hand and / or swabbing.

HOW OFTEN TO INSPECT

- ◇ Lifting cables should be visually inspected at least once each day when in use, as suggested by American Petroleum Institute (API) RP54 guidelines.
- ◇ Any lifting cables that have met the criteria for removal must be immediately replaced.

WHEN TO REPLACE LIFTING CABLES DUE TO BROKEN WIRES

- ◇ Lifting cables should be removed from service when you see 6 randomly distributed broken wires within any one lay length, or three broken wires in one strand within one lay length.

OTHER REASONS TO REPLACE LIFTING CABLES

- ◇ Corrosion that pits the wires and / or connectors.
- ◇ Evidence of kinking, crushing, cutting, bird caging or a popped core.
- ◇ Wear that exceeds 10% of a wire's original diameter.
- ◇ Evidence of heat damage.

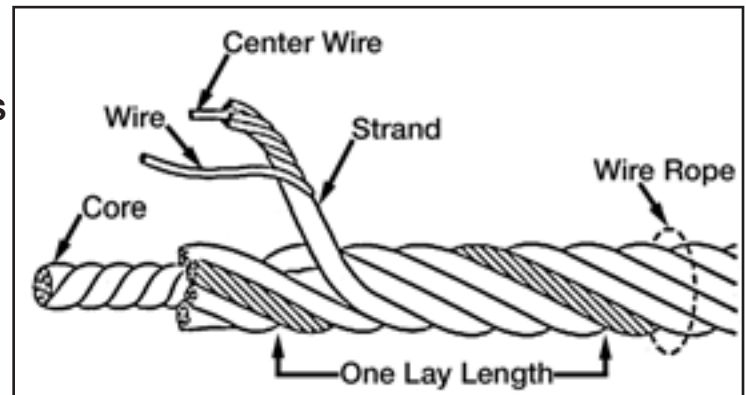

HOW TO FIND BROKEN WIRES

- ◇ The first step is to relax your rope to a stationary position and move the pickup points off the sheaves. Clean the surface of the rope with a cloth or a wire brush if necessary so you can see any breaks.
- ◇ Flex the rope to expose any broken wires hidden in the valleys between the strands.
- ◇ Visually check for any broken wires. One way to check for crown breaks is to run a cloth along the rope to check for possible snags.
- ◇ With an awl, probe between wires and strands and lift any wires that appear loose. Evidence of internal broken wires may require a more extensive rope examination.

LIFT LOCKOUT / TAGOUT PROCEDURE

Purpose:

This procedure establishes the minimum requirements for the lockout of energy that could cause injury to personnel by the operation of lifts in need of repair or being serviced. All employees shall comply with this procedure.

Responsibility:

The responsibility for assuring that this procedure is followed is binding upon all employees and service personnel from outside service companies (i.e., authorized installers, contractors, etc.). All employees shall be instructed in the safety significance of the lockout procedure by the facility owner/manager. Each new or transferred employee along with visiting outside service personnel shall be instructed by the owner/manager (or assigned designee) in the purpose and use of the lockout procedure.

Preparation:

Employees authorized to perform lockout shall ensure that the appropriate energy isolating device (i.e., circuit breaker, fuse, disconnect, etc.) is identified for the lift being locked out. Other such devices for other equipment may be located in close proximity of the appropriate energy isolating device. If the identity of the device is in question, see the shop supervisor for resolution. Assure that proper authorization is received prior to performing the lockout procedure.

Sequence of Lockout Procedure:

1. Notify all affected employees that a lockout is being performed and the reason for it.
2. Unload the subject lift. Shut it down and assure the disconnect switch is "OFF" if one is provided on the lift.
3. The authorized lockout person operates the main energy isolation device removing power to the subject lift.
 - If this is a lockable device, the authorized lockout person places the assigned padlock on the device to prevent its unintentional reactivation. An appropriate tag is applied stating the person's name, at least 3" x 6" in size, an easily noticeable color, and states not to operate device or remove tag.
 - If this device is a non-lockable circuit breaker or fuse, replace with a "dummy" device and tag it appropriately as mentioned above.
4. Attempt to operate lift to assure the lockout is working. Be sure to return any switches to the "OFF" position.
5. The equipment is now locked out and ready for the required maintenance or service.

Restoring Equipment to Service:

1. Ensure the repair is complete and the area is clear of tools, vehicles, and personnel.
2. At this point, the authorized person can remove the lock (or dummy circuit breaker or fuse) & tag and activate the energy isolating device so that the lift may again be placed into operation.

Rules for Using Lockout Procedure:

Use the Lockout Procedure whenever the lift is being repaired or serviced, waiting for repair when current operation could cause possible injury to personnel, or for any other situation when unintentional operation could injure personnel. No attempt shall be made to operate the lift when the energy isolating device is locked out.



REQUIRED SAFETY LABELS

!WARNING

WIRE ROPE INSPECTION AND MAINTENANCE



- Lifting cables should be replaced every (3) three years or when visible signs of damage are apparent. **DO NOT USE LIFT WITH DEFECTIVE OR WORN CABLES.**
- Wire rope should be maintained in a well-lubricated condition at all times. Wire rope is only fully protected when each wire strand is lubricated both internal and external. Excessive wear will shorten the life of the wire rope. The factory suggests wire rope lubricant that penetrates to the core of the rope and provides long-term lubrication between each individual strand. In order to make sure that the inner layers of the rope remain well lubricated, lubrication should be carried out at intervals not exceeding three (3) months during operation.
- All sheaves and guide rollers in contact with the moving wire rope should be given regular visual checks for surface wear and lubricated to make sure that they run freely. This operation should be carried out at appropriate intervals generally not exceeding three (3) months during operation. For all sheave axles, the factory recommends standard wheel bearing grease. For all sheaves and/or guide rollers, the factory recommends 90-WT gear oil or similar heavy lubricant applied by any method including pump/spray dispensing, brush, hand and/or swabbing.

Failure to read, understand and follow these instructions may cause death or serious injury. Read and understand these instructions before using lift.

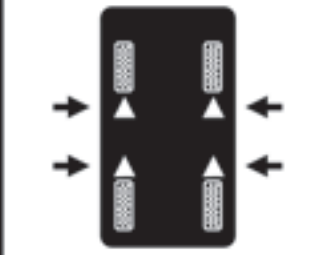

NOTICE		<p style="text-align: center;">Read operating and safety manuals before using lift.</p> <p style="text-align: right;">©</p>
NOTICE		<p style="text-align: center;">Proper maintenance and inspection is necessary for safe operation.</p> <p style="text-align: right;">©</p>
NOTICE		<p style="text-align: center;">Do not operate a damaged lift.</p> <p style="text-align: right;">©</p>
<p>The messages and pictographs shown are generic in nature and are meant to generally represent hazards common to all automotive lifts regardless of specific style.</p> <p>Funding for the development and validation of these labels was provided by the Automotive Lift Institute, PO Box 85 Cortland, NY 13045.</p> <p>Replacement label sets may be obtained from the original lift manufacturer and ALI's member companies. They are protected by copyright.</p> <p style="text-align: right;"> www.autolift.org © 2009 by ALI, Inc. ALI/WL1018 </p>		

<p>⚠ CAUTION</p>  <p>Lift to be used by trained operator only.</p>	<p>⚠ CAUTION</p>  <p>Authorized personnel only in lift area.</p>
--	--

<p>⚠ WARNING</p>  <p>Clear area if vehicle is in danger of falling.</p>	<p>⚠ WARNING</p>  <p>Position vehicle with center of gravity midway between adapters.</p>
--	---

<p>⚠ CAUTION</p>  <p>Use vehicle manufacturer's lift points.</p>	<p>⚠ CAUTION</p>  <p>Always use safety stands when removing or installing heavy components.</p>
---	--

<p>⚠ WARNING</p>  <p>Remain clear of lift when raising or lowering vehicle.</p>	<p>⚠ WARNING</p>  <p>Avoid excessive rocking of vehicle while on lift.</p>
---	---

<p>⚠ CAUTION</p>  <p>Use height extenders when necessary to ensure good contact.</p>	<p>⚠ CAUTION</p>  <p>Auxiliary adapters may reduce load capacity.</p>
--	---

<p>⚠ WARNING</p>  <p>Do not override self-closing lift controls.</p>	<p>⚠ WARNING</p>  <p>Keep feet clear of lift while lowering.</p>
---	--

The messages and pictographs shown are generic in nature and are meant to generally represent hazards common to all automotive lifts regardless of specific style.

Funding for the development and validation of these labels was provided by the Automotive Lift Institute, PO Box 85 Cortland, NY 13045.

Replacement label sets may be obtained from the original lift manufacturer and ALI's member companies. They are protected by copyright.

www.autolift.org © 2009 by ALL, Inc. ALI/WL101c

The messages and pictographs shown are generic in nature and are meant to generally represent hazards common to all automotive lifts regardless of specific style.

Funding for the development and validation of these labels was provided by the Automotive Lift Institute, PO Box 85 Cortland, NY 13045.

Replacement label sets may be obtained from the original lift manufacturer and ALI's member companies. They are protected by copyright.

www.autolift.org © 2009 by ALL, Inc. ALI/WL101w

OPERATIONAL TEST PROCEEDURE

- ◇ Load vehicle as per diagram below using the ALI lifting points guide provided.
- ◇ Raise vehicle approximately 6" - 12" off the ground and check for stability.
- ◇ Visually inspect for leaks and ensure that all operating components are secure.
- ◇ Raise vehicle to the desired locking point and lower the lift on to the lock and relieve the hydraulic pressure.
- ◇ Raise the vehicle off the locks, allow clearance for the safety lock to clear the locking block on the carriage.
- ◇ Ensure that both locks release before descending.
- ◇ Lower vehicle until all 4 arm restraint gears are completely released.
- ◇ Reference ANSI/ALI ALIS for all safety data.

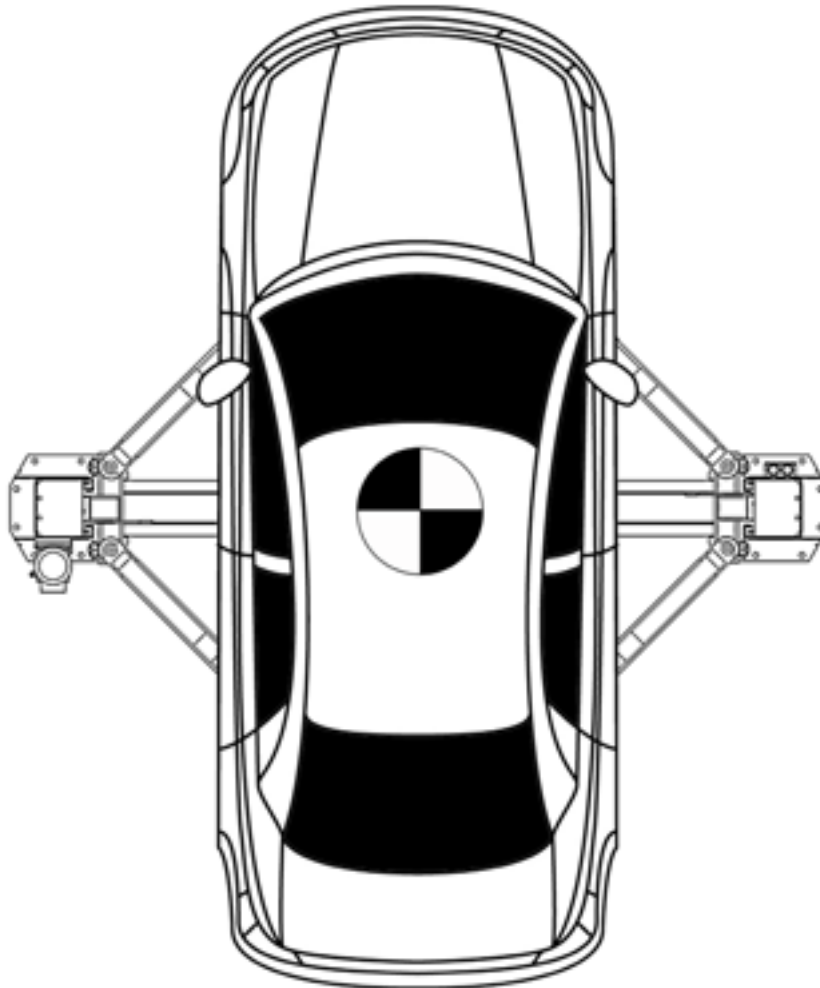



- **DO NOT** leave the controls while the lift is still in motion.
- **DO NOT** stand directly in front of the vehicle or in the bay when vehicle is being loaded or driven into position.
- **DO NOT** go near vehicle or attempt to work on the vehicle when being raised or lowered.
- **REMAIN CLEAR** of lift when raising or lowering vehicle.
- **DO NOT** rock the vehicle while on the lift or remove any heavy component from vehicle that may cause excessive weight shift.
- **DO NOT** lower the vehicle until people, materials, and tools are clear.
- **ALWAYS ENSURE** that the safety locks are engaged and lowered on to the safety ladders before any attempt is made to work on or near vehicle.
- Some vehicle maintenance and repair activities may cause the vehicle to shift. Follow the manufacturer's guidelines when performing these operations. The use of jack stands or alternate lift points may be required when completing some repairs.
- **READ AND UNDERSTAND** all safety warning procedures before operating lift.
- **KEEP HANDS AND FEET CLEAR.** Remove hands and feet from any moving parts. Keep feet clear of lift when lowering, and avoid pinch points.
- **ONLY TRAINED OPERATORS** should operate this lift. All non-trained personnel should be kept away from work area.
- **NEVER** let non-trained personnel come in contact with, or operate lift.
- **USE LIFT CORRECTLY.** Use lift in the proper manner. Never use lifting adapters other than what is approved by the manufacturer.
- **DO NOT** override self closing lift controls.
- **CLEAR AREA** if vehicle is on danger of falling.
- **CHECK FOR DAMAGED PARTS.** Check for alignment of moving parts, breakage of parts or any condition that may affect safe operation. Do not use lift if any component is broken or damaged.
- **NEVER** remove safety related components from the lift. Do not use lift if safety related components are damaged or missing.
- When the lift is being lowered, make sure everyone is standing at least six feet away.
- Be sure there are no jacks, tools, equipment, left under the lift before lowering.
- Always lower the vehicle carefully and smoothly.

TROUBLESHOOTING GUIDE

LIFT WILL NOT RAISE

POSSIBLE CAUSE

1. Air in oil, (1,2,8,13)
2. Cylinder binding, (9)
3. Cylinder leaks internally, (9)
4. Motor run backward under pressure, (11)
5. Lowering valve leaks, (3,4,6,10,11)
6. Motor runs backwards, (7,14,11)
7. Pump damaged, (10,11)
8. Pump won't prime, (1,8,13,14,3,12,10,11)
9. Relief valve leaks, (10,11)
10. Voltage to motor incorrect, (7,14,11)

REMEDY INSTRUCTION

1. Check for proper oil level. The oil level should be up to the bleed screw in the reservoir with the lift all the way down.
2. Bleed cylinders.
3. Flush Release valve, hold release handle down and start unit for 15 seconds allowing possible contamination to break up.
4. Dirty oil, replace oil with clean AW-32 hydraulic fluid or Dextron III or VI ATF.
5. Tighten fasteners to recommended torques settings.
6. Check for free movement of release. If handle does not move freely, replace bracket or handle assembly.
7. Check motor is wired correctly. Compare wiring of motor to electrical diagram on drawing.
8. Oil seal is damaged or cocked. Replace oil seal around pump shaft.
9. Consult Lift Manufacturer.
10. Replace with new part.
11. Return unit for repair.
12. Check pump mounting bolts. Bolts should be torqued to 15 - 18 ft. lbs.
13. Inlet screen clogged. Clean inlet screen or replace.
14. Check wall outlet voltages and wiring. Make sure unit and wall outlet are wired

MOTOR WILL NOT RUN

POSSIBLE CAUSE

1. Fuse blown, (5,2,1,3,4)
2. Limit switch burned out, (1,2,3,4)
3. Microswitch burned out, (1,2,3,4)
4. Motor burned out, (1,2,3,4,6)
5. Voltage to motor incorrect, (2,1,8)

REMEDY INSTRUCTION

1. Check for correct voltage. Compare supply voltage with voltage on motor name tag. Check that the wire is sized correctly. N.E.C. table 310-12 requires AWG 10 for 25 Amps.
2. Check motor is wired correctly. Compare wiring of motor to electrical diagram on drawing.
3. Don't use extension cords. According to N.E.C. : " The size of the conductors should be such that the voltage drop would not exceed 3% to the farthest outlet for power". Do not run motor at 115 VAC – damage to the motor will occur.
4. Replace with new part.
5. Reset circuit breaker / fuse.
6. Return unit for repair.
7. See Installation Manual.
8. Check wall outlet voltage and wiring. Make sure unit and wall outlet is wired properly. Motor must run at 208/230 VAC.

LIFT LOWERS SLOWLY OR NOT AT ALL

POSSIBLE CAUSE

1. Cylinders binding, (1)
2. Release valve clogged, (5,4,2,3)
3. Pressure fitting too long, (6)

REMEDY INSTRUCTION

1. Consult Lift Manufacturer.
2. Replace with new part.
3. Return for repair.
4. Check oil. Use clean AW-32 hydraulic oil or Dexron III or VI automatic transmission fluid only. If fluid is contaminated, replace with clean fluid and clean entire system.
5. Clean release valve. Wash release valve in solvent and blow out with air.
6. Replace fitting with short thread lead.

WILL NOT RAISE LOADED LIFT

POSSIBLE CAUSE

1. Air in oil, (1,2,3,4)
2. Cylinder binding, (5)
3. Cylinder leaks internally, (5)
4. Lift overloaded, (6,5)
5. Lowering valve leaks, (7,8,1,5,9)
6. Motor runs backwards, (10,12,9)
7. Pump damaged, (5,9)
8. Pump won't prime, (1,2,3,4,5,11,9)
9. Relief valve leaks, (8,5,9)
10. Voltage to motor incorrect, (10,12,5)

REMEDY INSTRUCTION

1. Check oil level. The oil level should be up to the bleed screw in the reservoir with the lift all the way down.
2. Check / Tighten inlet tubes or Replace inlet hose assembly.
3. Oil seal is damaged or cocked. Replace oil seal around pump shaft.
4. Bleed cylinders.
5. Consult Lift Manufacturer.
6. Check vehicle weight. Compare weight of vehicle to weight limit of the lift.
7. Flush release valve. Hold release handle down and start unit allowing it to run for 15 seconds.
8. Replace with new part.
9. Return unit for repair.
10. Check if motor is wired correctly. Compare wiring of motor to electrical diagram on power unit drawing.
11. Inlet screen clogged. Clean inlet screen or replace.
12. Check wall outlet voltage and wiring. Make sure unit and wall outlet is wired properly.

LIFT WILL NOT STAY UP

POSSIBLE CAUSE

1. Air in oil, (1,2,3)
2. Check valve leaks, (6)
3. Cylinders leak internally, (7)
4. Lowering valve leaks, (4,5,1,7,6)
5. Leaking fittings, (8)

REMEDY INSTRUCTION

1. Check oil level. The oil level should be up to the bleed screw in the reservoir with the lift all the way down.
2. Oil seal is damaged and cocked. Replace oil seal around pump shaft.
3. Bleed cylinder.
4. Flush release valve. Hold release handle down and start unit allowing it to run for 15 seconds.
5. Replace with new valve.
6. Return unit for repair.
7. Consult Lift Manufacturer.
8. Check complete hydraulic system for leaks. Tighten all hydraulics fittings and inspects all hoses.

WARRANTY INFORMATION

LIGHT DUTY TWO POST AUTO LIFT

DELIVER THESE INSTRUCTIONS TO THE LIFT OWNER !

READ THIS ENTIRE MANUAL BEFORE INSTALLATION & OPERATION BEGINS.

This instruction manual has been prepared especially for you.
Your new lift is the product of over 25 years of continuous research, testing and development and is the most technically advanced lift on the market today.

**RECORD HERE THE FOLLOWING INFORMATION
WHICH IS LOCATED ON THE SERIAL NUMBER DATA PLATE AND THE POWER UNIT DATA PLATE.
YOU CAN ALSO RECORD THE FOLLOWING INFORMATION ONLINE AT
[HTTP://WWW.DANNMAR.COM/WARRANTY.ASP](http://www.dannmar.com/warranty.asp)**

Lift Serial #:	_____	Power Unit Serial #:	_____
Lift Model #:	_____	Power Unit Model #:	_____
Lift Manufacturing Date:	_____	Power Unit Manufacturing Date:	_____

WARRANTY

Dannmar Lifts are covered under warranty for three years on equipment structure, to be free of defects in material and workmanship. Power units, hydraulic cylinders, and all other assembly components such as cables, chains, valves, switches etc. are covered under warranty for one year against defects in material or workmanship under normal use. Dannmar Worldwide shall repair or replace at their option for the warranty period those parts returned to the factory freight prepaid which prove upon inspection to be defective.

The warranty does not extend to:

- Defects caused by ordinary wear, abuse, misuse, shipping damage, improper installation, voltage or lack of required maintenance;
- Damages resulting from purchaser's neglect or failure to operate product instructions provided in the owner's manual (s) and / or other accompanying literature.
- Normal wear items or service normally required to maintain the product in a safe operating condition;
- Any component damaged in shipment;
- Other items not listed but may be considered general wear parts;
- Damage caused by rain, excessive humidity, corrosive environments or other contaminants.

This warranty is exclusive and in lieu of all other warranties expressed or implied. In no event shall the manufacturer be liable for special, consequential or incidental damages for the breach or delay in performance of the warranty.

The manufacturer reserves the right to make design changes or add improvements to its product line without incurring any obligation to make such changes on product sold previously. Warranty adjustments within the above stated policies are based on the model and serial number of the equipment. This data must be furnished with all warranty claims.

GENERAL DISCLAIMER

In addition to all claims listed on each of the following individual WARRANTY pages, the following GENERAL DISCLAIMERS apply.

1. The purchaser of any DANNMAR product (Buyer) assumes the risk of verifying all materials or resources used or relied on. In no event will DANNMAR be liable to the Buyer or to anyone else for any decision made or action taken in reliance on information obtained from any DANNMAR website or from any DANNMAR dealer, or third-party website, or any online or published catalog.
2. DANNMAR has exclusive title and ownership rights including all intellectual property right throughout the world for all material and content contained on any DANNMAR website or from any DANNMAR online or published catalog.
3. DANNMAR warrants that all products shown on any DANNMAR website or in any online or published catalog conform to DANNMAR published specifications only and are free from defects in material or workmanship as more fully set forth in the Warranty for the specific product.
4. DANNMAR websites may contain hypertext or other links to websites not owned or controlled by DANNMAR. Links to other computer systems or websites are not supervised nor regularly reviewed by DANNMAR. DANNMAR specifically disavows legal responsibility for any information, personal opinions, guidance, advice or instruction that a Buyer receives from others or other websites.
5. Materials, design, specifications, images and other content from any DANNMAR website, or any other DANNMAR affiliate or dealer website, or any DANNMAR online or published catalog are subject to change. DANNMAR takes no responsibility for improper use or any results thereof. DANNMAR reserves the right to make changes to all published warranties, website content, or published content without incurring any obligation to notify the Buyer or public that changes were made.
6. DANNMAR products are provided and sold as is without any express or implied warranties including warranties of merchantability or fitness for particular purpose, other than the published written limited Warranty for the specific product or as required by law.
7. DANNMAR makes no promises, guarantees or assurances that our products meet any state, county, federal or international mandated permit, license, code, standard, certification, or any other mandate other than what is listed or shown on DANNMAR website(s), or any DANNMAR online or published catalog. Not all DANNMAR lift models meet the standards as prescribed by ANSI/ALI ALCTV-(current edition) or ANSI/UL 201. Consult www.autolift.org for a complete list of lift models that meet ANSI/ALI ALCTV-(current edition) or ANSI/UL 201, or contact DANNMAR via contact@danmar.com. Buyer assumes full responsibility for any state, county, federal or international mandated permit, license, code, standard, certification, or any other mandate required related to the installation and/or operation at any DANNMAR product. DANNMAR will not be responsible for any charges, fines, liens, or other levies imposed on the Buyer related to any special or regional structural, seismic or any other building code and/or codes such as the Uniform Building Code (UBC), International Building Code (IBC) or any other state, county, federal or international mandated permit, license, code, standard, certification, or other mandate, law, rule, regulation or directive by any other agency, government, administrations, or corporations whether state, county, federal, or international mandated.
8. In no event will DANNMAR be liable for any special, incidental, or consequential damages based on breach of warrant, breach of contract, negligence, strict tort, or any other legal theory. Damages that DANNMAR will not be responsible for include, but are not limited to: loss of profits; loss of savings or revenue; loss of use of the product or any associated equipment; cost of capital; cost of any substitute equipment, facilities, or services; downtime; the claims of third parties, including customers; and injury to property. This limitation does not apply to damages caused by breach of the warranty of title and against infringements or to claims for personal injury.
9. Unless modified in a writing signed by both parties, it is understood that DANNMAR published Warranties and

DANNMAR Terms and conditions of Sale are to be the complete and exclusive agreement (Agreement) between the parties superseding all oral or written prior agreements and all other communications between the parties relating to the subject matter of said Agreement, including statements made by sales persons. No employee of DANNMAR or any other party is authorized to make any warranty in addition to those made in the Agreement. The buyer is warned, therefore, to check all Warranties and review in full detail the Terms and Conditions of Sale carefully to see that it correctly reflects those terms that are important to the Buyer.

10. The Agreement allocates the risks of product failure between DANNMAR and the buyer. This allocation is recognized by both parties and is reflected in the price of the goods. Buyer acknowledges that they have read and fully understand the Agreement, and are bound by its terms. Some States do not allow limitations on how long an implied warranty lasts, so the above limitation may not apply to some Buyers. This warranty gives the Buyer specific legal rights. The Buyer may have other rights also which vary from State to State.
11. ANY ACTION FOR BREACH OF WARRANTY MUST BE COMMENCED WITHIN 60-DAYS FOLLOWING EXPIRATION DATE OF ANY WARRANTY PROVISION OR TERM.

LIMITED WARRANTY - TWO-POST LIFTS/FOUR-POST LIFTS

Better Products - Better Service - Better Value

Duration: From the date of purchase by original Purchaser or 36 months from the date of shipment by DANNMAR or whichever comes first.

- ✓ **Three Years (36-Months) Warranty** on the lift structure
- ✓ **One Year (12-Months) Warranty** on operating components

Limited Warranty

1. Who gives this warranty (Warrantor): DANNMAR Inc., 646 Flinn Ave. Moorpark, CA 93021
2. Who receives this warranty (Purchaser): The original Purchaser (other than for purpose of resale)
3. What products are covered by this warranty: Any DANNMAR Two-Post or Four-Post Vehicle Service Lift**
4. What is covered under this warranty: manufacturer defects due to material and/or workmanship with the exceptions noted below.
5. What is not covered under this warranty:
 - a. Any failure that results from Purchaser's abuse, neglect or failure to install, operate, maintain or service product in accordance with instructions provided in the owner's manual(s) supplied
 - b. Any damage caused by overloading lift beyond rated capacity
 - c. Items or service normally required to maintain the product, i.e. lubricants, oil, etc.
 - d. Items considered general wear parts such as rubber pads, lifting cables, etc. unless wear or failure is a direct result of manufacturer defect due to material and/or workmanship
 - e. Any component damaged in shipment or any failure caused in whole or in part by installing or operating lift under conditions not in accordance with installation and operation guidelines or damaged by contact with tools or surroundings
 - f. Motor or pump failure caused by rain, excessive humidity, corrosive environments or other contaminants
 - g. Rusted components due to improper maintenance or corrosive environments
 - h. Cosmetic defects that do not interfere with product functionality
 - i. Damage due to incorrect voltage or improper wiring
 - j. Any incidental, indirect, or consequential loss, damage, or expense that may result from any defect, failure, or malfunction of DANNMAR Inc. Product
 - k. All electrical components (excluding power unit) are guaranteed for one year against defects in workmanship and/or materials when the lift is installed and used according to specifications.
 - l. The cost of labor to make repairs or replacements.
 - m. Shipping costs.
6. Responsibilities of Warrantor under this warranty: Repair or replace, at Warrantor's option, component which is defective, has malfunctioned and/or failed to conform within duration of the warranty period. DANNMAR will not pay labor costs.
7. Responsibilities of Purchaser under this warranty:
 - a. Provide dated proof of purchase and maintenance records
 - b. In some cases, components may be required to be shipped to the nearest DANNMAR Authorized Service center. Freight costs must be borne by the Purchaser
 - c. Use reasonable care in the installation, operation and maintenance of the products as described in the owner's manual(s).
8. When Warrantor will perform repair or replacement under this warranty: Repair or replacement will be scheduled and serviced according to the normal work flow at the servicing location, and depending on the availability of replacement parts.
9. The warranty will be voided if the product is not installed in accordance with the instructions provided by Danmar.
10. This Warranty is further limited by DANNMAR'S General Disclaimer and Terms and Conditions of Sale.

Limitation of Liability

DANNMAR shall have no obligation pursuant to this Warranty with respect to products which in our sole judgment have been altered, damaged, misused, abused, badly worn, lost or improperly installed or maintained. This Warranty is null and void if the customer or any other person other than an authorized representative of DANNMAR has made any attempt to service or modify the tool prior to its return to DANNMAR under this Warranty. In no event will either party be liable for any damage caused by the other party's failure to fulfill its responsibilities, under these terms and conditions. In no event will either party be liable for any lost profits, lost savings, incidental damage, or other economic consequential damages. **DANNMAR products are provided and sold as is without any express or implied warranties including warranties of merchantability or fitness for particular purpose.** No warranties, expressed or implied, will apply after the period set forth in this Limited Warranty. DANNMAR may modify these terms and conditions at any time by either providing the customer with written notice or posting such revised terms on www.DANNMAR.com. Such revised terms shall be effective thirty days from the date of such written notice or posting.



FOR PARTS OR SERVICE CONTACT:

Dannmar Equipment, Inc.

646 Flinn Ave, Suite A

Moorpark, CA 93021

Tel: 1-844-629-5291

Fax: 1-805-530-1909

www.dannmar.com

ALTHOUGH EVERY EFFORT HAS BEEN TAKEN TO ENSURE COMPLETE AND ACCURATE INSTRUCTIONS HAVE BEEN INCLUDED IN THIS MANUAL, POSSIBLE PRODUCT UPDATES, REVISIONS AND OR CHANGES MAY HAVE OCCURRED SINCE THE PRINTING OF THIS MANUAL. DANNMAR EQUIPMENT RESERVES THE RIGHT TO CHANGE SPECIFICATIONS WITHOUT INCURRING ANY OBLIGATION FOR EQUIPMENT PREVIOUSLY OR SUBSEQUENTLY SOLD. DANNMAR EQUIPMENT IS ALSO NOT RESPONSIBLE FOR TYPOGRAPHICAL ERRORS.