

Pleasant Hearth®

VENT-FREE GAS LOG SET

MODEL # VFL2-SO18DT
VFL2-EO18DT
VFL2-SO24DT
VFL2-EO24DT
VFL2-WW18DT
VFL2-WW24DT

⚠ WARNING: This appliance is equipped for (Natural and Propane) gas. Field conversion is not permitted other than between natural or propane gases.

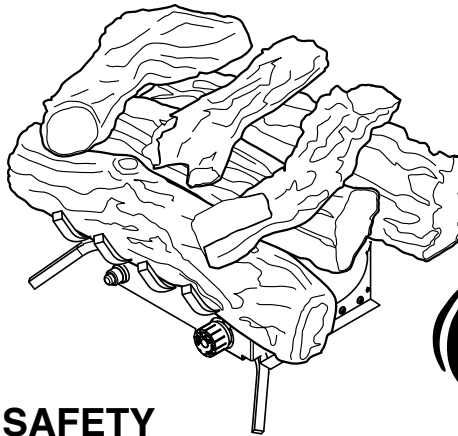

Patent Pending Dual Fuel System



Dual Fuel



ANS Z21.11.2 2013

⚠ CAUTION - FOR YOUR SAFETY

⚠ WARNING: IF THE INFORMATION IN THIS MANUAL IS NOT FOLLOWED EXACTLY, A FIRE OR EXPLOSION MAY RESULT CAUSING PROPERTY DAMAGE, PERSONAL INJURY OR LOSS OF LIFE.

- Do not store or use gasoline or other flammable vapors and liquids in vicinity of this or any other appliance.

WHAT TO DO IF YOU SMELL GAS

- Do not try to light any appliance.
- Do not touch any electrical switch; do not use any phone in your building.
- Immediately call your gas supplier from a neighbor's phone. Follow the gas supplier's instructions.
- If you cannot reach your gas supplier, call the fire department.
- Installation and service must be performed by a qualified installer, service agency or the gas supplier.

⚠ WARNING: Do not attempt to access or change the setting of the fuel selection means. Access to and adjustment of the fuel selection means must only be performed by a qualified service person when connecting this appliance to a specified fuel supply at the time of installation.

Change of the selector setting to other than the fuel type specified at the time of installation could damage this appliance and render it inoperable.

The installer shall replace the access cover before completing the installation and operating this appliance.

This is an unvented gas-fired heater. It uses air (oxygen) from the room in which it is installed. Provisions for adequate combustion and ventilation air must be provided. Refer to Air For Combustion and Ventilation section on page 9 of this manual.

INSTALLER: Leave this manual with the appliance.
CONSUMER: Retain this manual for future reference.

This appliance may be installed in an aftermarket, permanently located manufactured (mobile) home, where not prohibited by local codes. This appliance is only for use with propane or natural gas. This appliance is equipped with a simple means to switch between propane and natural gas. Field conversion by any other means including the use of a kit is not permitted.

The Installation instructions for an appliance for installation on combustible flooring shall specify that when the appliance is installed directly on carpeting, tile or other combustible material, other than wood flooring, the appliance shall be installed on a metal or wood panel extending the full width and depth of the appliance.



Questions, problems, missing parts? Before returning to your retailer, call our customer service department at 1-877-447-4768, 8:30 a.m. – 4:30 p.m., CST, Monday – Friday or email us at customerservice@ghpgroupinc.com.

TABLE OF CONTENTS

Specifications	2
Important Safety Information	3
Product Identification	5
Product Features	6
Preparing for Installation.....	7
Installation	10
Unpacking.....	15
Log Assembly	21
Operation.....	22
Care and Maintenance	25
Troubleshooting.....	27
Replacement Parts	30
Warranty	31

⚠ WARNING: Read the Installation & Operating Instructions before using this appliance.
IMPORTANT: Read all instructions and warnings carefully before starting installation.
Failure to follow these instructions may result in possible injury to persons or a fire hazard and will void the warranty.

ITEM	VFL2-SO18DT VFL2-EO18DT VFL2-WW18DT		VFL2-SO24DT VFL2-EO24DT VFL2-WW24DT	
Input Rating	30,000 BTU/Hr		30,000 BTU/Hr	
Minimum Input Rating	15,000 BTU/Hr	24,000 BTU/Hr	15,000 BTU/Hr	24,000 BTU/Hr
Gas Type	Natural	LP/Propane	Natural	LP/Propane
Ignition	Electronic Push Button	Electronic Push Button	Electronic Push Button	Electronic Push Button
Manifold Pressure	5 in. W.C.	10 in. W.C.	5 in. W.C.	10 in. W.C.
Inlet Gas Pressure *For purposes of input adjustment				
Maximum	14 in. W.C.	14 in. W.C.	14 in. W.C.	14 in. W.C.
Minimum*	6 in. W.C.	11 in. W.C.	6 in. W.C.	11 in. W.C.

SERVICE HINTS

When Gas Pressure Is Too Low

- pilot will not stay lit
- burners will have delayed ignition
- heater will not produce specified heat
- for propane/LP units, propane/LP gas supply may be low

You may feel your gas pressure is too low. If so, contact your local natural or propane/LP gas supplier.



IMPORTANT SAFETY INFORMATION

IMPORTANT: Read this owner's manual carefully and completely before trying to assemble, operate, or service this heater. Improper use of this heater can cause serious injury or death from burns, fire, explosion, electrical shock, and carbon monoxide poisoning.

Only a qualified installer, service agent, or local gas supplier may install and service this product.

⚠ WARNING: Do not store or use gasoline or other flammable vapors or liquids in the vicinity of this or any other appliance.



WARNING: This appliance can be used with propane or natural gas. It is shipped from the factory adjusted for use with propane.

CARBON MONOXIDE POISONING: Early signs of carbon monoxide poisoning resemble the flu with headaches, dizziness, or nausea. If you have these signs, the heater may not be working properly. Get fresh air immediately! Have heater serviced. Some people are more affected by carbon monoxide than others. These include pregnant women, people with heart or lung disease, people who are anemic, those under the influence of alcohol, and those living in high altitudes.

NATURAL AND PROPANE/LP GAS: Natural and Propane/LP gases are odorless. An odor-making agent is added to the gas. The odor helps you detect a gas leak. However, the odor added to the gas can fade. Gas may be present even though no odor exists. Make certain you read and understand all warnings. Keep this manual for reference. It is your guide to operating this heater safely.



WARNING:

- Due to high temperatures, locate this appliance out of traffic and away from furniture and draperies.
- Heater becomes very hot when operating. Keep children and adults away from hot surfaces to avoid burns or clothing ignition. Heater will remain hot for a time after shutoff. Allow surfaces to cool before touching.
- Carefully supervise young children when they are in the room with the heater.
- Do not place clothing or other flammable material on or near the appliance. Never place any objects in the heater.
- Installation and repair should be done by a qualified service person. The appliance should be inspected before use and at least annually by a professional service person. More frequent cleaning may be required due to excessive lint from carpeting, bedding material, etc. It is imperative that control compartments, burners and circulating air passageways of the appliance be kept clean.
- Any change to this heater or its controls can be dangerous.
- Do not use any accessories not approved for use with this heater.
- Keep the appliance clear and free from combustible materials, gasoline, and other flammable vapors and liquids.
- This appliance is intended for supplemental heating.



WARNING

This product and the fuels used to operate this product (liquid propane or natural gas), and the products of combustion of such fuels, can expose you to chemicals including benzene, which is known to the State of California to cause cancer and reproductive harm.

For more information go to www.p65Warnings.ca.gov



SAFETY INFORMATION

1. This appliance is only for use with the type of gas indicated on the rating plate. This appliance is not convertible for use with other gases.
2. Do not place propane/LP supply tank(s) inside any structure. Locate propane/LP supply tank(s) outdoors.
3. If you smell gas
 - shut off gas supply
 - do not try to light any appliance
 - do not touch any electrical switch; do not use any phone in your building
 - immediately call your gas supplier from a neighbor's phone. Follow the gas supplier's instructions
 - if you cannot reach your gas supplier, call the fire department
4. This heater shall not be installed in a bedroom or bathroom.
5. Do not use this heater as a wood-burning heater. Use only the logs provided with the heater.
6. Do not add extra logs or ornaments such as pine cones, vermiculite or rock wool. Using these added items can cause sooting. Do not add lava rock inside the heater; only around the outside of the heater.
7. This heater is designed to be smokeless. If logs ever appear to smoke, turn off heater and call a qualified service person. Note: During initial operation, slight smoking could occur due to log curing and heater burning manufacturing residues.
8. To prevent the creation of soot, follow the instructions in Cleaning and Maintenance, page 25 & 26.
9. Before using furniture polish, wax, carpet cleaner or similar products, turn heater off. If heated, the vapors from these products may create a white powder residue within burner box or on adjacent walls or furniture.
10. This heater needs fresh air ventilation to run properly. This heater has an Oxygen Depletion Sensing (ODS) safety shutoff system. The ODS shuts down the heater if not enough fresh air is available. See Air for Combustion and Ventilation, page 9. If heater keeps shutting off, see Troubleshooting, page 27.
11. Do not run heater
 - where flammable liquids or vapors are used or stored.
 - under dusty conditions.
12. Do not use this heater to cook food or burn paper or other objects.
13. Never place any objects in the heater or on logs.
14. Do not use heater if any part has been under water. Immediately call a qualified service technician to inspect the room heater and to replace any part of the control system and any gas control which has been under water.
15. Turn off and unplug heater and let cool before servicing. Only a qualified service person should service and repair heater.
16. Operating heater above elevations of 4,500 feet could cause pilot outage.
17. Do not operate heater if log is broken. Do not operate heater if log is chipped (dime-sized or larger).
18. To prevent performance problems, do not use propane/LP fuel tank of less than 100 lb. capacity.
19. Provide adequate clearances around air openings.

QUALIFIED INSTALLING AGENCY

Only a qualified agency should install and replace gas piping, gas utilization equipment or accessories, and repair and equipment servicing. The term "qualified agency" means any individual, firm, corporation, or company that either in person or through a representative is engaged in and is responsible for:

- a) Installing, testing, or replacing gas piping or
- b) Connecting, installing, testing, repairing, or servicing equipment; that is experienced in such work; that is familiar with all precautions required; and that has complied with all the requirements of the authority having jurisdiction.

PRODUCT IDENTIFICATION

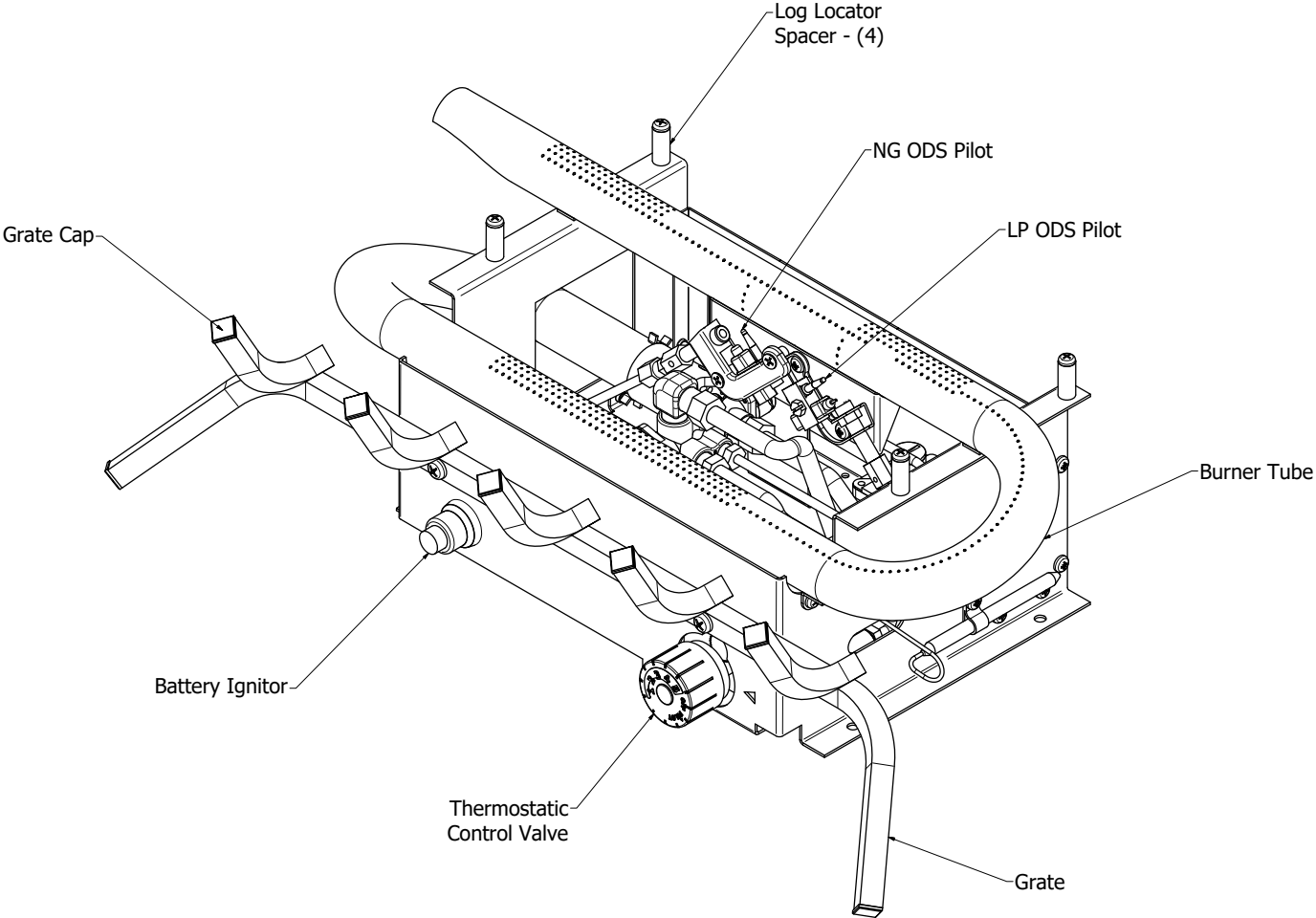

PRODUCT FEATURES

This log set has been tested and approved to ANS Z21.11.2 2013 standard for Unvented Heaters and can be operated with the flue damper closed. State and local codes in some areas prohibit the use of vent-free heaters.

DUAL FUEL CAPABILITY

Your heater is equipped to operate on either propane or natural gas. The heater is shipped from the factory ready for connecting to propane. The heater can easily be changed to natural gas by having your qualified installer follow the instructions on page 16 and the markings on the heater.

SAFETY PILOT

This heater has a pilot with an Oxygen Depletion Sensing (ODS) safety shutoff system. The ODS/pilot shuts off the heater if there is not enough fresh air and cuts off main burner gas in the event of flame out.

ELECTRIC PUSH BUTTON IGNITION SYSTEM

This heater is equipped with an Electronic Push Button control system. This system requires one AAA battery (provided).

THERMOSTAT HEAT CONTROL

The control automatically cycles the burner on and off to maintain a desired room temperature (See page 23).

State of Massachusetts: The installation must be made by a licensed plumber or gas fitter in the Commonwealth of Massachusetts. Sellers of unvented propane or natural gas-fired supplemental room heaters shall provide to each purchaser a copy of 527 CMR 30 upon sale of the unit.

In the State of Massachusetts, unvented propane or natural gas-fired space heaters shall be prohibited in bedrooms and bathrooms.

In the State of Massachusetts the gas cock must be a T-handle type. The State of Massachusetts requires that a flexible appliance connector cannot exceed three feet in length.

LOCAL CODES

Install and use heater with care. Follow all codes. In the absence of local codes, use the latest edition of The National Fuel Gas Code, ANSI Z223.1, also known as NFPA 54*.

*Available from:

American National Standard Institute, Inc.
1430 Broadway
New York, NY 10018

National Fire Protection Association, Inc.
1 Batterymarch Park
Quincy, MA 02269-9101

This heater is designed for vent-free operation. State and local codes in some areas prohibit the use of vent-free heaters.

The installation of appliances designed for manufactured home (U.S. only) or mobile home installation must conform with the Standard CAN/CSA Z240 MH, Mobile Housing, in Canada, or with the Manufactured Home Construction and Safety Standard, Title 24 CFR, Part 3280, in the United States, or when such a standard is not applicable, ANSI/NCSBCS A225.1/NFPA 501A, Manufactured Home Installations Standard.

PREPARING FOR INSTALLATION

WATER VAPOR: A BY-PRODUCT OF UNVENTED ROOM HEATERS

Water vapor is a by-product of gas combustion. An unvented room heater produces approximately one (1) ounce (30 mL) of water for every 1,000 BTUs (.3 kw) of gas input per hour. An unvented room heater is recommended as a supplemental heater (a room) rather than a primary heat source (an entire house). In most supplemental heat applications, the water vapor does not create a problem. In most applications, the water vapor enhances the low humidity atmosphere experienced during cold weather.

The following steps will help ensure that water vapor does not become a problem:

1. Be sure the heater is the proper size for the application, including adequate combustion air and circulation air.
2. If there is high humidity, a dehumidifier may be used to help lower the water vapor content of the air.
3. Do not use an unvented room heater as the primary heat source.

AIR FOR COMBUSTION AND VENTILATION

This heater shall not be installed in a room or space unless the required volume of indoor combustion air is provided by the method described in the *Nation Fuel Gas Code, ANSI Z223.1/NFPA 54*, the *International Fuel Gas Code*, or applicable local codes.

PRODUCING ADEQUATE VENTILATION

All spaces in homes fall into one of the three following ventilation classifications:

1. Unusually Tight Construction
2. Unconfined Space
3. Confined Space

The information on pages 8-10 will help you classify your space and provide adequate ventilation.

Confined and Unconfined Space

A confined space as a space whose volume is less than 50 cu. ft. per 1,000 BTU/hr (4.8 m³ per kw) of the aggregate input rating of all appliances installed in that space and an unconfined space as a space whose volume is not less than 50 cu. ft. per 1,000 BTU/hr (4.8 m³ per kw) of the aggregate input rating of all appliances installed in that space. Rooms connecting directly with the space in which the appliances are installed*, through openings not furnished with doors, are considered a part of the unconfined space.

This heater shall not be installed in a confined space or unusually tight construction unless provisions are provided for adequate combustion and ventilation air.

* Adjoining rooms are connecting only if there are doorless passageways or ventilation grills between them.

Unusually Tight Construction

The air that leaks around doors and windows may provide enough fresh air for combustion and ventilation. However, in buildings of unusually tight construction, you must provide additional fresh air.

Unusually tight construction is defined as construction where:

- a) walls and ceilings exposed to the outside atmosphere have a continuous water vapor retarder with a rating of one perm (6x10⁻¹¹kg per pa-sec-m²) or less with openings gasketed or sealed and
- b) weather stripping has been added on windows that can be opened and on doors and
- c) caulking or sealants are applied to areas such as joints around window and door frames, between sole plates and floors, between wall-ceiling joints, between wall panels, at penetrations for plumbing, electrical, and gas lines, and at other openings.

If your home meets all of the three criteria above, you must provide additional fresh air. See "Ventilation Air From Outdoors" (page 9). If your home does not meet all of the three criteria above, proceed to "Determining Fresh-Air Flow For Heater Location".

PREPARING FOR INSTALLATION

DETERMINING FRESH-AIR FLOW FOR HEATER LOCATION

Determining if You Have a Confined or Unconfined Space

Use this worksheet to determine if you have a confined or unconfined space.

Space: Includes the room in which you will install heater plus any adjoining rooms with doorless passageways or ventilation grills between the rooms.

1. Determine the volume of the space $\text{Length} \times \text{Width} \times \text{Height} = \text{cu. ft. (volume of space)}$
Example: Space size 20 ft. (length) \times 16 ft.(width) \times 8 ft. (ceiling height) = 2560 cu. ft. (volume of space)

If additional ventilation to adjoining room is supplied with grills or openings, add the volume of these rooms to the total volume of the space.

2. Divide the space volume by 50 cu. ft. to determine the maximum BTU/hr the space can support.
 $\text{_____ (volume of space)} \div 50 \text{ cu. ft.} = \text{(Maximum BTU/hr the space can support)}$
Example: 2560 cu. ft. (volume of space) \div 50 cu. ft. = 51.2 or 51,200 (maximum BTU/hr the space can support)

3. Add the BTU/hr of all fuel burning appliances in the space.

Vent-free heater _____ BTU/hr

Gas water heater* _____ BTU/hr

Gas furnace _____ BTU/hr

Vented gas heater _____ BTU/hr Example:

Gas heater logs _____ BTU/hr Gas water heater 30,000 BTU/hr

Other gas appliances*+ _____ BTU/hr Vent-free heater + 26,000 BTU/hr

Total = _____ BTU/hr Total = 56,000 BTU/hr

*Do not include direct-vent gas appliances. Direct-vent draws combustion air from the outdoors and vents to the outdoors.

4. Compare the maximum BTU/hr the space can support with the actual amount of BTU/hr used.

_____ BTU/hr (maximum the space can support)

_____ BTU/hr (actual amount of BTU/hr used).

Example : 51,200 BTU/hr (maximum the space can support) 56,000 BTU/hr (actual amount of BTU/hr used)

The space in the above example is a confined space because the actual BTU/hr used is more than the maximum BTU/hr the space can support.

You must provide additional fresh air. Your options are as follows:

- a) Rework worksheet, adding the space of an adjoining room. If the extra space provides an unconfined space, remove door to adjoining room or add ventilation grills between rooms. See "Ventilation Air From Inside Building," page 9.
- b) Vent room directly to the outdoors. See "Ventilation Air From Outdoors", page 9.
- c) Install a lower BTU/hr heater if lower BTU/hr size makes room unconfined. If the actual BTU/hr used is less than the maximum BTU/hr the space can support, the space is an unconfined space. You will need no additional fresh air ventilation.

PREPARING FOR INSTALLATION

WARNING: If the area in which the heater may be operated does not meet the required volume for indoor combustion air, combustion and ventilation air shall be provided by one of the methods described in the NATIONAL FUEL GAS CODE, ANSI Z223.1/NFPA 54, the INTERNATIONAL FUEL GAS CODE, or applicable local codes.

Ventilation Air From Inside Building

This fresh air would come from adjoining unconfined space. When ventilating to an adjoining unconfined space, you must provide two permanent openings: one within 12 in. of the wall connecting the two spaces (see options 1 and 2, Fig. 1). You can also remove door into adjoining room (see option 3, Fig. 1). Follow the National Fuel Gas Code NFPA 54/ANS Z223.1. Air for Combustion and Ventilation for required size of ventilation grills or ducts.

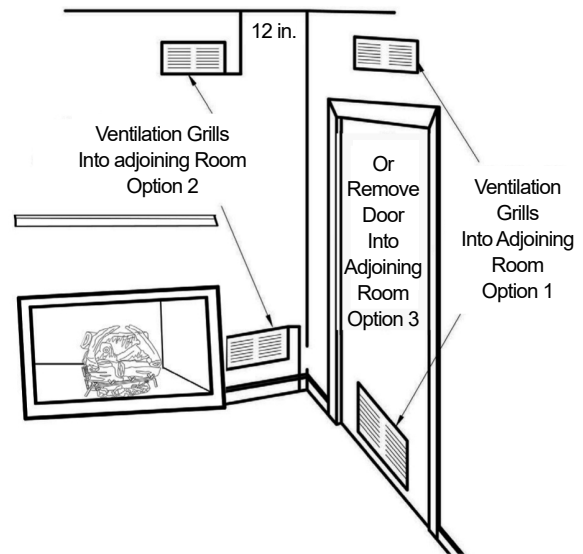

Fig. 1 - Ventilation Air from Inside Building

Ventilation Air From Outdoors

Provide extra fresh air by using ventilation grills or duct. You must provide two permanent openings: one within 12 in. of the ceiling and one within 12 in. of the floor. Connect these items directly to the outdoors or spaces open to the outdoors. These spaces include attics and crawl spaces. Follow the National Fuel Gas Code NFPA 54/ANS Z223.1. Air for Combustion and Ventilation for required size of ventilation grills or ducts.

IMPORTANT: Do not provide openings for inlet or outlet air into attic if attic has a thermostat-controlled power vent. Heated air entering the attic will activate the power vent. Rework worksheet, adding the space of the adjoining unconfined space. The combined spaces must have enough fresh air to supply all appliances in both spaces.

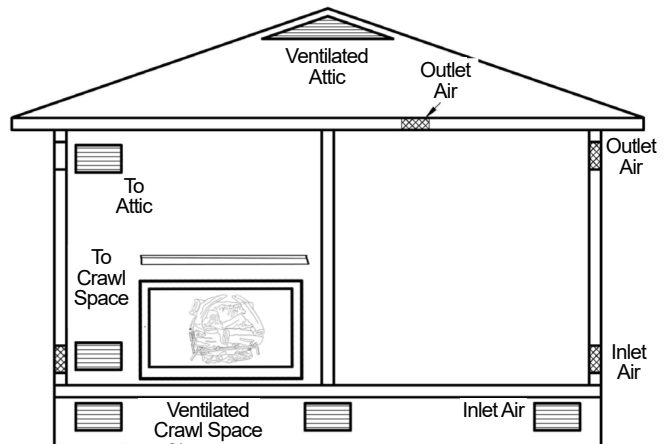

Fig. 2 - Ventilation Air from Outdoors

INSTALLATION

⚠ NOTICE: This heater is intended for use as supplemental heat. Use this heater along with your primary heating system. Do not install this heater as your primary heat source. If you have a central heating system, you may run system's circulating blower while using heater. This will help circulate the heat throughout the house.

⚠ WARNING: A qualified technician must install heater. Follow all local codes.

⚠ WARNING: Never install the heater:

- in a bedroom or bathroom
- in a recreational vehicle
- where curtains, furniture, clothing, or other flammable objects are less than 42 in. from the front, top or sides of the heater.
- in high traffic areas
- in windy or drafty areas

CAUTION: This heater creates warm air currents. These currents move heat to wall surfaces next to heater. Installing heater next to vinyl or cloth wall coverings or operating heater where impurities (such as tobacco smoke, aromatic candles, cleaning fluids, oil or kerosene lamps, etc.) in the air exist, may cause walls to discolor.

⚠ WARNING: Any glass doors shall be fully opened when the appliance is in operation.

⚠ WARNING: Before installing in a solid-fuel burning fireplace, the chimney flue and firebox must be cleaned of soot, creosote, ashes and loose paint by a qualified chimney cleaner.

⚠ WARNING: Do not allow fans to blow directly into the fireplace. Avoid any drafts that alter burner flame patterns.

⚠ WARNING: Do not use a blower insert, heat exchanger insert or other accessory not approved for use with this heater.

IMPORTANT: Vent-free heaters add moisture to the air. Although this is beneficial, installing heater in rooms without enough ventilation air may cause mildew to form from too much moisture. See Air for Combustion and Ventilation, pages 8 through 10.

CHECK GAS TYPE

Be sure your gas supply is right for your heater.

⚠ WARNING: This appliance is designed for installation in only a solid-fuel burning masonry or UL 127 factory-built fireplace or in a listed ventless firebox enclosure. Exception: DO NOT install this appliance in a factory-built fireplace that includes instructions stating it has not been tested or should not be used with unvented gas logs. s worksheet to determine if you have a confined or unconfined space.

⚠ WARNING: Solid-fuels shall not be burned in a fireplace in which an unvented room heater is installed.

⚠ WARNING: Any outside air ducts and/or ash dumps in the fireplace shall be permanently closed at time of appliance installation.

INSTALLATION

CHECK GAS TYPE

Make sure your gas supply is correct for your log set. If supply is not correct, do not install heater. Call dealer where you purchased heater for proper gas log set.

LOG SIZING REQUIREMENTS

Log Size	Minimum Firebox Size			
	Height	Depth	Front Width	Rear Width
18"	24 in.	14 in.	28 in.	20 in.
24"	24 in.	14 in.	32 in.	22 in.

Heater CLEARANCES

- ⚠ CAUTION:** If you install the heater in a home garage
- heater pilot and burner must be at least 18" above floor.
 - locate heater where moving vehicle will not hit it.

For convenience and efficiency, install heater

- where there is easy access for operation, inspection and service
- in coldest part of room
- If this appliance is to be installed directly on carpeting, tile or other combustable material, other than wood flooring, the appliance must be installed on a metal or wood panel extending the full width and depth of the appliance.

Minimum Clearances For Side Combustible Material, Side Wall and Ceiling

A. Clearances from the side of the heater cabinet to any combustible material and wall should follow diagram in Figure 3.

B. Clearances from the top of the heater opening to the ceiling should not be less than 36".

- ⚠ WARNING:** Maintain the minimum clearances. If possible, provide greater clearances from the floor, ceiling, and adjoining wall than required.

Fig. 3

Minimum Fireplace Clearance to Combustible Materials		
Log size	From edge of fireplace opening to side wall	From top of fireplace to ceiling
18 in.	16 in.	42 in.
24in.	16 in.	42 in.

- ⚠ WARNING:** Seal any fresh air vents or ash clean-out doors located on the floor or wall of fire place to prevent drafting caused by pilot outage or sooting. Use a heat-resistant sealant. Do not seal chimney flue damper.

INSTALLATION

MINIMUM NONCOMBUSTIBLE MATERIAL CLEARANCE If Not Using Mantel

You must have noncombustible material(s) above the fireplace opening. Noncombustible materials (such as slate, marble, tile, etc.) must be at least 1/2 in. thick. With sheet metal, you must have noncombustible material behind it, such as a noncombustible fireplace hood accessory. See Fig. 5.

Fig. 4 - Minimum Clearance for Combustible to Wall

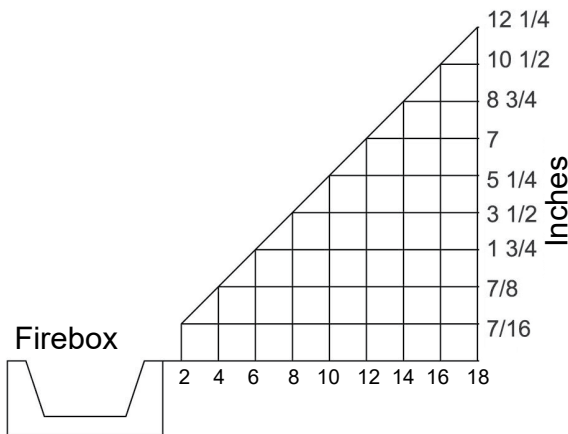
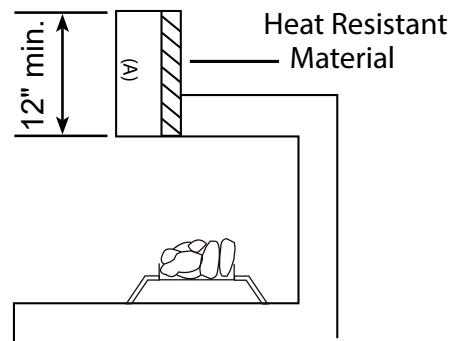

Fig. 5 - Heat resistant material (slate, marble, tile, etc.) above fireplace



If Using Mantel

You must have noncombustible material(s) (such as slate, marble, tile, etc.) at least 1/2 in. thick. With sheet metal, you must have noncombustible material behind it. Noncombustible material must extend at least 12 inches up. See Fig. 7.1 for minimum clearances requirements.

IMPORTANT: Cannot operate if the minimum clearances are not met.

INSTALLATION

MANTEL CLEARANCES

In addition to meeting noncombustible material clearances, you must also meet required clearances between fireplace opening and mantel shelf. If the clearances listed below are not met, you will need to raise the mantel.

Determining Mantel Clearances

If you meet minimum clearance requirements between mantel shelf and top of fireplace opening, your installation (see Fig. 7.1).

Noncombustible Material Distance	Requirements for Safe Installation
8 in. or more	Noncombustible material okay.
Less than 8 in.	Noncombustible material must be extended to at least 8 in. See between 8 in. and 12 in. above.

Determining Minimum Mantel Clearance

Fig. 7.1 - Minimum mantel clearances

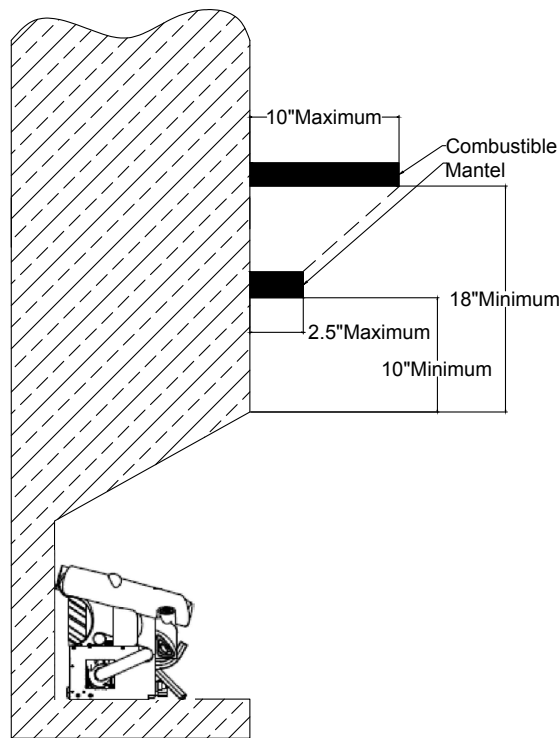

NOTICE: Surface temperature of adjacent walls and mantels become hot during operation. Walls and mantels above the firebox may become too hot to touch. If installed properly, these temperatures meet the requirement of the national product standard. Follow all minimum clearances shown in this manual.

INSTALLATION

FLOOR CLEARANCES

- a) If installing appliance on floor level, you must maintain the minimum distance of 14 in. to combustibles (see Fig. 9).
- b) If combustible materials are less than 14 in. to the fireplace, you must install appliance at least 5 in. above the combustible flooring (see Fig. 8).

Fig. 8 - Minimum fireplace clearances above combustible flooring

Fig. 9 - Minimum fireplace clearances if installed at floor level

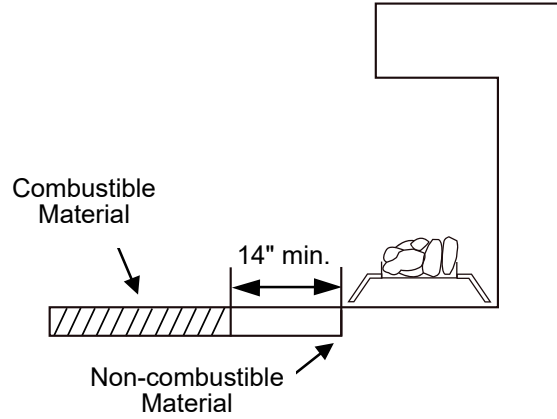
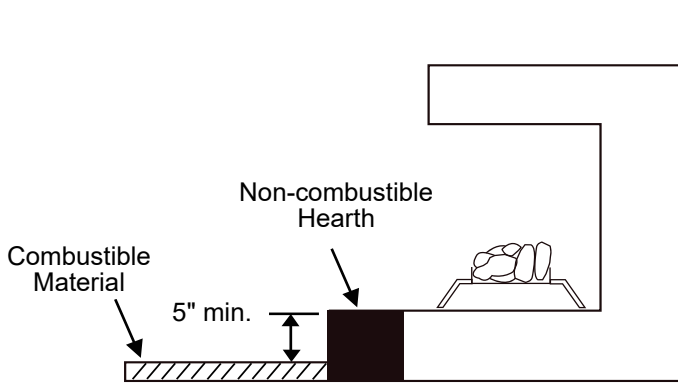

INSTALLATION



WARNING: Failure to position the parts in accordance with these diagrams or failure to use only parts specifically approved with this heater may result in property damage or personal injury.

Before beginning assembly or operation of the product, make sure all parts are present. Compare parts with package contents list. If any part is missing or damaged, do not attempt to assemble, install or operate the product. Contact customer service for replacement parts.

Estimated Assembly Time: 1 to 2 hours

Tools Required for Assembly (Not Included, unless otherwise stated):

Before installing heater, make sure you have the the following:

- Hardware package (provided with heater)
- Approved flexible gas hose if allowed by local codes
- Sealant (resistant to natural or propane/LP gas)
- Electric drill with 3/16- in. drill bit
- Phillips screwdriver
- External regulator (supplied by installer if required)
- Piping (check local codes)
- Equipment shutoff valve
- Test gauge connection
- Sediment trap
- Tee joint
- Pipe wrench
- 3/8" NPT to 1/2" flare fitting
- Allen Wrench

UNPACKING

1. Remove logs, grate, and burner base assembly from carton. NOTE: Do not pick up burner base assembly by burners as this could damage heater. Always handle base assembly by frame.
2. Remove all protective packaging applied to logs and heater for shipment.
3. Check all items for any shipping damage. If damaged, promptly inform dealer where you purchased the heater.

GRATE ASSEMBLY PROCEDURE

1. Position the grate in front of the burner so the 2 legs are pointing downward, the "grate ends" that the logs sit on are pointing upward, and the screw holes line up with the screw holes on the burner unit (See Fig. 11)
2. Hand tighten the grate to the burner with (2) Attachment Screws, each at an equal distance until hand tightening is no longer possible.
3. Finish tightening each Attachment Screw with a screw driver, but make sure not to over tighten.

Fig. 11

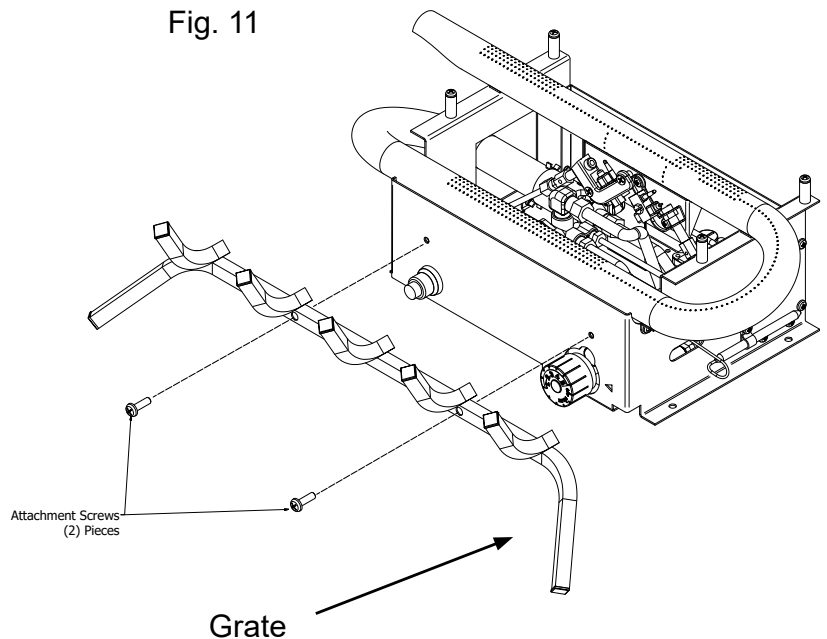

INSTALLATION

GAS SELECTION INSTRUCTIONS

⚠ WARNING: This appliance can be used with propane or natural gas. It is shipped from the factory adjusted for use with propane.

CAUTION: The knob to the gas selection means shall not be accessed or adjusted while the appliance is in operation.

CAUTION: Two gas line installations at the same time are prohibited. The access plate to simple switching means shall not be opened while heater is in operation.

Installation and adjustments shall be made by a qualified technician only.

NOTE: If you are connecting this appliance to propane do not make any adjustments. Proceed to installing the gas line as instructed in the Owner's Manual.

Convert to natural gas:

Step 1 - Remove access panel

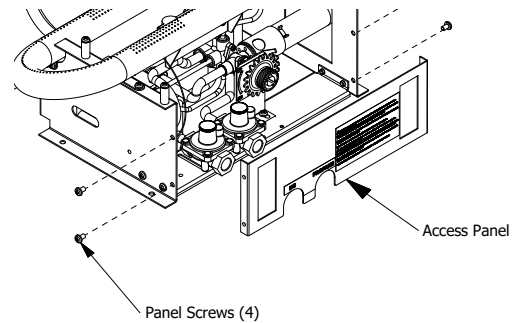

Fig. 12 - Valve Access Panel

Step 2 - Adjust the gas selector valve

Push in on the selector valve Knob and rotate the knob counter-clockwise until it stops. Release the knob (See Fig. 13)

Do not operate the appliance between locked positions.

Step 3 - Replace Access Panel

Reverse step 2 to convert back to propane gas.

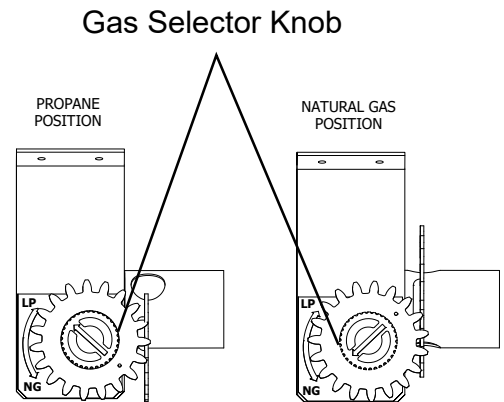

Fig. 13 - Selector Valve

INSTALLATION

CONNECTING TO GAS SUPPLY

⚠ WARNING: A qualified service technician must connect heater to gas supply. Follow all local codes.

CAUTION: Never connect heater directly to the gas supply. This heater requires an external regulator (not supplied). The external regulator between the gas supply and heater must be installed. Gas supplier provides external regulator for natural gas.

⚠ WARNING: Never connect heater to private (non-utility) gas wells. This gas is commonly known as wellhead gas.

The installer must supply an external regulator for liquid propane. The external regulator is provided by the gas supplier for natural gas. The external regulator will reduce incoming gas pressure. You must reduce incoming gas pressure to between 11 and 14 in. of water column for propane and between 6 and 14 in. of water column for natural gas. If you do not reduce incoming gas pressure, heater regulator damage could occur. Install external regulator with the vent pointing down as shown in Fig. 15. Pointing the vent down protects it from freezing rain or sleet.

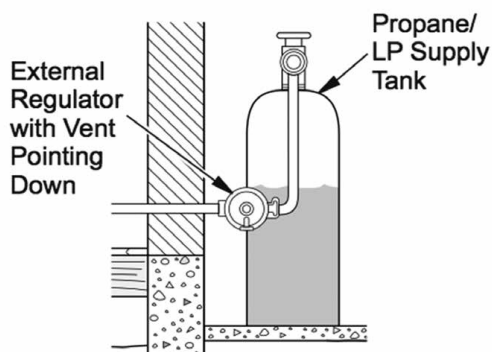

Fig. 14 - Regulator Conversion

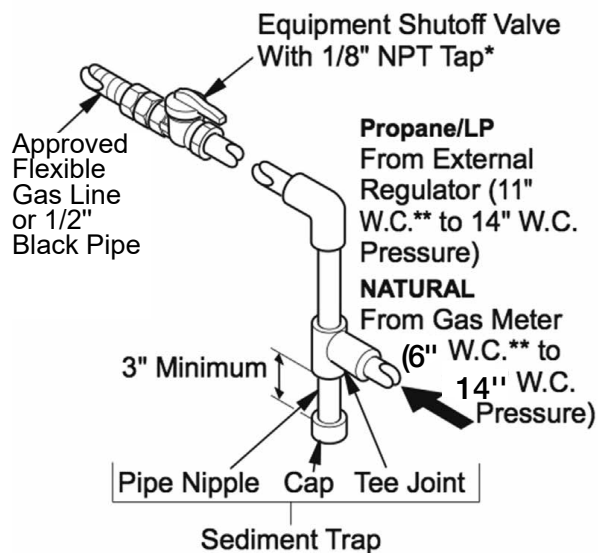

Fig. 15 - Gas Connection

* Purchase the optional equipment shutoff valve from your local Home Center store.

⚠ CAUTION: Use only new black iron or steel pipe. Internally tinned copper tubing may be used in certain areas. Check your local codes. Use pipe of 1/2 in. diameter or greater to allow proper volume gas to heater. If pipe is too small, loss of pressure will occur. Installation must include an equipment shutoff valve, union, and plugged 1/8-in. NPT tap. Locate NPT tap within reach for test gauge hook up. NPT tap must be upstream from heater (See Fig. 15).

IMPORTANT: Install equipment shutoff valve in an accessible location. The equipment shutoff valve is for turning on or shutting off the gas to the appliance. Apply pipe joint sealant lightly to male threads. This will prevent excess sealant from going into pipe. Excess sealant in pipe could result in clogged heater valves.

INSTALLATION

⚠ CAUTION: Use pipe joint sealant that is resistant to gas (PROPANE or NG). We recommend that you install a sediment trap in a supply line. Locate sediment trap where it is within reach for cleaning and not likely to freeze. Install in the piping system between fuel supply and heater. A sediment trap traps moisture and contaminants. This keeps them from going into heater controls. If sediment trap is not installed or is installed incorrectly, heater may not run properly.

⚠ CAUTION: Avoid damage to regulator. Hold gas regulator with wrench when connecting into gas piping and/or fittings. NG Models: 6 in. to 14 in. W.C. Gas supplier provides external regulator for natural gas.

Installation Items Needed (Not Provided)

- 8" Adjustable Wrench
- 8" Pipe Wrench
- 1/2" Flexible Gas Line (24" Min.) or 1/2" Black Pipe
- 90 Deg. 1/2 NPT x 3/8" Flare Fitting or 3/8 NPT x 1/2 NPT Street Elbow
- Sealant (Resistant to Propane (LP) Gas)
- Shut Off Valve
- Allen Wrench

1) A variety of options are possible for routing the Gas Connection Lines depending on where your Gas Supply line is located.

NOTICE: Most building codes do not permit concealed gas connections. Check your local building code prior to using a Flexible Gas Line for this installation.

2) Identify the gas inlet on the Heater that corresponds to the fuel type for your installation. Remove the threaded plug by turning counterclockwise. Install a 90 degree fitting - not included). Be sure to use a gas resistant sealant on the 3/8 NPT fitting. Position the fitting so the inlet line can be attached without binding.

3) Install the Gas Line to the 90 Deg. fitting and attach to the Shut Off Valve.

4) Check all connections for gas leaks.

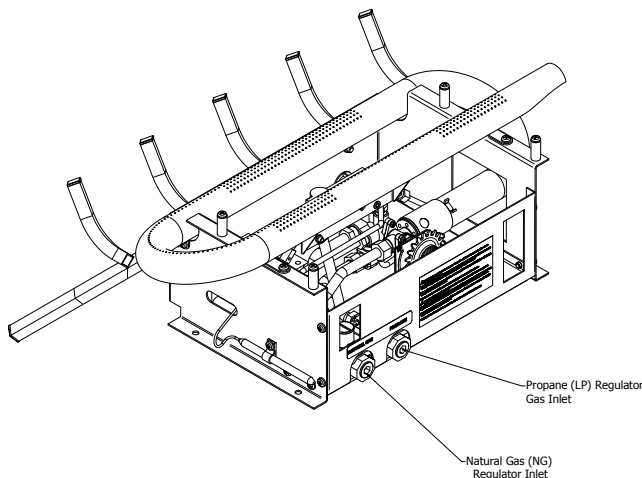

Caution: Two gas line installations at the same time are prohibited.

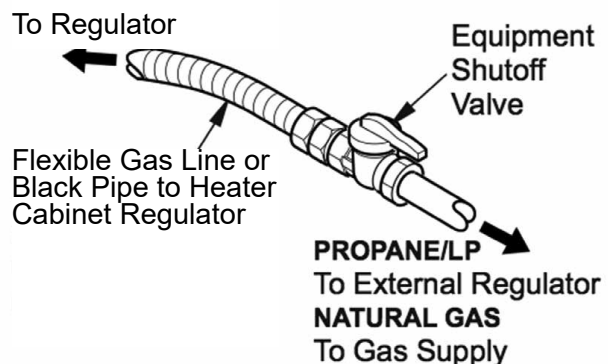

Fig. 16 - Attaching Flexible Gas Line to Equipment Shutoff Valve

INSTALLATION

CHECKING GAS CONNECTIONS

⚠WARNING: Test all gas piping and connections for leaks after installing or servicing. Correct all leaks immediately.

⚠WARNING: Never use an open flame to check for a leak. Apply a mixture of liquid soap and water to all joints. If bubbles form, there may be a leak. Correct all leaks immediately.

Pressure Testing Gas Supply Piping System Test Pressures In Excess Of 1/2 PSIG (3.5kPa)

1. Disconnect heater with its appliance main gas valve (control valve) and equipment shutoff valve from gas supply piping system. Pressures in excess of 1/2 PSIG will damage heater regulator.
2. Cap off open end of gas pipe where equipment shutoff valve was connected.
3. Pressurize supply piping system by either using compressed air or opening gas supply tank valve.
4. Check all joints of gas supply piping system. Apply mixture of liquid soap and water to gas joints. If bubbles form, there may be a leak.
5. Correct all leaks immediately.
6. Reconnect heater and equipment shutoff valve to gas supply. Check reconnected fittings for leaks.

Test Pressures Equal To or Less Than 1/2 PSIG (3.5 kPa)

1. Close equipment shutoff valve (See Fig. 17).
2. Pressure supply piping system by either using compressed air or opening gas supply tank valve.
3. Check all joints from gas meter to equipment shutoff valve (See Fig. 18.1 or 18.2). Apply mixture of liquid soap and water to gas joints. If bubbles form, there may be a leak.
4. Correct all leaks immediately.

Pressure Testing Heater Gas Connections

1. Open equipment shutoff valve (See Fig. 17).
2. Open gas supply tank valve.
3. Make sure control knob of heater is in the OFF position.
4. Check all joints from equipment shutoff valve to control valve (See Fig. 18.1 or 18.2). Apply mixture of liquid soap and water to gas joints. If bubbles form, there may be a leak.
5. Light heater (see Operation, page 23).
Check all other internal joints for leaks.
6. Turn off heater (see "To Turn Off Gas to Appliance," page 23).

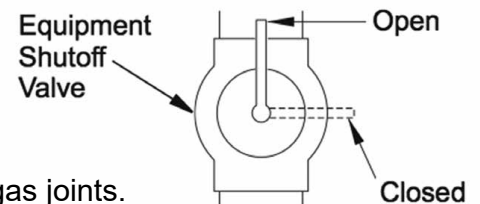
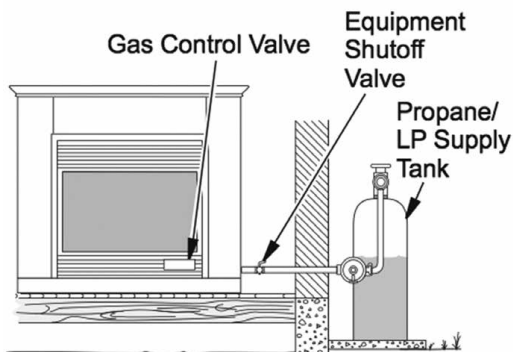
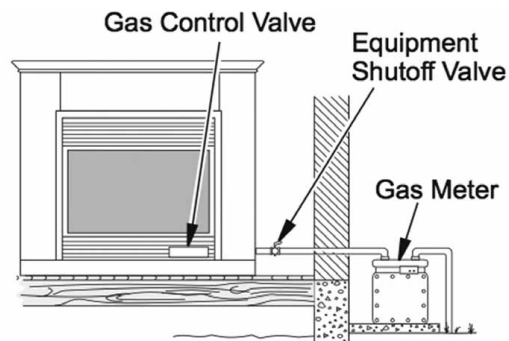

Fig. 17 - Equipment Shutoff Valve



**Fig. 18.1 - Checking Gas Joints
(Propane/LP Only)**



**Fig. 18.2 - Checking Gas Joints
(Natural Gas Only)**

INSTALLATION

BEFORE INSTALLING THE APPLIANCE

- Turn off gas supply to fireplace or firebox.
- Clean fireplace floor and chimney before installing log set. Seal any ash. Clean out doors to protect the unit from down drafts.

MOUNTING PROCEDURE

- Place grate/burner assembly into firebox with the front pan facing forward.
- Drill two (2) 5/32" diameter holes approximately 1" deep.
- Anchor the front pan to the floor using the (2) Concrete Attachment Screws (Not Included) (See Fig. 11.1).
- Proper installation of the grate is essential to prevent any movement of the gas logs and controls during operation.

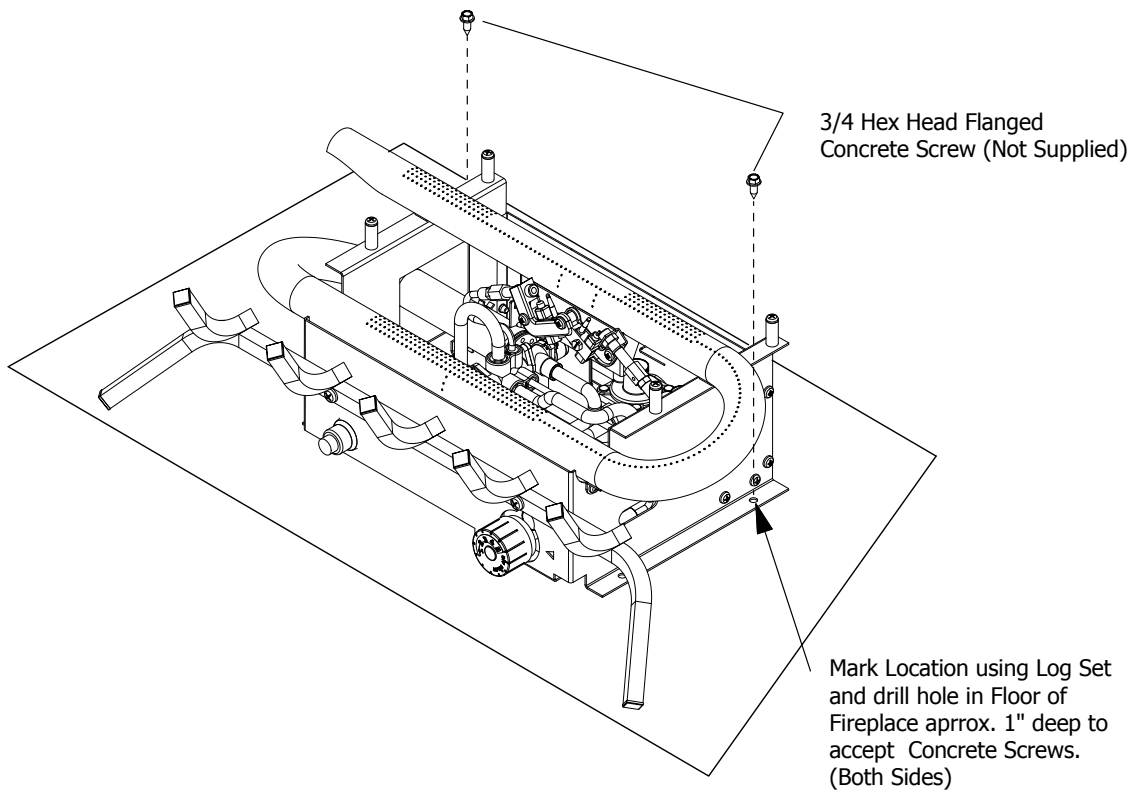

Fig. 11.1

ASSEMBLING LOGS

VFL2-SO18DT / VFL2-EO18DT / VFL2-SO24DT / VFL2-EO24DT

⚠ WARNING: Failure to position the parts in accordance with these diagrams or failure to use only parts specifically approved with this heater may result in property damage or personal injury.

⚠ CAUTION: After installation and periodically thereafter, check to ensure that no yellow flame comes in contact with any log. With the heater set to High, check to see if yellow flames contact any log. If so, reposition logs according to the log installation instructions in this manual. Yellow flames contacting logs will create soot.

It is very important to install the logs exactly as instructed. Do not modify logs; use only logs supplied with heater. Each log is marked with a number, and this number will help you identify each log during installation.

Provided Logs: 6

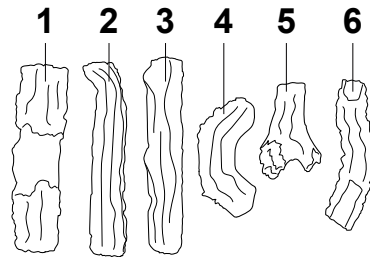
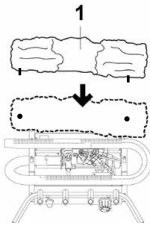
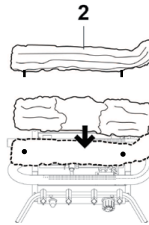

Fig. 19 - Installing Log #1



1. Insert log #1 onto pins in rear grate base.

Fig. 20 - Installing Log #2



2. Insert log #2 onto pins in middle grate base.

Fig. 21 - Installing Log #3

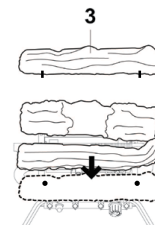

3. Place log #3 onto the front grate. Make sure the recessed areas on the log match up with the grate, and the log is centered on grate.

Fig. 22 - Installing Log #4

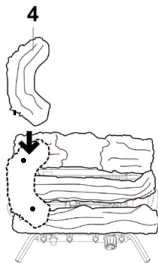

4. Place log #4 so its pin fits into the hole on the top left recessed areas of log #2.

Fig. 23 - Installing Log #5

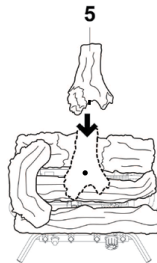

5. Place log #5 so it is resting in the top middle recessed areas of log #1 and its pin fits in the hole on the top of log #2 only (it should NOT be touching log #3), and the front edge does not overhang log #2.

Fig. 24 - Installing Log #6



6. Place log #6 so its pin fits in the hole on the top right recessed areas of log #2.

ASSEMBLING LOGS

VFL2-WW18DT / VFL2-WW24DT

⚠ WARNING: Failure to position the parts in accordance with these diagrams or failure to use only parts specifically approved with this heater may result in property damage or personal injury.

⚠ CAUTION: After installation and periodically thereafter, check to ensure that no yellow flame comes in contact with any log. With the heater set to High, check to see if yellow flames contact any log. If so, reposition logs according to the log installation instructions in this manual. Yellow flames contacting logs will create soot.

It is very important to install the logs exactly as instructed. Do not modify logs; use only logs supplied with heater. Each log is marked with a number, and this number will help you identify each log during installation.

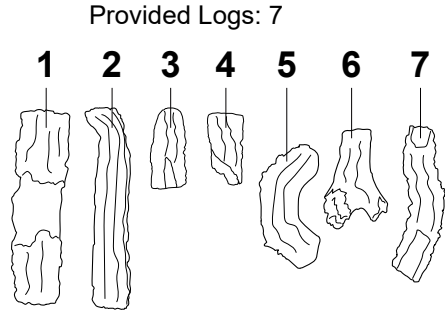
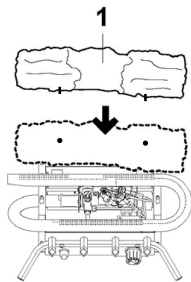
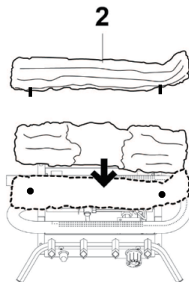

Fig. 19 - Installing Log #1



1. Insert log #1 onto pins in rear grate base.

Fig. 20 - Installing Log #2



2. Insert log #2 onto pins in middle grate base.

Fig. 21 - Installing Log #3 & Log #4

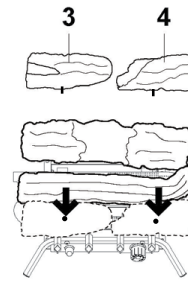

3. Place log #3 & log #4 onto the front grate. Make sure the recessed areas on the logs match up with the grate, and the logs are centered on grate.

Fig. 22 - Installing Log #5

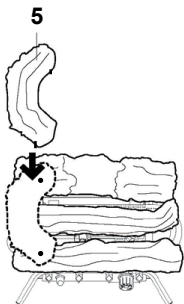

4. Place log #5 so its pin fits into the hole on the top left recessed areas of log #2.

Fig. 23 - Installing Log #6

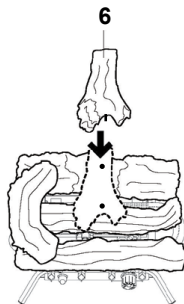

5. Place log #6 so it is resting in the top middle recessed areas of log #1 and its pin fits in the hole on the top of log #2.

Fig. 24 - Installing Log #7

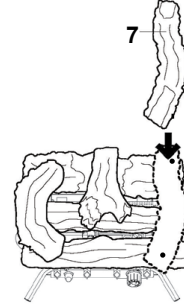

6. Place log #7 so its pin fits in the hole on the top right recessed areas of log #2.