

POLYWOOD®

Intelligent Design™

Model: AD7030

Step 1

Unfold chair assembly

Step 2

Insert (2) 2¼" bolts, washers and locknuts into pre-drill holes
Then insert pins

Step 1

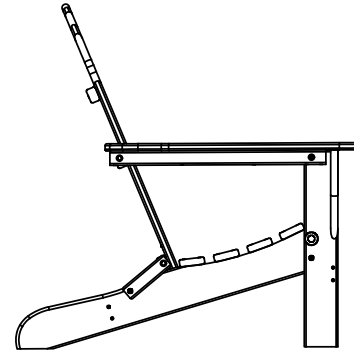

Correct

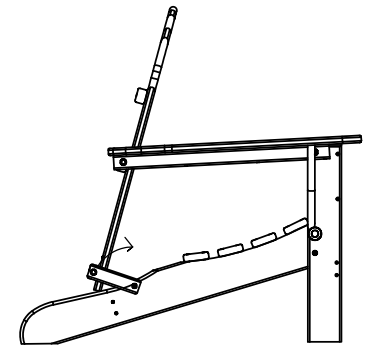

Incorrect



7/16 wrench

4MM HEX KEY, ALLEN, T-HANDLE
(included)

TOOLS NEEDED

Qty.	Description
------	-------------

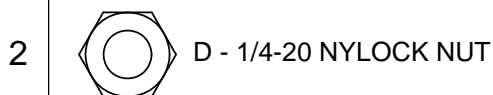
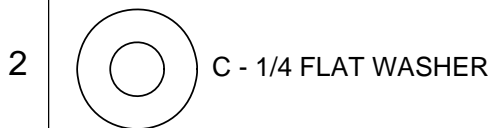
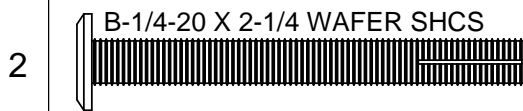
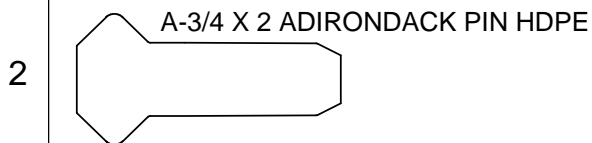

Step 2

