



Item # 741 825  
Model #176-411-5D

## USE AND CARE GUIDE

---

### OAK CLIFF 5-PIECE DINING SET (4 Piece Chairs)

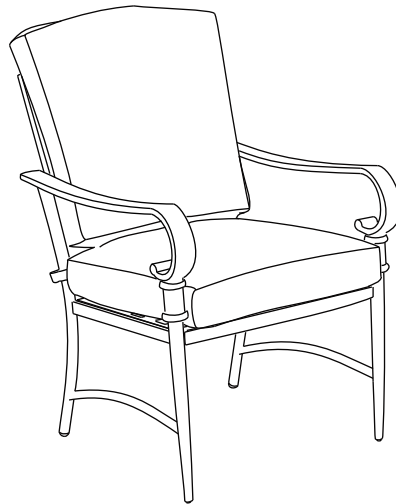

Questions, problems, missing parts? Before returning to the store,  
call Hampton Bay Customer Service  
8.00 a.m. - 7.00 p.m. EST, Monday - Friday,  
9.00 a.m. - 6.00 p.m. EST, Saturday

**1-855-HD-HAMPTON**

**HAMPTONBAY.COM**

---

#### **THANK YOU**

*We appreciate the trust and confidence you have placed in Hampton Bay through the purchase of this 5 piece dining set. We strive to continually create quality products designed to enhance your home. Visit us online to see our full line of products available for your home improvement needs.*

*Thank you for choosing Hampton Bay!*

# Table of Contents

Table of Contents.....	2	Pre-Assembly.....	3
Safety Information.....	2	Planning Assembly.....	3
Warranty.....	2	Hardware Included.....	3
2 Year Frame and Fabric Limited Warranty.....	2	Package Contents.....	4
What Is Covered .. .	2	Assembly .....	5
What Is Not Covered .. .	2		
Care Instructions.....	2		

# Safety Information



**DANGER:** Please keep children out of the assembly area during assembly.



**CAUTION:** Use the chairs on flat ground only.



**IMPORTANT:** Please check the tightness of the bolts periodically.

# Warranty

## 2 YEAR FRAME AND FABRIC LIMITED WARRANTY

### WHAT IS COVERED

We warrant the frame and fabric to be free of manufacturing defects to the original purchaser for two years.

### WHAT IS NOT COVERED

It remains the customer's responsibility for freight and packaging charges to and from our service center. This warranty does not cover commercial use, hardware, acts of nature, fire, freezing and abusive use. In addition, purchased parts are not covered under this warranty. We reserve the right to make substitutions with similar merchandise, if the model in question is no longer in production.

# Care Instructions

Before using, wipe with a clean, dry cloth. Do not use bleach or solvents. Treat frame with one step liquid wax for maximum protection against UV light and salty, damp air. When not in use, store furniture in a cool, dry place. If your set includes cushions, they may be cleaned by hand with a mild solution of soap and water. Rinse cushion thoroughly and allow to drip dry. Do not machine wash or tumble dry, as cushions may shrink. Do not use bleach or solvents on fabrics.

You may contact our customer service department with any questions by phone at 1-855-HD-HAMPTON or visit [www.hamptonbay.com](http://www.hamptonbay.com).

# Pre-Assembly

## PLANNING ASSEMBLY

It will take two people about 30 minutes to complete the assembly process.

## HARDWARE INCLUDED



**NOTE:** Hardware not shown to actual size.



\_\_\_\_\_ AA



\_\_\_\_\_ BB

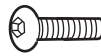

\_\_\_\_\_ CC



\_\_\_\_\_ DD



\_\_\_\_\_ EE

Part	Description	Quantity
AA	Bolt cap (M6)	32
BB	Bolt (M6x30)	16
CC	Bolt (M6x35)	16
DD	Washer	32
EE	Hex wrench	1

# Pre-Assembly (continued)

## PACKAGE CONTENTS

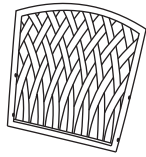

\_\_\_\_\_ A

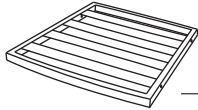

\_\_\_\_\_ B

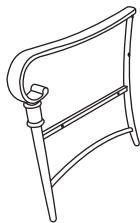

\_\_\_\_\_ C

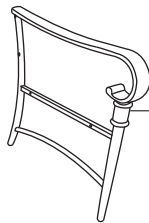

\_\_\_\_\_ D

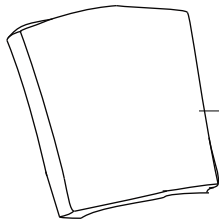

\_\_\_\_\_ 1

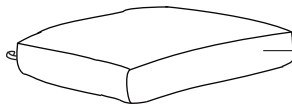

\_\_\_\_\_ 2

Part	Description	Quantity
A	Back panel	4
B	Seat panel	4
C	Right armrest	4
D	Left armrest	4
1	Back cushion	4
2	Seat cushion	4

# Assembly

## 1 Attaching armrests

- Place the right armrest (C) on its side on a flat, smooth surface.
- Align the seat panel (B) to the right armrest (C).



**IMPORTANT:** You will need to align the seat panel (B) to the proper armrest by lining up the bolt holes on each part.

- Secure the seat panel (B) to the right armrest (C) with washers (DD) and bolts (BB) using hex wrench (EE).



**IMPORTANT:** Do not fully tighten bolts until the end of Step 2.

- Repeat the above procedure to attach the left armrest (D).

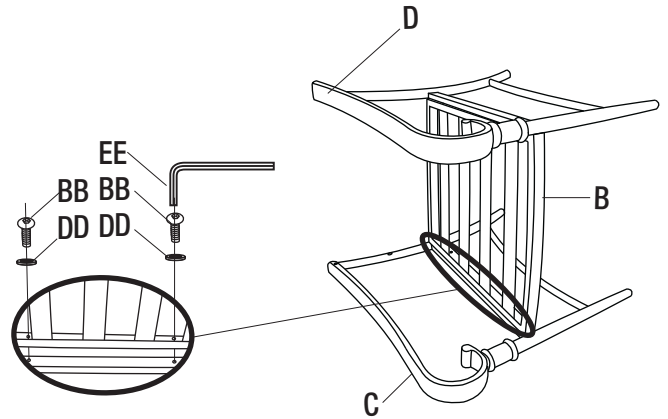

## 2 Attaching the back panel

- Align the back panel (A) to the armrests (C) and (D).
- Attach the armrests (C) and (D) to the back panel (A) with washers (DD) and bolts (CC) using the hex wrench (EE).
- Fully tighten all bolts (CC) and (BB) once all bolts are in place.

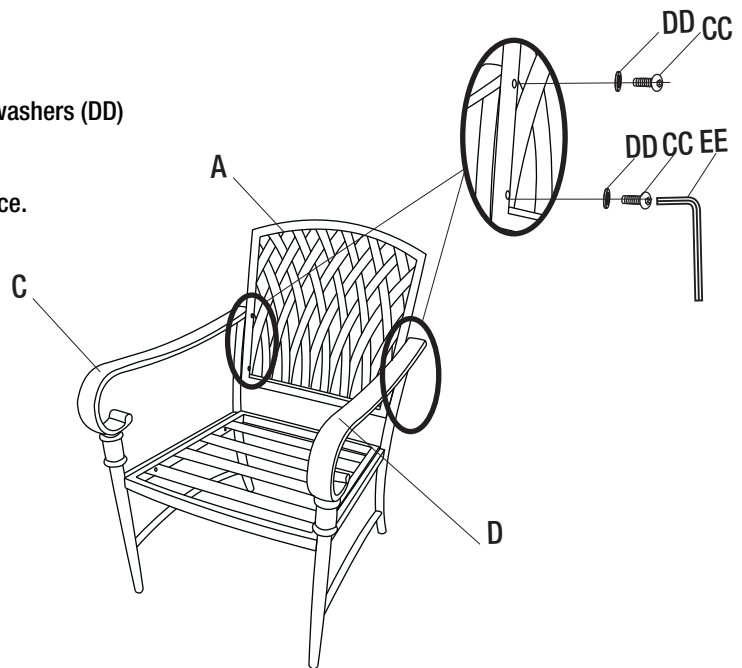

## Assembly (continued)

### 3 Attaching bolt caps

- Cover all bolts (BB) and (CC) with bolt caps (AA).

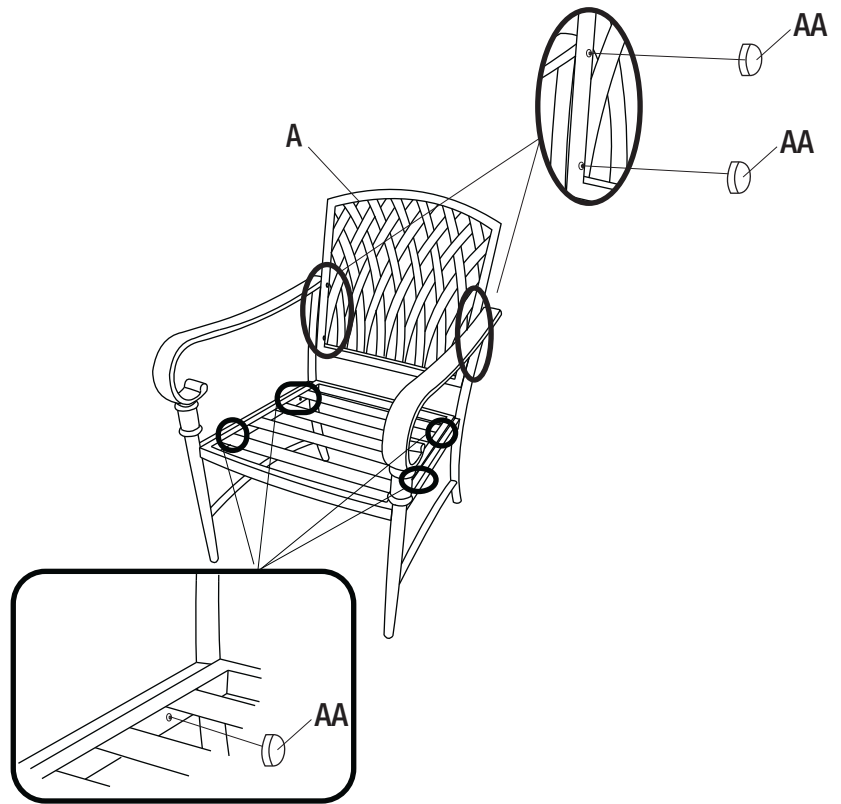

### 4 Stabilizing the dining chair

- Level the dining chair with foot glides at the bottom of front chair legs if necessary.
- Place cushions (1 and 2) on the chair and secure the seat cushion to the frame with hook and loop straps.
- Repeat steps 1 through 4 for the other chairs.

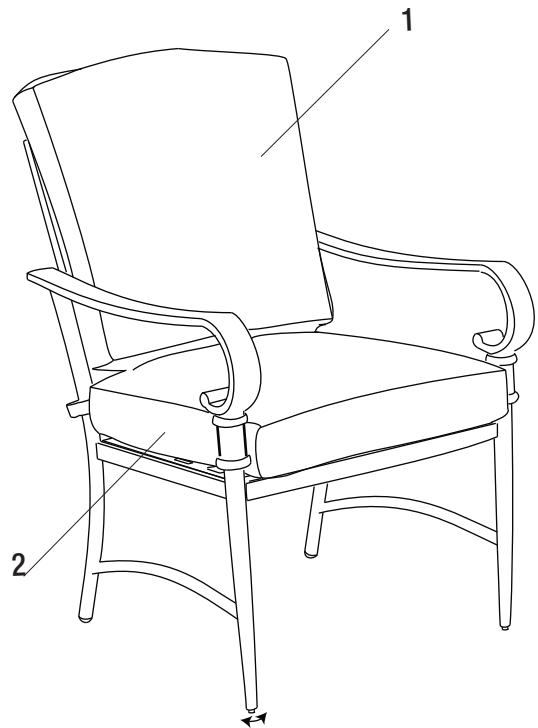



Questions, problems, missing parts? Before returning to the store,  
call Hampton Bay Customer Service  
8.00 a.m. - 7.00 p.m. EST, Monday - Friday,  
9.00 a.m. - 6.00 p.m. EST, Saturday

**1-855-HD-HAMPTON**

**HAMPTONBAY.COM**

Retain this manual for future use.