

DuPont™
StraightFlash™ VF

DuPont™
StraightFlash™

DuPont™
FlexWrap™

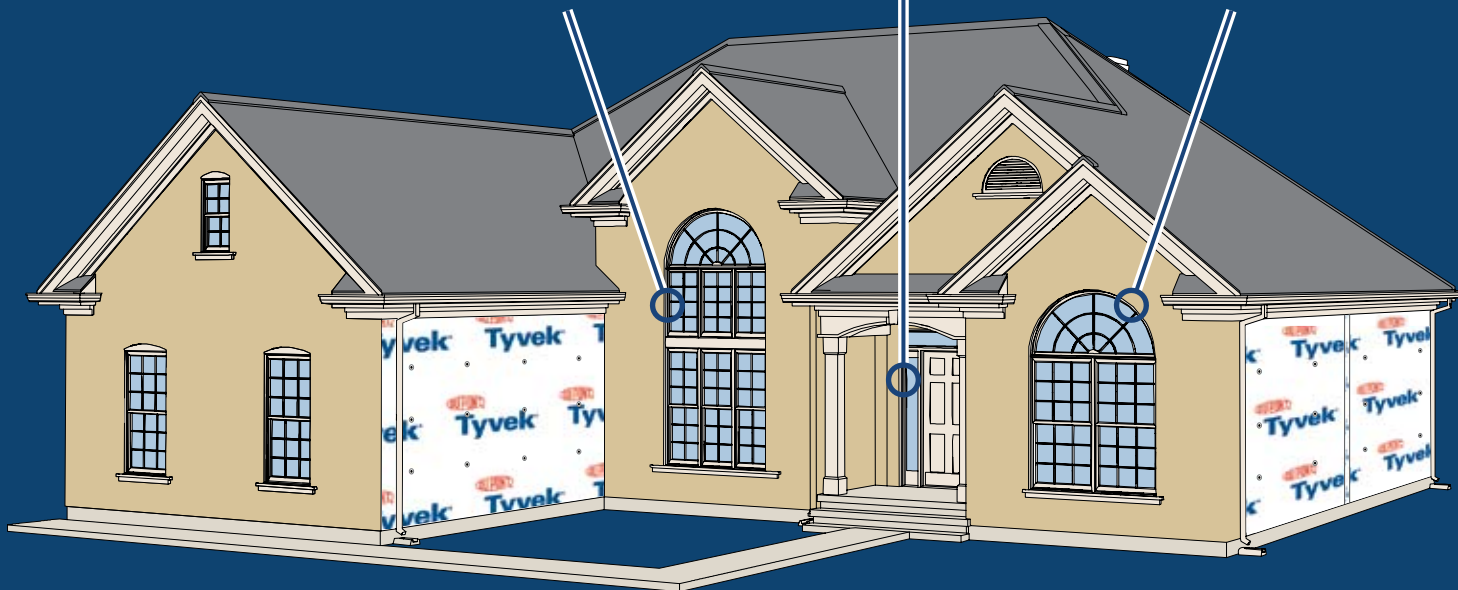

DuPont™ Flashing Systems Installation Guidelines

HELPING YOU GET THE JOB DONE RIGHT

**INTEGRAL FLANGED DOOR AFTER WATER-RESISTIVE
BARRIER (WRB) IS INSTALLED**



The miracles of science™

VERSION 2

Table of Contents

| | |
|--|---|
| Applicable Products | 2 |
| Required Materials | 2 |
| Optional Materials | 2 |
| DuPont Recommended Primers..... | 2 |
| DuPont Recommended Low Expansion Foams..... | 3 |
| DuPont Recommended Fasteners | 3 |
| General Instructions | 3 |
| Installation Instructions Integral Flanged Door AFTER Water-Resistive Barrier (WRB) is Installed..... | 4 |

Applicable Products

DuPont™ Flashing Systems Products

| PRODUCT | DIMENSIONS | AREA |
|---------------------------|---------------|-------------|
| DuPont™ FlexWrap™ | 7 in x 75 ft | 43.7 sq ft |
| | 9 in x 75 ft | 56.2 sq ft |
| | 9 in x 250 ft | 187.5 sq ft |
| DuPont™ StraightFlash™ VF | 6 in x 125 ft | 62.5 sq ft |
| DuPont™ StraightFlash™ | 4 in x 150 ft | 50 sq ft |
| | 9 in x 125 ft | 93.75 sq ft |

Required Materials

- DuPont™ Flashing Systems
- DuPont™ Tyvek® Tape
- DuPont™ Weatherization Sealant
- DuPont™ Tyvek® Wrap Caps or other DuPont Recommended Fasteners
- Brushes for Surface Preparation

Optional Materials

- Backer rod
- J -roller

DuPont Recommended Primers*

| MANUFACTURER | PRODUCT NAME |
|--------------|-----------------------------|
| 3M | Hi-Strength 90 |
| Denso | Butyl Primer (spray or can) |
| Henkel | SIA 655 |
| Henkel | Permagrip® 105™ |
| ITW TACC | STA'PUT SPH |

* Apply per manufacturers' guidelines. DuPont assumes no liability in use of recommended products; installers need to evaluate suitability of recommended products in their end-use applications.

DuPont Recommended Low Expansion Foams*

| MANUFACTURER | PRODUCT NAME |
|--------------|--------------------------|
| Selena | Tytan™ Window & Door Pro |
| Todol | E-Z Flo |

* Apply per manufacturers' guidelines. DuPont assumes no liability in use of recommended products; installers need to evaluate suitability of recommended products in their end-use applications.

DuPont Recommended Fasteners*

| MANUFACTURER | PRODUCT NAME |
|--------------|--|
| DuPont | DuPont™ Tyvek® Wrap Cap nails |
| DuPont | DuPont™ Tyvek® Wrap Cap screws |
| DuPont | DuPont™ Tyvek® Wrap Cap staples (for Stinger™) |
| Several | 1.0 inch minimum crown staples** |

* Apply per manufacturers' guidelines. DuPont assumes no liability in use of recommended products; installers need to evaluate suitability of recommended products in their end-use applications.

** Except when installing DuPont™ Tyvek® WRBs over foam sheathing.

General Instructions

DuPont™ Flashing Systems products should be installed on clean, dry surfaces that are free of frost. Wipe surfaces to remove moisture, dirt, grease and other debris that could interfere with adhesion.

Apply pressure along entire surface for a good bond using a J-roller or firm hand pressure.

Remove all wrinkles and bubbles by smoothing surface and repositioning as necessary.

When flashing the sill area for windows and doors, DuPont recommends the use of 7" wide DuPont™ FlexWrap™ for 2" x 4" framing and 9" wide DuPont™ Flexwrap™ for 2" x 6" framing. When rigid back dams are required or desired, an option would be to use a ¾" corner guard (back dam) cut to the length of the sill and nail into place on the interior edge of the sill prior to installation of DuPont™ FlexWrap™. Then install DuPont™ FlexWrap™ over sill and corner guard back dam.

Door and window rough sill framing must be level or slightly sloped to the exterior to ensure proper drainage to the exterior. DuPont recommends the use of the SureSill™ Sloped Sill Pan™, manufactured by SureSill, Ltd, on all exterior doors and in certain applications on windows. This best practice ensures continuous support with positive slope to the exterior. Please contact your local DuPont™ Tyvek™ Specialist for additional information and installation instructions.

DO NOT STRETCH DuPont™ FlexWrap™ when installing along sills or jambs. DuPont™ FlexWrap™ is only intended to be stretched when covering corners or curved sections.

DuPont™ Flashing Systems products perform best when installed at temperatures above 25°F (-4°C).

Avoid placing DuPont™ Tyvek® Wrap Caps where flashing will be installed; however, DuPont™ Tyvek® Wrap Caps can be applied over the flashing.

Where buildings could be exposed to extreme weather conditions (ie. sustained wind-driven rain above 50mph), install a high pressure skirt to help prevent water intrusion at the sill.

Priming is generally not required for adhering DuPont™ Flashing Systems products to most common building materials. However, adverse weather conditions or cold temperatures may require use of a primer to promote adhesion. Additionally, concrete, masonry, and fiber-faced exterior gypsum board require the use of approved primers. For primer recommendations, see page 2.

For additional guidelines and suggested sealants, please call 1-800-44-Tyvek (800-448-9835), visit our website at www.Construction.Tyvek.com, or consult your local DuPont™ Tyvek® Specialist..

Integral Flanged Door AFTER Water-Resistive Barrier (WRB) is Installed

Method applies to following products:

- DuPont™ StraightFlash™
- DuPont™ FlexWrap™

STEP 1

Prepare WRB for door installation:

- Make an "I-Cut" (Standard I-Cut) in the WRB (modified I-Cut is also accepted). For an "I-Cut", begin with a horizontal cut across the bottom and the top of the door frame. From the center, cut straight down to the sill.
- Cut two 45 degree slits a minimum of 8" from the corner of the header to create a flap above the rough opening to expose sheathing or framing members to allow head flashing installation (see step 8).
- Flip head flap up and temporarily secure with DuPont™ Tyvek® Tape. Some doors and flashing widths may require longer slits.
- Fold side flaps into rough opening, cut excess flaps, and secure.

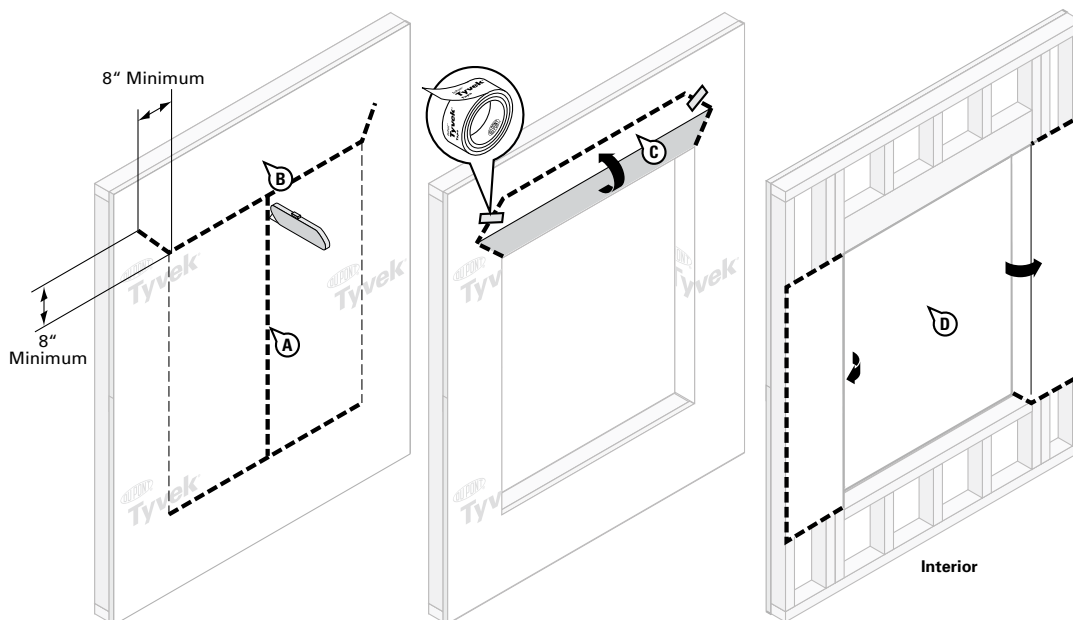

STEP 2

Preparation of sill flashing:

- Cut DuPont™ FlexWrap™ at least 12" longer than width of the sill (S).
- DuPont™ FlexWrap™ has perforated release paper to help with the formation of the back dam. To ensure that the perforation tears cleanly, fold the perforation 180° and crease the flashing.
- Remove the two widest pieces of release paper leaving the narrowest release paper on the flashing. When the finished floor is applied, the release paper can be removed and the back dam can be completed.

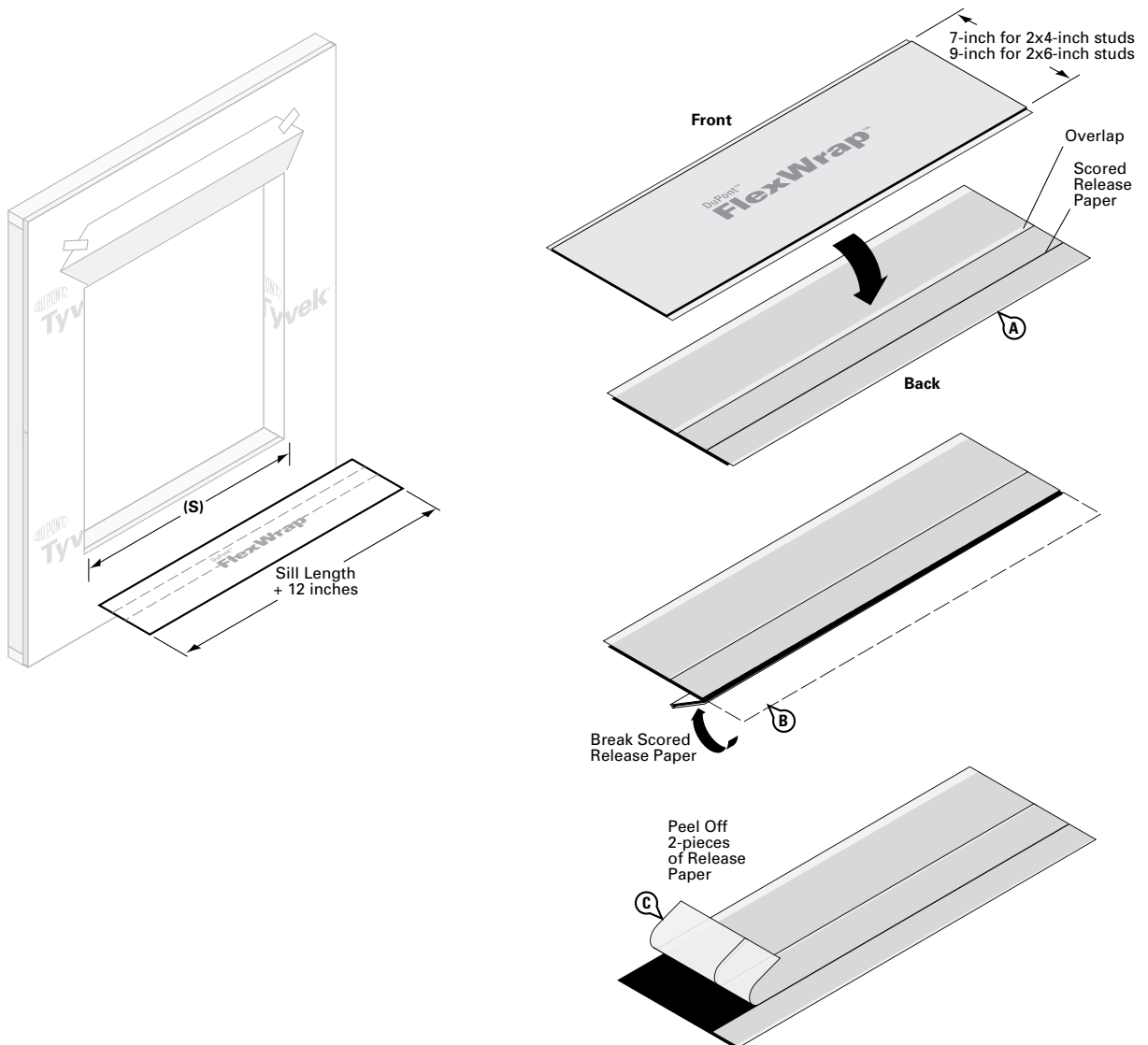

DuPont™ Flashing Systems Installation Guidelines

STEP 3

A. Install the sill flashing as indicated leaving the 1" of DuPont™ FlexWrap™ with release paper extending it past the door threshold on the inside. When the 1" of release paper is removed, there should be 3/4" of flashing to form the back dam.

Optional: Some flooring cannot accommodate a back dam. In that case, fold the 1" back dam on top of DuPont™ FlexWrap™ in the sill. Door will be installed on top of the 1" fold to create a back dam.

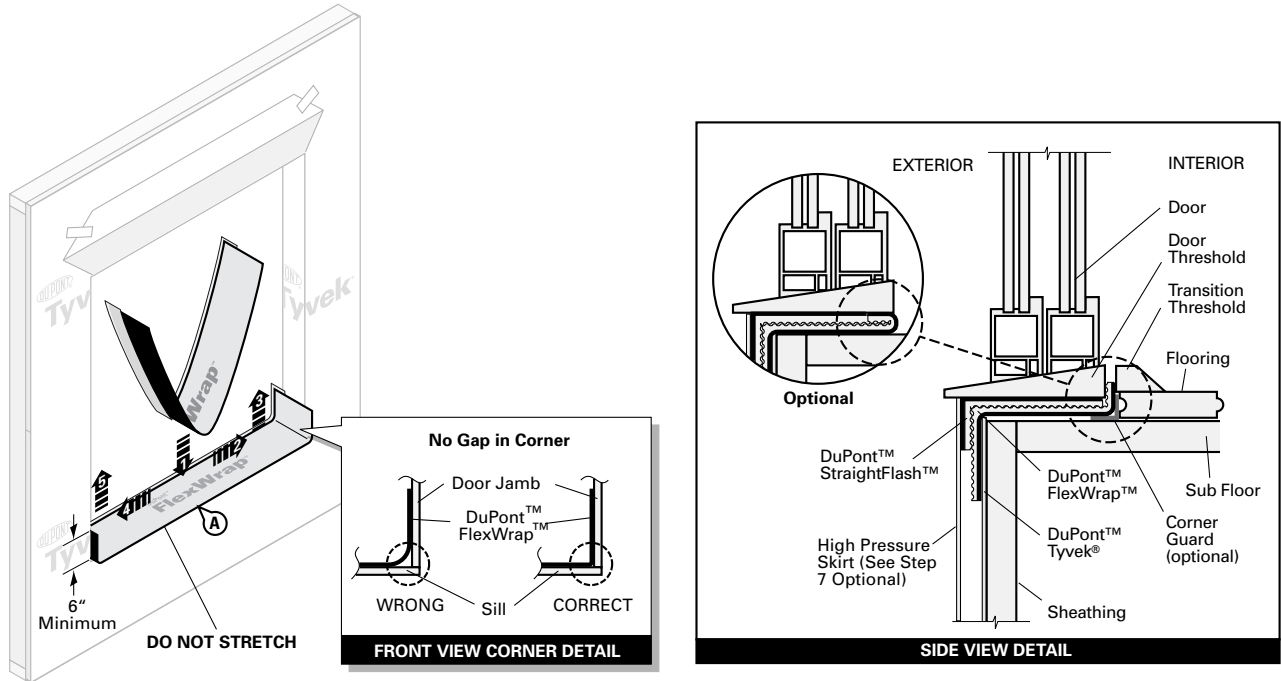

STEP 4

A. Fan out DuPont™ FlexWrap™ at bottom corners onto face of wall. Coverage of DuPont™ FlexWrap™ should be 2" to 3" onto the face of the wall.

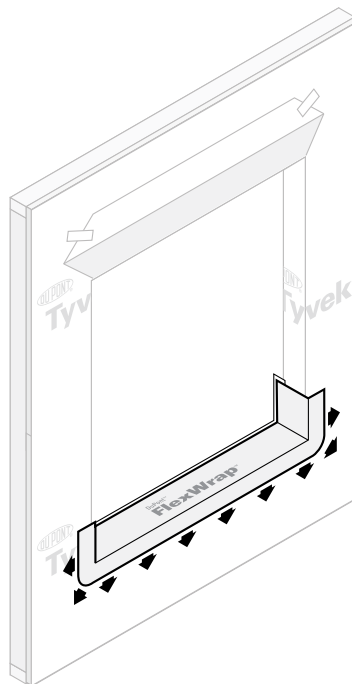

STEP 5

- A. **SECURE EDGES OF DUPONT™ FLEXWRAP™ WITH DUPONT RECOMMENDED FASTENERS** along the bottom outer edge of the DuPont™ FlexWrap™ at fanned corners.

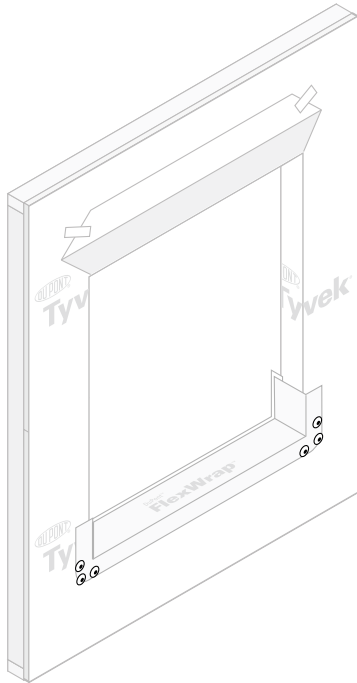

STEP 6

- A. Apply continuous bead of DuPont™ Weatherization Sealant at the window head and jambs to wall or back side of window mounting flange. **DO NOT APPLY A CONTINUOUS BEAD OF SEALANT ACROSS BOTTOM SILL FLANGE** to allow for drainage.

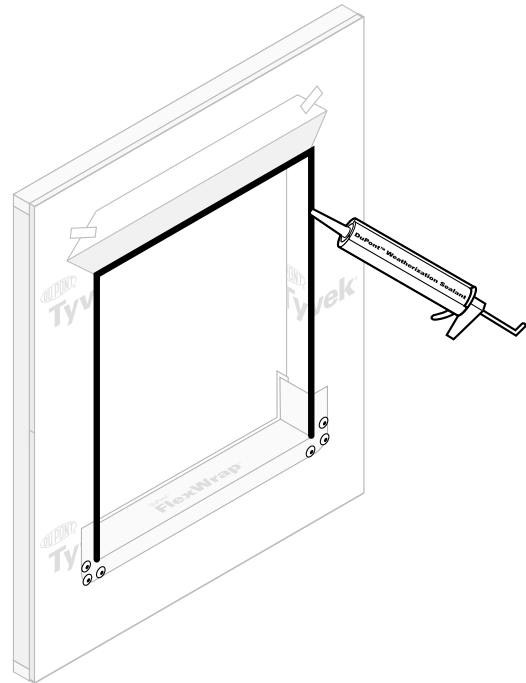

STEP 7 (OPTIONAL)

For extreme weather conditions, see General Instructions.

- A. Create the high pressure skirt by cutting a piece of DuPont™ Tyvek® 1" wider than the width of door opening and approximately 10 inches in depth.
- B. Cut a 4" piece of DuPont™ StraightFlash™ to the same width as the skirt. Remove two pieces of release paper and adhere to the DuPont™ Tyvek®.
- C. Remove the last piece of release paper and attach the skirt to the underside of the door. This skirt may be made with either DuPont™ StraightFlash™ or DuPont™ StraightFlash™ VF.

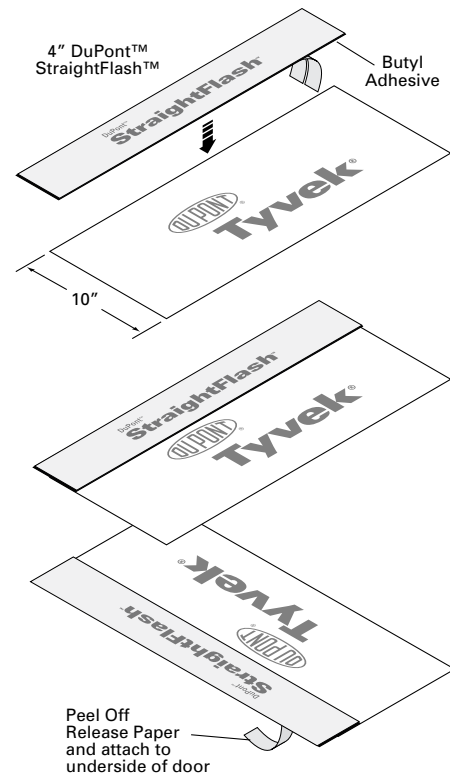

DuPont™ Flashing Systems Installation Guidelines

STEP 8

- A. Install door according to manufacturer's instructions.
- B. (Optional)—see General Instructions. Adhere high pressure skirt to the bottom threshold of the door.
- C. Cut two pieces of DuPont™ StraightFlash™ or DuPont™ FlexWrap™ for jamb flashing extending 1" above door head flange and below bottom edge of sill flashing. Remove release paper and press tightly along sides of door frame.
- D. Cut a piece of DuPont™ StraightFlash™ or DuPont™ FlexWrap™ for head flashing, which extends beyond outer edges of jamb flashings. Remove release paper and install completely covering mounting flange and adhering to exposed sheathing or framing members (see D).

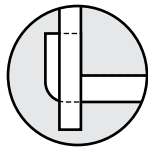
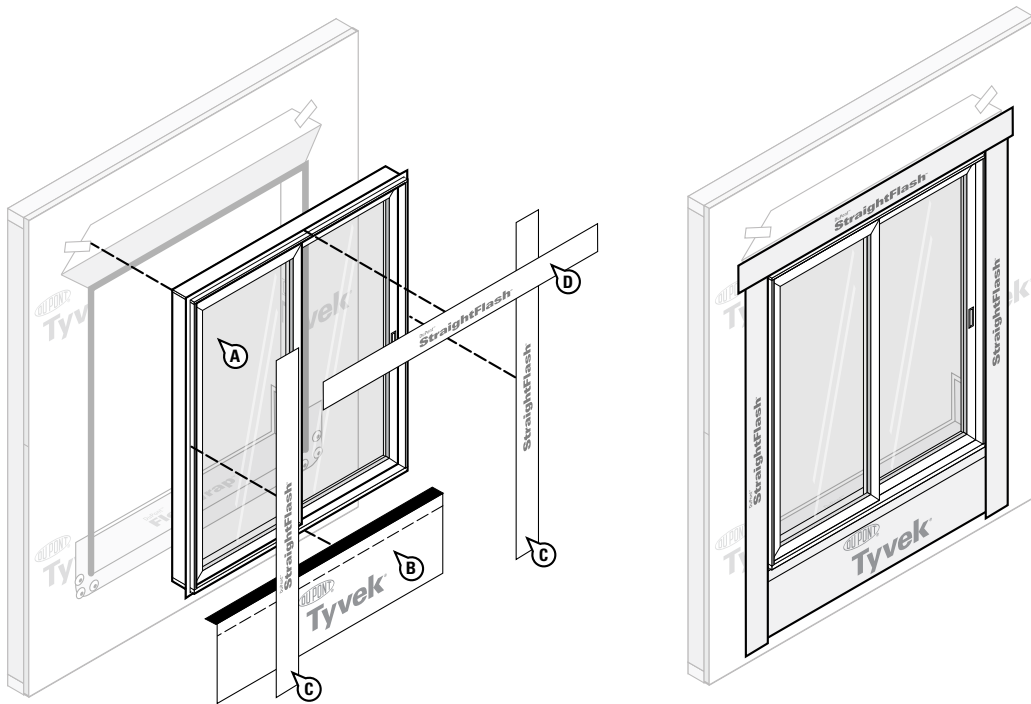

INCORRECT
DuPont™ FlexWrap™
reverse flashed

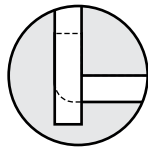

INCORRECT
DuPont™ StraightFlash™
flush with DuPont™
FlexWrap™

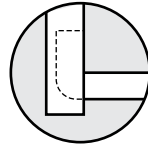

CORRECT
DuPont™ StraightFlash™
overlaps DuPont™
FlexWrap™

NOTE: Do not reverse shingle. DuPont™ StraightFlash™ must overlap DuPont™ FlexWrap™ and adhere to the substrate.

STEP 9

- A. Flip down upper flap of WRB so it lays flat across head flashing.
- B. Tape down diagonal seams of WRB.
- C. Tape edge of DuPont™ Tyvek® to edge of door at jambs. At the head, continuous tape seams as shown with DuPont™ Tyvek® Tape; if an air barrier is not required or if additional drainage is desired, then skip-tape at the head. **DO NOT TAPE** at bottom of door.

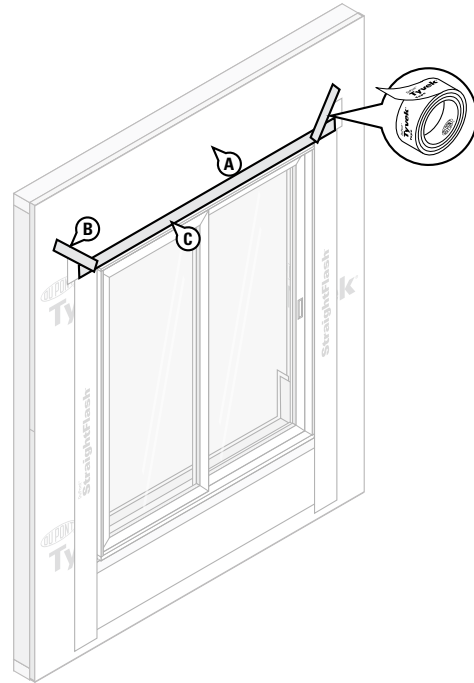

STEP 10

Final Step

- A. When the interior flooring is ready to install, remove release paper and use option one or two (shown below) to form back dam.
- B. Tool sealant around the door opening at the interior, using DuPont™ Weatherization Sealant or DuPont Recommended Low Expansion Foam (and backer rod as necessary).

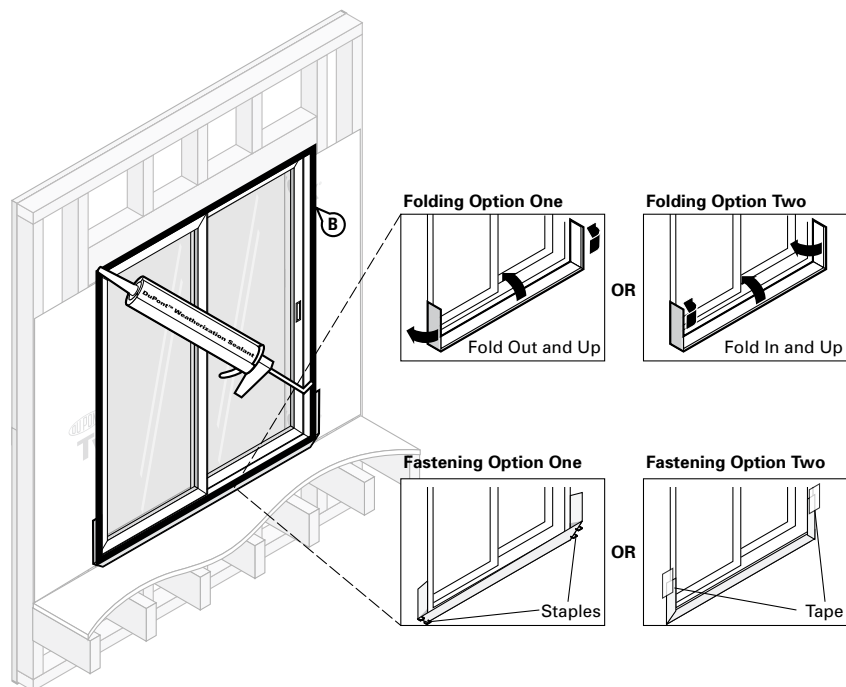

Technical Specifications

DuPont™ Tyvek® WRBs used in construction products is made from 100% flash spunbonded high density polyethylene fibers which have been bonded together by heat and pressure, without binders or fillers, into a tough, durable sheet structure. Additives have been incorporated into the polyethylene to provide ultraviolet light resistance. DuPont requires that DuPont™ Tyvek® WRBs be covered within four months (120 days) of installation.

DuPont™ Flashing Systems products are made from a synthetic rubber adhesive and a laminate of polyethylene film, elastic fiber, synthetic rubber adhesive, polyurethane adhesive, and a top sheet of flash spunbonded high density polyethylene fibers. Additives have been incorporated into these materials to provide ultraviolet light resistance. DuPont requires that DuPont™ Flashing Systems products be covered within four months (120 days) of installation.

Warning

DuPont™ Tyvek® WRBs are slippery and should not be used in any application where it will be walked on. In addition, because it is slippery, DuPont recommends using kickjacks or scaffolding for exterior work above the first floor. If ladders must be used, extra caution must be taken to use them safely by following the requirements set forth in ANSI Standards 14.1, 14.2 and 14.5 for ladders made of wood, aluminum, and fiberglass, respectively. DuPont™ Tyvek® is combustible and should be protected from a flame and other high heat sources. DuPont™ Tyvek® will melt at 275°F (135°C) and if the temperature of DuPont™ Tyvek® reaches 750°F (400°C), it will burn and the fire may spread and fall away from the point of ignition. For more information, call 1-800-44-Tyvek.

DuPont™ Flashing Systems products and their release paper are slippery and should not be walked on. Remove release paper from work area immediately. DuPont™ Flashing Systems products will melt at temperatures greater than 250°F (121°C). DuPont™ Flashing Systems products are combustible and should be protected from flame and other high heat sources. DuPont™ Flashing Systems products will not support combustion if the heat source is removed. However, if burning occurs, ignited droplets may fall away from the point of ignition. For more information, call 1-800-44-Tyvek.

DuPont™ Weatherization Sealant is irritating to skin, eyes, and respiratory tract. For proper usage, follow directions stated on the product label. For health information, refer to the Material Safety Data Sheet or call Chemtrec at 1-800-424-9300.

Note

When installed in conjunction with other building materials, DuPont™ Flashing Systems products must be properly shingled with these materials, such that water is diverted to the exterior of the wall system. DuPont™ Tyvek® products are WRBs and not the primary water barrier (the outer facade is the primary barrier). You must follow façade manufacturer's installation and maintenance requirements for all façade systems in order to maintain water holdout properties and ensure performance of DuPont™ Tyvek®. Use of additives, coatings or cleansers on or in the façade system may impact the performance of DuPont™ Tyvek® water-resistive barriers. DuPont™ Tyvek® Weatherization Systems products are to be used as outlined in this installation guideline. DuPont™ Flashing Systems products should only be used to seal penetrations and flash openings in houses or buildings. DuPont™ Flashing Systems products are not to be used in roofing applications. For superior protection against bulk water penetration, DuPont suggests a system combining a quality exterior facade, a good secondary WRB, an exterior sheathing, appropriate flashing materials and details. In addition, DuPont suggests to use high quality windows and doors with particular attention to proper installation of each component. In a system where no exterior sheathing is used and DuPont™ Tyvek® is installed directly over the wall studs, exterior facade materials should be selected to ensure maximum protection against water intrusion. Careful workmanship and proper installation of each component is very important.

DuPont believes this information to be reliable and accurate. The information may be subject to revision as additional experience and knowledge is gained. It is the user's responsibility to determine the proper construction materials needed.

For complete warranty information, please call 1-800-44-Tyvek. To submit a warranty claim, please contact DuPont at www.Construction.Tyvek.com or call 1-800-44-Tyvek. Warranty coverage requires submission of proof of purchase of the DuPont™ Tyvek® at issue.

This information is not intended to be used by others for advertising, promotion or other publication for commercial purposes.

For more information about DuPont™ Tyvek® Weatherization Systems, please call 1-800-44-Tyvek or visit us at www.Construction.Tyvek.com



The miracles of science™

DuPont™
Flashing Systems