

Single Pole and 3-Way Wide View Motion Activated Light Control

Cat. No. IPS15, IPV15 - INDOOR USE ONLY

120VAC, 60Hz - Incandescent: 1800W-15A - Fluorescent: 1800VA-15A - Supplemental: 1/2HP - LED & CFL: 600W

Compatible with incandescent lamps, magnetic fluorescent ballasts, fans, CFL and LED lamps.

INSTALLATION INSTRUCTIONS

WARNINGS AND CAUTIONS:

- **TO AVOID FIRE, SHOCK, OR DEATH; TURN OFF POWER AT CIRCUIT BREAKER OR FUSE AND TEST THAT THE POWER IS OFF BEFORE WIRING!**
- To be installed and/or used in accordance with electrical codes and regulations.
- To avoid overheating and possible damage to this device and other equipment, **DO NOT** install to control a receptacle.
- **DO NOT** control a load in excess of specified ratings or you may damage property, or cause injury or death.
- If you are not sure about any part of these instructions, consult an electrician.

WARNINGS AND CAUTIONS:

- When using in a 3-way or more application use appropriate matching or coordinating switch remote(s).
- Clean outer surface gently with damp cloth only. **DO NOT** use soaps or cleaning liquids.
- No user serviceable components. **DO NOT** attempt to service or repair.
- Use this device **WITH COPPER OR COPPER CLAD WIRE ONLY.**

PK-93977-10-00-2A

TOOLS NEEDED TO INSTALL YOUR DEVICE

- Slotted/Phillips Screwdriver
- Electrical Tape
- Pliers
- Pencil
- Cutters
- Ruler

CHANGING THE COLOR OF YOUR DEVICE

Your device may include color options. To change color of the face proceed as follows:

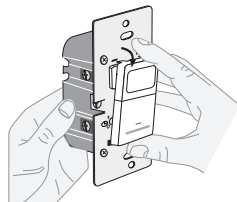

Push down tabs per diagram, one at a time and rotate forward to release

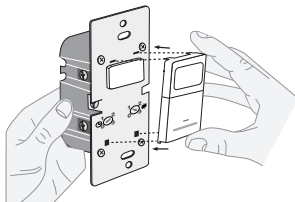

Attach new face by inserting bottom hinge tabs, then pivot and snap the color kit to attach

FEATURES

- Cat. No. IPS15 and IPV15 have a sensing area of coverage of 30 ft. x 30 ft., and a sensing angle of 180° (see Sensing Area Coverage figure on page 2).
- Adjustable light and time-delay controls are located on the front of the device. See adjustment setting section on page 2 for details.
- LED indicator is used to alert the user of the status of the device.
- Adjustable Time Delay setting for 30 seconds, 5 minutes, 15 minutes and 30 minutes.

DESCRIPTION

The IPV15, which features a Manual-ON operation, is California Title 24 2005 compliant. The unit turns off manually or in absence of motion according to the timeout selected. The IPS15 provides Automatic-ON/OFF operation as well as Manual-OFF with the push pad. These units install in place of a single-pole or 3-way wall switch and fit in a standard wall box. These units can be used for switching incandescent lamps, magnetic fluorescent ballasts, fans, CFL and LED lamps.

LOCATION / MOUNTING

The device responds to temperature changes and care should be taken when mounting the device. **DO NOT** mount directly above a heat source, in a location where hot or cold drafts will blow directly on the sensor, or where unintended motion (e.g., hallway traffic) will be within sensor's field-of-view.

INSTALLING YOUR DEVICE

NOTE: Use check boxes when Steps are completed.

Step 1 **WARNING: TO AVOID FIRE, SHOCK, OR DEATH; TURN OFF POWER** at circuit breaker or fuse and test that power is off before wiring!

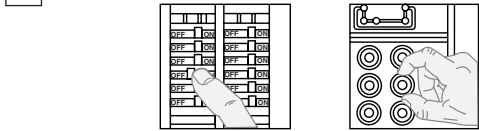

Step 2 **Identifying your wiring application (most common):**

NOTE: If the wiring in the wall box does not resemble any of these configurations, consult an electrician.

Single-Pole

1. Line (Hot)
2. Neutral
3. Ground
4. Load

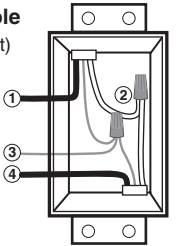

3-Way

1. Line or Load (See important note below)
2. Neutral
3. Ground
4. First Traveler - note color
5. Second Traveler - note color

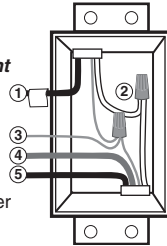

IMPORTANT: For 3-Way applications, note that one of the screw terminals from the old switch being removed will usually be a different color (Black) or labeled Common. Tag that wire with electrical tape and identify as the common (Line or Load) in both the sensor wall box and remote wall box.

Step 3 **Preparing and connecting wires:**

This device can be wired using side wire terminal screws or backwire openings. Choose appropriate wire stripping specifications accordingly.

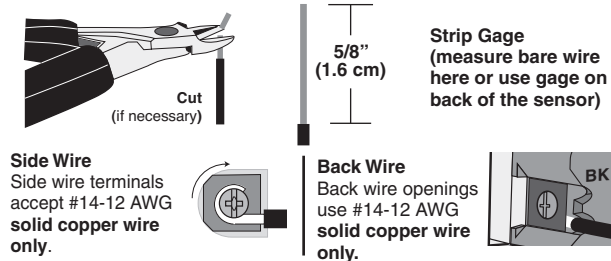

Side Wire
Side wire terminals accept #14-12 AWG solid copper wire only.

Back Wire
Back wire openings use #14-12 AWG solid copper wire only.

- Make sure that the ends of the wires from the wall box are **straight (cut if necessary)**.
- Remove insulation from each wire in the wall box as shown.
- **For Single Pole Application, go to Step 4a.**
- **For 3-Way Wiring with Vizia™ Coordinating Remote (no LED)**

Application, go to Step 4b.
• **For 3-Way Wiring with IPV0R Sensor Remote or Vizia™ Matching Remote (w/LED) Application, go to Step 4c.**

Step 4 **Single Pole Wiring Application:**

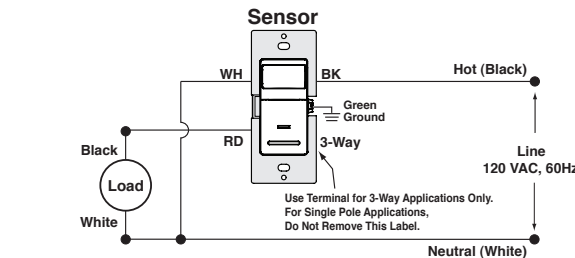
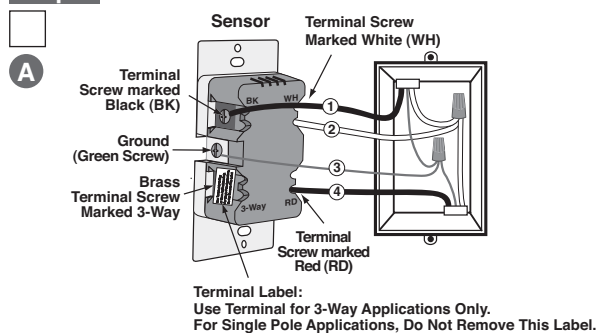

WIRING SENSOR:
Connect wires per WIRING DIAGRAM as follows:

- Green or bare copper wire in wall box to Green terminal screw.
- Line Hot wall box wire to terminal screw marked "BK".
- Load wall box wire to terminal screw marked "RD".
- Line Neutral wall box wire to terminal screw marked "WH".
- Terminal screw marked "3-Way" should have Red insulation label affixed.

NOTE: If insulating label is not affixed to terminal screw marked "3-Way", use electrical tape to cover.

• **Proceed to Step 5.**

Step 4b **3-Way Wiring with Vizia™ Coordinating Remote (no LED) Application:**

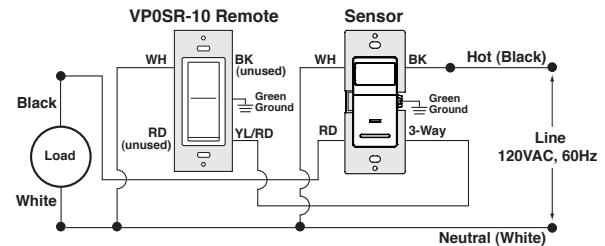
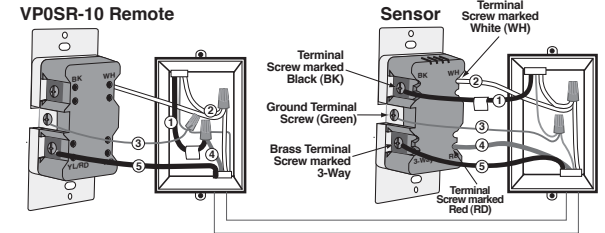

WIRING SENSOR:
Connect wires per WIRING DIAGRAM as follows:

- **NOTE:** The sensor must be installed in a wall box that has a Line Hot connection.
- **NOTE:** Maximum wire length from sensor to remote cannot exceed 300 ft (90 m).
- Green or bare copper wire in wall box to Green terminal screw.
- Line Hot (common) wall box wire identified (tagged) when removing old switch to terminal screw marked "BK".
- First Traveler wall box wire to terminal screw marked "RD" (note wire color).
- Remove Red insulating label from terminal screw marked "3-Way".
- Second Traveler wall box wire to terminal screw marked "3-Way" (note wire color). This traveler from the sensor must go to the terminal screw on the remote marked "YL/RD".
- Neutral wall box wire to terminal screw marked "WH".

WIRING COORDINATING REMOTE:

- **Connect wires per WIRING DIAGRAM as follows:**
- **NOTE:** "BK" and "RD" terminals on coordinating remote are unused. Tighten both screws.
- **NOTE:** Maximum wire length from sensor to remote is 300 ft (90 m).
- Green or bare copper wire in wall box to Green terminal screw.
- Load wall box wire identified (tagged) when removing old switch to First Traveler (note color as above).
- Second Traveler wall box wire (note color as above) to terminal screw marked "YL/RD". This traveler from the remote must go to the terminal screw on the sensor marked "3-Way".
- Remove White insulating label from terminal screw marked "WH".
- Neutral wall box wire to terminal screw marked "WH".
- **Proceed to Step 5.**

LIMITED 5 YEAR WARRANTY AND EXCLUSIONS

Leviton warrants to the original consumer purchaser and not for the benefit of anyone else that this product at the time of its sale by Leviton is free of defects in materials and workmanship under normal and proper use for five years from the purchase date. Leviton's only obligation is to correct such defects by repair or replacement, at its option, if within such five year period the product is returned prepaid, with proof of purchase date, and a description of the problem to Leviton Manufacturing Co., Inc., Attn: Quality Assurance Department, 201 North Service Road, Melville, New York 11747. This warranty excludes and there is disclaimed liability for labor for removal of this product or reinstallation. This warranty is void if this product is installed improperly or in an improper environment, overloaded, misused, opened, abused, or altered in any manner, or is not used under normal operating conditions or not in accordance with any labels or instructions. **There are no other or implied warranties of any kind, including merchantability and fitness for a particular purpose,** is limited to five years. Leviton is not liable for incidental, indirect, special, or consequential damages, including without limitation, damage to, or loss of use of, any equipment, lost sales or profits or delay or failure to perform this warranty obligation. The remedies provided herein are the exclusive remedies under this warranty, whether based on contract, tort or otherwise.

C **3-Way Wiring with Sensor Remote or Vizia™ Matching Remote (w/LED) Application:**
NOTE: IPV0R sensor remote is depicted.

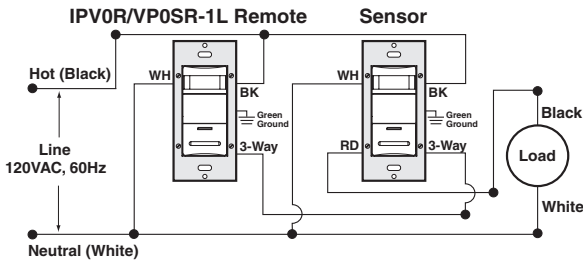
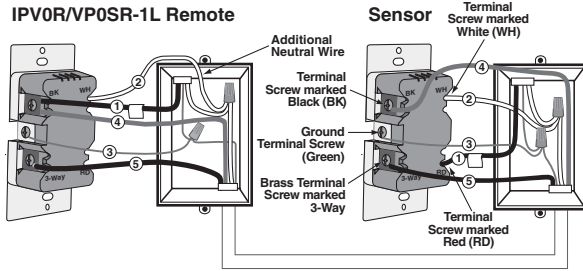

NOTE: The Occupancy sensor **must** be installed in a wall box that has a Load connection. The Sensor remote **must** be installed in a wall box with a Line Hot connection and a Neutral connection. A Neutral wire to the remote needs to be added as shown. If you are unsure about any part of these instructions, consult an electrician.
NOTE: Maximum wire length from sensor to all installed remotes cannot exceed 300 ft (90 m).

WIRING REMOTE (wall box with Line Hot connection):

- Connect wires per WIRING DIAGRAM as follows:**
- Green or bare copper wire in wall box to Green terminal screw.
 - Line Hot (common) wall box wire identified (tagged) when removing old switch and First Traveler to sensor terminal screw marked "BK".
 - Second Traveler wall box wire from sensor to remote terminal screw marked "3-Way" (**note wire color**). This traveler from the remote must go to the terminal screw on the sensor marked "3-Way".
 - Neutral wall box wire to remote terminal screw marked "WH".

WIRING SENSOR (wall box with Load connection):

- Connect wires per WIRING DIAGRAM as follows:**
- Green or bare copper wire in wall box to Green terminal screw.
 - Load wall box wire identified (tagged) when removing old switch to terminal screw marked "RD".
 - First Traveler Line Hot to terminal screw marked "BK".
 - Remove Red insulating label from terminal screw marked "3-Way".
 - Second Traveler wall box wire (**note color as above**) to terminal screw marked "3-Way". This traveler from the sensor must go to the terminal screw on the remote marked "3-Way".
 - Neutral wall box wire to remote terminal screw marked "WH".
 - Proceed to Step 5.**

OPERATION

IPS15

Auto ON: Lights will automatically turn ON when room is occupied or motion is detected. The IPS15 will switch lights OFF when no motion is detected in un-occupied room after set period of time.

Time delay adjustment: Refer to section on Adjustment Settings.

Manual ON: The IPS15 will manually turn-on lights or the load by depressing the push pad on the device. The IPS15 can be set to only turn ON by the pushpad (no automatic on operation) by adjusting the ambient light control to the "0" position.

IPV15

Manual ON: The IPV15 requires the user to manually turn ON lights or the load by depressing the push pad on the device. The lights or load will automatically turn-off when the room is left unoccupied for a set period of time.

Time delay adjustment: Refer to section on Adjustment Settings.

NOTE: In a 3-way application, using vizia™ matching or coordinating remotes, the remote will only have the ability to manually switch the load ON, the sensor will then time out and switch the load OFF once motion is no longer detected. For automatic control at both locations, use IPV0R as the remote.

Locator Light LED:

IPS15: LED blinks when motion is detected and if the load is ON or OFF.
IPV15: LED blinks when motion is detected and when load is ON. LED will remain illuminated when load is OFF.

LOCATOR LIGHT STATUS		
LOAD	IPS15	IPV15
OFF	Blinking	Lit
ON	Blinking	Blinking

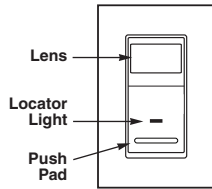

Step 5 Testing your Device prior to mounting in wall box:

NOTE: Dress wires with a bend as shown in diagram in order to relieve stress when mounting device.

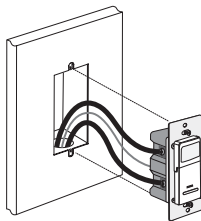

- Position all wires to provide room in outlet wall box for device.
- Ensure that the word "TOP" is facing up on device strap.
- Partially screw in mounting screws in wall box mounting holes.
- Remove the face cover of the sensor to expose the adjustment dials (**refer to Changing the Color of your Device on page 1**).
- Set time selection of the sensor to 30 seconds for a quick time out during testing (**Refer to ADJUSTMENT SETTINGS section**).
- Set the light level dial full clockwise (**Refer to ADJUSTMENT SETTINGS section**).
- Place the face cover back on the sensor.
- Restore power at circuit breaker or fuse.
- For IPS15 lights will automatically turn on after power is applied.
- For IPV15, press and release push pad to turn the lights ON.
- NOTE:** See Locator Light Status chart to confirm the operational state of the device. If lights still do not turn ON, refer to the TROUBLESHOOTING section.
- Leave the room or field of view to allow the sensor to time out and shut off the lights due to absence of motion.
- Within 30 seconds of the lights timing out step back in to the room or the field of view of the sensor and the lights should turn back on automatically.
- If the lights do not turn off 30 seconds after leaving the room decrease the sensitivity of the sensor (**refer to the ADJUSTMENT SETTING section**).
- If the lights to not turn back on automatically when you step back into the room increase the sensitivity of the sensor (**refer to the ADJUSTMENT SETTING section**).
- Set time selection and light level (**Refer to ADJUSTMENT SETTINGS section**).
- When the desired light level (**IPS15 only**), time selection and sensitivity settings are selected place the face cover back on the sensor and continue to Step 6.

Step 6 Device Mounting:
TURN OFF POWER AT CIRCUIT BREAKER OR FUSE.

Installation may now be completed by tightening mounting screws into wall box. Attach wallplate.

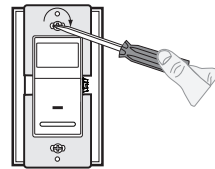

Step 7 Restore Power: Restore power at circuit breaker or fuse.
Installation is complete.

ADJUSTMENT SETTINGS

NOTE: To avoid **PERMANENT DAMAGE** to the unit, be careful **NOT TO OVERTURN** the adjustment dials when setting the Sensor.

1. With power restored and wallplate removed, remove face of device to expose adjustment dials (**refer to Changing the Color of your Device on page 1**). Use a small screwdriver to adjust the light level, time selection and sensitivity on the device as follows (**Refer to Diagram**):

Light Level Adjustment (IPS15 only):

- Adjust the light level dial clockwise. Lights will turn ON in lighter conditions.
- Adjust the light level dial counter clockwise. Lights will turn ON in less lighting conditions.

Time Selection:

- Adjust the time selector dial to the desired length of time the lights are to remain ON. Lights will remain ON from 30 seconds to 30 minutes after the room is vacated.
- Adjust the time selector dial clockwise to increase the duration of the ON time up to 30 minutes.
- Adjust the time selector dial counterclockwise to decrease the duration of the ON time down to 30 sec.

Sensitivity:

- Increase or decrease the sensitivity of the sensor as follows.
- To decrease sensitivity and detection range, rotate the dial counter-clockwise. To increase the sensitivity and detection range, rotate the dial clockwise. With the arrow pointing at 3 the sensitivity is full. With the arrow pointing at 0, the sensitivity is reduced by half. As the dial rotates from 2 to 0, the change in sensitivity is made in fine steps.
- Attach the face cover and test that the light level, time selection and sensitivity are set as desired. If not, repeat adjustments until satisfied.

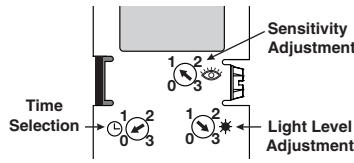

Settings	Time
0	30 sec
1	5 min
2	15 min
3	30 min

TROUBLESHOOTING

Lights do not switch ON - IPS15:

- Motion is beyond sensing range, move closer to switch.
- Adjust the light level adjustment toward lighter or darker, depending on room conditions.

Lights always stay ON:

- Check time delay settings and compare to how long the lights stay ON.
- Be sure that no motion occurs in coverage area for time selected.
- Check that switch is not installed near a heat source (e.g., stove, lights, heat vents) or detecting motion from an adjacent area (e.g., hallway traffic). If so, switch may have to be relocated.
- Try lowering the Sensitivity Adjustment Control. Rotate the knob counterclockwise about 30°. If the problem persists, try reducing again.

NOTE: DO NOT reduce so much that the sensor cannot see normal occupancy.

Lights do not turn ON with the pushpad - IPV15:

- Check that switch is installed correctly.
- Check that power is ON.
- Check that light bulb is functioning.

NOTE: If problems continue, consult an electrician.

SENSING AREA COVERAGE

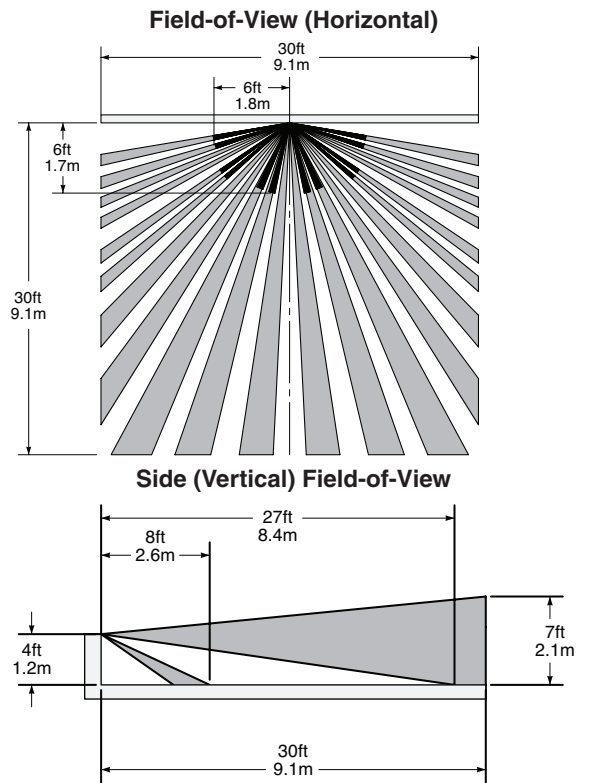

For additional information, contact Leviton's Techline at 1-800-824-3005 or visit Leviton's website at www.leviton.com

This product is covered by U.S. Pat. No. 7,924,155 and corresponding foreign patents.
© 2012 Leviton Manufacturing Co., Inc.
All Rights Including Trade Dress Rights Reserved

FCC COMPLIANCE STATEMENT

This device complies with Part 15 of the FCC Rules. Operation is subject to following two conditions: (1) this device may not cause harmful interference, and (2) this device must accept any interference received, including interference that may cause undesired operation of the device.

This equipment has been tested and found to comply with the limits for a Class B Digital Device, pursuant to Part 15 of the FCC Rules. These limits are designed to provide reasonable protection against harmful interference in a residential installation. This equipment generates, uses, and can radiate radio frequency energy and, if not installed and used in accordance with the instructions, may cause harmful interference to radio communications. However, there is no guarantee that interference will not occur in a particular installation. If this equipment does cause harmful interference to radio or television reception, which can be determined by turning the equipment OFF and ON, the user is encouraged to try to correct the interference by one or more of the following measures:

- Reorient or relocate the receiving Antenna.
- Increase the separation between the equipment and the receiver.
- Connect the equipment into an outlet on a circuit different from that to which the receiver is connected.
- Consult the dealer or an experienced radio/tv technician for help.

FCC CAUTION

Any changes or modifications not expressly approved by Leviton Manufacturing Co., Inc., could void the user's authority to operate the equipment.