

DESCRIPTION

- Includes handshower, hose, and bracket
- Chrome Finish
- 60" double interlock spiral chrome hose (metal)
- 1/2" IPS connection

OPERATION

- Three functions
- Push button feature to change function

FLOW

- Designed to deliver 1.75 gpm (6.6 L/min) MAX at 80 psi

STANDARDS

- Third party certified at WaterSense®, ASME A112.18.1/CSA B-125.1, and all applicable specifications referenced therein
- Products marked with 1.75 gpm are compliant with California water efficiency regulations

WARRANTY

- Lifetime limited warranty against leaks, drips and finish defects to the original homeowner
 - 10 year limited warranty when used in a multifamily installation
 - 5 year limited warranty when used in a commercial installation
- Visit www.moen.com/support for complete details and limitations

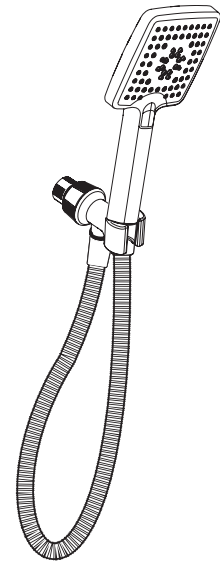

GENTA™
Three-Function Handshower
with Bracket & Hose

Model: 25017

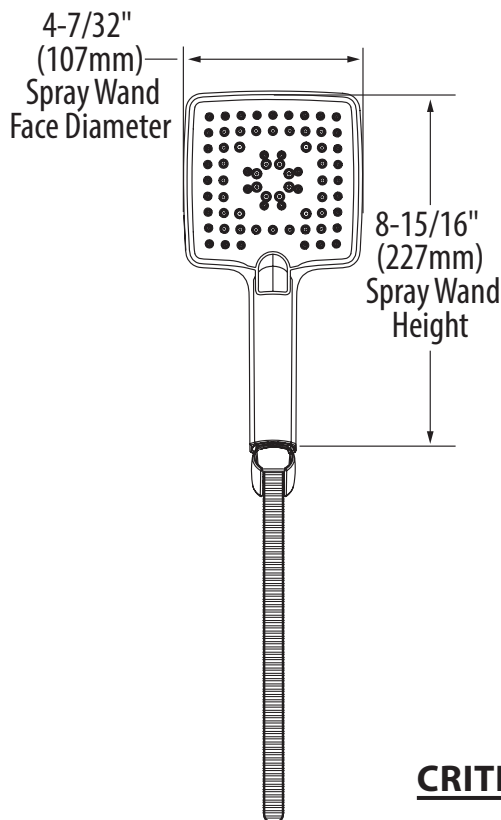

CRITICAL DIMENSIONS

(DO NOT SCALE)

