



**64" Bypass Hardware**

**Oil Rubbed Bronze**

### READ ALL INSTRUCTIONS PRIOR TO STARTING!

#### TOOLS REQUIRED

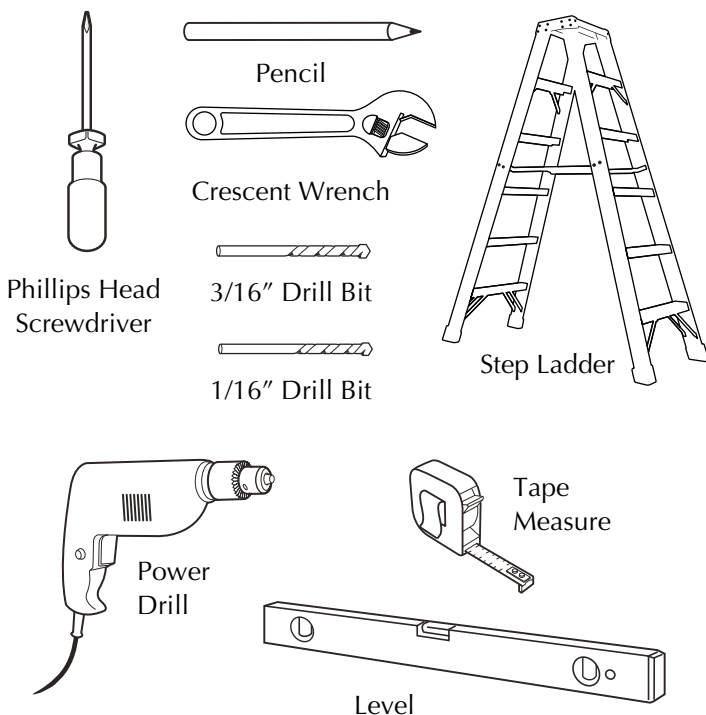

#### BEFORE GETTING STARTED: PRECAUTIONS

1. Please wear safety gear appropriate to tools being used. Eye protection should be used at all times. Failure to use protective eye gear can result in serious injury. **ALWAYS wear proper safety gear when operating power tools.**
2. Always ensure you have ample space to operate power tools with complete control of the power tool.
3. Barn Door installation requires the install of **anti-jump discs** as well as **end stops** to ensure the door cannot come off the track. Failure to properly install these safety items could cause serious injury or even death. These items are required for safe operation of Barn Doors.
4. Some Barn Door components are heavy and should be lifted with care. Mishandling may cause a loss of balance resulting in injury. Always take precaution in assuring proper balance before handling any heavy objects. Safety shoes should also be worn to prevent any foot injuries.
5. The doors roll on the track which can create pinch points (hair, fingers, clothing, etc.). Take precaution when moving the door on the track.
6. Take care in not catching fingers in door opening when sliding the door closed.

## PARTS LIST

1. Wall Bracket
2. Standoff
3. Hex Head Lag Bolt, 3-1/2", Washer
4. Hex Head Lag Bolt, 2-1/2", Washer
5. Hex Bolt, Washer & Open Nut
6. Hex Bolt, Washer & Capped Nut
7. J-Hook / Hanger
8. 64" Track
9. End Stop
10. Anti-jump Disc, Screw
11. T-Guide, Screws

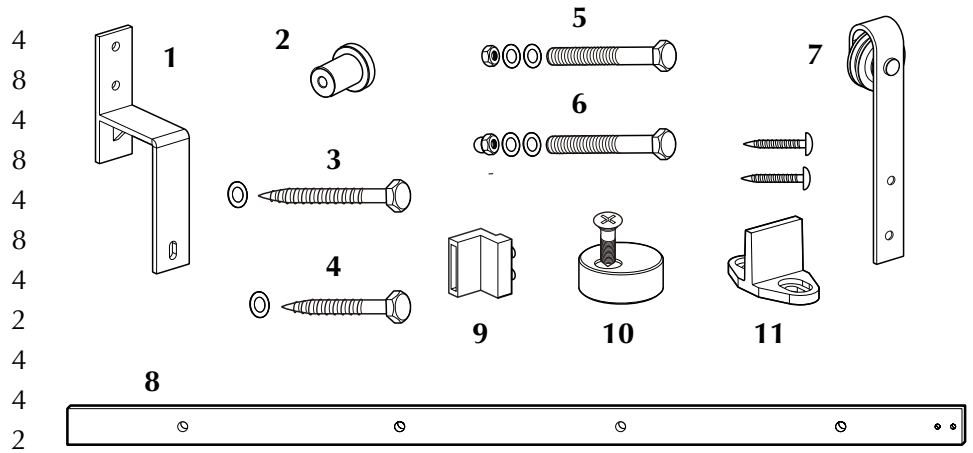

## PRIOR TO INSTALLING HARDWARE

1. Ensure door clearances (figure 1).
2. Install flat, no profile, head casing (not included with Barn Door Bypass Hardware Kit) securely mounted into the wall studs prior to installing the barn door hardware. The head casing should be a minimum of 9" tall x 3/4" thick x 64" long (figure 2). This piece should be made of hardwood. **IT IS CRITICAL this piece be secured in the studs and level for proper travel of the Barn Door.**
3. Finish head casing prior to starting hardware install.

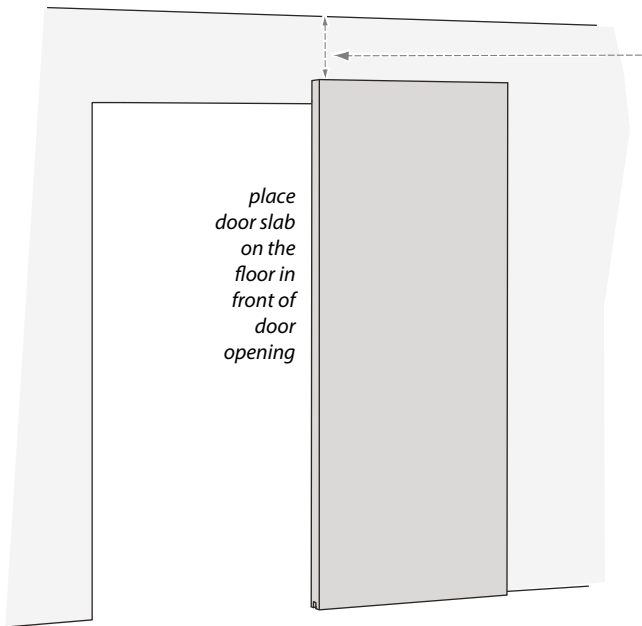

**Figure 1**

*MINIMUM 10" between top of door and ceiling line or bottom of crown moulding (if present)*

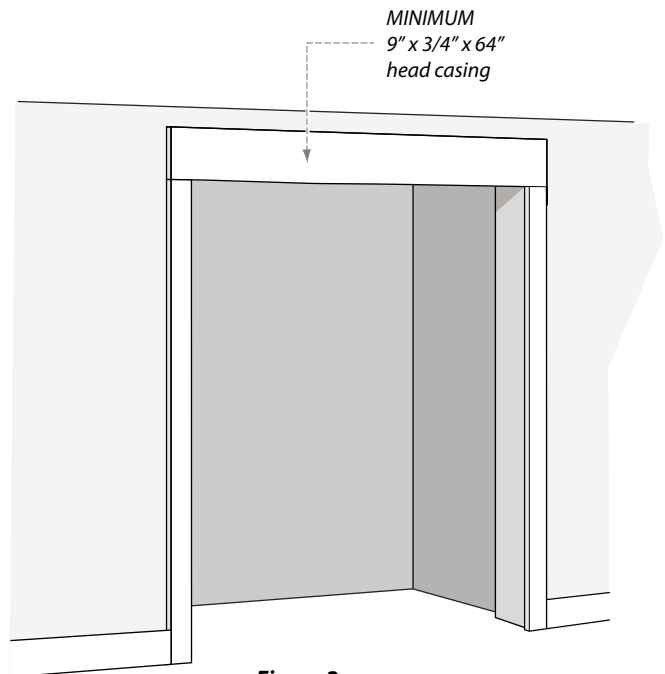

**Figure 2**

## TRACK INSTALLATION

1. First measure/mark bottom row hole location on the head casing (figure 3 & 4).
2. Then, using bottom hole location as a guide, measure/mark hole location of top two rows on the head casing (figure 3A & 4).
3. Drill 3/16" pilot holes (figure 4).  
**MAKE SURE hole marks are level and vertically aligned before drilling.**

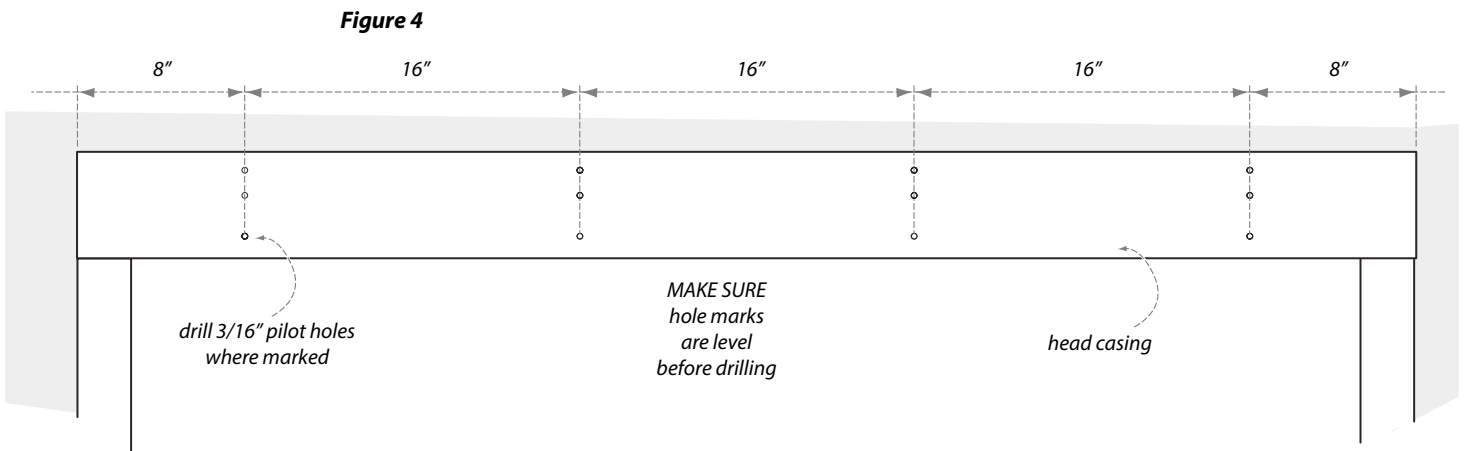
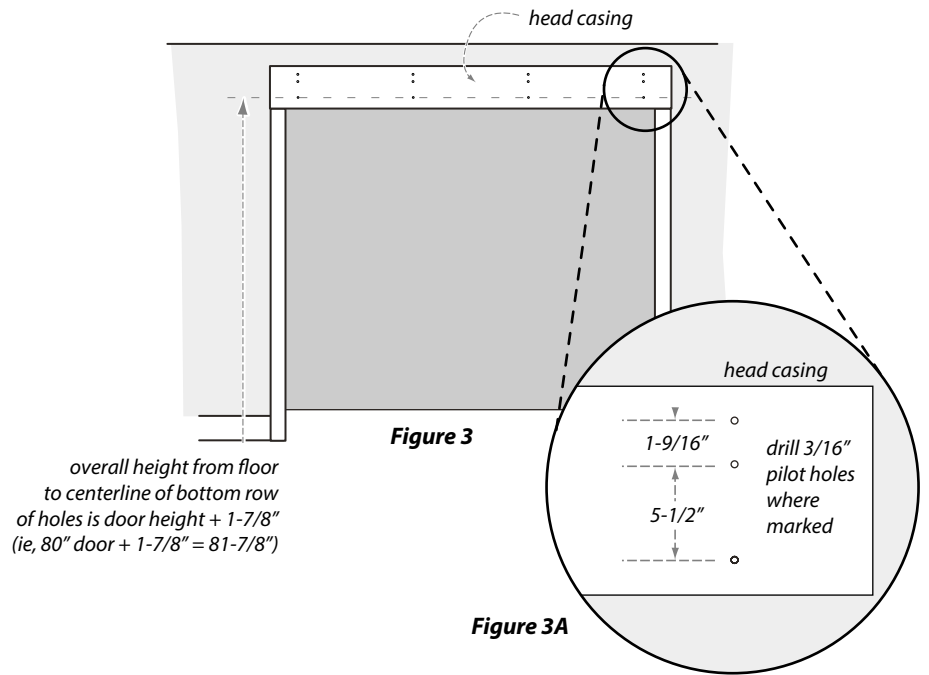

4. Using 3-1/2" Hex Head Lag Bolts (part #3) install the inside Track (part #8) with Standoffs (part #2) between head casing and Track (figure 5).

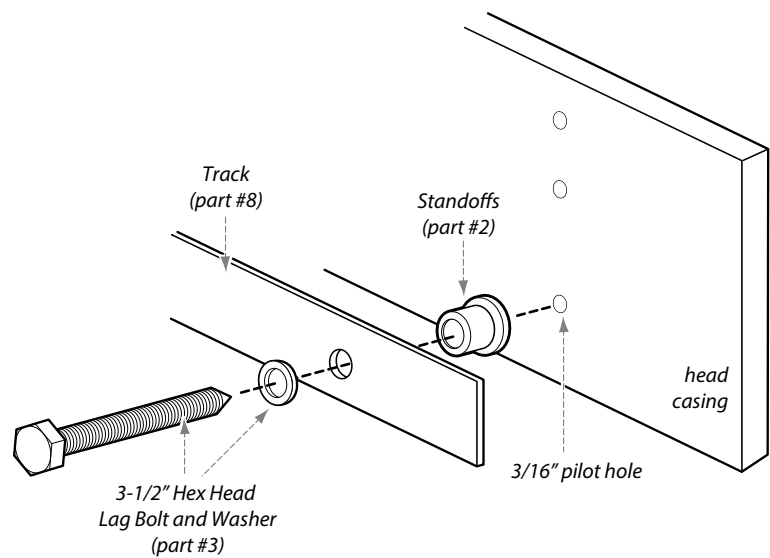
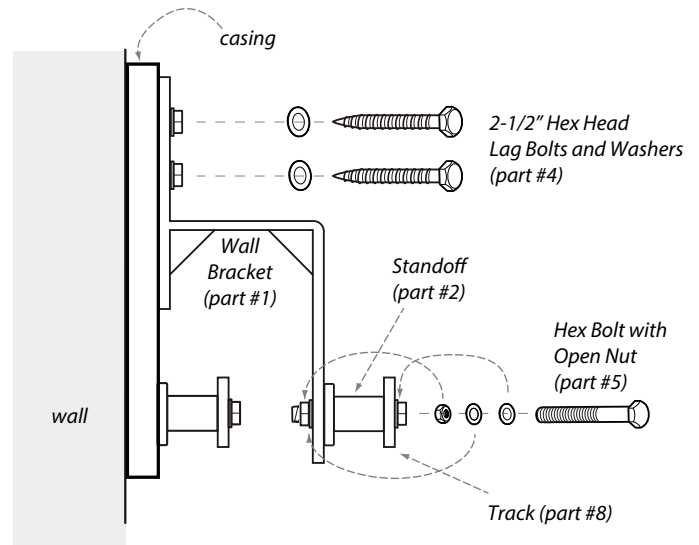

**Figure 5**

## TRACK INSTALLATION (continued)

5. Use 2-1/2" Hex Bolts (part #4) to install Wall Brackets (part #1) to casing (figure 6).
6. Use Hex Bolts with Open Nuts (part #5) and Standoffs (part #2) to mount outside Track (parts #8) to Wall Brackets (figure 6).  
**Make sure** to place washers as shown.

**Figure 6**



## J-HOOK/HANGER & DOOR INSTALLATION

1. Install J-Hook Hangers (part #7) with Hex Bolts with Capped Nuts (part #6) in factory predrilled stile holes as shown (figure 7).
2. Carefully place doors on Tracks (figure 8).

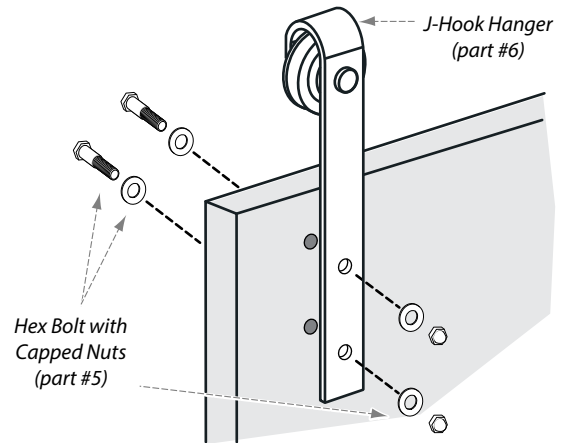

**Figure 7**

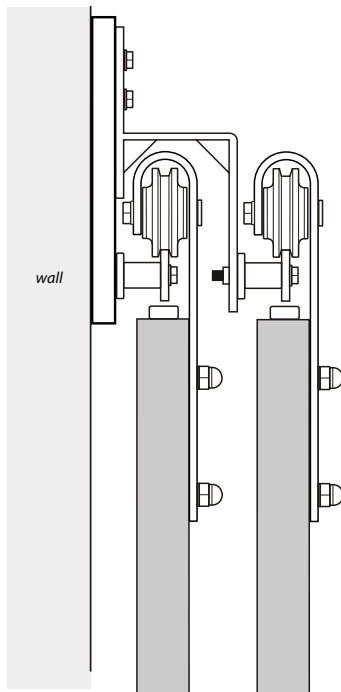

**Figure 8**

## J-HOOK/HANGER & DOOR INSTALLATION (continued)

4. Prior to installing the Anti-Jump Discs (part #10), operate doors back and forth carefully to check all clearances.
5. Once clearances and proper door operation are established, install anti-jump discs as shown 6" to 8" from edge of both doors (figure 9).
6. Measure and mark floor at center point of door opening (figure 10). With inner door hanging vertical (check with level), use the bottom groove of door to position T-Guide (part #11, figure 11) at center point. Roll door to end of Track (figure 10) **taking care not to let it roll off** and install T-Guide in floor. Repeat for outer door. Roll doors back to middle.
7. On both ends of both tracks, install End Stops (part #9) to prevent doors from rolling off (figure 12). Adjust End Stops to desired location.

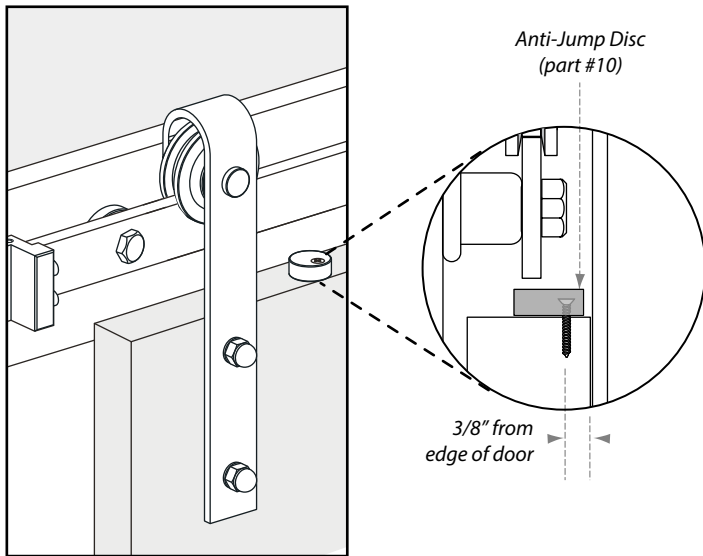

Figure 9

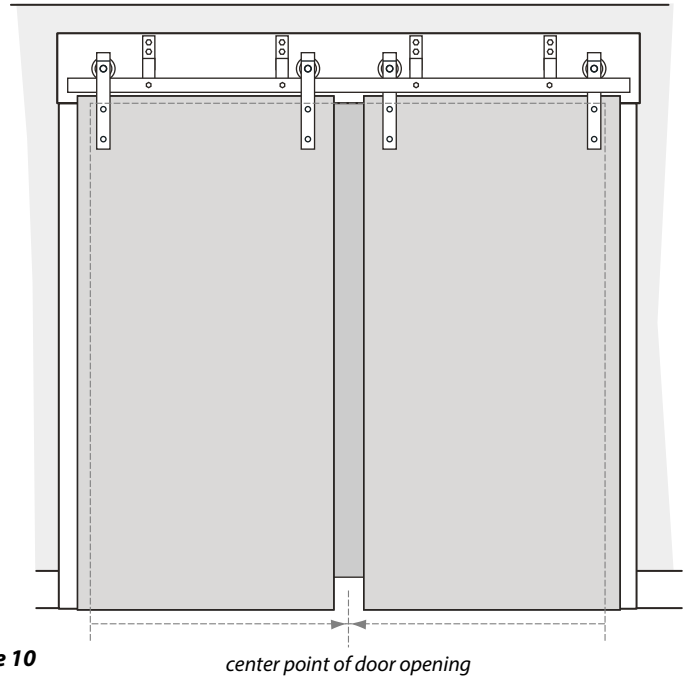

Figure 10

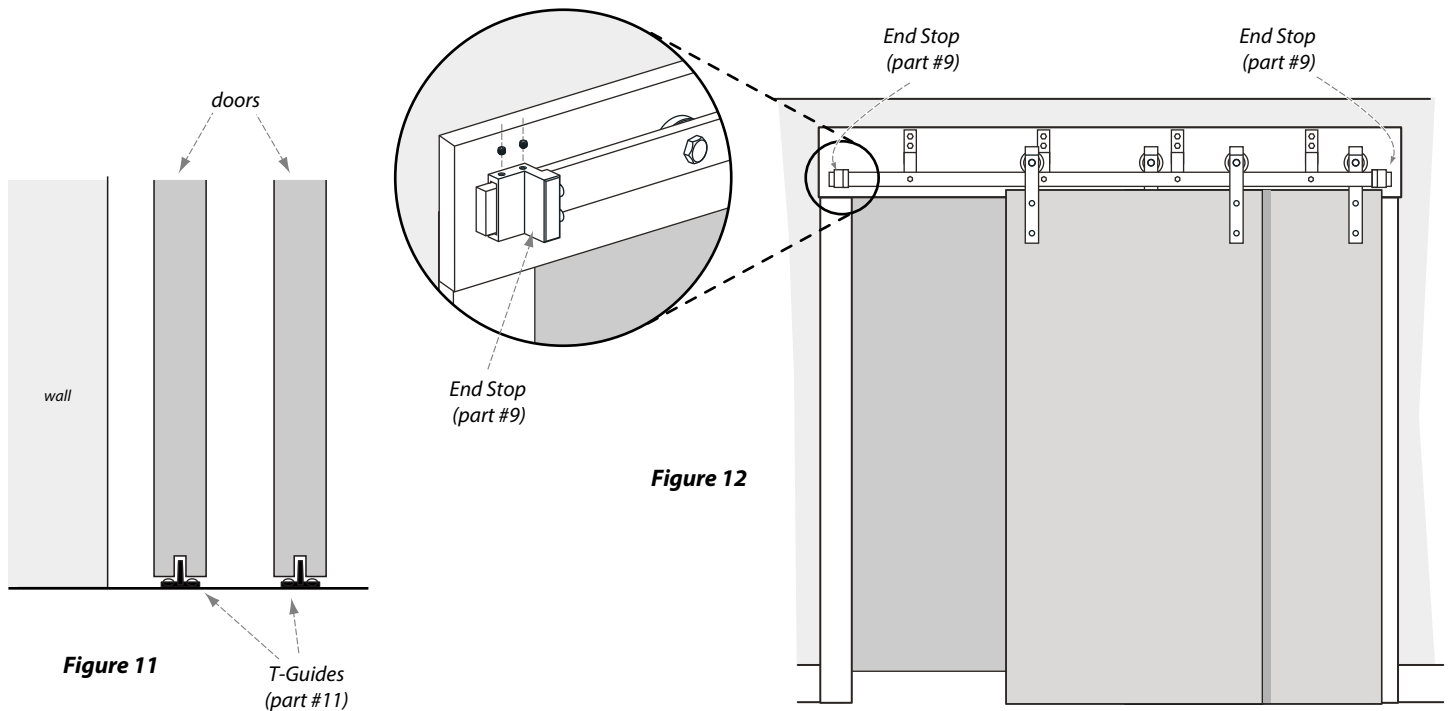

Figure 11

Figure 12