



# Complete Filter Kit with 300 GPH Pump

**REMINDER**  
CALL 1-888-412-6001  
BEFORE RETURNING TO STORE.



**Questions, problems, missing parts?** Before returning to your retailer, call our customer service department at 1-888-412-6001, 8 a.m.-6 p.m., EST, Monday-Friday, or email us at [customercare@totalpond.com](mailto:customercare@totalpond.com). Or visit our website [www.totalpond.com](http://www.totalpond.com).

## PACKAGE CONTENTS

Part	Description	Quantity
A	Filter box top	1
B	Filter box bottom	1
C	Coarse filter pad	1
D	Fine filter pad	1
E	Bio media balls	10
F	3-Tier fountain head	1
G	Diverter valve	1
H	Extension tube	2
I	Pump	1
J	Coupler	1
K	Adapter for 3/4" outlets	1

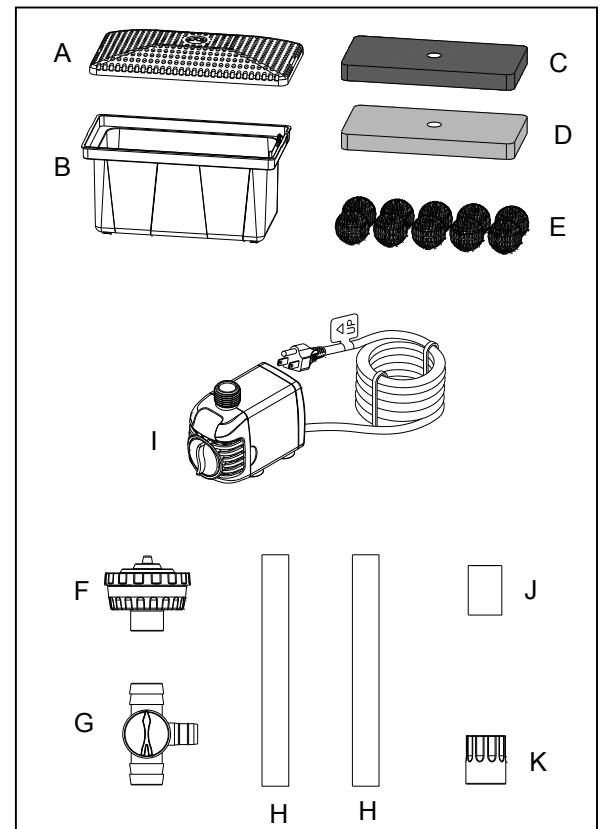

## WARNINGS AND CAUTIONS - PUMP

### WARNING

- Risk of electrical shock. This pump is supplied with a grounding conductor and grounding-type attachment plug. To reduce the risk of electric shock, be certain that it is connected only to a properly grounded, grounding-type receptacle.
- Do not exceed the voltage shown on the pump.
- Always disconnect pump from the power source before beginning any maintenance or work on the pump.
- Inspect cord for damage before installation and/or maintenance. Replace the entire pump assembly if damage is found.
- Do not remove the grounding pin from the power cord plug.
- Risk of electrical shock – This pump has not been investigated for use in swimming pool or marine areas.

## CAUTION

- This pump has been evaluated for use with fresh water only.
- Use a proper power source as indicated on the pump label.
- Keep the cord away from high temperatures or other heat sources.
- Do not pump heated liquids.
- Do not let the pump run dry. Pump must be completely submerged for proper operation and cooling.
- Operate in freshwater only. Avoid heavily chlorinated water and water with high pH levels.
- Do not lift the pump by its power cord.

## PREPARATION

Before beginning assembly of product, make sure all parts are present. Compare parts with package contents list and diagram above. If any part is missing or damaged, do not attempt to assemble, install or operate the product. Contact customer service for replacement parts.

- Estimated Assembly Time: 15 minutes
- No tools required for assembly.

## PRODUCT DESCRIPTION

This is a general purpose, mechanical / biological filter system. It is designed to filter the water and promote healthy bacteria that will provide a balanced environment in your pond. This filter is designed to work with a water pump that can circulate a minimum of 200 gallons per hour. As a pre-filter, this prefilter reduces pond debris and particulate before they enter the pump and other pond accessories. This pre-filtration reduces the clogging of your pump and accessories and minimizes the need for cleaning.

## ASSEMBLY INSTRUCTIONS

1. Place your pump inside the filter box bottom, close to the center. Make sure that the outlet points up. Route the cord through the hole in the top corner of the filter box bottom. Fig. 1

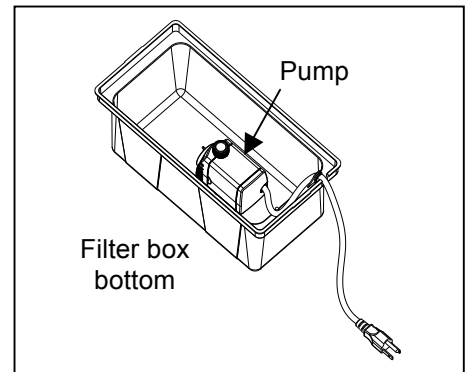

Fig. 1

2. Place the bio media balls around the pump. Fig. 2

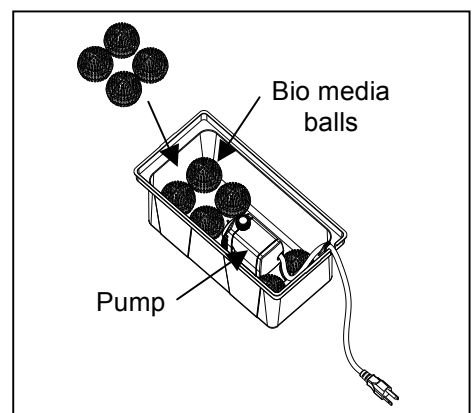
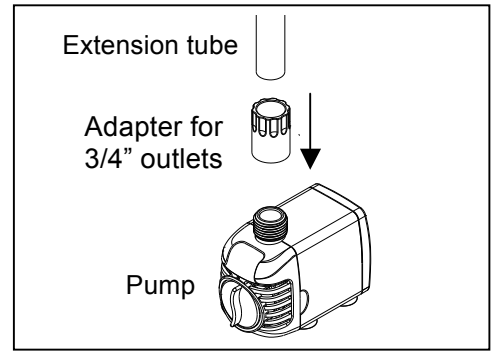

Fig. 2

3. Connect the extension tube to the outlet of the pump using the supplied adapter for 3/4" outlets. Fig. 3



**Fig. 3**

4. Place one of the fine filter pads over the bio media balls and pump. Then place one of the coarse filter pads over the fine filter pad. Fig. 4

NOTE: The fine filter pad is blue and the coarse filter pad is black.

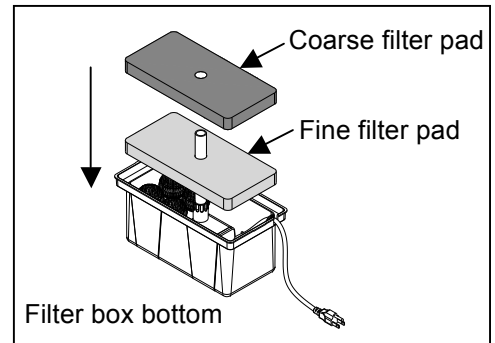

**Fig. 4**

5. Place the filter box top on top of the filter box bottom. It should snap closed. Fig. 5

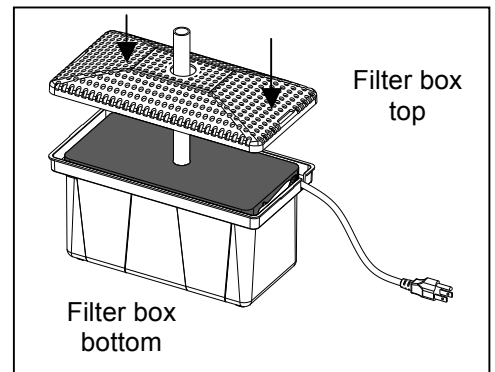
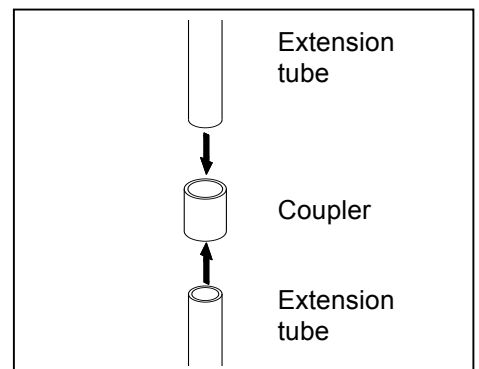

**Fig. 5**

**NOTE: This kit includes a coupler and a diverter valve.**

- a. To flow water to the fountain head only, use the coupler. (Proceed to step 6)
- b. To flow water to the fountain head and a spitter, use the diverter valve. (Skip to step 9)

6. Connect the two extension tubes with the coupler. Fig. 6



**Fig. 6**

7. Connect the fountain head on the top extension tube. Fig. 7

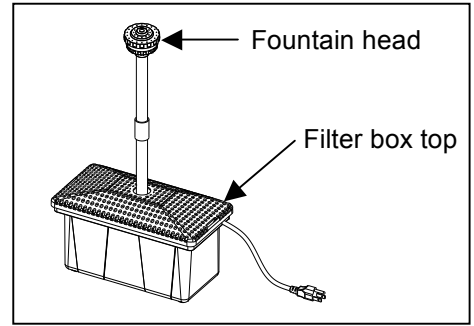

Fig. 7

8. Place the filter assembly in the water. Fig. 8

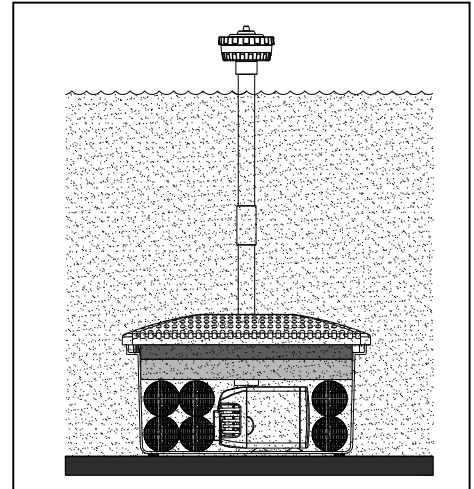

Fig. 8

9. Connect the extension tubes to the diverter valve. Make sure the arrow on the valve is positioned as shown and the diverter valve is connected as shown. Fig. 9

NOTE : Use diverter valve to simultaneously run a spitter and fountain head from one pump.

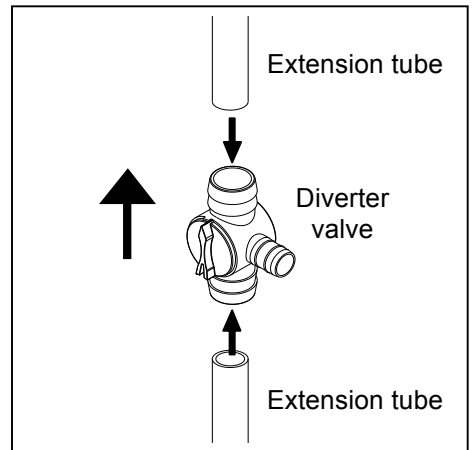

Fig. 9

10. For 1/2 in. tubing, connect the tubing onto the second output of the diverter valve. Connect the other end of the tubing to a spitter or other water feature. Fig. 10

NOTE: Tubing and spitter are NOT INCLUDED.

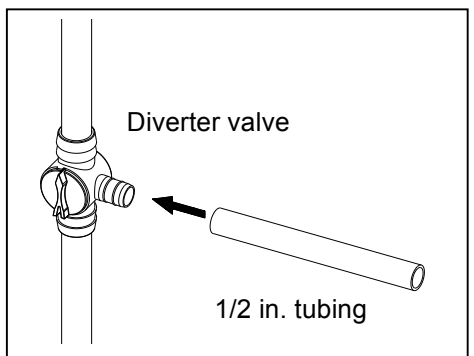

Fig. 10

11. Connect the fountain head to the top extension tube. Adjust the diverter valve to split the flow between the fountain head and the spitter. Fig. 11

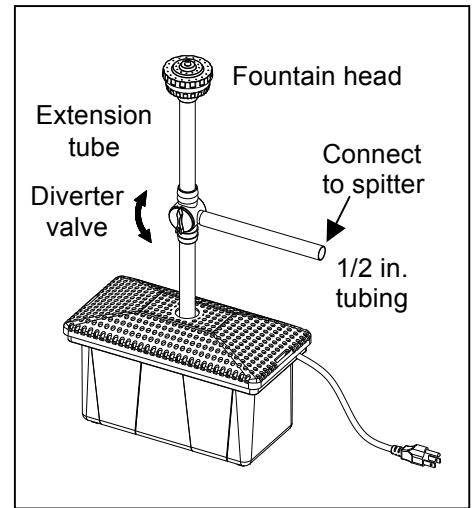

Fig. 11

12. Place the filter assembly in the water. Fig. 12

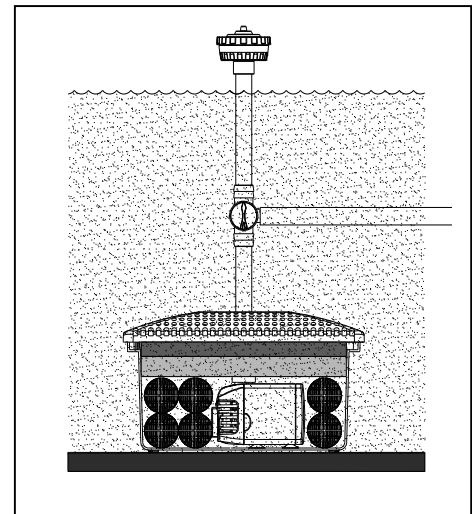

Fig. 12

## CARE AND MAINTENANCE - FILTER

- Occasional cleaning of the filter pads will be necessary to ensure the proper functioning of the system. The coarse filter pad is designed to trap large debris. The fine filter pad catches smaller particles. All pads should be removed and washed with clean water when they are visibly soiled.
- Filter pads should be replaced annually. The exterior surface of the filter box may also need occasional cleaning. Particularly if the openings in the top of the filter box are obstructed. When cleaning the filter box use warm water only. Do not use any chemicals that may destroy the beneficial bacteria.
- The bio media balls in your filter system and the inside surfaces of the filter box bottom contain the beneficial bacteria. At least once a year the entire system should be disassembled and cleaned thoroughly using warm, soapy water (mild detergent). This should not be done during the warm season as it may take up to 8 weeks to re-establish the environmental balance. The best time of the year to “breakdown” your system is in early spring before the water temperatures begin to rise. This is also the ideal time to replace the filter pads.

## CARE AND MAINTENANCE – PUMP

- Regular cleaning of the pump may be necessary depending upon the environment in which it is operated. Clean the pump when it is visibly soiled or when a drop in performance is detected.
- Before cleaning, always disconnect the pump from the power source.
- Remove all parts from the pump and clean in warm, soapy water.
- Disassemble the front cover and remove the impeller cover to expose the impeller assembly. Remove the impeller assembly by gently pulling on the impeller blades. Use a soft cloth or brush to clean the impeller assembly and the inside of the impeller housing.

## TROUBLESHOOTING – PUMP

If the pump fails to operate:

- Check to make sure the power cord is plugged in and the pump is getting power.
- Check the pump outlet and any tubing, fountains, spitters etc. for kinks or obstructions.
- Remove the filter screen and/or front cover, and impeller cover to expose the impeller. Turn the impeller to ensure that it is not broken or jammed.

If the performance of the pump is not satisfactory or the pump does not flow evenly:

- Check to make sure the pump is completely submerged in water.
- Check to make sure the impeller and the impeller housing are clean.
- Adjust flow control knob.

## REPLACEMENT PARTS LIST

For replacement parts, call our customer service department at 1-888-412-6001, 8 a.m.-6 p.m., EST, Monday-Friday.

Part	Description
A	Filter box top
B	Filter box bottom
F	3-Tier fountain head
G	Diverter valve
H	Extension tube
J	Coupler
K	Adapter for 3/4" outlets
L	Flow control knob
M	Front cover
N	Impeller cover
O	Shaft support
P	Shaft
Q	Impeller assembly

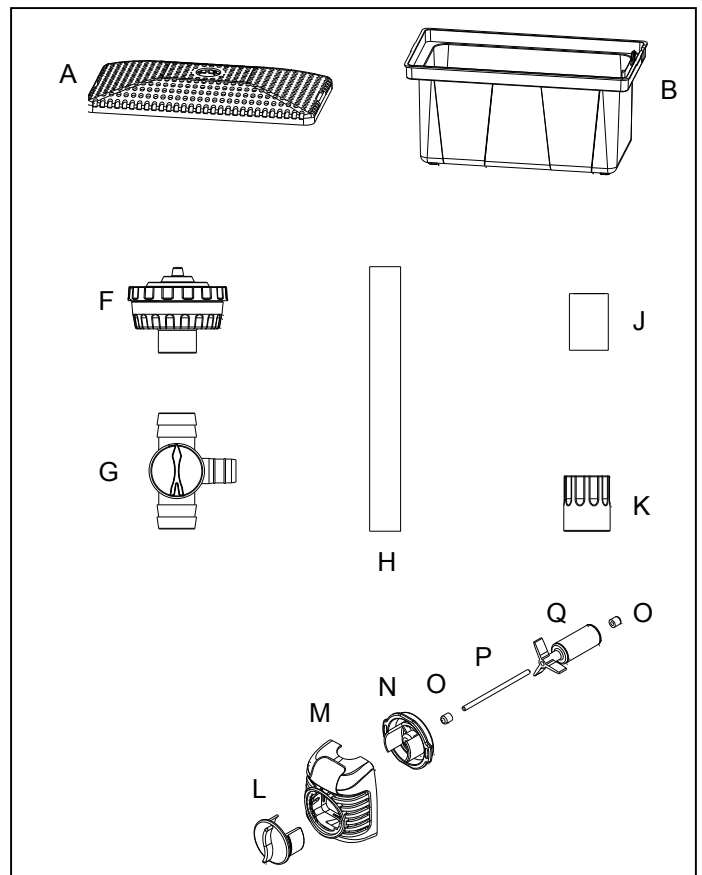

TotalPond replacement filters can be purchased at Home Depot, item #RF13021.

Printed in China

## **LIMITED WARRANTY**

---

All pumps and electrical products are warranted to the user against defective material and workmanship, under normal working conditions. This warranty period begins on the date of purchase by the original purchaser.

TotalPond® pond and waterfall pumps are warranted to the user against defective material and workmanship, under normal working conditions for 2 years from the date of purchase. All other TotalPond® electrical products are warranted to the user against defective material and workmanship, under normal working conditions for 1 year from the date of purchase. All TotalPond® liners are warranted to the user against defective workmanship, under normal working conditions for 20 years from the date of purchase. All other TotalPond® product is warranted to the user against defective material and workmanship, under normal working conditions for 90 days.

### **Application**

Warranty covers only properly installed and maintained units. Pump warranty is limited to applications pumping fresh water in a pond or fountain only. Other liquid applications or extreme temperature uses must be approved in writing by the manufacturer. Receipt and product date code are required for warranty claims.

### **Warranty Claim**

**Warranty claims must be made by calling customer service (at 1-888-412-6001).** If the item is determined to be defective, you will be given authorization to return the defective part(s), freight pre-paid, along with proof of purchase.

### **Disposition**

The manufacturer will make a good faith effort for prompt disposition regarding all warranty claims. Returned product will be inspected to determine cause of failure before warranty is applied. Warranty does not cover any costs associated with the shipping, handling, installation or removal of products or parts subject to this warranty. For products damaged in transit, a claim should be filed with the carrier.

### **Disclaimer**

Any oral statements made about the product by the seller, the manufacturer, the representatives, or any other parties do not constitute warranties, should not be relied upon by the user, and are not part of the contract for sale. The seller's and manufacturer's only obligation, and buyer's only remedy shall be for the manufacturer to either replace and/or repair at the manufacturer's sole discretion, the product as described above. Neither seller nor the manufacturer shall be liable for injury, loss or damages for lost profits, lost sales, injury to person or property, or any other incidental or consequential loss arising from any cause whatsoever, no matter whether based upon warranty, contract, negligence or other misuse, and the buyer and user agree that no other remedy shall be available to them. Before using, the buyer and user shall determine the suitability of the product for the intended use, and assume all risk and liability whatsoever in connection therewith. The warranty and remedy described in this limited warranty is an exclusive warranty and remedy in lieu of any other warranty or remedy expressed or implied. All other warranties and remedies are hereby expressly excluded, including but not limited to any implied warranty of merchantability of fitness for any particular purpose. This warranty gives the buyer and user specific legal rights, and buyer and user may also have other rights which vary from state to state. Some states do not allow exclusions or limitations of incidental or consequential damages, so the above limitations or exclusions may not apply to you.

# **REMINDER**

**CALL 1-888-412-6001**

**BEFORE RETURNING TO STORE**