



34099 Melinz Pkwy Unit E - Eastlake OH - 44095 - 440-359-7200 - info@uslightinggroup.com - http://uslightinggroup.com

Installation Manual

GFY-110 Series

GFY-110 Series LED tubes are designed to replace T8 fluorescent lamps in fixtures containing standard G13 (bi-pin) sockets. Do not attempt to install in other types of fixtures.

Part Number Matrix

Model	Length, ft	Voltage, Volts	Color Temp, Kelvin	Cover
GFY-110-35-C	4	110	3450	CLEAR
GFY-110-35-D	4	110	3450	DIFFUSED
GFY-110-45-C	4	110	4500	CLEAR
GFY-110-45-D	4	110	4500	DIFFUSED
GFY-110-65-C	4	110	6500	CLEAR
GFY-110-65-D	4	110	6500	DIFFUSED

Please read this manual carefully before performing an installation.

WARNING: THIS PRODUCT MUST BE INSTALLED IN ACCORDANCE WITH THE APPLICABLE INSTALLATION CODE BY A PERSON FAMILIAR WITH THE CONSTRUCTION AND OPERATION OF THE PRODUCT AND THE HAZARDS INVOLVED.

IMPORTANT: The tubes have to be connected directly to 110 VAC and not to the existing ballast in the fixture. Connecting the tubes to the fixture without bypassing the ballast will permanently damage the tubes and the fixture.

IMPORTANT: The electrical rating of these products is 110 VAC, the installer must determine voltage in existing fixture prior to installation.

This Kit Includes:

- LED lamp
- Luminaire pressure sensitive label
- N label (neutral marking at lampholder terminal)

Application

- These LED tubes are suitable for installation in T8 standard luminaries with non-shunted lampholders (rapid start ballasts).
- These LED tubes can't retrofit original luminaries which use remote starter.

- These LED tubes are intended to retrofit maximum two lamps, UL listed surface mount, or type IC or non-IC recessed mount fluorescent luminaires with diffuser that use straight tubular lamps in luminaire of the following size (Length x Width x Height) – 120 x 60 x 8 cm.
- These LED tubes are intended for dry locations only.

Figure 1.1

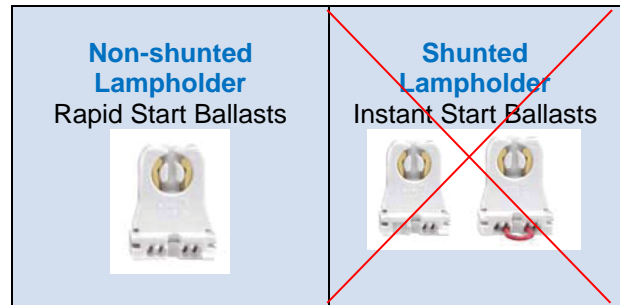

IMPORTANT!
Prior to Installation:

- Inspect existing wiring for applicable ratings.
- Ensure that the lampholders have the appropriate electrical ratings.
- Determine the type of lampholders present in the luminaire. Refer to Figure 1.1 to determine the correct type of lampholders.

This retrofit kit is for use with non-shunted lampholders only. Do not attempt to use on luminaires with shunted lampholders.

Installation Steps

1. Turn off all power to the light fixture.
2. Remove diffuser (if applicable) and fluorescent lamp. (Figure 2.2)
3. Open the wiring compartment and bypass all ballasts and starters (cut off all wires which connect to ballast) (Figure 2.4).
4. Connect one wire from one side of the lampholder to live wire of the AC Mains.
5. Connect the other wire from the other side of the lampholder to neutral wire of the AC Mains. The polarity of the connections does not matter.

IMPORTANT: Live and neutral wires must be connected to different pins of the same lampholder. Do not connect wires to the opposite lampholders.

6. Remove unused wiring on unused lampholder (Figure 2.4)
7. Repeat the steps if installing more than one lamp in the fixture. Refer to Figure 3.1, 3.2 and 3.3 for wiring diagrams of specific types of luminaires.
8. Close up wiring compartment.
9. Insert LED tubes.
10. Mark Neutral terminal of the lampholder with the label reading **N** (included)
11. Affix included Luminaire Label to the luminaire where it can be clearly seen.
12. Turn the power back on and enjoy the LED lamps.

Figure 2.1



Figure 2.2

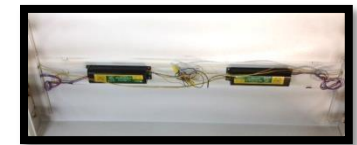

Figure 2.3



Figure 2.4



Figure 2.5



Figure 3.1

One Lamp Luminaire Retrofit

Before

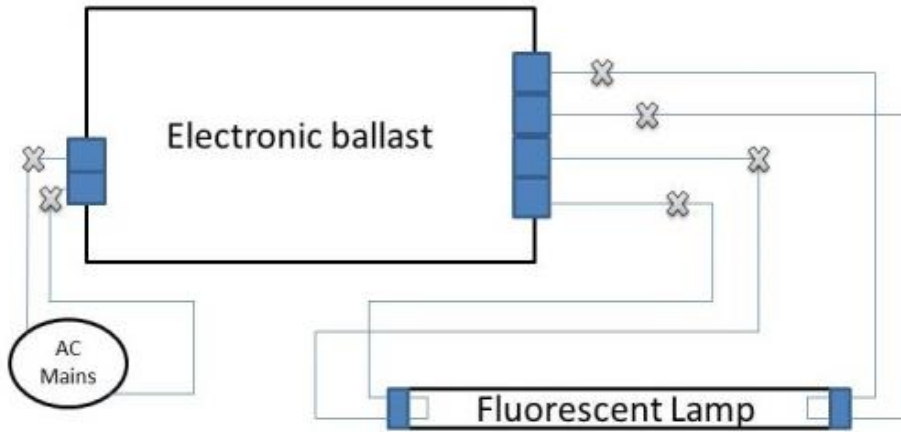

After

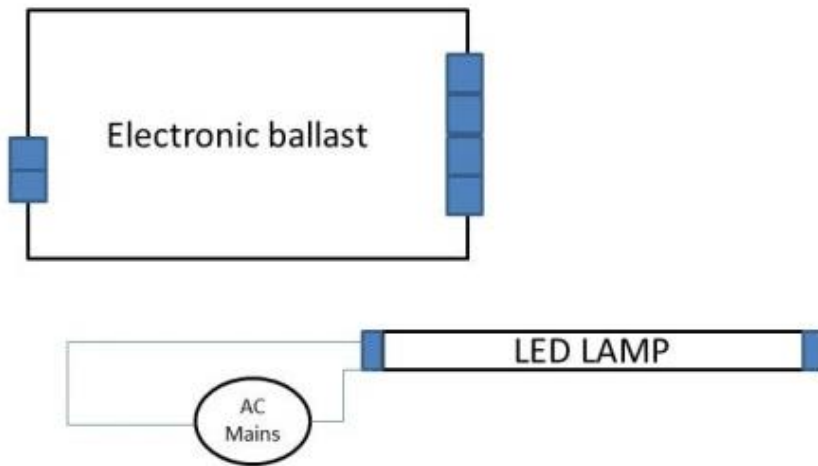
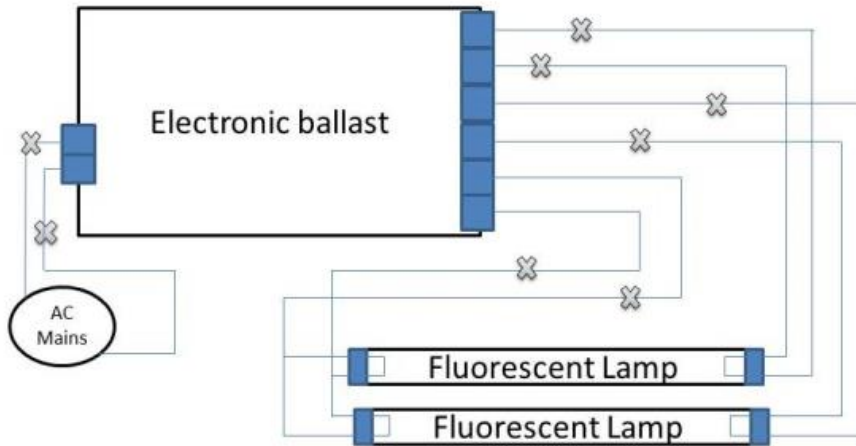

Figure 3.2

Double Lamp Luminaire Retrofit

Before



After

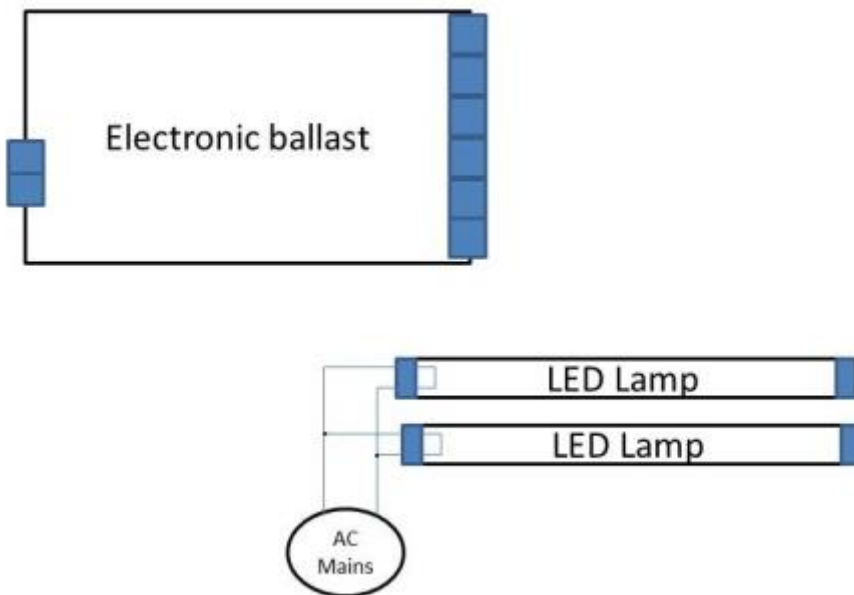
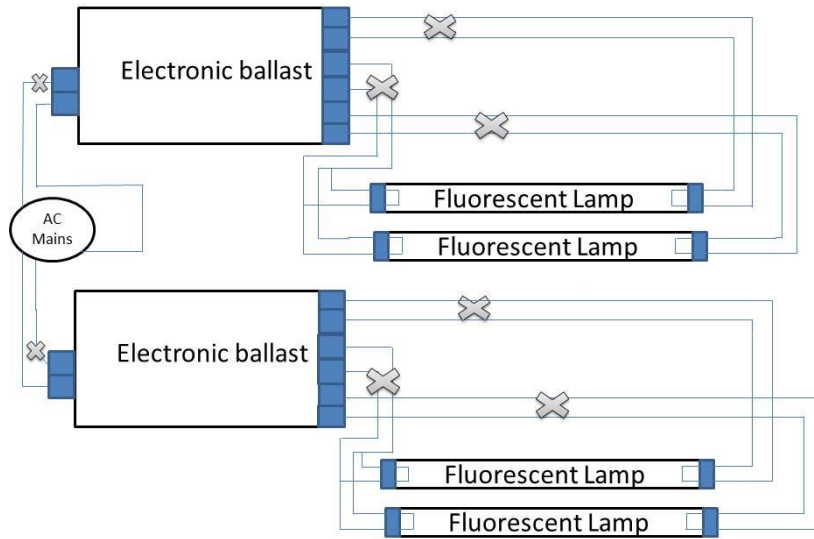

Figure 3.3

Four Lamps/Double Ballast Luminaire Retrofit

Before



After

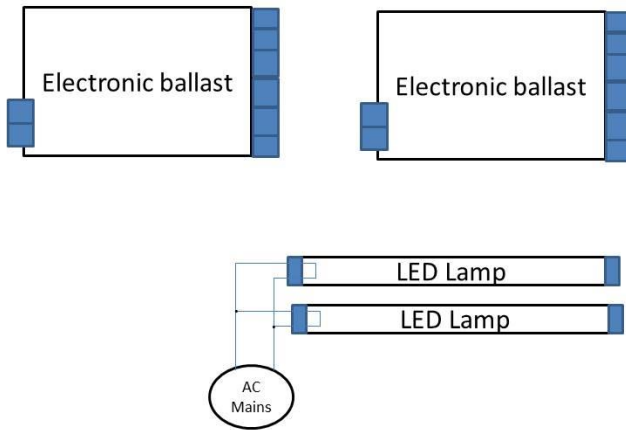

SAFETY NOTICE

DANGER - RISK OF FIRE OR ELECTRIC SHOCK

1. **WARNING** – Risk of fire or electric shock. Luminaire wiring and electrical parts may be damaged when drilling for installation of LED retrofit kit. Check for enclosed wiring and components.
2. **WARNING** – Risk of fire or electric shock. LED Retrofit Kit installation requires knowledge of luminaires electrical systems. If not qualified, do not attempt installation. Contact a qualified technician.
3. **WARNING** – Risk of fire or electric shock. Install this kit only in the luminaires that have the construction features and dimensions listed in this Manual.
4. Do not make or alter any open holes in an enclosure of wiring or electrical components during kit installation.
5. **WARNING** – To prevent wiring damage or abrasion, do not expose wiring to edges of sheet metal or other sharp objects.
6. **WARNING** – To avoid potential fire or shock hazard, do not use this retrofit kit in luminaires employing shunted bi-pin lampholders. Note: Shunted lamp holders are found only in fluorescent luminaires with Instant-Start ballasts. Instant-start ballasts can be identified by the words “Instant Start” or “I.S.” marked on the ballast. This designation may be in the form of a statement pertaining to the ballast itself, or may be combined with the marking for the lamps with which the ballast is intended to be used, for example F40T12/IS. For more information, contact the LED luminaire retrofit kit manufacturer.
7. Installers should not disconnect existing wires from lampholder terminals to make new connections at lampholder terminals. Instead installers should cut existing lampholder leads away from the lampholder and make new electrical connections to lampholder lead wires by employing applicable connectors.

Always use UL approved wire nuts when bypassing ballasts and re-wiring fixtures.

DO NOT USE WITH DIMMERS.

SUITABLE FOR DRY LOCATIONS ONLY.

THIS PRODUCT IS NOT DESIGNED FOR USE WITH EMERGENCY EXITS.