

For Professional Technical Support call **1-844-883-1872**

## Where Used

When a large volume of water is needed and unlimited water supply is available; open water source; multiple driven points; or high volume shallow wells-suction lift 20' or less.

## Typical Application

Sprinkler systems that have single/multiple zones with more than 2-3 heads per zone.  
Movement of large volume of water from water source to place of usage.

## Types of Sprinkler Pumps

Thermoplastic models are constructed of fiberglass-reinforced thermoplastic offering corrosion-resistance. Suction lift is 20' or less.

## Typical Installations

### Open Water Installation

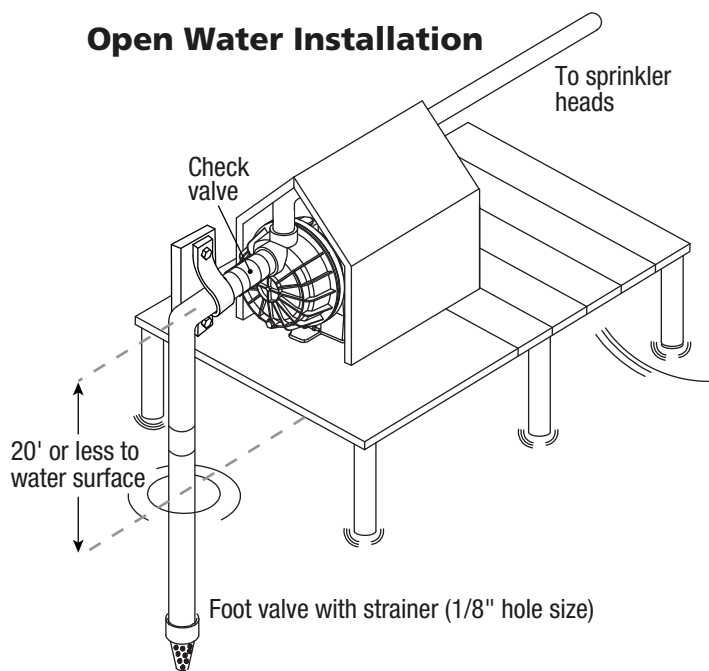

Support all piping connected to the pump due to weight of water in pipes.

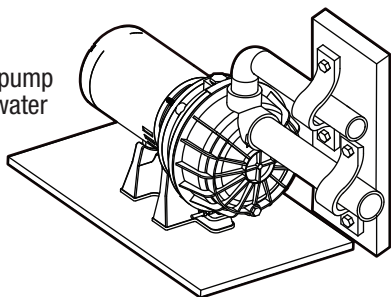

### Multiple Driven Points Installation

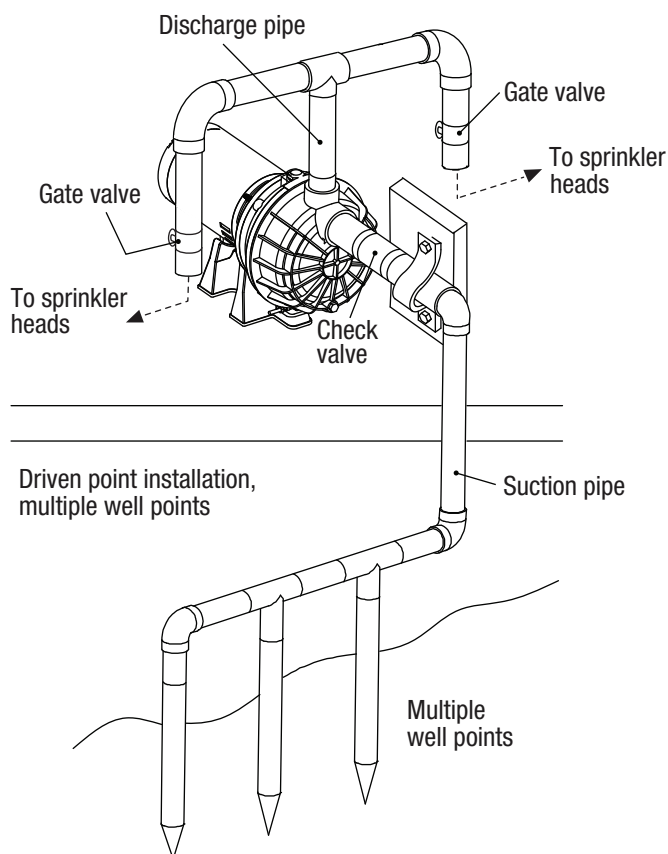

## Frequently Asked Questions

### 1. How do I select the right pump for my application?

In a sprinkling application, determine the suction lift and the maximum number of sprinkler heads that will be on at any one time. Take number of heads x 3 for total demand. Look at pump performance chart and find pump that will deliver total demand or greater at suction lift at 30 psi.

In a transfer application select the pump that gives you the best performance for your needs.

Verify voltage of 115 volt or 230 volt.

### 2. Can I use any size pipe available?

Always use the same size pipe as the pump is designed for. Smaller piping will lessen the performance of the pump affecting the job coverage.

**See reverse for additional FAQs**



## Frequently Asked Questions

### 3. What additional items do I need?

In an open water or shallow well application a foot valve will be needed to prevent pumped water from returning to water source keeping the pump primed.

In usage on a driven point a check valve will be needed to prevent water from returning to water source.

See typical installation for appropriate pump.

### 4. Why is my motor hot?

Electric motors are designed to endure a certain amount of heat. The pump motor has an internal thermal overload protector that will temporarily shut the pump off if it gets above its design operating temperature.

### 5. How do I know what voltage to set the voltage switch to?

Use a volt meter to measure the voltage at the pump. Refer to a licensed electrician if you do not have a strong understanding of electrical systems and safety.

### 6. How do I know what size wire to use between the pump and breaker panel?

Refer to your Owner's Manual for a guide to wire and breaker size based on voltage and distance between breaker panel and pump. Undersized wire will cause performance and safety problems!

### 7. My pump is very loud, what is wrong?

The pump noise level will vary depending on the discharge flow rate, and other aspects of the overall system. Often times, excessive noise is a result of the pump running at full flow without adequate discharge pressure.

This can be improved by partially closing a valve placed near the discharge of the pump. Slowly close the valve until the pump sounds like it is running smoothly and can provide adequate performance for the system.

### 8. My pump is not working, what should I do?

Check your suction line for leaks. Even a pin hole leak can cause the pump to not properly prime or hold a prime

Check the voltage at the pump with a volt meter to ensure there is not a low-voltage condition.

Check your impeller for jams or debris and clean if present.

### 9. Can my pump be installed outdoors and exposed to the weather?

The motor is of the Open Drip Proof design. This does not mean waterproof, but rather it can withstand light moisture from above. The motor ventilation slots are on the underside of the motor. If the pump is installed fully exposed in areas with very heavy rain or flooding, water can enter the motor from below and cause short circuit failure. Depending on your local weather, it is strongly advised that the pump be covered by a well ventilated roof structure, similar to a doghouse with ventilated walls.

Ensure that you are using a check valve or foot valve per the Owner's Manual. The type of valve you use depends on the type of installation, so always use the proper valve. If the valve is clogged with debris or otherwise not operating properly, it will cause the pump to lose prime and/or not develop flow. It is always recommended to replace suction line and valves when replacing an old pump.

