



OWNERS MANUAL

for

BTIS1	BS611	BTISCE240EU	
The Black Bradley Smoker 120V	The 'Original' Bradley Smoker 120V	The Black Bradley Smoker 240V	
BTDS76P	BTDS108P	BTDS76CE-EU	BTDS108CE-EU
Bradley 4 Rack Digital Smoker 120V	Bradley 6 Rack Digital Smoker 120V	Bradley 4 Rack Digital Smoker 240V	Bradley 6 Rack Digital Smoker 240V

Bradley Technologies Canada Inc.
8380 River Road, Delta, BC, Canada V4G 1B5
Canada 1-800-665-4188 USA 1-866-508-7514
info@bradleysmoker.com
www.bradleysmoker.com

Printed in China
2011

Dear Sir or Madam,

“Revolutionary Smoking Technology for Household Chefs”

Welcome to the wonderful experience of backyard smoking and slow roast cooking. The Bradley Smoker is an insulated smoker oven designed to automatically generate a continuous flow of clean smoke. It is an outdoor electrical appliance that enables one to cook, roast, hot smoke, as well as cold smoke food with consistently superior results using minimal effort.

The Bradley Smoker is unique in that it produces smoke which is four times cleaner than traditional burn-box chips*. Because it automatically extinguishes the spent Bisquette, it prevents the formation of high temperature gases and acids. In addition, the Bradley Smoker meets both North American and European appliance standards.

There are nine different woods of the Bradley Flavor Bisquettes that are made especially for your smoker - Alder, Apple, Cherry, Hickory, Maple, Mesquite, Oak, Pecan and Special Blend. There are a number of recipe cards that come packaged with the Bradley Flavor Bisquettes which are also available in the Bradley Recipe Collection, Volume One. Other items of interest are the Flavor Cures, Bradley Jerky Racks, Bradley Original Racks, Sausage Hooks, Weather Guard Covers, Bradley Cooking DVD, Caps, Aprons, and the Bradley Digital Thermometer with meat probe that takes all the guesswork out of roasting and smoking meat.

I wish you great cooking and smoking for the years to come.

Sincerely,

A handwritten signature in black ink, appearing to read 'Wade Bradley', with a stylized flourish at the end.

Wade Bradley

**Based on studies and tests performed at The British Columbia Institute of Technology.*

Important Safety Warnings

Basic Safety Precautions

- Read all instructions.
- Do not touch hot surfaces. Use handles or knobs.
- To protect against electric shock, do not immerse cord or plugs in water or other liquids.
- Close supervision is necessary when any appliance is used by or near children.
- Unplug from outlet when not in use and before cleaning. Allow to cool before putting on or taking off parts.
- Do not operate any appliance with a damaged cord or plug or after the appliance malfunctions or has been damaged in any manner.
- The use of accessory attachments is not recommended by the appliance manufacturer. May cause injuries.
- Do not modify your smoker from its original state.
- Do not let cord hang over edge of table or counter, or touch hot surfaces.
- Do not place on or near a hot gas or electric burner or in a heated oven.
- Extreme caution must be used when moving an appliance containing hot oil or other hot liquids.
- Always attach plug to appliance first, then plug into the wall outlet. To disconnect, turn all controls to “off”, then remove plug from wall outlet.
- Do not use appliance for other than intended use.
- Save these instructions.
- For household use only.
- Lift and move smoker with care to prevent strains and back injuries.
- Use caution when reaching into or around smoker.
- It is recommended that a fire extinguisher be placed near the smoker. Refer to your local authority to determine proper size and type of fire extinguisher.
- If an extension cord is required, the cord must be an approved 3-prong (grounded) heavy duty cord not over 6 feet long.
- A short detachable power supply cord should be used to reduce the risk resulting from becoming entangled in or tripping over a longer cord.
- Longer detachable power supply cords are available and may be used if care is exercised

in their use.

- The extension cord should be a grounding type 3-wire cord.
- The marked electrical rating of the cord set or extension cord should be at least as great as the electrical rating of the appliance.
- The cord should be arranged so that it will not drape over the countertop or tabletop where it can be pulled on by children or tripped over unintentionally.
- Outdoor extension cords should be used with outdoor use products and are surface marked with the suffix letter “W” and with a tag stating “Suitable for use with outdoor appliances”.
- Risk of Electric Shock. Keep extension cord connection dry and off the ground.
- Do not expose to rain.
- Do not use any other type of wood other than Bradley Flavor Bisquettes®.
- Properly dispose of all packaging.
- Use caution when assembling, operating, handling or cleaning your smoker as some edges on the metal parts may be sharp.

When in Use

- For semi-outdoors use only. Do not operate in an enclosed area.
- Do not leave unattended.
- Do not plug in the smoker until it is fully assembled.
- Do not cover or seal the racks or drip tray with aluminum foil. This can cause severe damage to your smoker
- Do not move smoker.
- Do not exceed a temperature of 280°F.
- Always wear oven mitts or gloves to protect hands from burns.
- Do not wear loose clothing or allow hair to hang freely.
- Do not use packaging box to cover the smoker.
- Use only approved grounded electrical outlet.
- Do not allow rainwater to come in contact with smoker at any time. Place unit under center of 3 x 3 x 2.5m shelter.

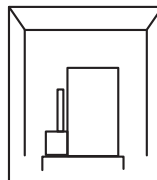

(Continued on next page)

“Carefully read through Assembly Instructions to prepare smoker for use”

When in Use (cont.)

- Do not use during an electrical storm or in windy conditions.
- Do not use near gasoline or other flammable liquids, gases, or where flammable vapors may be present.
- Place in an area where children and pets cannot access.
- Do not immerse in water.
- Empty drip bowl every 2 to 3 hours of burnt wood bisquettes and refill with fresh water.

After Each Use

- Unplug smoker when it is not in use. See Maintenance Procedures.
- Place extinguished Bradley Flavor Bisquettes® at a safe distance from all structures and combustible materials.
- Store the smoker in a dry covered place out of reach of children.
- Clean out any grease. Grease build up may cause fire.

General Maintenance

Refer to the External Components List & Internal Components List Diagrams

Important Safety Precautions

- The Bradley Smoker must be maintained and cleaned after each use.
- Unplug the Long Power Cord prior to commencement of any maintenance or cleaning.
- Do not immerse smoker in water.
- Do not spray inside of smoker with any kind of appliance cleaner.
- Do not cover or seal the racks or drip tray with aluminum foil. This can cause severe damage to your smoker.
- Do not leave unattended when in use.
- Do not spray or clean the smoker with excessive amounts of water. Instead use a damp cloth.

Maintenance Procedures

- Use caution when handling and cleaning your smoker as some metal edges may be sharp.
- Clean out the Drip Bowl. Dispose of all burnt Bisquettes carefully as they may still be hot.
- Wash the Drip Tray, Racks, Bottom Rectangular Tray and Drip Bowl with hot water and dish detergent or put them in the dishwasher.
- Remove food particles and grease residue from the smoker. If the inside needs cleaning, wipe it with a damp cloth.

Note: *The tower should have smoke or black residue on the inside. The more residue, the better the product will taste.*

- The Smoke Generator should be kept clean and free of wood chips and grease at all times. If loose wood chips have collected in the Smoke Generator, simply blow or vacuum these particles away. Unplug the Long Power Cord before removing the Smoke Generator from the Smoke Tower. Refer to “Remove Smoke Generator” in “Assembly Instructions”.
- The Bisquette Burner should be lightly scraped using a wire brush or scraper to remove any residue that has been left by the burning process.
- Clean the Damper (at the top of the Smoker) to ensure it is not stuck.
- Wipe the Door Seal with warm water and dish detergent to remove any leftover residues and food particles.

After Cleaning

- Replace Racks, Drip Tray, Bottom Rectangular Tray and Drip Bowl into the smoker, making sure all parts are clean and dry.
- Insert the Smoke Generator back into the Smoke Tower.
- Make sure the Long Power Cord is unplugged.

Trouble Shooting

No Power to Smoker:

Check that all plugs are correctly and firmly inserted into sockets. Check fuse (located on smoke generator). Check to make sure the outlet, Ground Fault Circuit Interrupter (GFCI), has not been tripped.

Bisquettes will not Advance:

Check the drive guide and clear all loose wood chips. By cleaning the smoke generator, bisquette jamming and undue wear and tear can be avoided.

Bisquette does not Burn Completely:

Check to see if other electrical equipment is plugged into the circuit. The smoker should be plugged into its own dedicated wall circuit. Check to make sure the bisquette burner is free of residue build up.

Smoker Oven Not Reaching Temperatures:

Allow smoker oven time to preheat. Remember, once food is put in the oven, the temperature will drop, and slowly rise again. Try closing the Damper slightly and keeping the smoker out of the wind. Next, try using a separate thermometer inside the smoker oven to ensure the temperature is reading correctly.

Note- Normal cooking temperature is between 200° F – 250° F. Keep in mind that the Temperature shown on the Display is for reference only and is not intended to give exact internal temperatures of the food. The internal temperature will be higher closer to the Heat Element.

If these tips don't work, please call our Customer Service at Canada 1-800-665-4188 or USA 1-866-508-7514

Assembly Instructions

The Black Bradley Smoker (Models: BTIS1; BTISCE240EU)

For The Original Bradley Smoker See Page 9 For 4 and 6 Rack Digital Smokers See Page 13

Refer to Part Numbers in the Bradley Smoker External Components List and Internal Components List Diagrams

How to Assemble the Bradley Smoker®

1. Remove smoker from box.
2. Take all packaged parts out of smoker.
3. Remove all protective packaging materials from parts.

Install Smoke Generator:

- Attach smoke generator (1) to the smoker tower (2).
- Aim the bisquette burner (F) toward the tower opening.
- Align smoke generator key holes to smoker tower locating supports (3).
- Secure the generator by pushing down firmly.
- Insert the feeder tube (4) on top of the smoke generator and push down firmly then load it with the desired number of Bradley Flavor Bisquettes®.
- Plug the short power cord (E-not shown) from the smoke generator into the smoker tower.

Set Up Smoker Tower:

- Place Racks (C) onto side supports.
- Place Drip Tray (B) “V” facing down beneath the Racks on the brass side pins.

- Place the Rectangular Tray (J) on the bottom of the Smoker.
- Fill the Drip Bowl (D) half full of water and place in the center of the Rectangular Tray to catch burnt Bisquettes. During a long smoking period, the Drip Bowl will require changing the water every 2-3 hours. Plug the Long Power Cord (A) for the smoke generator into an approved grounded electrical outlet.

To Remove Smoke Generator:

- Unplug short jumper cord (E).
- Detach smoke generator from the smoker tower by raising the smoke generator gently upward and pull it outward.

Handling of Packaging

All packaging should be discarded as per the regulations in your area. The box can be used only to store smoker when not in use. The box should not be used as a cover when smoker is in use.

The Black Bradley Smoker®

BTIS1 and BTISCE240EU

External Components List

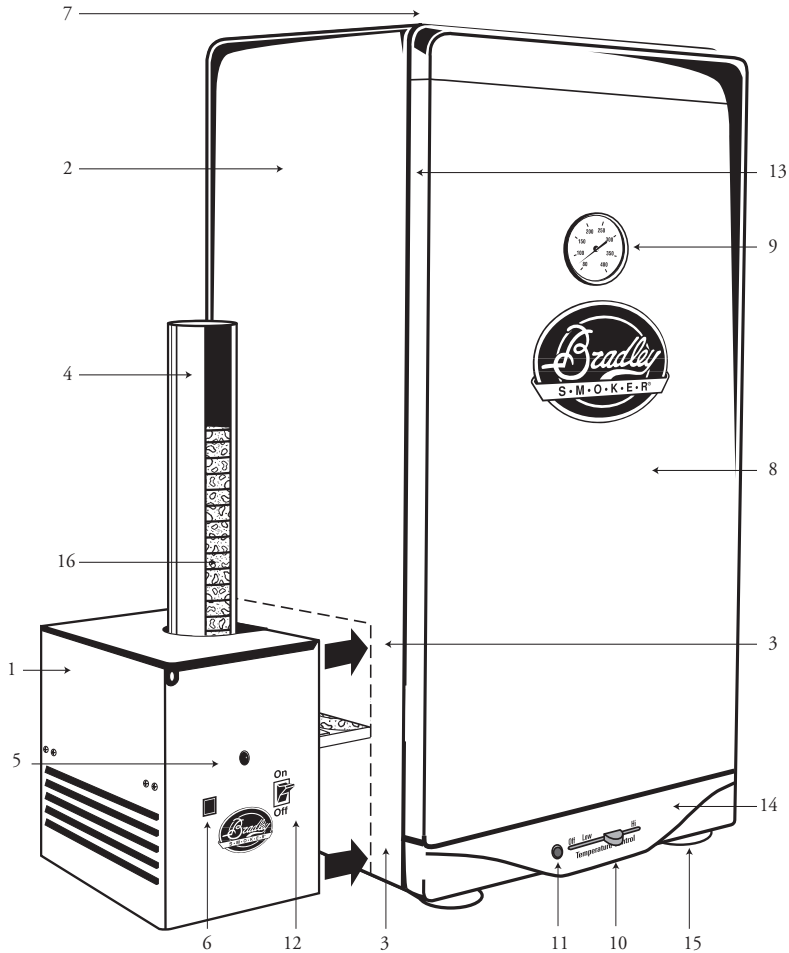

External Parts List

- | | |
|------------------------------------|---|
| 1. Smoke Generator | 9. Thermometer |
| 2. Smoker Tower | 10. Temperature Heat Control Switch |
| 3. Generator Supports | 11. Heat Indicator |
| 4. Feeder Tube | 12. Generator On/Off Switch |
| 5. Smoke Generator Indicator Light | 13. Door Seal |
| 6. Bisquette Advance Button | 14. Lower Face Plate |
| 7. Damper with handle (not shown) | 15. Rubber Feet |
| 8. Door | 16. Bisquette (not included with smoker). |

The Black Bradley Smoker®

BTIS1 and BTISCE240EU

Internal Components List

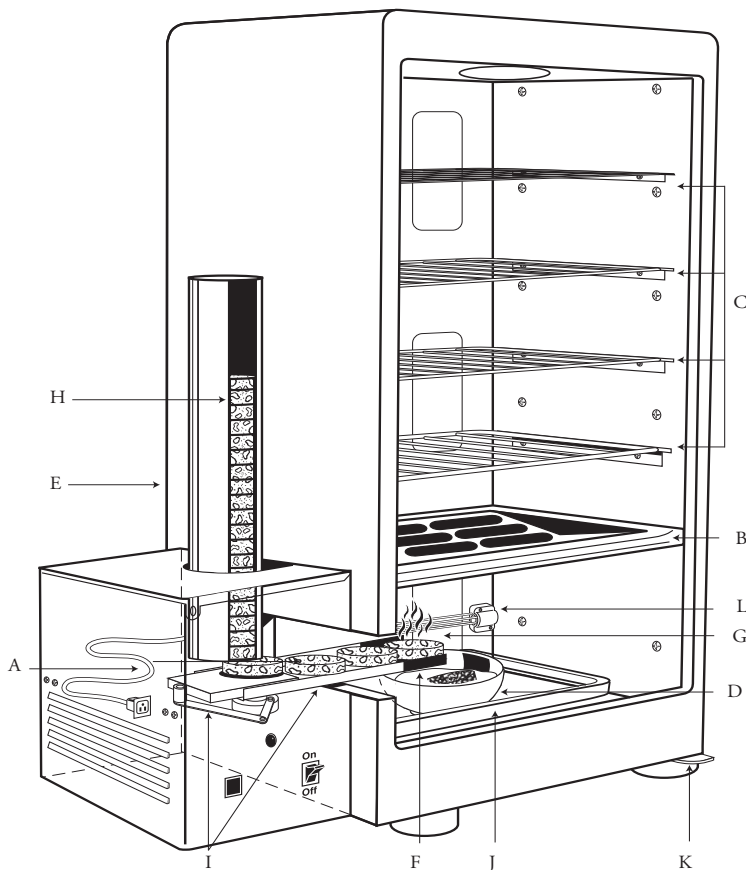

Internal Parts List

- | | |
|--|--------------------------------------|
| A) Long Power Cord | G) 500 Watt Heating Element |
| B) Drip Tray | H) Flavor Bisquettes® (not included) |
| C) Cooking Racks | I) Drive Guide |
| D) Drip Bowl | J) Bottom Rectangular Tray |
| E) Short Jumper Cord (not shown)
Connects Generator | K) Door Hinge |
| F) Bisquette Burner | L) Porcelain Holder |

Operating Guidelines

for the BTIS1 and BTISCE240EU - The Black Bradley Smoker

Refer to part numbers in the External Components List Diagram

Seasoning & Preparation For Use

Seasoning the Bradley Smoker® is an ongoing process, the more you use it, the better tasting your foods will be.

Seasoning is mainly to remove the impartial smells from your smoker. The smell of your new Bradley Smoker® is not necessarily how you want your food to taste.

Seasoning Method:

- Clean Racks, Drip Tray, Drip Bowl and Rectangular Tray and place in smoker.
- Fill the Drip Bowl half full of water.
- Load the Feeder Tube with 5 Bisquettes. (note: each Bisquette burns for 20 minutes). The 2 extra Bisquettes are meant to push the final Bisquette onto the Burner. These last 2 Bisquettes will not advance onto the Burner.
- Open the damper slightly at the top of the Smoker Tower.
- Plug smoker into its own designated outlet.
- Turn on the smoke generator by pressing the Generator On/Off Switch (12).
- Pre-heat Bisquette Burner for 20 minutes.
- Press Bisquette Advance Button (6) until a bisquette is on the Bisquette Burner (F).
- Turn on the smoker by moving the temperature heat control switch (10) to medium. Wait for 20 to 30 minutes. The thermometer (9) should read 66°C (150°F). If it is higher, bring down the temperature by adjusting the temperature heat control switch to the left to lower and vice versa when the temperature reads lower than 66°C (150°F).
- Smoke the tower continuously at 66°C (150°F) for 1 hour, or until bisquettes are out.
- Your Smoker will be seasoned having reached 150° F and smoked in for 1 hour.

Getting Started

- After seasoning the smoker, refill the Drip Bowl half full of water.
- Turn on the Smoke Generator by pressing the Generator On/Off switch (12) this pre-heats the Bisquette burner.
- When the Smoker Generator indicator light (5) is on, this means the Generator has power.
- Press the bisquette advance button (6) to push a Bisquette onto the Bisquette burner (F). Note: After the advance button has been pressed, a new cycle will start, (or) in approximately 20 minutes the next bisquette will advance.
- Pre-heat oven to the desired temperature you want to cook at.
- Place your food onto the cooking racks and load them into the smoker.
- Set the damper at the desired opening. Do not close the damper all the way when the smoke is running.
- You may need to adjust the Heat Control Switch to reach the desired temperature as per the door thermometer.

Cold Smoke - use the smoke generator only. Unplug the Short Jumper Cord.

Hot Smoke - the smoke generator and temperature heat control switch will be on.

Note: The thermometer will only read the air temperature inside the tower. To get a more accurate temperature of the food being smoked, use a meat thermometer. Keep in mind that the ambient temperature will affect the cooking temperature of the smoker.

“ Remember to clean your smoker after each use.”

Assembly Instructions

The Original Bradley Smoker (Model: BS611; BS611EU)

For The Black Black Smoker See Page 5 For 4 and 6 Rack Digital Smokers See Page 13

Refer to Part Numbers in External Components List, Internal Components List and Electrical Connection Set Up

How to Assemble The Original Bradley Smoker®

1. Remove smoker from box.
2. Take all packaged parts out of smoker.
3. Remove all protective packaging materials from parts.

Install Smoke Dial Generator:

- Attach smoke dial generator (1) to the smoker tower (2).
- Aim the bisquette burner (F) toward the tower opening.
- Align smoke dial generator key holes to smoker tower locating supports (3).
- Secure the smoke dial generator by pushing down firmly.
- Insert the feeder tube (4) on top of the smoke dial generator and push down firmly then load it with the desired number of Bradley Flavor Bisquettes®.
- Plug the short power cord (E-not shown) from the smoke dial generator into the smoker tower.

Set Up Smoker Tower:

- Place Racks (C) onto side supports.
- Place Drip Tray (B) “V” facing down beneath the Racks on the brass side pins.

- Place the Rectangular Tray (J) on the bottom of the Smoker.
- Fill the Drip Bowl (D) half full of water and place in the center of the Rectangular Tray to catch burnt Bisquettes. During a long smoking period, the Drip Bowl will require changing the water every 2-3 hours.
- Plug the Long Power Cord (A) for the smoke generator into an approved grounded electrical outlet.

To Remove Smoke Dial Generator:

- Unplug short jumper cord (E).
- Detach smoke dial generator from the smoker tower by raising the smoke dial generator gently upward and pull it outward.

Handling of Packaging

All packaging should be discarded as per the regulations in your area. The box can be used only to store smoker when not in use. The box should not be used as a cover when smoker is in use.

The Original Bradley Smoker®

BS611 and BS611EU

External Components List

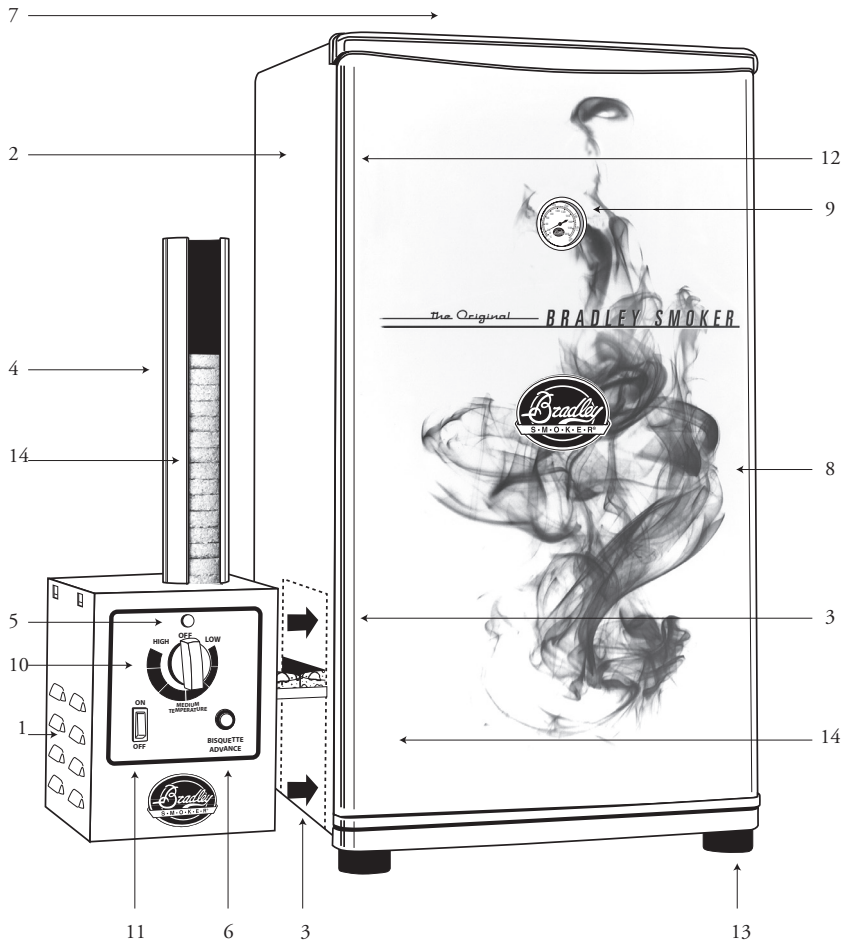

External Parts List

- | | |
|------------------------------------|--|
| 1. Smoke Dial Generator | 8. Door |
| 2. Smoker Tower | 9. Thermometer |
| 3. Generator Supports | 10. Temperature Heat On/off Control Dial |
| 4. Feeder Tube | 11. Generator On/Off Switch |
| 5. Smoke Generator Indicator Light | 12. Door Seal |
| 6. Bisquette Advance Button | 13. Rubber Feet |
| 7. Damper with handle (not shown) | 14. Bisquette (not included with smoker) |

The Original Bradley Smoker®

BS611 and BS611EU

Internal Components List

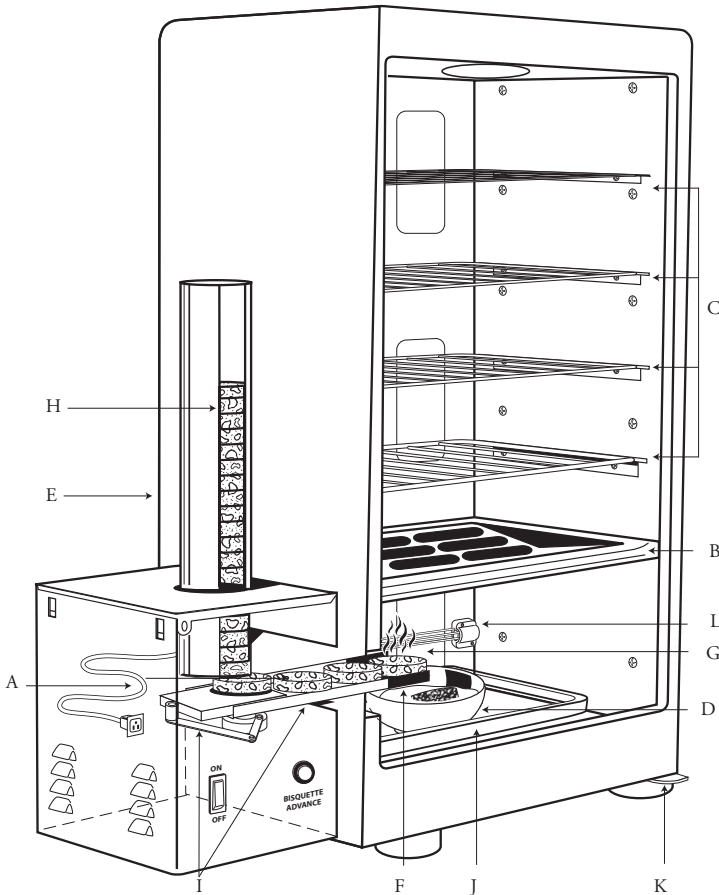

Internal Parts List

- | | |
|---------------------------------|--------------------------------------|
| A) Long Power Cord | G) 500 Watt Heating Element |
| B) Drip Tray | H) Flavor Bisquettes® (not included) |
| C) Cooking Racks | I) Drive Guide |
| D) Drip Bowl | J) Bottom Rectangular Tray |
| E) Short Power Cord (not shown) | K) Door Hinge |
| Connects Generator | L) Porcelain Holder |
| F) Bisquette Burner | |

Operating Guidelines

for the BS611 and BS611EU - The Original Bradley Smoker

Refer to part numbers in the External Components List Diagram

Seasoning & Preparation For Use

Seasoning the Bradley Smoker® is an ongoing process, the more you use it, the better tasting your foods will be.

Seasoning is mainly to remove the impartial smells from your smoker. The smell of your new Bradley Smoker® is not necessarily how you want your food to taste.

Seasoning Method:

- Clean Racks, Drip Tray, Drip Bowl and Rectangular Tray and place in smoker.
- Fill the Drip Bowl half full of water.
- Load the Feeder Tube with 5 Bisquettes. (note: each Bisquette burns for 20 minutes). The 2 extra Bisquettes are meant to push the final Bisquette onto the Burner. These last 2 Bisquettes will not advance onto the Burner.
- Open the damper at the top of the Smoker Tower.
- Plug smoker into its own designated outlet.
- Turn on the smoke generator by pressing the Generator On/Off Switch (11).
- Pre-heat Bisquette Burner for 20 minutes.
- Press Bisquette Advance Button (6) until a bisquette is on the Bisquette Burner (F).
- Turn on the smoker by rotating the temperature heat on/off control dial (10) to medium (about the 6 o'clock position). Wait for 20 to 30 minutes. The thermometer (9) should read 66°C (150°F). If it is higher, bring down the temperature by rotating the temperature heat on/off control dial to the 3 o'clock position and vice versa until the temperature reads 66°C (150°F).
- Smoke the tower continuously at 66°C (150°F) for 1 hour, or until bisquettes are out.
- Your Smoker will be seasoned having reached 150° F and smoked in for 1 hour.

Getting Started

- After seasoning the smoker, refill the Drip Bowl half full of water.
- Turn on the Smoke Generator by pressing the Generator On/Off switch (11) this pre-heats the Bisquette burner.
- When the Smoker Generator indicator light (5) is on, this means the Generator has power.
- Press the bisquette advance button (6) to push a Bisquette onto the Bisquette burner (F). Note: After the advance button has been pressed, a new cycle will start, (or) in approximately 20 minutes the next bisquette will advance.
- Pre-heat oven to the desired temperature you want to cook at.
- Place your food onto the cooking racks and load them into the smoker.
- Set the damper at the desired opening. Do not close the damper all the way when the smoke is running.
- You may need to adjust the Heat On/off Control Dial to reach the desired temperature as per the door thermometer.

Cold Smoke - use the smoke generator only. Unplug the Short Power Cord.

Hot Smoke - the smoke generator and temperature heat on/off control dial will be on.

Note: The thermometer will only read the air temperature inside the tower. To get a more accurate temperature of the food being smoked, use a meat thermometer. Keep in mind that the ambient temperature will affect the cooking temperature of the smoker.

“Remember to clean your smoker after each use.”

Assembly Instructions

4 Rack Digital Smoker (Model: BTDS76P; BTDS76CE-EU)

6 Rack Digital Smokers (Model: BTDS108P; BTDS108CE-EU)

For Original Bradley Smoker Assembly Instructions See Page 9

Refer to Part Numbers in External Components List, Internal Components List and Electrical Connection Set Up

How to Assemble the Bradley Digital Smoker®

1. Remove smoker from box.
2. Take all packaged parts out of smoker.
3. Remove all protective packaging.

Install Digital Smoke Generator:

- Attach digital smoke generator (1) to the smoker tower (2) by placing the Bisquette Burner (E) through the left side opening of the tower. Align the generator keyholes to the two supports (3) on the side and push down to secure in position.
- Insert the feeder tube (4) into the top of the smoke generator. Push down firmly. Load with desired number of Bradley Flavor Bisquettes®.

Electrical Connection Set Up (see page 16)

- Plug the Sensor Cable (1) into the back of the Smoke Generator Sensor Receptacle (A) and Smoker Tower Sensor Receptacle (B).
- Plug the Short Power Cord (2) into the back of the Smoke Generator Female Receptacle (D) and then into the back of the Smoker Tower Male Receptacle (C) - push firmly.

- Plug the Long Power Cord (3) into the power receptacle (E).

Set Up Smoker Tower:

- Place Racks, either four or six (B) onto side supports.
- Place Drip Tray (A) “V” facing down beneath the Racks on the brass side pins and under pin (I).
- Place the Rectangular Tray (D) on the bottom of the Smoker.
- Fill the Drip Bowl (C) half full with water and place in the center of Rectangular Tray (D) to catch burnt Bisquettes. During a long smoking period, the Drip Bowl will require changing the water.
- Plug the Long Power Cord (3) from the Smoke Generator into an approved grounded electrical outlet (4). (see page 16)

To Remove Smoke Generator (see page 16)

- Make sure the Smoke Generator has had time to cool down. Unplug Long Power Cord (3) from the wall outlet (4) and from the Smoke Generator (E). Detach Sensor Cable (1) and Short Power Cord (2) and then remove Smoke Generator from the Smoker Tower by raising it gently upward and pulling it outward.

The Bradley Digital Smoker®

BTDS76P and BTDS76CE-EU
BTDS108P and BTDS108CE-EU

External Components List

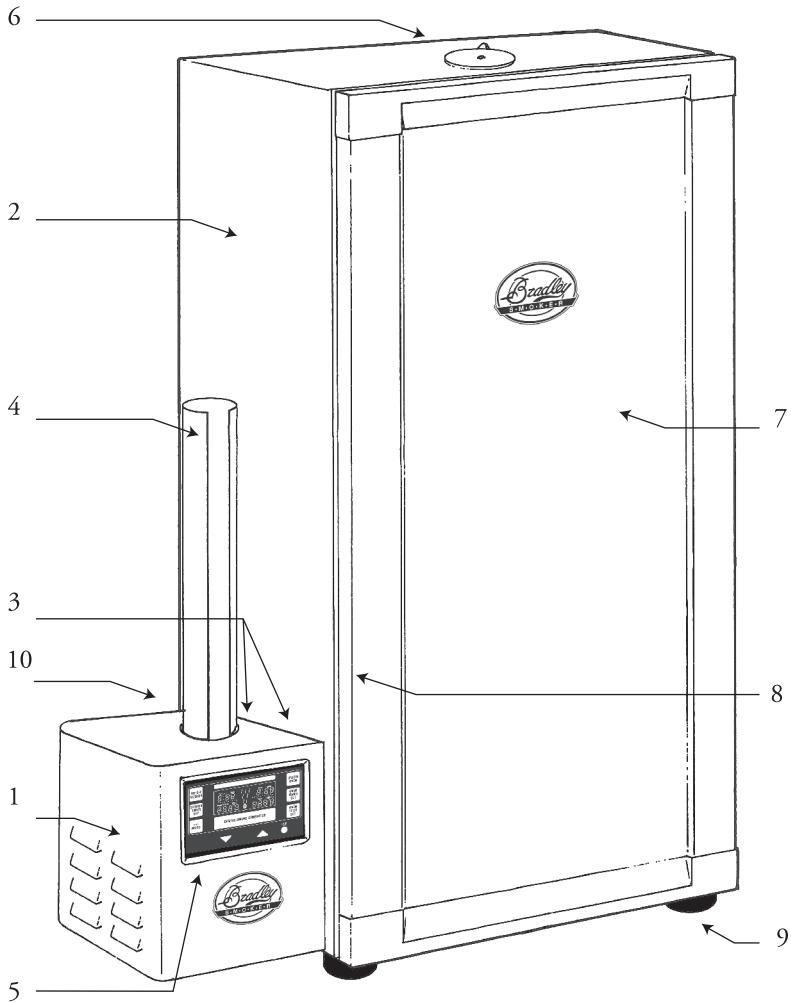

Exterior Parts List

- | | |
|--|--|
| 1. Digital Smoke Generator | 6. Damper |
| 2. Smoke Tower | 7. Door |
| 3. Generator Supports (not shown) | 8. Door Seal |
| 4. Feeder Tube | 9. Rubber Feet |
| 5. Digital Display Panel (see page 17) | 10. Sensor Cable, Short Power Cord &
Long Power Cord (not shown, see page 16) |

The Bradley Digital Smoker®

BTDS76P and BTDS76CE-EU

BTDS108P and BTDS108CE-EU

Internal Components List

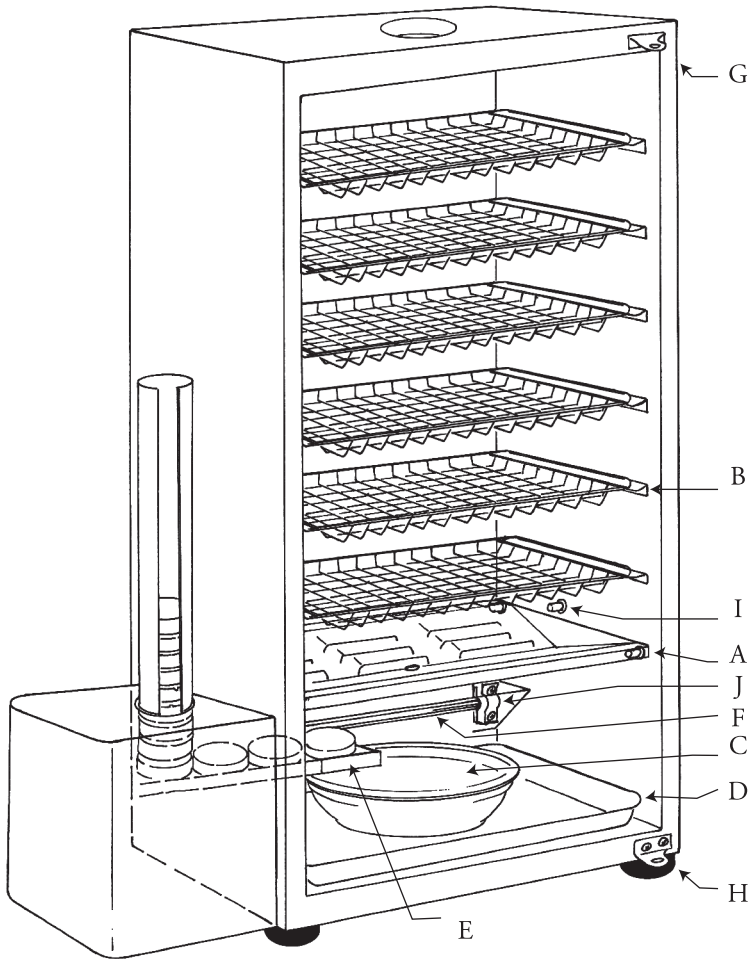

Internal Parts List

- | | |
|--|------------------------|
| A) Drip Tray | F) Heating Element |
| B) Cooking Racks (4 or 6) | G) Top Door Hinge |
| C) Drip Bowl | H) Lower Door Hinge |
| D) Bottom Rectangular Tray | I) Brass Pin |
| E) Bisquette Burner
(Bisquettes not included) | J) Porcelain Insulator |

ELECTRICAL CONNECTION SET UP

After mounting Generator on side of Smoker

(IN THIS ORDER)

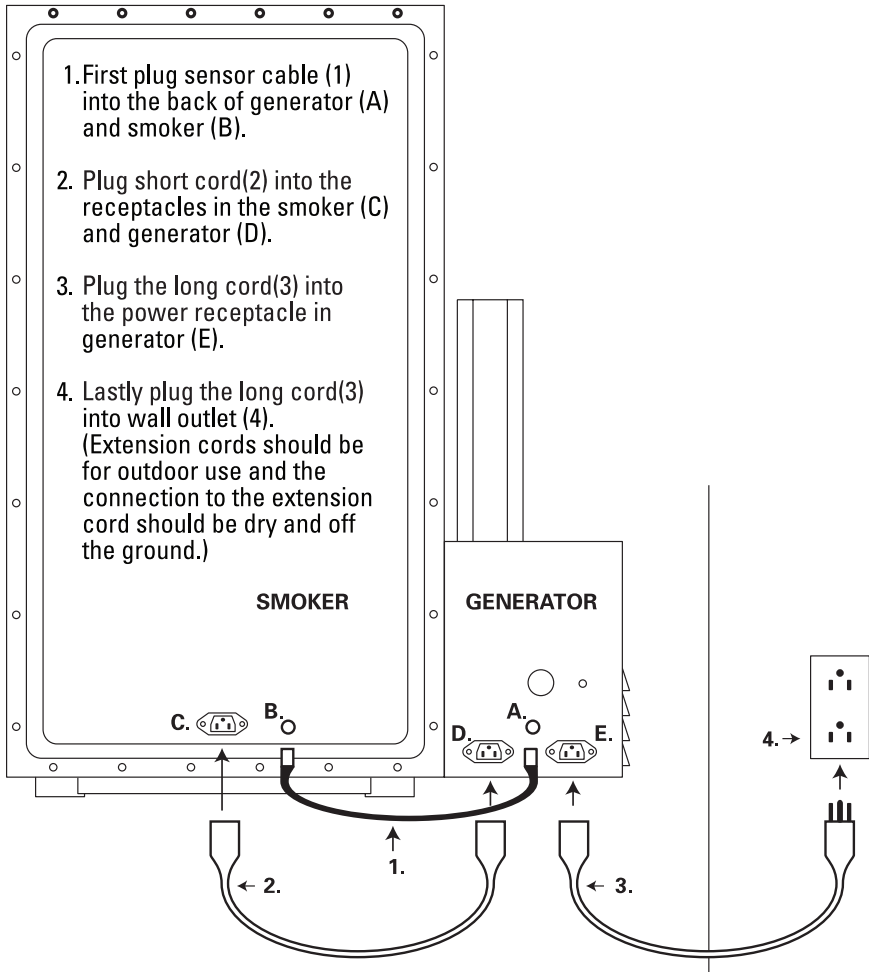

1. Sensor Cable
2. Short Power Cord
3. Long Power Cord
4. Wall Outlet

- A. Sensor Receptacle
- B. Sensor Receptacle
- C. Male Receptacle
- D. Female Receptacle
- E. Male Receptacle

Display Function Guideline

Digital Smoke Generator

- Smoke Generator operated by left side control buttons.
- Press **“On/Off Smoker”** to turn Smoke Generator on.
- Press **“>>> Wood”** to advance Bisquettes onto Burner. Each press advances Bisquette one spot.
- Press **“Smoker Timer Set”** and then “v ^” to desired length of smoking time.
- Press **“Smoker Timer Set”** again to start 20 minute automatic advance.
- Press **“On/Off Smoker”** to turn Smoke Generator off.

Smoker Oven

- Smoker Oven operated by right side control buttons.
- Press **“On/Off Oven”** to turn Smoker Oven on.
- Press **“Oven Temp Set”** and then use “v ^” buttons to set desired temperature.
- Press **“Oven Temp Set”** again to set the temperature.
- Press **“Oven Timer Set”** and then use “v ^” to reach desired length of cooking time.
- Press **“Oven Timer Set”** again to set cooking time.
- Press **“On/Off Oven”** to turn Smoker Oven off.

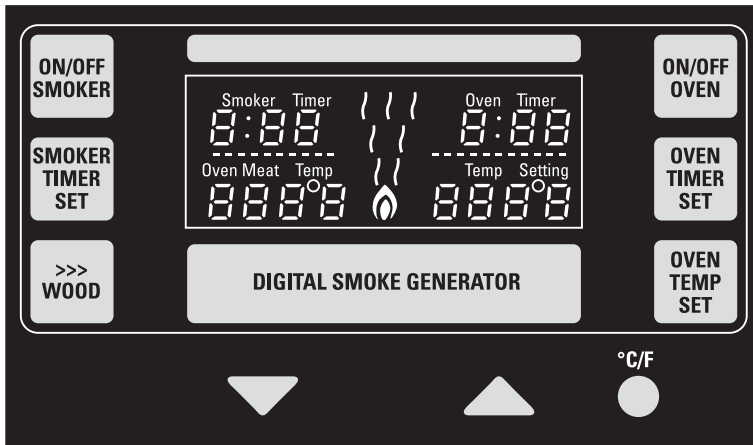

Display Function

Once the **“On/Off Smoker”** button has been pressed to turn the smoke generator on, the **“Smoker Timer”** display will flash until the desired time has been set. The **“Oven Temp”** will start to read the internal temperature right away. Once the **“On/Off Oven”** button has been pressed to turn the oven on, the **“Oven Timer”** display will flash until the desired cooking time has been set. The **“Temp Setting”** will also flash until the desired temperature has been set.

Press the C/F Button to change the setting from Celsius to Fahrenheit.

Operating Guidelines

for the BTDS76P, BTDS76CEEU, BTDS108P and BTDS108CEEU - The Bradley Digital Smoker

Refer to part numbers in the External Components List Diagram

Seasoning & Preparation For Use

- Seasoning the Bradley Digital Smoker is an ongoing process, the more you use it, the better tasting the foods will be.
- The Seasoning Process is mainly to remove the impartial smells and flavors from your smoker. The smell of your new Bradley Digital Smoker is not necessarily how you want your food to taste.

Seasoning Method

- Clean Racks, Drip Tray, Drip Bowl and Rectangular Tray and place in smoker.
- Fill the Drip Bowl half full of water.
- Load the Feeder Tube with 5 Bisquettes. Note- Each Bisquette burns for 20 minutes. The 2 extra Bisquettes are meant to push the final Bisquette onto the Burner. These last 2 Bisquettes will not advance onto the Burner.
- Open the Damper slightly at the top of smoker tower.
- Press **“On/Off Smoker”** to turn on.
- Pre-heat the Bisquette Burner for 20 minutes.
- Press **“>>>Wood”** to advance a Bisquette onto the burner.
- Set the **“Smoker Timer Set”** for 1 hour.
- Press **“On/Off Oven”** to turn on.
- Set **“Oven Temp Set”** to 150° F (66° C).
- Set the **“Oven Timer Set”** to 1 hour.

Note: Your smoker will be seasoned having reached 150° F and smoked in for 1 hour.

Getting Started (see *“Display Function Guideline”*)

- After seasoning the smoker, refill the Drip Bowl half full with water.
- Load desired amount of Bisquettes into the Feeder Tube.
- Press the **“On/Off Smoker”** to turn the smoke generator on.
- Pre-heat the Bisquette Burner for 20 minutes.
- Press **“>>>Wood”**. Allow time for Bisquette to advance. Repeat this step twice to move a Bisquette onto the burner.
- Press **“Smoker Timer Set”** for length of smoking time.
- Set the Damper to the desired opening. Do not close damper all the way when smoke is running.
- Press the **“On/Off Oven”** to turn smoker oven on.
- Pre-heat the Smoker Oven to the desired temperature you want to cook at.
- Press **“Oven Temp Set”** to set the heat.
- Press **“Oven Timer Set”** to set length of cooking time.
- Place your food onto the Racks and load them into the smoker.
- Empty Drip Bowl every 2 to 3 hours of burnt wood Bisquettes and refill with fresh water.
- Cold Smoke - Use the generator only. Unplug the Short Power Cord (2).
- Hot Smoke - Use the generator and the oven together.

Note: The Digital Display will only read the air temperature inside the tower. To get a more accurate temperature of the food being smoked, use a meat thermometer. Keep in mind that the ambient temperature will affect the cooking temperature of the smoker.

“Remember to clean your smoker after each use.”

WARRANTY

The Bradley Smoker carries with it a 1 year limited warranty against manufacturing defects.

Requirements and Limitations:

Warranty is effective from the date of purchase. Keep your sales receipt as proof of purchase date.

Warranty is limited to repair or replacement of part as determined by Bradley Technologies Inc.

Bradley Technologies at its discretion will provide a replacement part for any component found by Bradley Technologies to be defective and shall not be responsible for any re-assembly.

This limited warranty is non-transferable and becomes void if product is used for commercial or rental purposes.

Warranty covers manufacturer's defects only.

This limited warranty will not reimburse you for the cost of any inconvenience, food, personal injury or property damage.

Warranty is valid only in the country of purchase.

Shipping and handling charges are the responsibility of the original consumer/purchaser for all out of warranty parts orders.

Serial number of the smoker must be provided on all warranty claims.

Bradley Technologies excludes from its warranty the following:

Defects, damage resulting from accident, abuse, misuse, alteration, improper assembly /installation and vandalism are not covered.

Damage resulting from weather conditions including but not limited to hail, hurricanes, tornados, earthquakes, wind, rain or snow are not covered.

Normal wear and tear, chipping and scratching on surface finishes is not covered.

Discoloration from exposure to sunlight, heat or chemicals is not covered by this warranty.

Failure to perform regular maintenance, safety checks and service including but not limited to; removal of grease build up resulting in a flash fire, damage caused by grease fires is not covered by this warranty.

To ensure your satisfaction
And for follow-up service, register your smoker online at:
www.bradleysmoker.com

For warranty and customer services please call:
Canada 800-665-4188 USA 866-5087514

