

# Weight Kit

## Zero-Turn-Radius Riding Mower

Model No. 131-7658

### Installation Instructions

## Loose Parts

Use the chart below to verify that all parts have been shipped.

Description	Qty.	Use
Bolt (3/8 x 1-1/4 inches)	4	Install the weight.
Locknut (3/8 inch)	4	
Weight mounting bracket, left	1	
Weight mounting bracket, right	1	
Washers	4	
Weight holding bracket	1	
Bolt (3/8 x 1 inch)	2	
Flat weight	1	
Suitcase weight	1	
Keyed cross bar	1	

## Installing the Weight

### ⚠ CAUTION

The attachment changes the weight distribution of the machine. Operating the machine without the front weights may cause an unstable condition which could result in a loss of control.

Ensure the front weights are properly installed before operating the machine with the attachment.

- Park the machine on a level surface, remove the key from the ignition switch, engage parking brake, let engine cool and disconnect the wire from the spark plug(s) before installing the attachment.
- Locate the forward bolts on the underside of the frame (Figure 1 and Figure 2). Remove the 2 bolts (3/8 x 1 inch) and 2 locknuts (3/8 inch). Retain the locknuts.

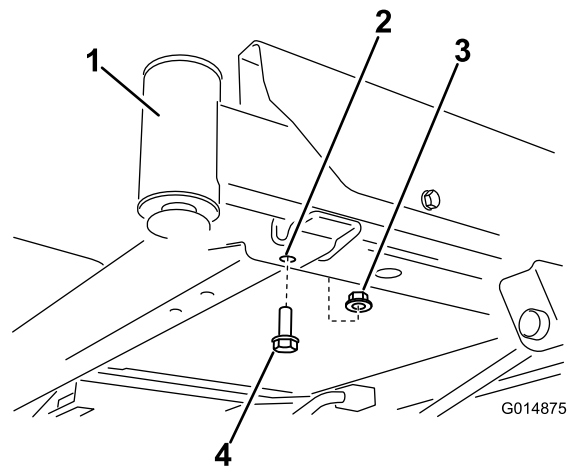
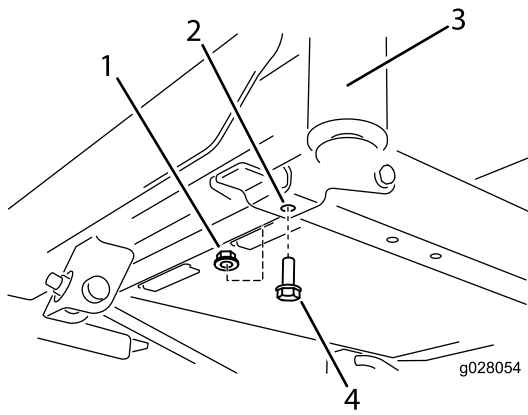

Figure 1

- Front right caster (caster fork and wheel not shown for clarity)
- Forward hole, right side
- Bolt (3/8 x 1 inch)
- Locknut (3/8 inch)





**Figure 2**

- |                            |  |
|----------------------------|--|
| 1. Locknut (3/8 inch)      | 3. Front left caster (castor fork and wheel not shown for clarity) |
| 2. Forward hole, left side | 4. Bolt (3/8 x 1 inch)   |

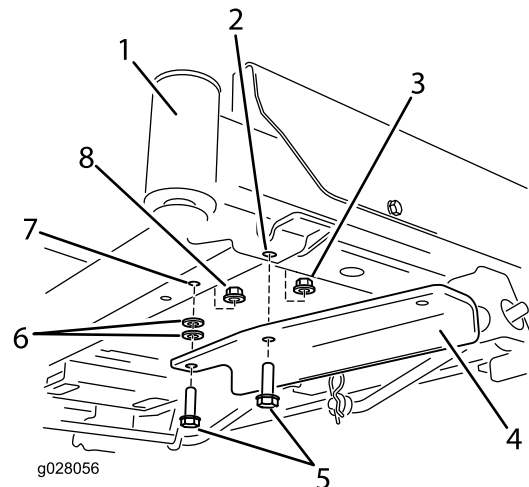

**Figure 4**

- |   |                                    |
|---|------------------------------------|
| 1. Front right caster (castor fork and wheel not shown for clarity) | 5. Bolt (3/8 x 1-1/4 inches)       |
| 2. Forward hole, right side   | 6. Washer                          |
| 3. Locknut (3/8 inch), existing                                     | 7. Hole, existing in frame         |
| 4. Right mounting bracket   | 8. Locknut (3/8 inch), loose parts |

3. Locate the left and right weight mounting brackets in loose parts. Start by installing the left bracket to the under side of the frame.
4. Secure the bracket to the frame using 2 bolts (3/8 x 1-1/4 inches), 2 washers and 2 locknuts (3/8 inch) (Figure 3). One locknut is from loose parts and the other is reused from earlier removal.

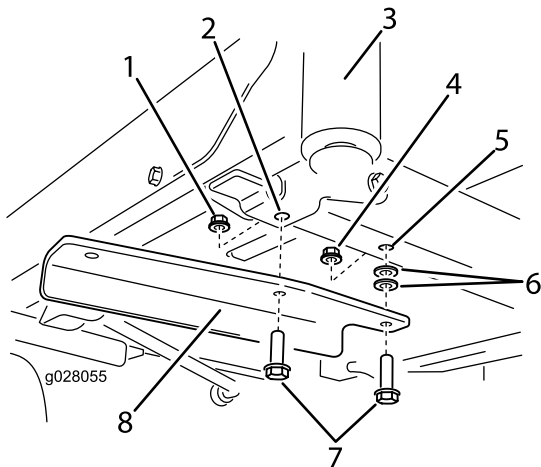

**Figure 3**

- |  |                              |
|--|------------------------------|
| 1. Locknut (3/8 inch), existing                                    | 5. Hole, existing in frame   |
| 2. Forward hole, left side   | 6. Washer                    |
| 3. Front left caster (castor fork and wheel not shown for clarity) | 7. Bolt (3/8 x 1-1/4 inches) |
| 4. Locknut (3/8 inch), loose parts                                 | 8. Left mounting bracket     |

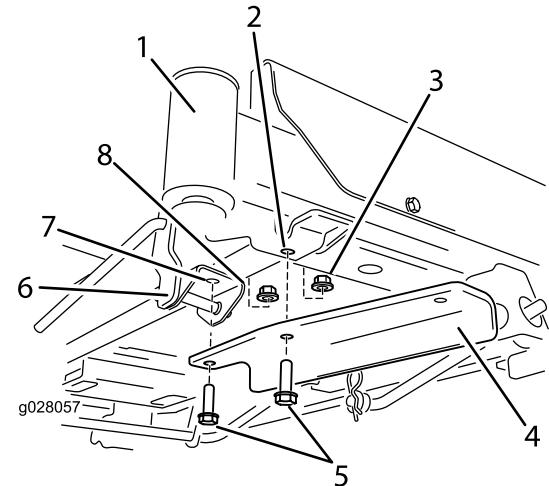
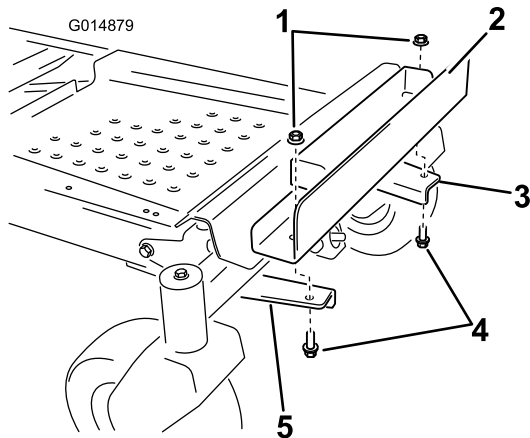

**Figure 5**

- |   |                                    |
|---|------------------------------------|
| 1. Front right caster (castor fork and wheel not shown for clarity) | 5. Bolt (3/8 x 1-1/4 inches)       |
| 2. Forward hole, right side   | 6. Foot assist lift pedal bracket  |
| 3. Locknut (3/8 inch), existing                                     | 7. Hole, existing in bracket       |
| 4. Right mounting bracket   | 8. Locknut (3/8 inch), loose parts |

5. On the right side of the machine install the right weight mounting bracket.
  - For machines without a foot assist lift pedal: secure the bracket using 2 bolts (3/8 x 1-1/4 inches), 2 washers and 2 locknuts (3/8 inch) (Figure 4). One locknut is from loose parts and the other is reused from earlier removal.

- Install the weight holding bracket to the mounting brackets (Figure 6). Align the inboard holes in the bracket with the mounting brackets installed previously. Make sure the bracket is centered on the frame. Secure with 2 bolts (3/8 x 1 inch) and 2 locknuts (3/8 inch).



**Figure 6**

- |                           |                           |
|---------------------------|---------------------------|
| 1. Locknut (3/8 inch)     | 4. Bolt (3/8 x 1 inch)    |
| 2. Weight holding bracket | 5. Right mounting bracket |
| 3. Left mounting bracket  |                           |

- Install a flat weight to the holding bracket and move it rearward, flush with the bracket (Figure 7).

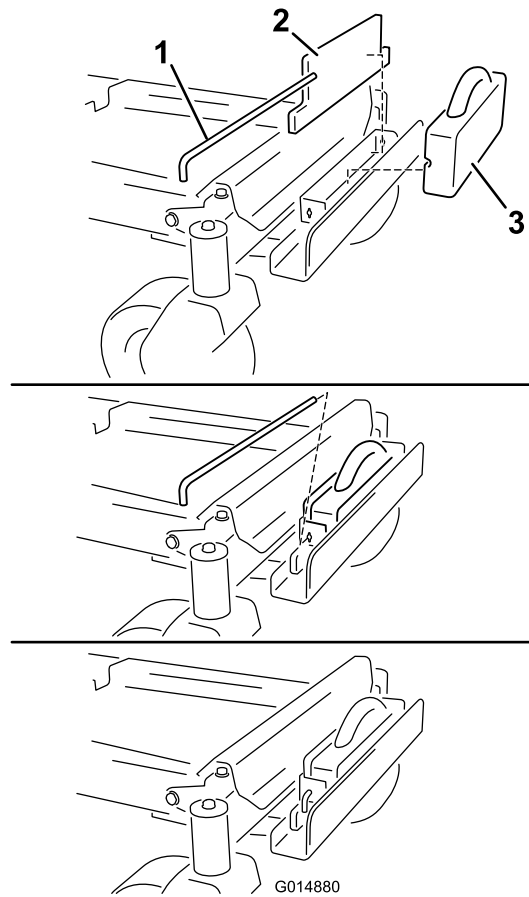

**Figure 7**

- |                    |                    |
|--------------------|--------------------|
| 1. Keyed cross bar | 3. Suitcase weight |
| 2. Flat weight     |                    |

- Install a suitcase weight in front of the flat weight (Figure 7). The groove in the suitcase weight should be facing rearward.
- Secure the weights to the bracket with a keyed cross bar (Figure 7). Install the bar and rotate it 90 degrees downward to lock it in place.
- Once all weights and brackets have been installed, go back and check that all fasteners are tight. Tighten as necessary.

**Important:** Whenever you remove the attachment, remember to remove the front weights to return the proper stability to the machine.

