

OWNER'S MANUAL



3-Burner Grill

Model # 3072



LP Gas Grill



A propane gas cylinder is required for operation. This gas grill is not intended for commercial use.

Keep your receipt with this manual for Warranty.

SAVE THESE INSTRUCTIONS FOR FUTURE REFERENCE. IF YOU ARE ASSEMBLING THIS UNIT FOR SOMEONE ELSE, GIVE THIS MANUAL TO HIM OR HER TO SAVE FOR FUTURE REFERENCE. FOR CUSTOMER SERVICE, CALL 912-638-4724

 **WARNING**
For Outdoor Use Only
(outside any enclosure)

WARNING:
Improper installation, adjustment, alteration, service or maintenance could cause injury or property damage. Read the installation, operation and maintenance instructions thoroughly before assembling or servicing this equipment.
Failure to follow these instructions could result in fire or explosion that could cause property damage, personal injury or death.

DANGER:
DO NOT use gas grill for indoor cooking or heating. TOXIC fumes can accumulate and cause asphyxiation. Do not use in or on boats or recreational vehicles.

PROP 65 WARNING:
Chemicals known to the state of California to cause cancer, birth defects or other reproductive harm are created by the combustion of propane.





If you smell gas:

1. Shut off gas to the appliance.
2. Extinguish any open flame.
3. Open Lid.
4. If odor continues, keep away from the appliance and immediately call your gas supplier or your fire department.



Do not store or use gasoline or other flammable liquids or vapors in the vicinity of this or any other appliance.

An LP cylinder not connected for use shall not be stored in the vicinity of this or any other appliance.

For Your Safety

Stop! Call us first! Do Not return product to store. This grill has been made to high quality standards. If you have any questions not addressed in this manual or if you need parts please call our customer service department at 1-912-638-4724 (USA), Monday-Friday 8:30am-5pm (EST).

Have your grills serial number (located on the back of the grill body or on the leg) when calling.

Page intentionally left blank for notes

Table of Contents

Important Safety Informationpage 5 - 6

Illustrated Parts Listpage 7 - 8

Tools, Assembly Tips and Hardware List ...page 9

Assembly Instructionspage 10–22

Operating Grill

Connecting Gas Cylinder.....page 24

Cleaning and Care.....page 25-26

Checking for Leaks.....page 27

Lighting Grill.....page 28-30

Trouble Shooting.....page 31-32

Grill Preparation.....page 33

Recipes.....page 34 - 35

Accessories.....page 36 - 37

WARNING

FOR YOUR SAFETY

1. DO NOT store or use gasoline or any other flammable vapors and liquids within 25 feet (8m) of this or any other appliance.
2. When cooking with oil/grease, do not allow the oil/grease to exceed 350 °F (177 °C). Do not store or use extra cooking oil in the vicinity of this or any other appliance.
3. An LP Cylinder not connected for use should be stored a minimum of 10 feet (3m) away from this or any other appliance. Never fill the cylinder beyond 80 percent full. If the above information not followed exactly, a fire causing death or serious injury may occur.
4. If you smell gas:
 - Shut Off gas to the grill.
 - Extinguish any open flame.
 - Open Lid

For Your Safety

Stop! Call us first! Do Not return product to store. This grill has been made to high quality standards. If you have any questions not addressed in this manual or if you need parts please call our customer service department at 1-912-638-4724 (USA), Monday-Friday 9am-5pm (EST).

NOTE: The use and installation of this product must conform to local codes. In absence of local codes, use the National Fuel Gas Code, ANSI Z223.1/NFPA54.

IMPORTANT NOTICE: read all instructions prior to assembly and use. Read and understand all warnings and precautions prior to operating your grill.

CAUTION

1. This grill is for use with propane gas only (propane gas cylinder not included).
2. Never attempt to attach this grill to the self-contained propane system of a camper trailer, motor home or house.
3. Never use charcoal or lighter fluid with the gas grill.
4. Do not use gasoline, kerosene or alcohol for lighting. The LP-gas supply cylinder must be constructed and marked in accordance with the specifications for propane gas cylinders of the U.S. Department of Transportation (DOT) CFR 49. This grill is not intended to be used in or installed on recreation vehicles and/or boats.
5. Do not attempt to move the grill while it is lit.
6. Do not use the grill unless it is completely assembled and all parts are securely fastened and tightened.
7. Keep all combustible items and surfaces at least 36 inches (91.4cm) away from grill at all times.
8. DO NOT use this grill or any gas product near unprotected combustible constructions.
9. Do not use in an explosive atmosphere. Keep grill area clear and free from combustible materials, gasoline and other flammable vapors and liquids.

10. Do not touch metal parts of grill until it has completely cooled (about 45 minutes) to avoid burns, unless you are wearing protective gear (BBQ mittens, pot holders, etc.)
11. Do not alter this grill in any manner
12. Clean and inspect the hose before each use. If there is evidence of abrasion, wear, cuts, or leaks, the hose must be replaced prior to operating the appliance. The replacement hose assembly will be that which is specified by the manufacturer.
13. Move gas hoses as far away as possible from hot surfaces and dripping hot grease.
14. Never keep a filled container in a hot car or car trunk. Heat will cause the gas pressure to increase, which may open the relief valve and allow gas to escape.
15. Keep the grill's valve compartment, burners and circulating air passages clean. Inspect the grill before each use.

WARNING

1. This grill is for outside use only, and should not be used in a building, garage or any other enclosed area.
2. The use of alcohol, prescription or non-prescription drugs may impair the operator's ability to properly assemble or safely operate the grill.
3. Always open grill lid slowly and carefully as heat and steam trapped within the grill can burn you severely.
4. Always place your grill on a hard, level surface far away from combustibles. An asphalt or blacktop surface may not be acceptable for this purpose.
5. Do not leave a lit grill unattended. Keep children and pets away from the grill at all times.
6. Do not place this grill on any type of tabletop surface.
7. Do not use the grill in high winds.
8. Disconnect the propane tank (LP tank) by first turning off valve on top of propane tank, turn off burner valves, then disconnect regulator from valve on propane tank by turning plastic connector counter clockwise. Unscrew wing-bolt in bottom shelf to release the tank for removal.

DANGER

Liquid propane (LP) gas is flammable and hazardous if handled improperly. Know its characteristics before using any propane product.

1. Propane Characteristics; Flammable, explosive under pressure, heavier than air and settles in pools and low areas
2. In its natural state, propane has no odor. For your safety, an odorant has been added.
3. Contact with propane can cause freeze burns to skin.
4. This grill is shipped from the factory for propane gas use only.
5. Never use a propane cylinder with a damaged body, valve, collar or footing.
6. Dented or rusted propane cylinders may be hazardous and should be checked by your propane gas supplier.

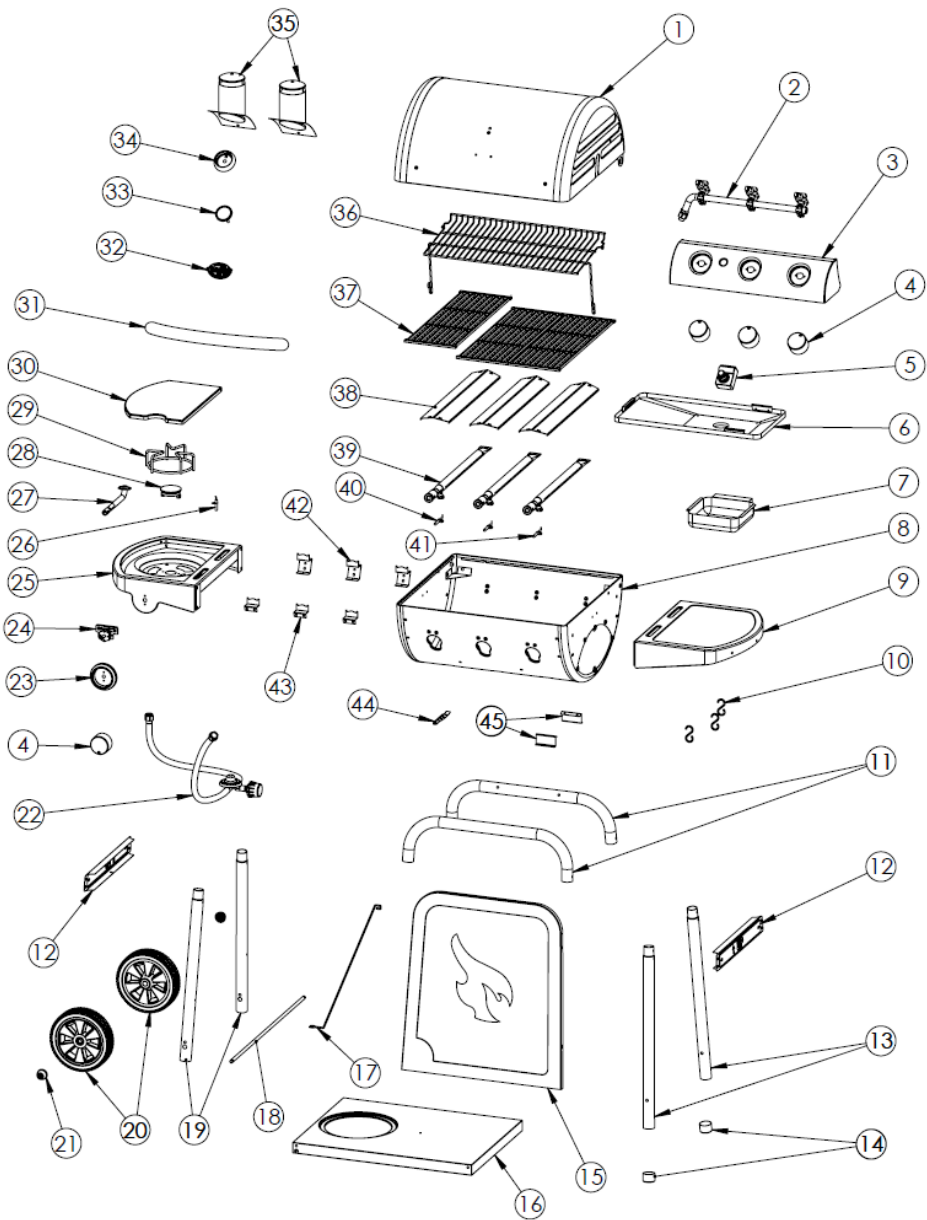

Item #	Description	QTY
1	GAS HOOD ASSEMBLY	1
2	MANIFOLD/VALVES ASEMBLY	1
3	CONTROL PANEL (UFC)	1
4	KNOB	4
5	IGNITOR	1
6	CATCH PAN, SMALL	1
7	GREASE TRAY	1
8	BOTTOM HALF	1
9	SIDE SHELF	1
10	UTENSIL HOOK	3
11	LEG CROSS BAR	2
12	LEG BRACE	2
13	LONG LEG	2
14	LEG CAP	2
15	FRONT PANEL	1
16	BOTTOM SHELF	1
17	TANK BLOCK BAR	1
18	AXLE ROD	1
19	SHORT LEG	2
20	WHEEL	2
21	HUB CAP	2
22	HOSE/VALVE/REGULATOR ASSEMBLY	1
23	KNOB BEZEL	1
24	VALVE, INTEGRATED, SB	1
25	SIDEBURNER SHELF BODY	1
26	SIDE BURNER IGNITOR	1
27	SIDE BURNER PIPE	1
28	CAST IRON BURNER CAP	1
29	POT STAND	1
30	SIDE BURNER LID	1
31	HOOD HANDLE with Wingnuts & Lock Washers	1
32	LOGO PLATE	1
33	THERMOMETER	1
34	BEZEL FOR THERMOMETER (2727)	1
35	GAS SMOKESTACK	2
36	WARMING RACK	1
37	COOKING GRATE	3
38	FLAME SHIELD	3
39	BURNER PIPE	3
40	BURNER SPARKER TIP W/SHORT WIRE	2
41	BURNER SPARKER TIP W/LONG WIRE	1
42	BURNER TUBE/FLARE UP SHIELD SUPPORT (BOLT ON) FOR BACK CG	3
43	BURNER TUBE/FLARE UP SHIELD SUPPORT (BOLT ON) FOR FRONT CG	3
44	CATCH PAN STOPPER BRACKET (IS CURVED)	1
45	CATCH PAN SLIDER BRACKET	2











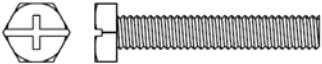
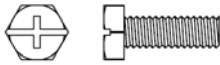

Assembly: Requires 2 people. Get another person to help.

Tools Needed: Pliers, Phillips Head Screwdriver and a 7/16" Nut Driver.

NOTE: Do Not tighten any bolts unless instructed to do so. Tightening too soon may prohibit parts from fitting together. All Hex Nuts should be on the inside of the grill unless stated otherwise. Unpack all contents in a well cleared and padded area.

STOP! Do Not Return to Store. If you are missing parts or need assistance please email us at info@chargriller.com or call 912-638-4724. Do not attempt assembly if you are missing parts.

Hardware: 551053

	1/4-20x 1 1/2" BOLT.....	2 PCS
	1/4-20x 3/4" BOLT.....	2 PCS
	1/4-20x 1/2" BOLT.....	37 PCS
	2/5" FLAT WASHER.....	2 PCS
	1/4" FLAT WASHER.....	5 PCS
	1/4-20 HEX NUT.....	10 PCS
	1/4" LOCK WASHER.....	33 PCS
	HINGE PINS.....	2 PCS
	LARGE HAIR COTTER PIN.....	2 PCS
	SMALL HAIR COTTER PIN.....	2 PCS
	SCREW.....	3 PCS
	#10-24 x 0.40" BOLT.....	6 PCS
	HUB CAP.....	2 PCS
	1/4-20 x 3 1/4" WING BOLT.....	1 PC

Assembly Instructions

Step 1: Insert the Long Legs and Short Legs into the opening ends of the Leg Cross Bars. Then place the Leg Braces over the Legs and Leg Cross Bars and secure them with Lock Washers and two 1/2" Hex Bolts per leg. (**NOTE: The orientation of the Leg Cross Bar is very important for later steps. The two holes on each Leg Cross Bar must be facing toward the center of the assembly.**)

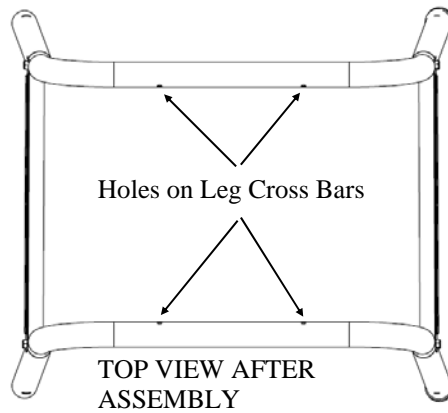
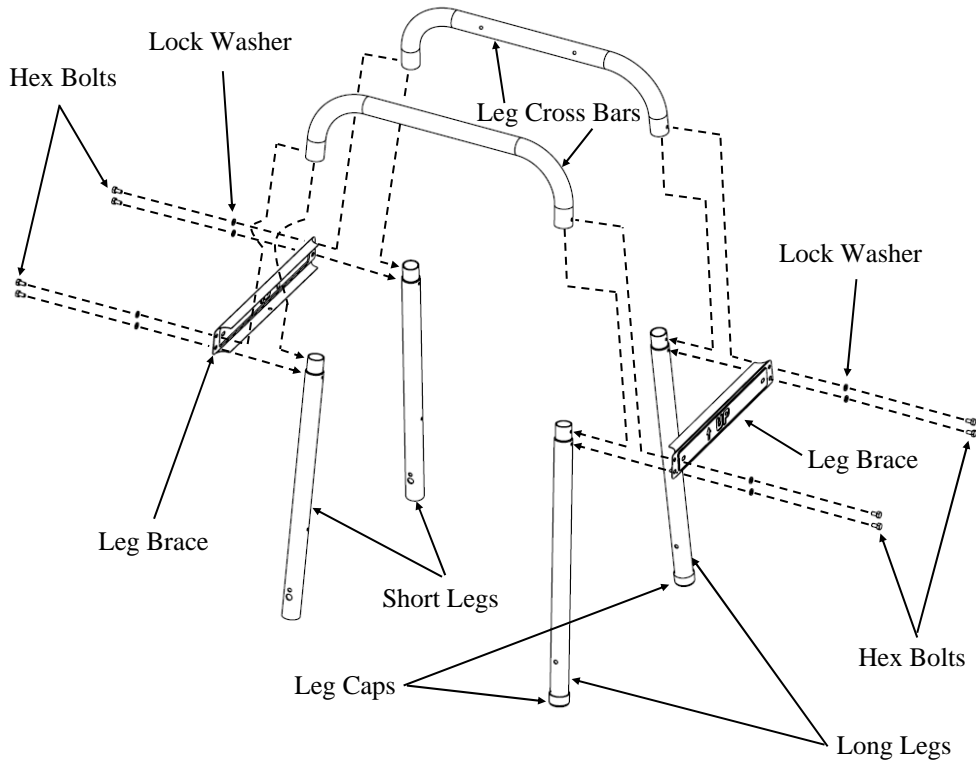

Step 2

Lay the cart assembly from previous step on one side then place the Bottom Shelf between the four legs then secure it with four Lock Washers and four 1/2" Hex Bolts. The Bottom Shelf with the Tank Hole should be on the Short Legs side opposite the Long Legs. **NOTE: Long Legs have Leg Caps on them.**

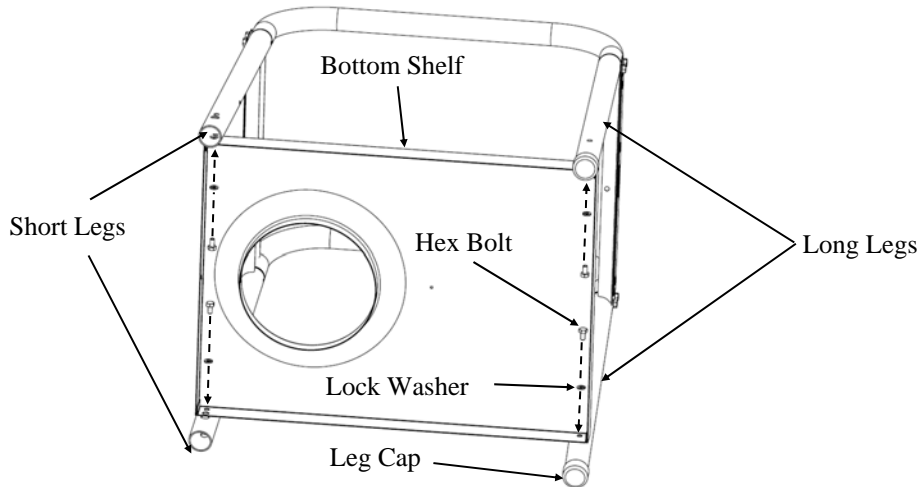

Step 3

Lay the cart assembly down with the Long Legs on the floor then install the Wheels and Wheel Axle. On one end of the Axle insert the Large Cotter Pin into the hole on the Axle and snap in the Hub Cap. Slide one Flat Washer and one Wheel onto the Axle then slide the Axle through the holes on the Short Legs and Bottom Shelf. Complete the assembly by sliding the other Wheel and Flat Washer onto Axle then insert the Large Cotter Pin and snap on the Hub Cap.

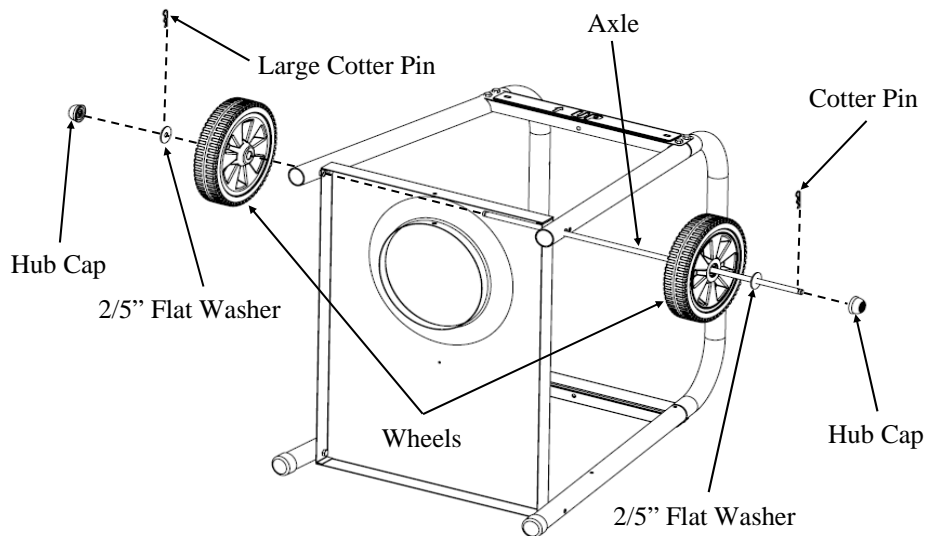

Step 4

Stand the Cart up right. Place Front Panel between Short and Long Legs and secure it with four Lock Washers and four 1/2" Hex Bolts.

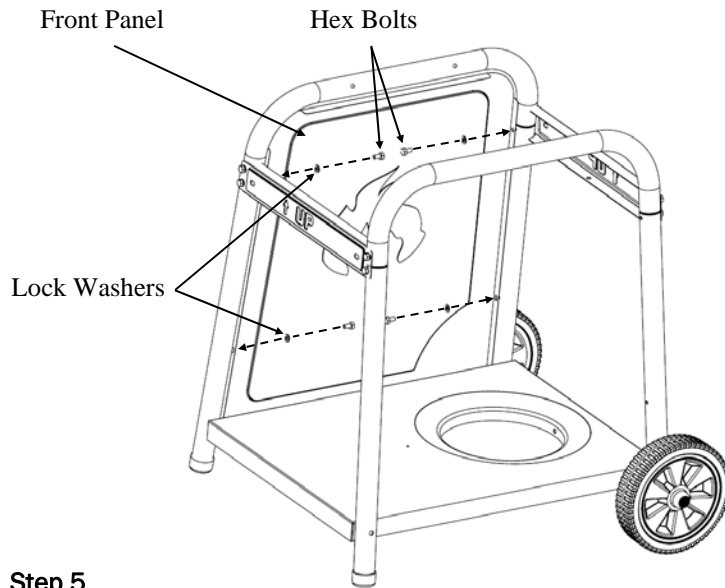

Step 5

Attach two Slider Brackets and one Stopper Bracket onto the bottom of the Grill Body with six #10-24 x 0.40" Bolts. (NOTE: Oriented The Slider and Stopper Brackets as shown below. This is critical for installing the Catch Pan on later step). The Bolts should go in from inside the Grill Body.

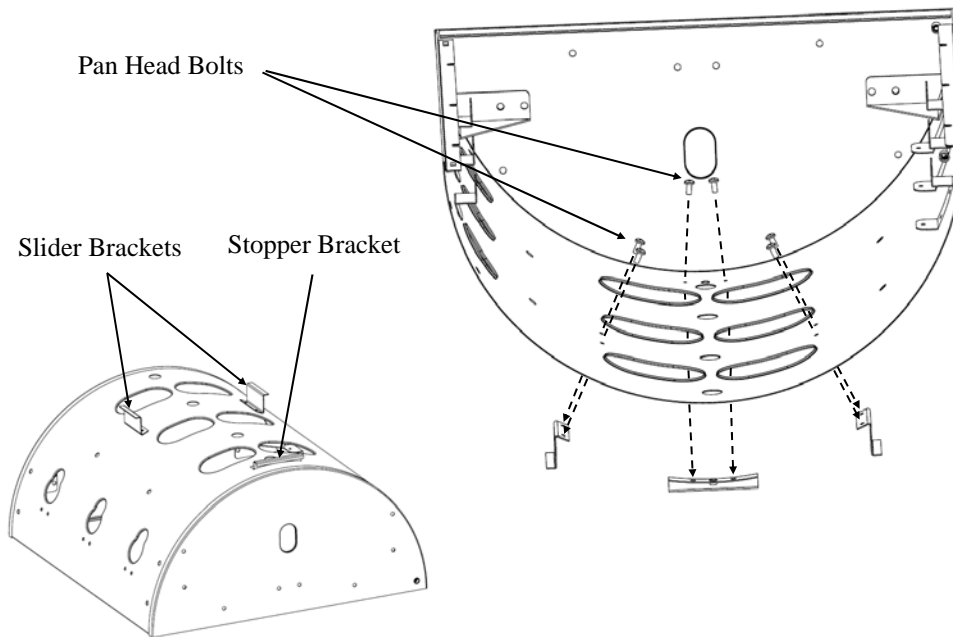

Step 6

Attach the Cylinder Block Bar onto the assembly Cart. First insert the hook on the Cylinder Block Bar into the hole at the center of the Leg Brace then secure the other end with a Flat Washer, Lock Washer, and 1/2" Hex Bolt.

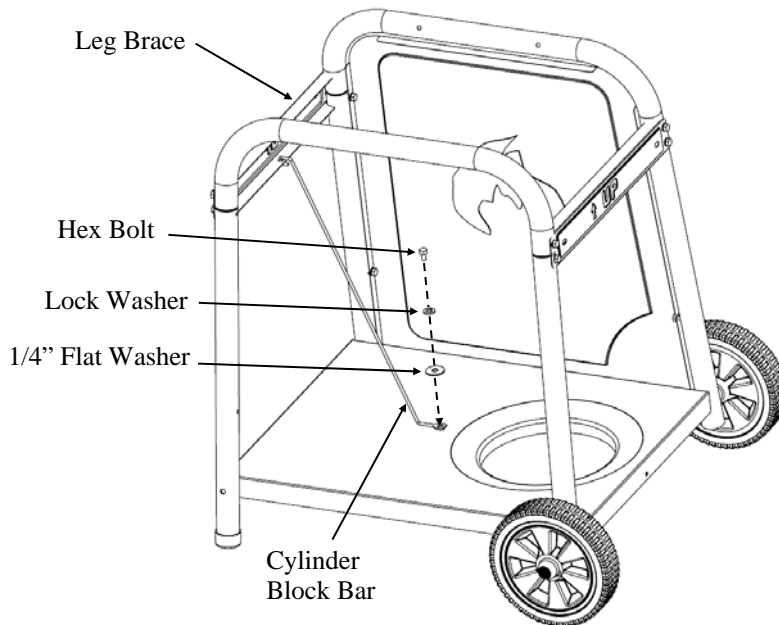

Step 7

Attach the Grill Body to the previous assembly cart using four Lock Washers, four Flat Washers, and four 1/2" Hex Bolts from the inside of the Grill Body. Oriented the Grill body so that the three opening holes on the Grill Body for the burner tubes are facing in the same side as the Front Panel.

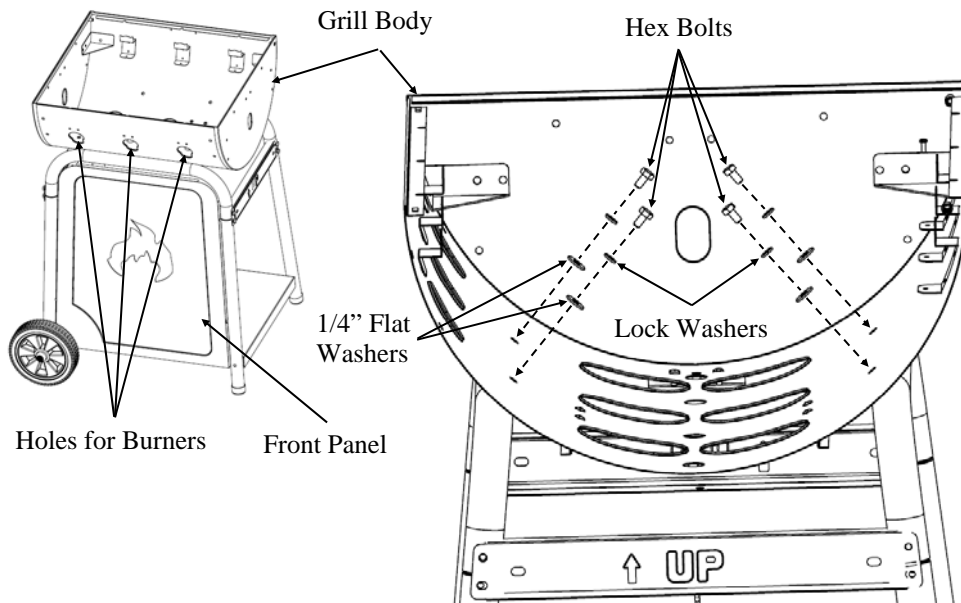

Step 8

Install the Catch Pan onto the bottom of the Grill Body by sliding the Catch Pan underneath the Grill Body bottom. Making sure that the Brackets on the Catch Pan rest on top of Slider Brackets. Slid the Catch Pan all the way till you can hang the Catch Pan side bracket onto the Stopper Bracket.

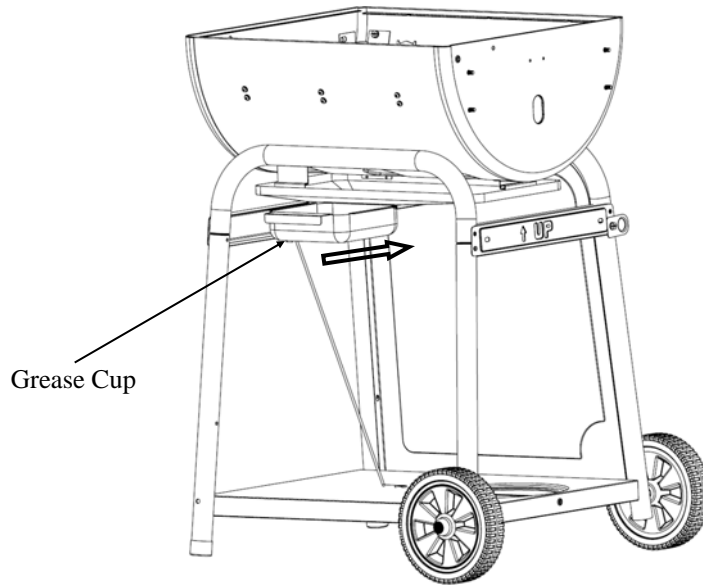
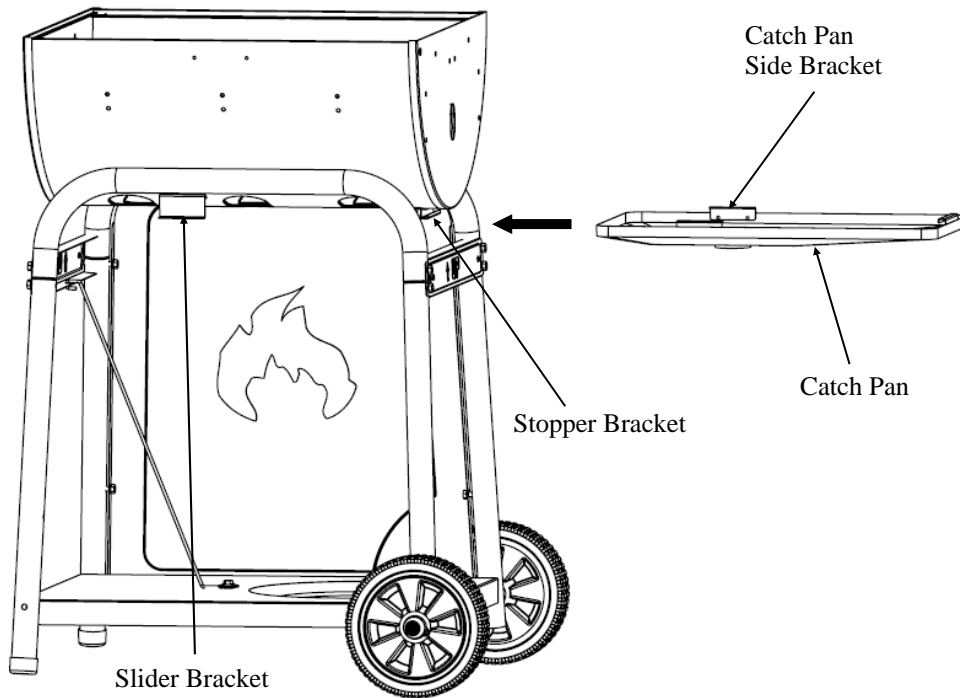

Step 9

Install Knobs onto valve's stems on Side Burner Body/Control Panel Assembly. Then install Side Burner Body/Control Panel Assembly onto the Grill Body. Lay down the Side Burner Body Assembly that connect with the Control Panel on the floor and attach the Control Panel to the front of the Grill Body with four 1/2" Hex Bolts and four Lock Washers (two Hex Bolts and two Lock Washers on each side). Then attach the Side Burner Body Assembly on the side of the Grill Body with four 1/2" Hex Bolts.

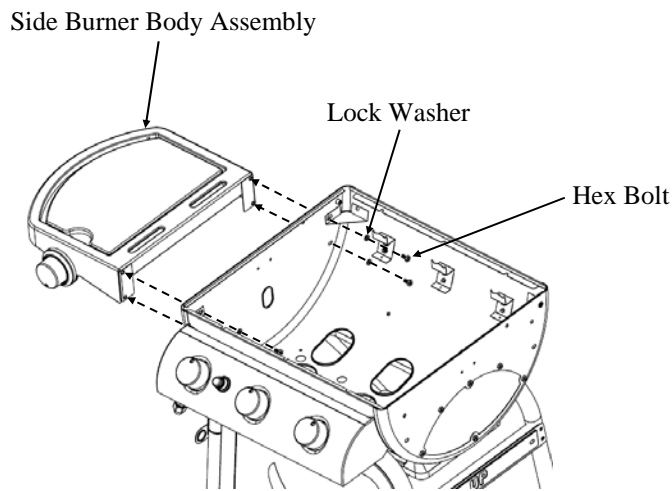
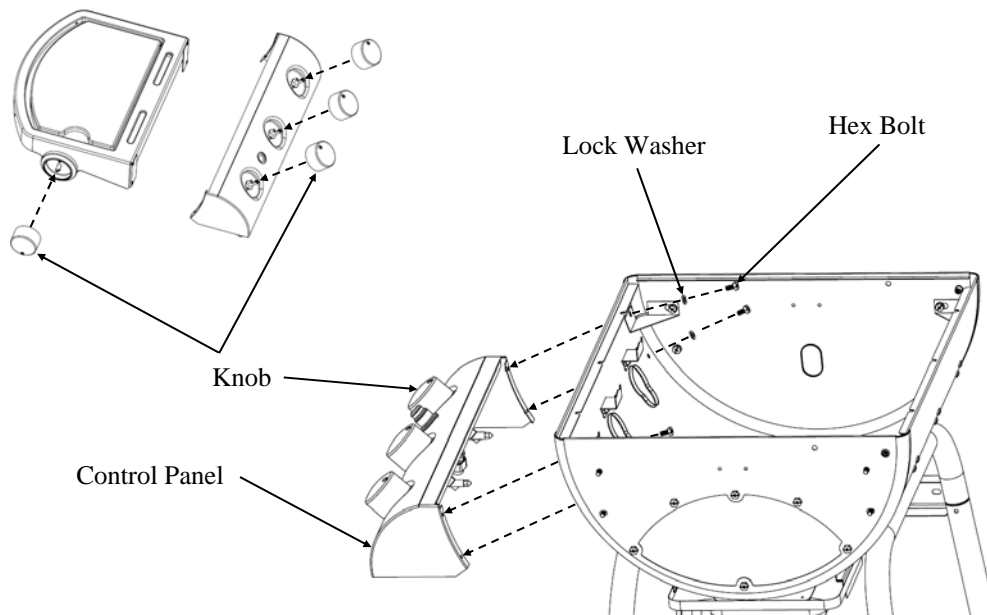

Step 10

Secure the Hose Guide Bracket to the side of the Grill. First unscrew the lower bolt that secure the front side of the leg brace. Then place the Hose Guide over the Leg Brace and re-screw the bolt.

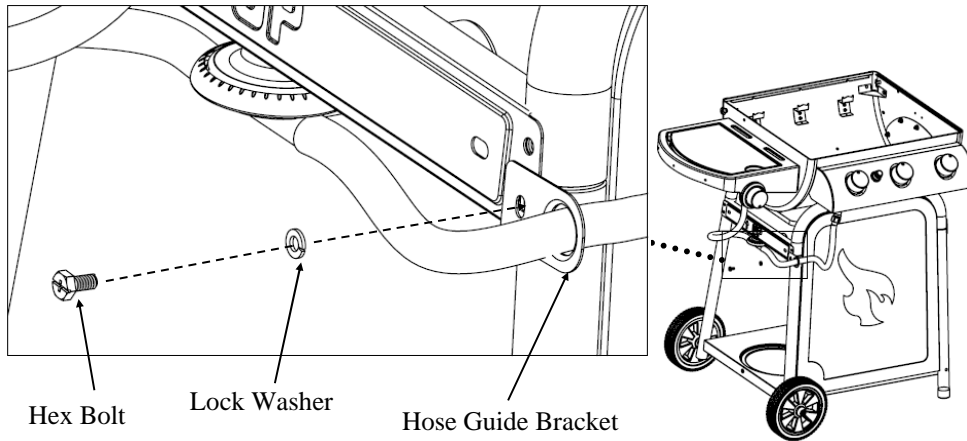

Step 11

Install Side Shelf on the side of the Grill Body using four Lock Washers and four 1/2" Hex Bolts.

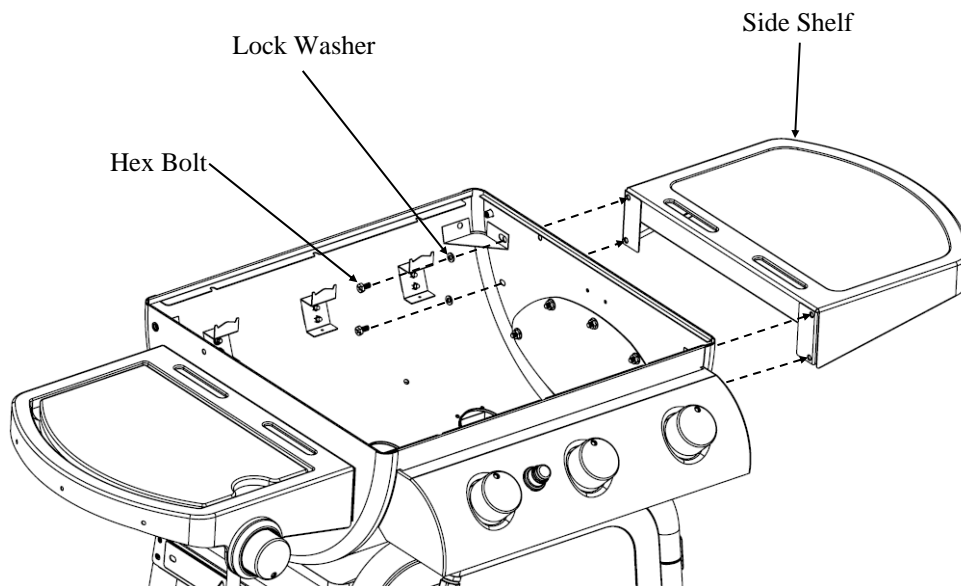

Step 12: Install the Burners into the Grill Body by inserting the IGNITER WIRES and Burners through the open holes at the front of the Grill Body from inside of the Grill Body, see figure 12A. (**NOTE: IGNITER MUST BE ON BOTTOM SIDE OF BURNER**). The BURNER with the longer wire goes on the right side of the GRILL BODY. Making sure that the Valve goes inside each burner, see figure 12B. Then secure the Burners to the Grill Body with the screws provided, see figure 12C.

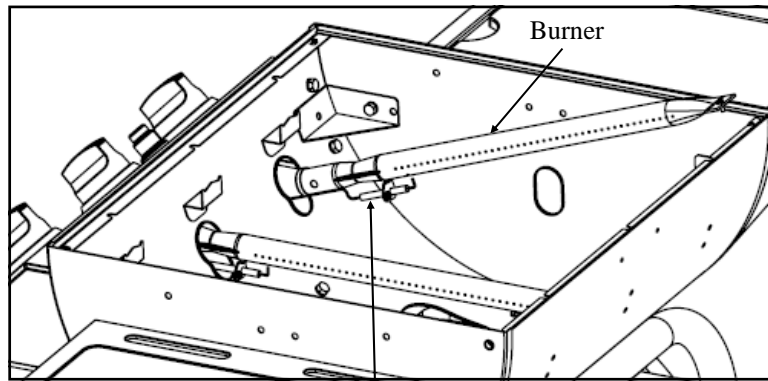

Figure 12A Igniter with Wire

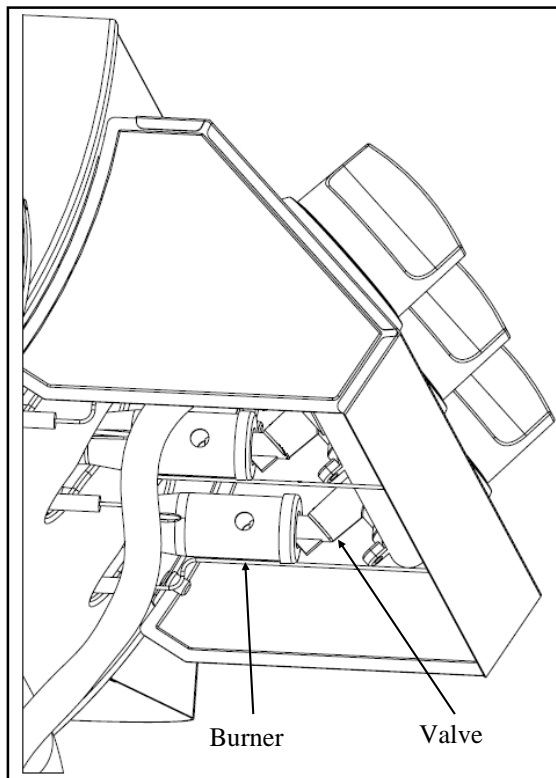

Figure 12B

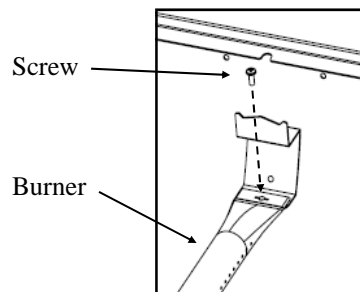
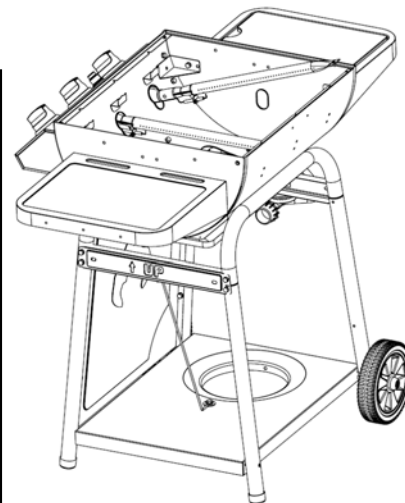
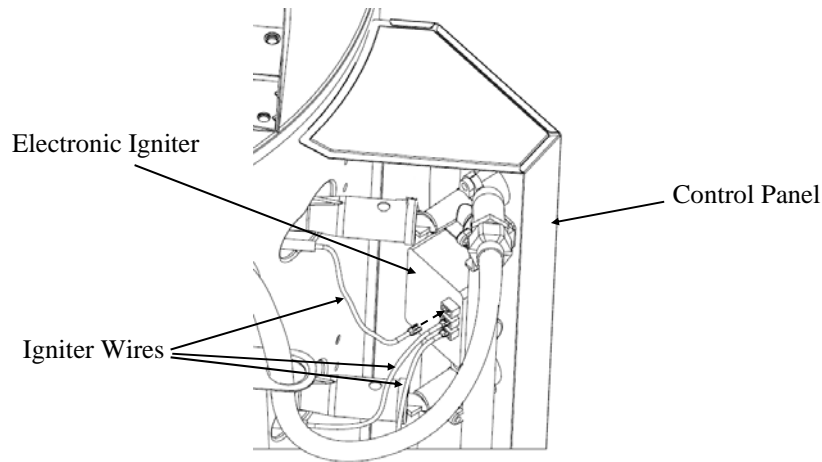

Figure 12C

Step 13

Connect the Igniter Wires to the receptors on the Electronic Igniter underneath the Control Panel. Any Wire can go into any of the three receptors on the Electronic Igniter.



Step 14

Attach the Hood Handle to the Grill Hood with two Lock Washers and two Wing Nuts. Then attach the Thermometer and Bezel to the Grill Hood. The Thermometer goes through the Bezel, the Grill Hood then Flat Washer and secure with a Wing Nuts.

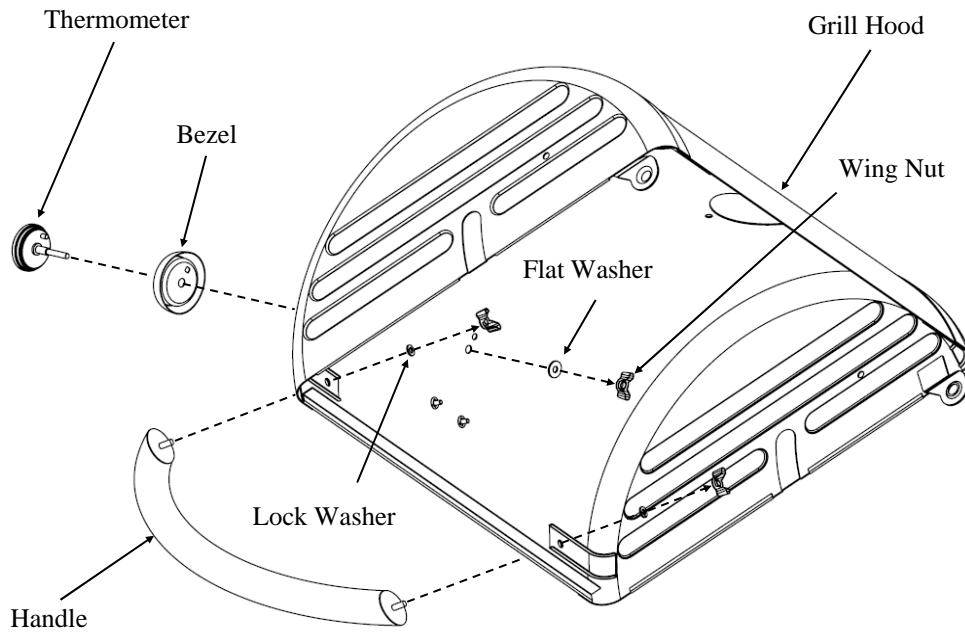

Step 15

Attach the two Smokestacks on the Grill Hood by insert the Chimneys through the holes on the Grill Hood and secure with two 1/2" Hex Bolts and two Hex Nuts for each Chimney.

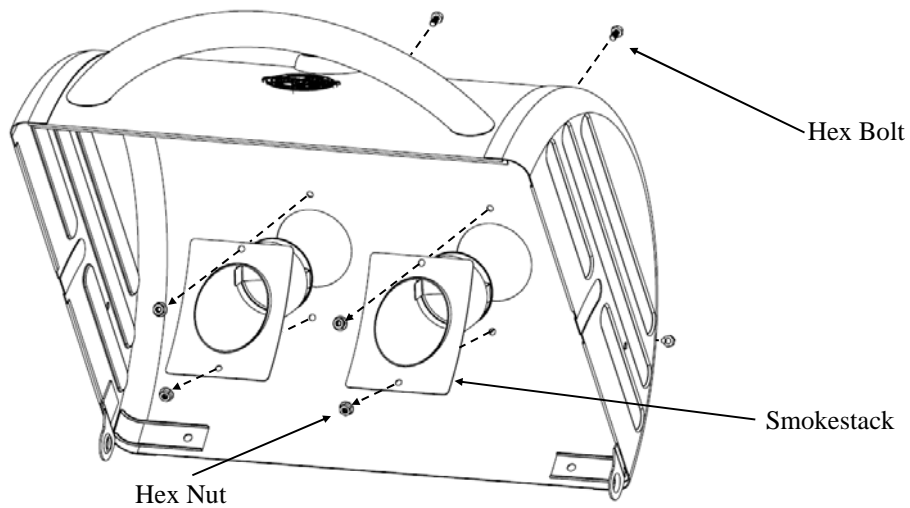

Step 16:

Attach the Grill Hood to the Grill Body using the two Hinge Pins and two Small Cotter Pins provided.

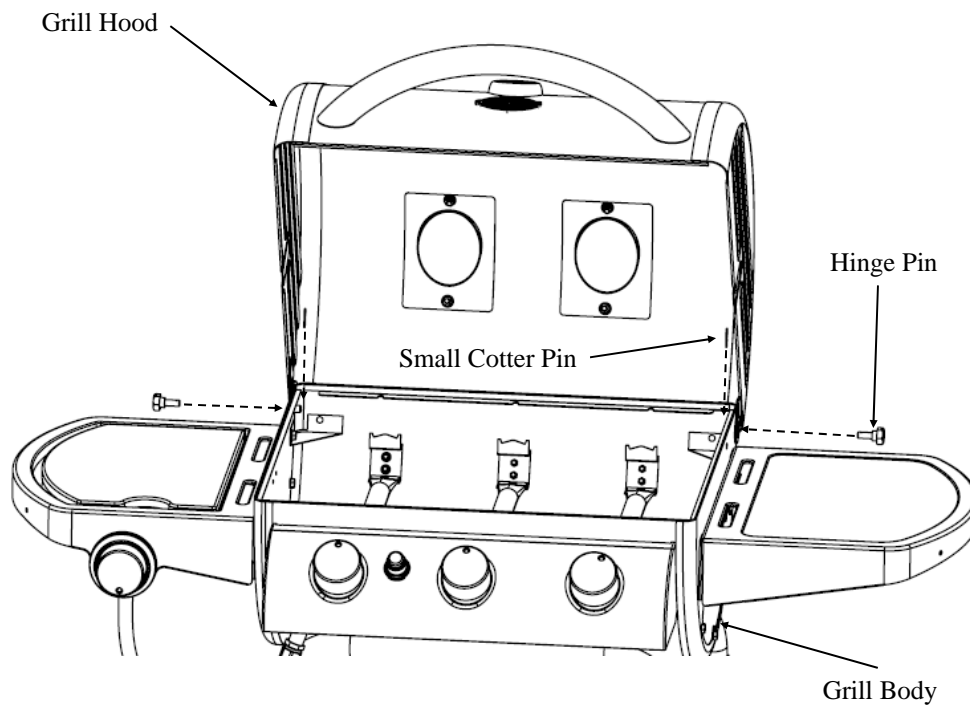

Step 17

To install the Warming Rack first attach two 1 1/2" Hex Bolts on the Grill Hood and two 3/4" Hex Bolts on the Grill Body then secure them with four Hex Nuts. Then Position the Warming Rack onto the Hex Bolts and Secure it with another two more Hex Nuts.

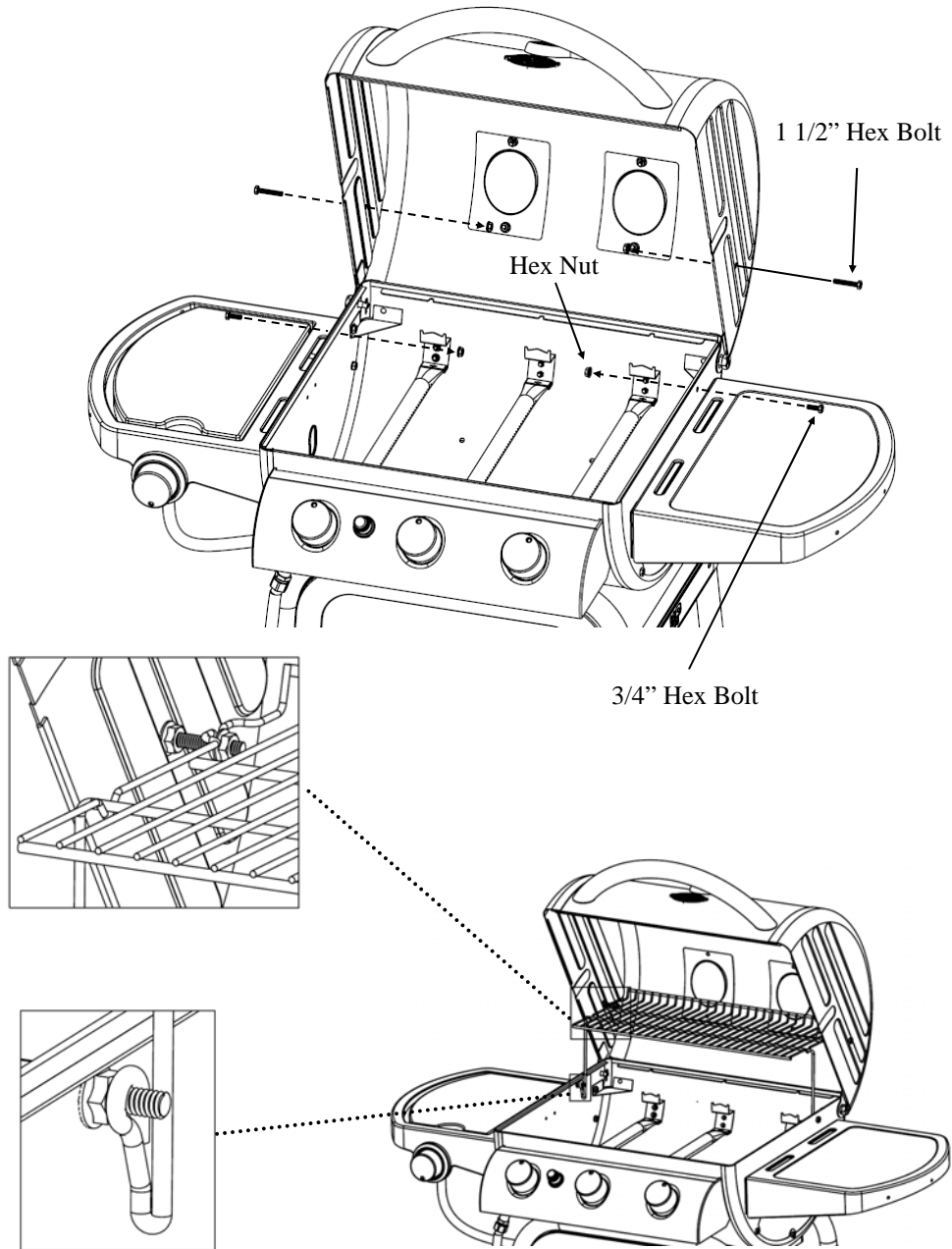

Step 18

Set the Pot Stand in place over the Side Burner. Next place the Flame Shield over the Burners then place the Cooking Grates in place. And insert the Utensils Hooks into the hole on the Side Shelf.

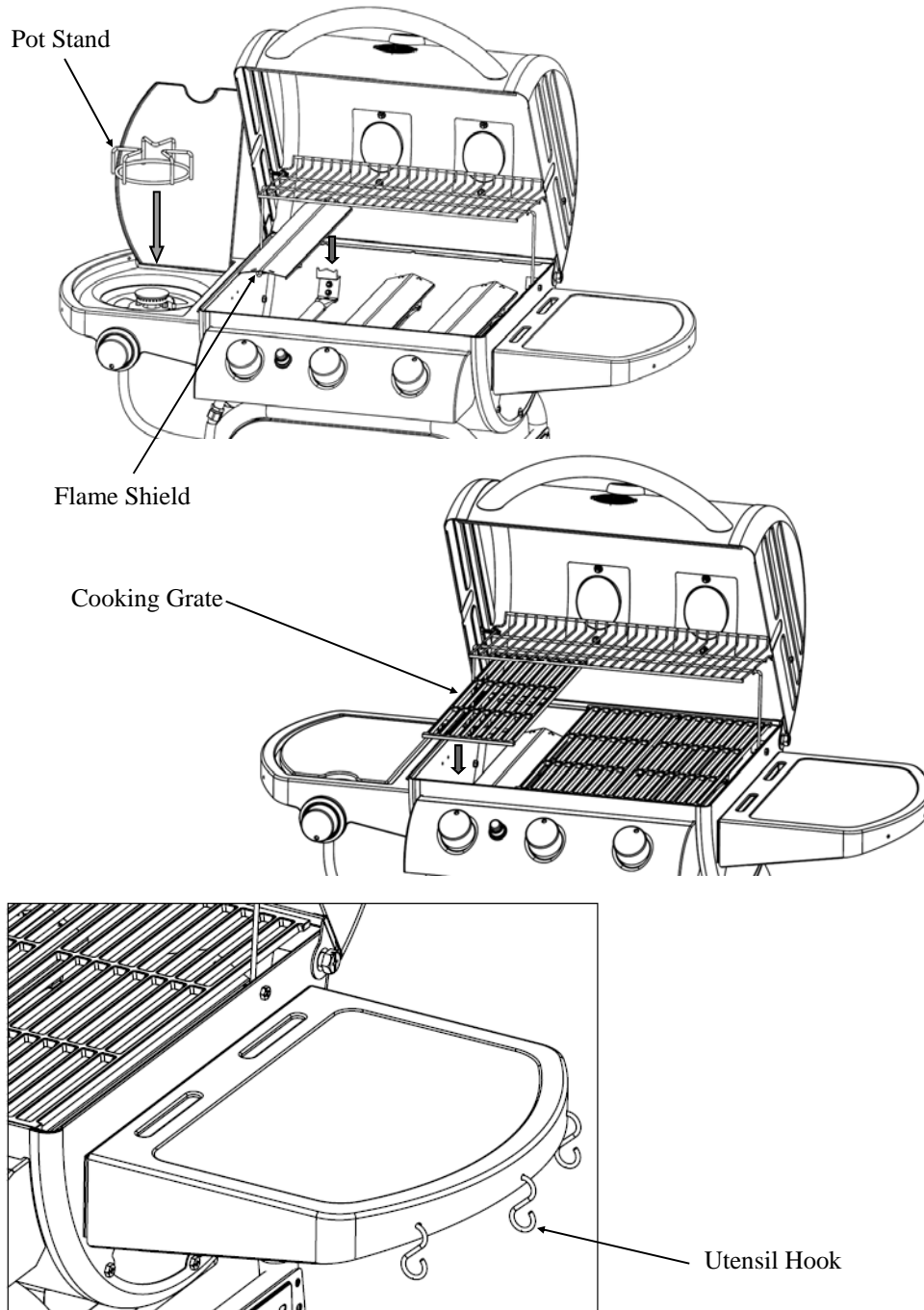

Step 19

Insert and screw in the Wing Bolt into the hole on the side of the Bottom Shelf.

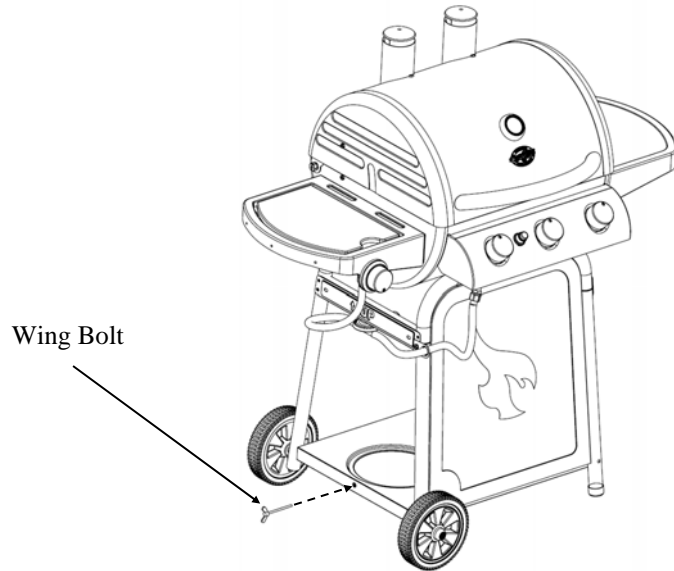

Step 20

Unscrew the Igniter Push Button and insert a “AA” battery into the hole, making sure that the negative side of the battery going in first. Then screw back the Igniter Push Button.

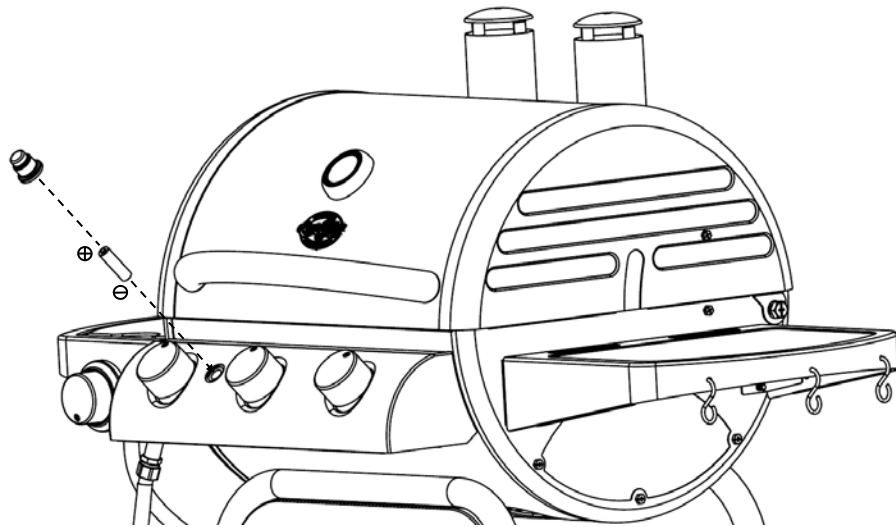

Step 21

Tighten all NUTS and BOLTS.

Fully Assembled



Caution: Use only the regulator provided!

If a replacement is necessary, please call our customer service department, 912-638-4724. Do NOT use replacement parts that are not intended for this grill.

Hint: The paper label that is affixed to the hood is more easily removed when the hood is warm. Any remaining glue residue can be cleaned off with a spray lubricant like WD-40. Do NOT use any other type of solvent or cleaner because this will damage the finish/paint/coating on the grill.

Connecting Gas Cylinder:

The propane gas supply cylinder to be used must be constructed and marked in accordance with the Specifications for propane gas Cylinders of the U.S. Department of Transportation (DOT), or the National Standard of Canada, CAN/CSA B339, Cylinders, Spheres and Tubes for Transportation of Dangerous Goods; and Commission, as applicable. Only cylinders with a listed overfill prevention device (OPD) and marked "propane" may be used. Cylinders with an OPD will have valve handles with three "lobes" (prongs). Only use 20-pound cylinders equipped with a Type 1 cylinder connection device for outdoor cooking appliances. The cylinder must include a collar to protect the cylinder valve. The gas cylinder should not be dropped or handled roughly! If the appliance is not in use, the gas cylinder must be disconnected. Storage of an appliance indoors is permissible **ONLY** if the cylinder is disconnected and removed from the appliance. Cylinders must be stored outdoors out of the reach of children and must not be stored in a building, garage or any other enclosed area. Your cylinder must never be stored where temperatures can reach over 125 F. Before connection, be sure that there is no debris caught in the head of the gas cylinder, head of the regulator valve or in the head of the burner and burner ports. Connect regulator valve and hand-tighten firmly. Disconnect the propane cylinder from the regulator valve when the grill is not in use. **DO NOT** obstruct the flow of combustion air and ventilation air to the grill. The propane cylinder must be arranged for vapor withdrawal and equipped with a listed overfilling prevention device. For proper vapor withdrawal, the cylinder should be used in the proper upright position (refer to illustration under step 22 of page 17).

DANGER:

Never store a spare propane cylinder near this grill.

A fire causing death or serious injury may occur if the above is not followed exactly.



Cleaning and Care

Caution:

All cleaning and maintenance should be done when grill is cool and with the gas supply turned off at the propane cylinder.

DO NOT clean any grill part in a self cleaning oven. The extreme heat will damage the finish.

Cleaning

Burning-off the grill after every use (approx. 15 minutes) will keep excessive food residue from building up. Clean grease tray and cup after EVERY use.

Recommended cleaning materials:

- Mild dishwashing liquid detergent
- Hot water
- Nylon cleaning pad
- Brass wire brush (brush lightly)

DO NOT use cleaners that contain acid, mineral spirits or xylene.

Outside surfaces –

Use a mild dishwashing detergent and hot water solution to clean, then rinse with water.

If the inside surface of the grill lid has the appearance of peeling paint, baked on grease buildup has turned to carbon and is flaking off. Clean thoroughly with strong solution of detergent and hot water.

Rinse with water and allow to completely dry.

Interior of grill bottom – Remove residue using brush, scraper and/or cleaning pad, then wash with dishwashing detergent and hot water solution. Rinse with water and let thoroughly dry.

Cooking Grids – The porcelain grates have a glass-like composition that should be handled with care not to chip. Use mild dishwashing detergent or baking soda and hot water solution. Non abrasive scouring powder can be used on stubborn stains, then rinse with water.

Heat Shield – Clean residue with wire brush and wash with soapy water. Then rinse with water.

Cleaning the Burner Assembly

- Remove grease collector.
- Remove cooking grates and heat shield.
- Remove burner by unscrewing nut from beneath burner “foot” using a screwdriver and pliers.
- Lift burner up and away from gas valve orifice.
- Clean inlet (venturi) of burner with small bottle brush or compressed air.
- Remove all food residue and dirt on outside of burner surface.
- Clean any clogged ports with a stiff wire (such as an opened paper clip)
- Inspect burner for any damage (cracks or holes). If damage is found, replace with new burner. Reinstall burner; check to insure that gas valve orifices are correctly positioned inside burner inlet (venturi). Also check position of spark electrode.

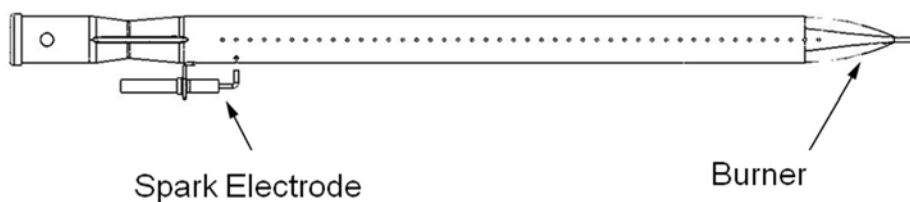



Stand in front of the grill to operate the controls.

Note: Before starting the grill, check for leaks. Make sure the regulator valve is securely fastened to the burner and the cylinder.

To prevent fire or explosion hazard when testing for a leak:

1. Always perform the “leak test” as described below before lighting the grill or each time the cylinder is connected for use.
2. Do not smoke or allow other sources of ignition in the area while conducting a leak test.
3. Conduct leak test outdoors in a well-ventilated area.
4. Do not use matches, lighters or a flame to check for leaks.
5. Do not use grill until any and all leaks are corrected. If you are unable to stop a leak, disconnect the propane supply. Call a gas appliance serviceman or your local propane gas supplier.

To Perform a Leak Test:

Make a 2-3 oz (0-90ml.) of leak solution by mixing one part liquid dishwashing soap with three parts water in a spray bottle.

Note: Make sure control knobs are off.

Spray solution on the tank valve to regulator connection, the “Y” joint in the hose, the connection to the manifold behind the main control panel, and the connection to the side burner valve.

Inspect the solution at the connection looking for bubbles. If NO bubbles appear, the connection is secure. If bubbles appear, you have a leak. Check the regulator connection as follows: Disconnect regulator from the tank and reconnect, making sure the connection is secure. Retest with solution. If you continue to see bubbles, replace the cylinder.

Lighting Your Grill

Danger: Failure to open hood while igniting the grill or not waiting 5 minutes to allow the gas to clear if the grill does not light, may result in an explosive flare-up which can cause serious bodily injury or death.

Before cooking on this grill for the first time, operate the grill for about 15 minutes with the lid closed and the gas turned on “high”. This will “heat clean” the internal parts and dissipate odor from the manufacturing processes and painted finish.

Main Burners:

1. Always open the lid before lighting the grill.

Attempting to light the burner with the lid closed may cause an explosion!

2. Make sure there are no obstructions of airflow to the gas unit. Spiders and insects can nest within and clog the burner/venturi tube at the orifice. A clogged burner tube can lead to a fire beneath the appliance.
3. Make sure all burner knobs are in the OFF position.
4. Open the valve on the LP gas cylinder.
5. Ignite only the burners you desire to use, using the same method for each burner: Push in and rotate knob to “HIGH” then push and hold Electronic Ignition button until the burner lights. **If the burner does not light in 5 seconds**, return the knob to **OFF**, wait **5 minutes** for the gas to clear and repeat the procedure. After the burner ignites, repeat the same procedure with any other burner desired. Adjust knob(s) to desired cooking setting.

After lighting, observe the burner flame, make sure all burner ports are lit.

If burner flame goes out during operation, immediately turn the gas “off” at the control panel and at the gas cylinder and open hood/lid to let the gas clear for about 5 minutes before re-lighting. **Clean your grill after each use**, DO NOT use abrasive or flammable cleaners, as it will damage the parts of this product and may start a fire.



Side Burner

1. Open lid during lighting. Lid must be open when burner is on.
2. Burner valves must be in the "off" position.
3. Open cylinder valve.
4. Push in side burner valve knob fully and rotate slowly about ¼ turn counter-clockwise until a click is heard. **If the burner does not light**, immediately turn the valve knob to OFF. **Wait 5 minutes** for the gas to clear and repeat the procedure.

After burner ignites, adjust valve knob to desired cooking setting.

Shutting Off Burners:

1. Always turn the valve knob(s) clockwise to the HI position, then push in and turn to OFF. Never force the knob without depressing it as this can damage the valve. For Side Burner, push in and turn to OFF from any location that it is at.
2. Promptly turn the gas supply OFF at the propane cylinder.
3. Close the lid of the grill.

Observe Flame Height When Lit:

Flame should be a Blue / Yellow color.

To visually check that the burner is operating, look at the burner flame through the flame viewing hole. The flame should be approximately 1/2-3/4 inch long with the high setting.

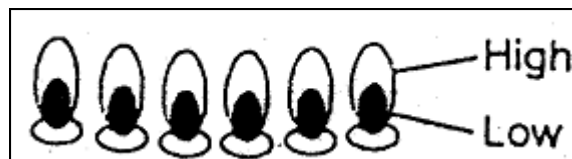

Lighting Burner With a Match:

1. Place a match in the end of the match holder that is installed on the side of Grill Housing. Once lit, immediately place the flame through the cooking grates as shown near the burner ports.
2. Press in knob and rotate counter-clockwise to the High setting and burner should light immediately.
3. Adjust burners to desired cooking settings

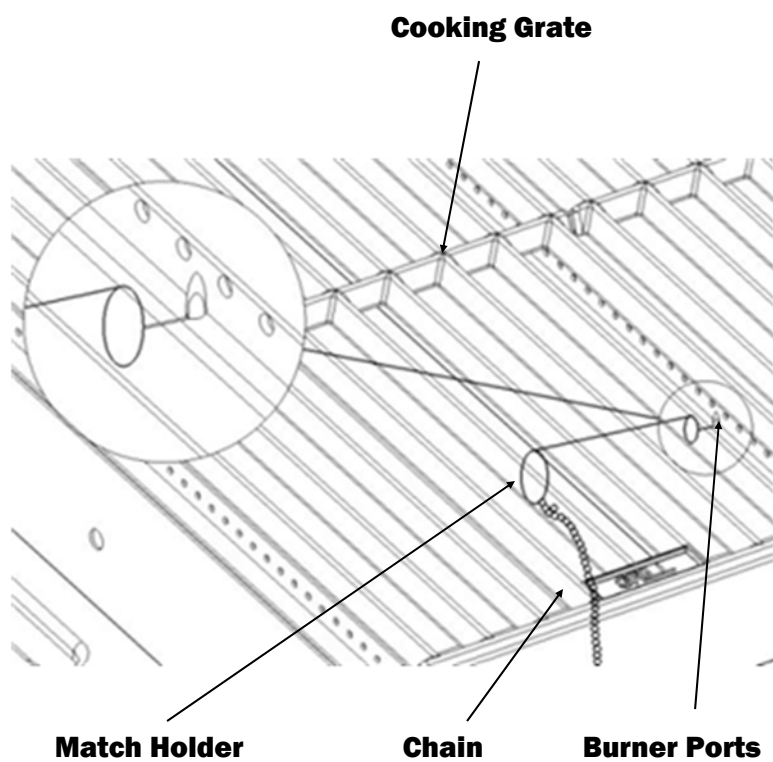

Gas Grill Trouble Shooting

Problem	Possible Cause	Prevention/Cure
Burner will not light using knobs	Wires/or electrode covered with cooking residue.	Clean wire and/or electrode, with rubbing alcohol
	Electrode and burners are wet.	Wipe dry with cloth
	Electrode cracked or broken -sparks at crack	Replace electrode
	Wire loose or disconnected	Reconnect wire or replace electrode/wire assembly.
Burner will not light with match.	No gas flow.	Check if propane tank is empty. If propane tank is not empty. Refer to "Sudden drop in gas flow or reduced flame height". If empty, replace or refill.
	Coupling nut and regulator not connected.	Turn the coupling nut about one-half full connected to three quarters additional turn until solid stop. Tighten by hand only -do not use tools.
	Obstruction of gas Flow.	Clear burner tubes. Check for bent or kinked hose.
	Disengagement of burner to valve.	Re-engage burner and valve.
	Insect nests in venturi (burner insert).	Clean venturi.
	Burner ports clogged or blocked.	Clean burner ports.
Sudden drop in gas flow or reduced flame height.	Out of gas	Change Propane Tank
	Excess flow safety device may have been activated.	Turn off knobs, wait 30 seconds and light grill. If flames are still too low. Reset the excessive flow safety device by turning off knobs and propane tank valve. Disconnect regulator. Turn burner control knobs off. Reconnect regulator and leak check connections. Turn propane tank valve on slowly, wait 30 seconds and then light the grill.
Irregular flame pattern, flame does not run the full length of burner.	Burner ports are clogged or blocked.	Clean Burner ports

Gas Grill Troubleshooting, continued

Problem	Possible Cause	Prevention/Cure
Flame is yellow or orange.	New burner may have residual Manufacturing oils.	Burn Grill for 15 minutes with the lid closed.
	Insect nests in venturi.	Clean venturi.
	Food residue, grease or seasoning salt on burner.	Clean burner.
	Poor alignment of valve to burner venturi.	Assure burner venturi is properly engaged with valve.
Flame blows out	High or gusting winds	Turn front of grill to face wind or increase flame height. (We recommend not using grill during high winds)
	Low gas pressure	Change Propane Tank
	Excess flow valve tripped	Refer to "Sudden drop in gas flow or reduced flame height"
Flare-Up	Grease buildup	Clean Grill
	Excessive fat in meat	Trim fat before grilling
	Excessive cooking Temperature	Adjust (lower) temperature accordingly
Persistent grease fire	Grease trapped by food buildup around burner system.	Turn knobs to OFF. Turn gas off.
Flashback (fire in burner tube(s))	Burner and/or burner tubes dirty.	Clean burner and/or burner tubes.
Inside of lid appears to be peeling - like paint peeling	Baked on grease buildup has turned to carbon and is flaking off.	Clean inside of lid thoroughly. The lid is not painted on the inside

GRILL PREPARATION & OPERATING INSTRUCTIONS

PLEASE NOTE: NO RETURNS ON USED GRILLS

Read all safety warnings and instructions carefully before assembling and operating your grill.

1. Note: The interior of the grills are not painted, they are coated with vegetable oil. **DO NOT** remove this coating. Cure grills prior to cooking to protect the interior and exterior finishes and prevent adding unnatural flavors to your food. (A) Lightly coat **ALL INTERIOR SURFACES** (including **INSIDE OF BARREL, AND COOKING GRATES**) with additional vegetable oil (spray vegetable oil is easiest but **KEEP AWAY FROM HOT COALS, FIRE OR FLAME**). Light burners and set on Medium-Low heat. (D) Gas Grills: Close lid and maintain heat at approximately 250° F (120° C) for two hours. You can lightly coat the exterior the GRILL body (while warm) with vegetable oil and wipe off excess with a rag. This will extend the life of the finish, much like waxing a car. Your GRILL will then be ready for use. Note: Oil will drip from the GRILL for several uses, but will slow over time.

NEVER EXCEED 450° F (230° C) BECAUSE THIS WILL DAMAGE THE FINISH AND CONTRIBUTE TO RUST. PAINT IS NOT WARRANTED AND WILL REQUIRE TOUCH-UP. THIS UNIT IS NOT WARRANTED AGAINST RUST.

2. This grill is made of steel and cast iron, which **WILL RUST, ESPECIALLY IF NOT PROPERLY CARED FOR.**

3. You may fill unwanted holes with Nuts & Bolts (Not Provided).

NOTE: Smoke will escape from areas other than the smokestacks. This will not affect your cooking .

GRILLING RECIPES

DIRECT METHOD

STEAK (& ALL MEATS): Cook food directly above coals/heat. Generally speaking, to grill meats, raise fire grate to high position (hot) and sear for one minute on each side with the lid open to seal in flavor and juices. Then lower fire grate to medium position with lid closed and cook to desired doneness.

Control heat with dual dampers and adjustable fire grate.

BETTER BARBECUE: Place grilled meat back in the marinade for several minutes before serving – it will become tastier and juicier. **CAUTION:** Boil extra marinade first to kill bacteria remaining from the raw meat.

Tip: Cooking with a MEAT THERMOMETER ensures food is fully cooked. Insert into thickest part not touching bone & allow five minutes to register. Internal temperatures for BIRDS should be 170F to 180F and meat should be 140F for rare, 160F medium and 170F for well done.

MARINATED FLANK STEAK: Mix marinade ingredients in nonmetal dish. Let steak stand in marinade for no less than 4 hours in refrigerator. Brown each side for 5 minutes, but center should remain rare. Cut steak diagonally across the grain into thin slices before serving. Grill with fire grate in high (hot) position with lid open or closed.

MARINADE: 1/2 cup vegetable or olive oil, 1/3 cup soy sauce, 1/4 cup red wine vinegar, 2 tbs. Lemon juice, 1 tsp. Dry mustard, 1 minced clove garlic, 1 small minced onion, 1/4 tsp pepper.

QUAIL OR DOVES: Cover birds in Italian dressing (Good Seasons or Kraft Zesty), marinate overnight, pour off dressing and cover with Texas Pete Hot Sauce for 6 hours. Wrap birds in thick bacon secured by a toothpick. *Place on grill – keep turning until bacon is black. Grill for 20 minutes. Sear with lid open and fire grate in high (hot) position for 1 min each side before lowering grate and closing lid. *OR SMOKE by placing birds in center of GRID with fire in both ends of FIRE BOX.

KABOBS: Alternating on skewers any combination of meat, onions, tomatoes, green peppers, mushrooms, zucchini, circular slice of corn-on-the-cob, or pineapple. Meat could consist of chunks of shrimp, scallops, lobster, chicken, sausage, pork, beef, etc. Marinate the meat in refrigerator for several hours. Grill each side approximately 7 minutes turning occasionally while basting with marinade. Leave a small amount of room between pieces in order to cook faster. Grill with lid up and the fire grate in the lowest position. See marinade recipe on last page.

KABOB MARINADE: Mix 1 cup soy sauce, 1/2 cup brown sugar, 1/2 cup vinegar, 1/2 cup pineapple juice, 2 teaspoons salt, 1/2 teaspoon garlic powder and bring to a boil. Marinate beef in mixture a minimum of 4 hours.

HOT DOGS: Grill with lid up and fire grate in high (hot) position for approximately 6 minutes, turn every few minutes.

HAMBURGERS: Mix in chopped onions, green peppers, salt, sear 3/4 inch patties on each side with fire grate in high position for a few minutes. Lower fire grate to medium position and grill with lid down to avoid flare-ups. Cook each side 3 to 7 minutes according to desired doneness. Cook ground meat to 150 internally or until juice runs clear (free of blood) for prevention of E-coli.

Burgers can be basted with marinade when turning and/or other ingredients can be mixed in with the ground beef such as chili sauce or powder; or you may marinate by allowing to stand in marinade for 1 or 2 hours at room temperature before cooking; or let stand in covered dish in refrigerator up to 24 hours. Bring to room temperature before cooking.

See meat marinade on page 9.

SHRIMP (Peeled) & Crayfish: Place on skewers, coat with melted butter and garlic salt. Grill 4 minutes on each side or until pink. Cocktail sauce optional.

BAKED POTATOES: Rub with butter and wrap in foil and cook on grill with lid down for 50 minutes. Turn after 25 minutes (no need to turn if smoked). Squeeze to check for doneness.

SWEET CORN IN HUSKS: Trim excess silk from end and soak in cold salted water 1 hour before grilling. Grill 25 minutes – turning several times.

3-Burner Grill 3072

ACCESSORIES ORDER FORM



TO ORDER

Visit:

www.CharGriller.com

or

CALL: 912-638-4724

or

FAX: 912-638-2580

or MAIL:

P.O. Box 30864

Sea Island, GA

31561



FedEx



Visit our online store at:
www.chargriller.com
for more Char-Griller®
Professional Accessories™

Char-Griller® Professional Accessories



Cover #3087

- Custom Fit, Weather Resistant
- Protects grill finish
- Cover Accommodates Side Shelf or Side Fire Box



Rotisserie #5022

- Excellent for effortless grilling
- Universal Fit for Any Grill



Side Fire Box #22424

- For Charcoal grilling
- Attaches to grill in minutes

Apron #8805

- Machine Washable
- Two Front Pockets
- Adjustable Straps



ACCESSORIES ORDER FORM



TO ORDER
 Visit our online store at:
www.CharGriller.com
 or
CALL: 912-638-4724
 or
FAX: 912-638-2580
 or **MAIL:**
P.O. Box 30864
Sea Island, GA 31561

Tank Cover #9955

- Weather Resistant Nylon
- Fits standard 20lb LP tank
- Velcro Close
- Elastic at Top and Bottom
- Cover Only Tank Not Included



Raw Cast Iron Grate

- Even Heat, Great For Searing
- Non Stick, Non Warp

Name _____ Telephone _____
 Street Address _____
 City / State / Zip _____
 Email _____

Check or Money Order (Sorry—No C.O.D.s)
 Check orders will be held 2 weeks before shipment

Please bill my credit

card:
 EXPIRATION DATE

Prices & policies subject to change
 15% Restocking Fee on all returns
 No Returns on Used Product.
 Please Call For updated Pricing
 and Product Availability.

Georgia Customers add a 7% sales tax.
 Washington state Customers add a 10% sales tax

For current pricing, visit www.CharGriller.com or call 912-638-4724

Qty.	Product	Price	Qty.	Product
	Tank Cover			Rotisserie
	Adjustable Fit Apron			Side Fire Box #22424
	Cover For Grill #3087			Raw Cast Iron Grate
				Shipping Charge
ORDER NOW!				Total

Page intentionally left blank for notes



**P.O. Box 30864
Sea Island, GA
31561
912-638-4724
www.CharGriller.com**



Warranty Information - Gas Grill

Char-Griller® will repair or replace any defective part of its grillers/smokers for a period of up to one year from the date of purchase. Char-Griller® will also repair or replace the body (lid and bottom half) of its grillers/smokers if the metal is rusted through or burned through for a period up to five years. Char-Griller will repair or replace any defective part of its side fire boxes for a period up to one year from the date of purchase. Char-Griller® gas grill burners have a five year warranty from the date of purchase.

Proof of purchase, proof of purchase date and prepaid return of the item in question may be required. Misuse, abuse, or commercial use nullifies all warranties. Paint/finish is not warranted. Products are not warranted against rust.

The warranty is for replacement of defective parts only. Manufacture will not be responsible for damage resulting from accident, alteration, misuse, abuse, hostile environments, improper installation, installation not in accordance with local codes of service of unit.

This limited warranty does not cover any scratches, dents, corrosion or discoloring by heat, abrasive and chemical cleaners nor any components used in the installation of the appliance.

Save your receipt for all warranty claims.

