

Rubbermaid®

FastTrack®

L8-5M12-P0





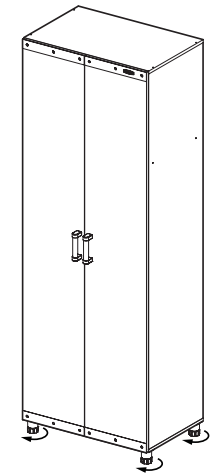



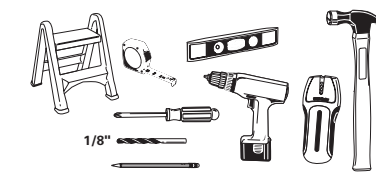

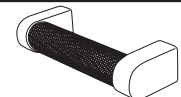

Rubbermaid Incorporated,
Huntersville, NC USA 28078-1801
U.S.A. 1-888-895-2110
Canada 1-866-595-0525
www.rubbermaid.com

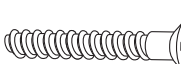
A *Newell Rubbermaid* Company

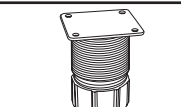

5M12 – Tall Cabinet Assembly Steps

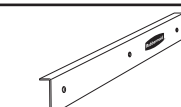
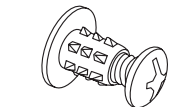

Pieces	Qty	Pieces	Qty
Right Vertical Panel (3814630)	1	Handles with Screws, #8 x 1-1/4", Phillips (NP5M2100)	 2
Left Vertical Panel (3814523)	1		 4
Top and Bottom Panels (3814705)	2	Hinge Plate Screws, #6 x 5/8" Phil, Flat Head (1602160)	 12
Doors (3814680)	2	Pan Head Screw, #8 x 1/2", Phillips (1604281)	 1
Adjustable Shelves (3814698)	2	Confirmat Screws, 5mm x 40mm (1602376)	 12
Fixed Shelf (3814672)	1	Euro Screws (1602392)	 12
Hinge Plates (1608770)	6	Backer Board (2901892)	 1
Hinges (NP5M2200)	6	Nails (1608217)	 40
Shelf Support Pins (FG3F80H1CHROM)	8	Feet with Screws, #8 x 5/8", Phillips, Flat Head (NP5M2300)	 4
Plastic Screw Covers (1812256)	4		 12
Wall Mount Screw, #10 x 2", Phillips, Flat Head (1603168)	1	Metal Plates (NP5M2400)	 4
Wall Spacer (1804899)	1	Metal Plate Fasteners with Screws (NP5M2500)	 12
Wall Attachment Bracket (8403488)	1	Door Pads (1811399)	 4

STEP 1**Parts Required**

- Left Vertical Panel (1)
- Right Vertical Panel (1)
- Hinge Plates (6)
- Euro Screws (12)

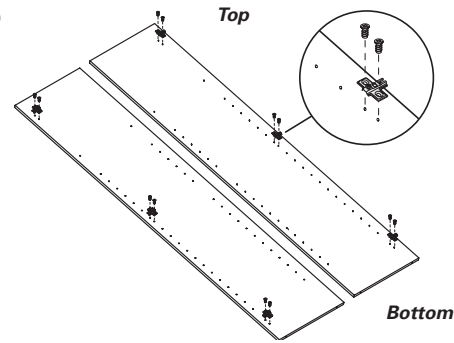
**STEP 3****Parts Required**

- Bottom Panel (1)
- Confirmat Screws (4)
- Feet (4)
- Foot Screws (12)

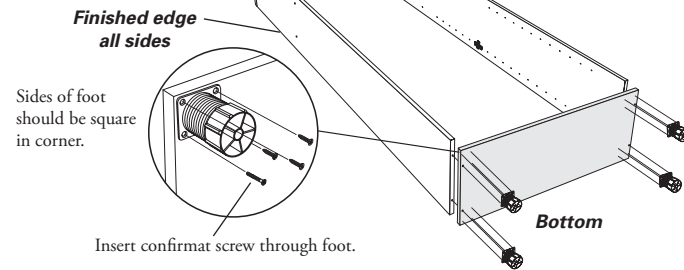
**STEP 5****Parts Required**

- Backer board (1)
- Nails (40)

Attach the backer board to the base with the black side facing into the cabinet using the nails provided.

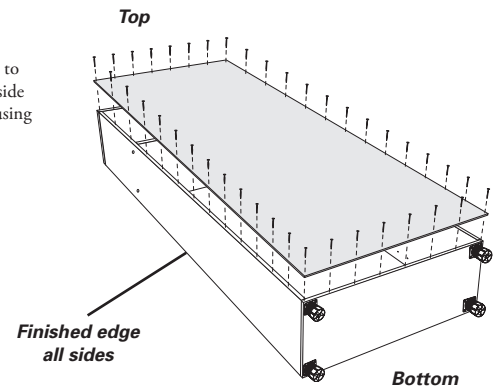
**STEP 7****Parts Required**

- Adjustable Shelves (2)

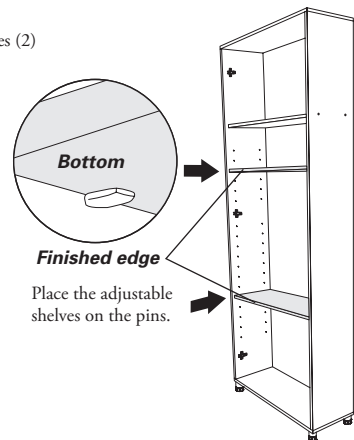
**STEP 2****Parts Required**

- Top Panel (1)
- Confirmat Screws (4)

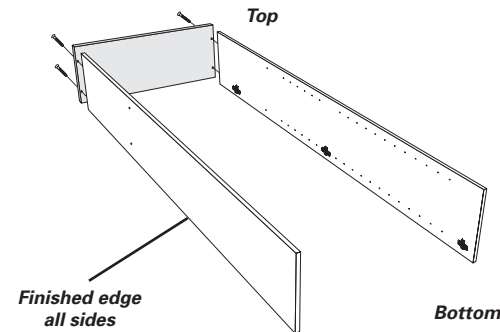
**STEP 4****Parts Required**

- Fixed Shelf (1)
- Confirmat Screws (4)
- Screw Covers (4)

Assemble the fixed shelf. Ensure the shelf is near the top side of the cabinet.

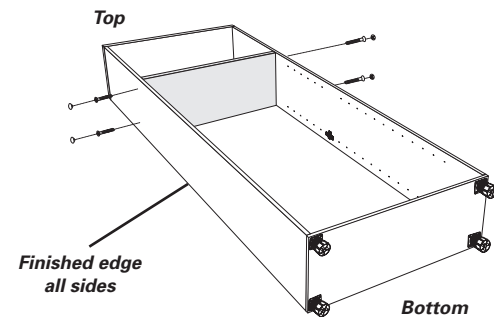
**STEP 6****Parts Required**

- Shelf Support Pins (8)

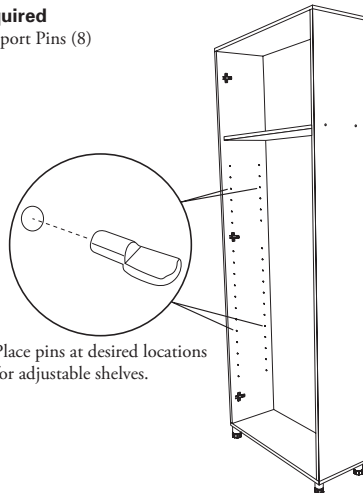
**Door Assembly Instructions****STEP 8****Parts Required**

- Hinges (6)

Install hinges to hinge plates. Repeat for other side.

Center hinge plate screw in hinge slot.

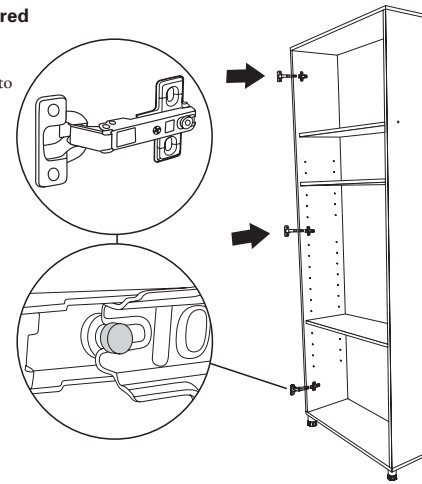
**STEP 11****Parts Required**

- Hinge Plate Screws (12)
- Door Pads (4)

Assemble doors to the cabinet.

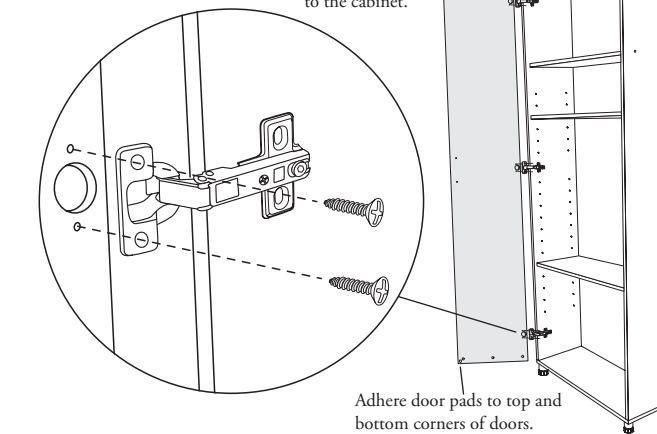
**STEP 13****Parts Required**

- Wall Attachment Bracket (1)
- Pan Head Screw (1)
- Wall Mount Screw (1)
- Wall Spacer (1)

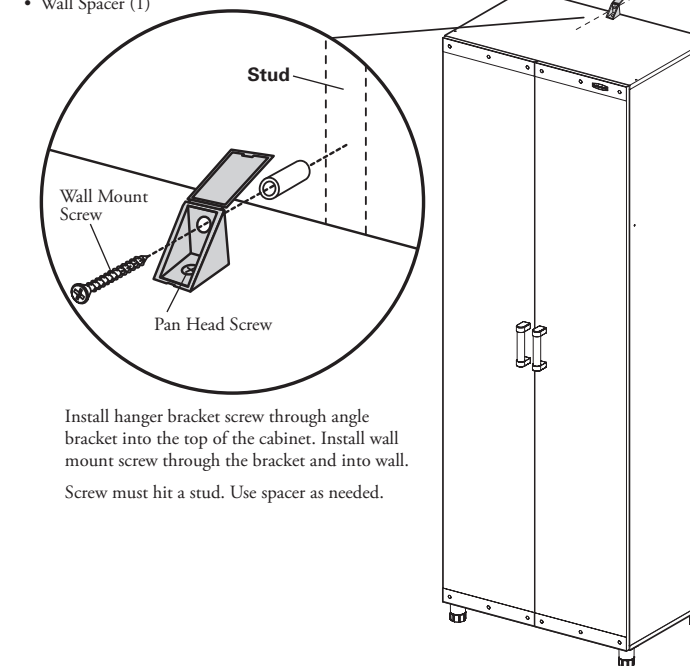
**STEP 9****Parts Required**

- Doors (2)
- Metal Plates (4)
- Metal Plate Fasteners with Screws (12)

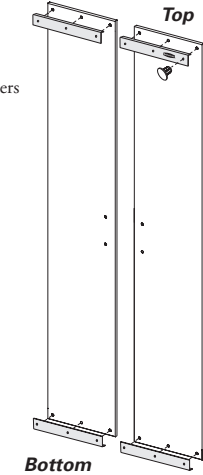
**STEP 10****Parts Required**

- Handles (2)
- Handle Screws (4)

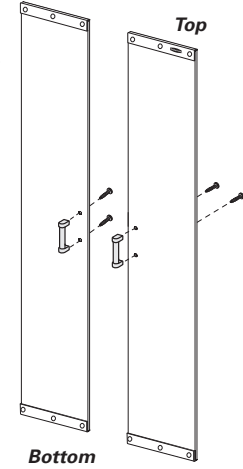
**STEP 12****Floor Mounting Adjustable Feet**

Place cabinet in desired location against wall. Level cabinet using adjustable feet.

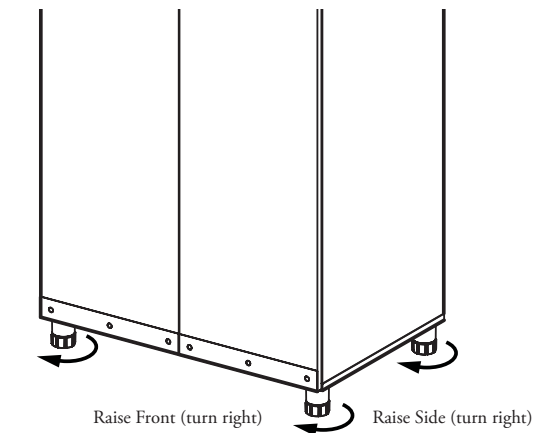

Ensure cabinet is square prior to adjusting hinges.

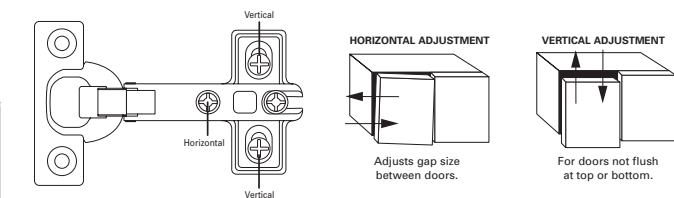
**Load Capacity**