

Safety Rules



This is the safety alert symbol. It is used to alert you to potential personal injury hazards. Obey all safety messages that follow this symbol to avoid possible injury or death.

Read and understand all safety rules and operating instructions before using this tractor attachment.

Follow all safety rules and operating instructions provided by your tractor's manufacturer when using attachment.

Never allow children or untrained persons to operate tractor or attachment.

Reduce tractor speed to slowest setting when towing or operating on slopes.

Operate up and down slopes, never across the face of slopes.

Do not carry passengers on tractor or attachment.

Avoid sudden turns or maneuvers.

Use caution when backing up to prevent damaging attachment.

Do not tow attachment on public roadways.

Do not remove warning decals from product.

Check product for worn, loose, or damaged parts before each use. If any damage is present, repair the product before using.

Check product for loose or missing fasteners before each use. Tighten or replace fasteners as needed before using.

Do not fasten rope to any part of your body or clothing.

Do not hold rope while tractor and Lawn Sweeper are in motion.

Do not use Lawn Sweeper near fire or smoldering debris.

Always fasten rope to tractor to avoid contact with wheels and brushes.

Always empty hopper before storing to avoid spontaneous combustion of contents.

Do not exceed tractor speed of 6 miles per hour when towing or operating Lawn Sweeper.

Carton Contents

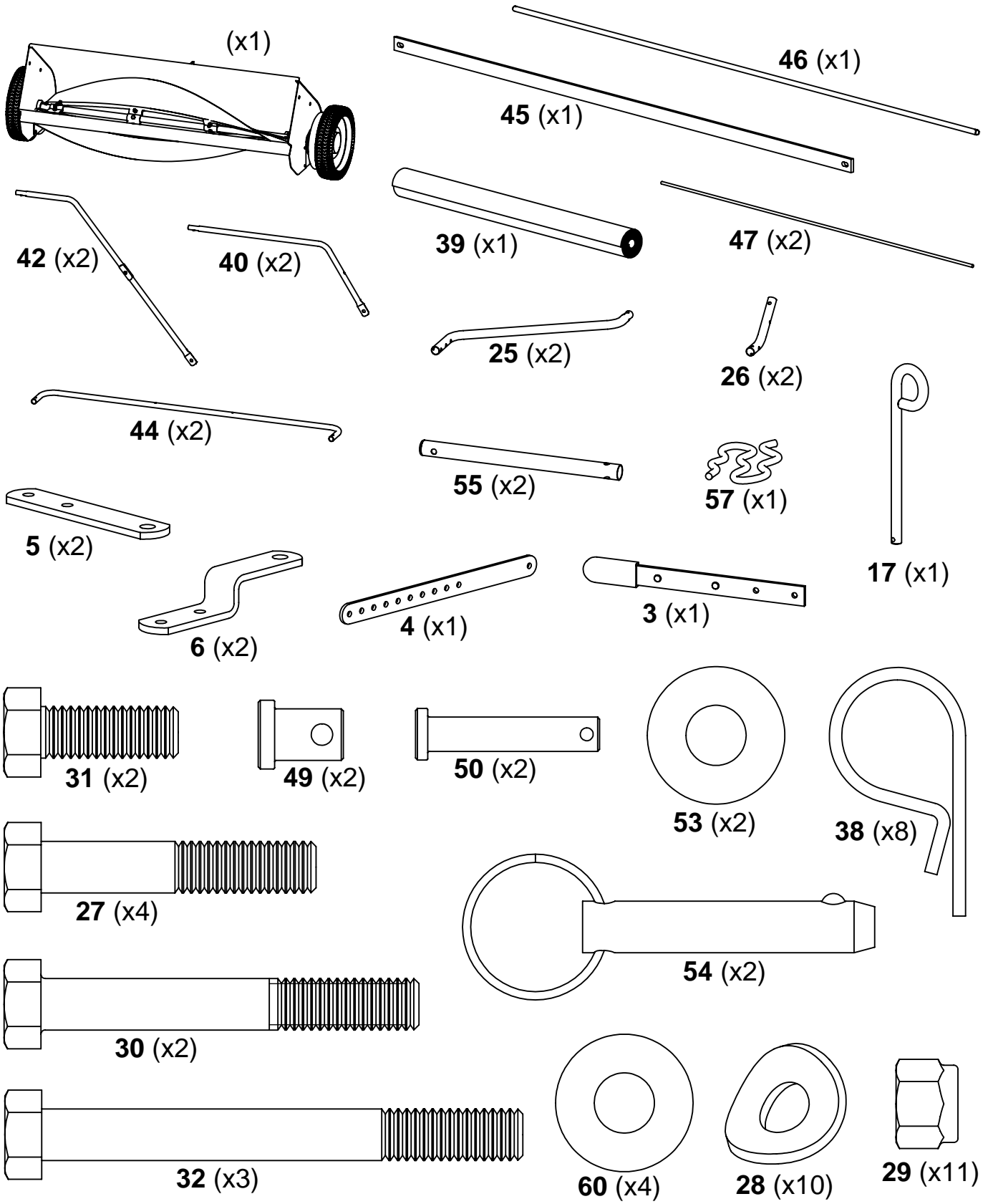

TOOLS REQUIRED FOR ASSEMBLY:

- 9/16" Wrench and Socket

Assembly Instructions

1

Attach Short Hitch Tubes to Sweeper Assembly and tighten hardware.

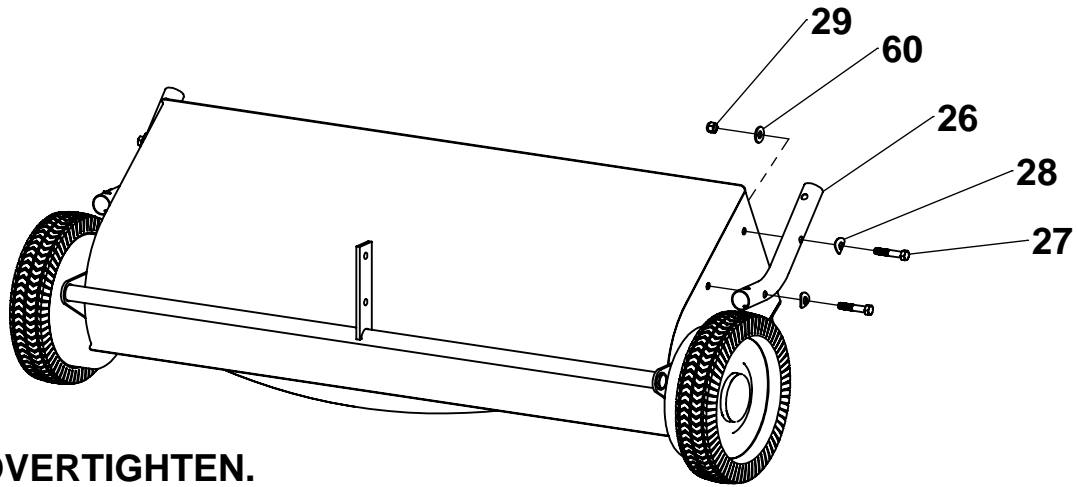

DO NOT OVERTIGHTEN.

2

Attach Handle to Height Adjustment and tighten hardware.

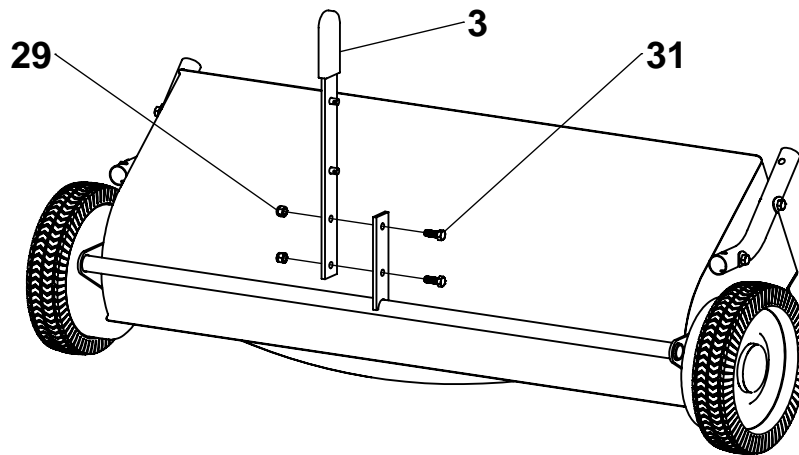

3

Insert Long Hitch Tubes into Short Hitch Tubes and snap into position.

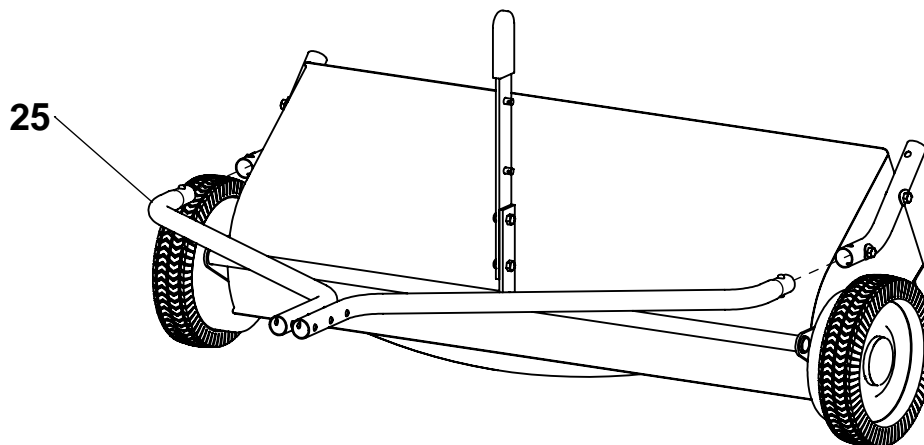

Assembly Instructions

4

Install hardware through front two holes of Long Hitch Tubes as shown. Hold Adjustment Lever in position and install third bolt as shown. Pin Adjustment Lever to Handle.

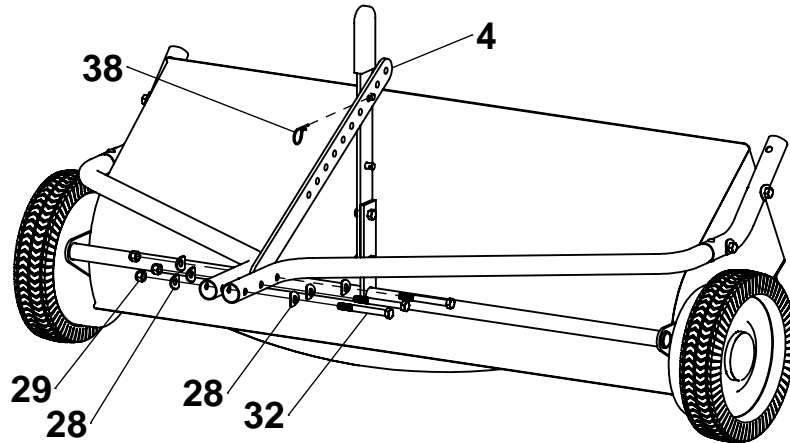

**DO NOT TIGHTEN
AT THIS TIME.**

5

Install Clevis Bars as shown; Clevis bolts pass between Hitch Tube bolts. Tighten Hitch Tube hardware first, then tighten Clevis hardware.

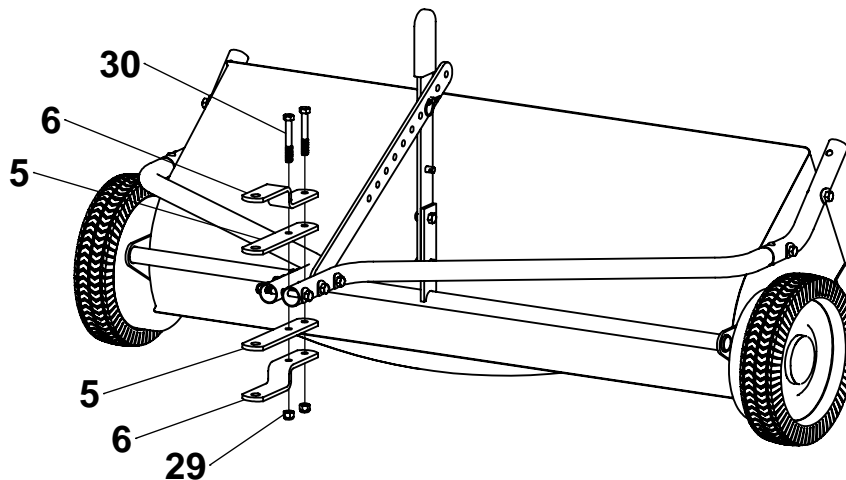

6

Insert Bottom Frame Tubes into Rear Frame Tube and snap into position.

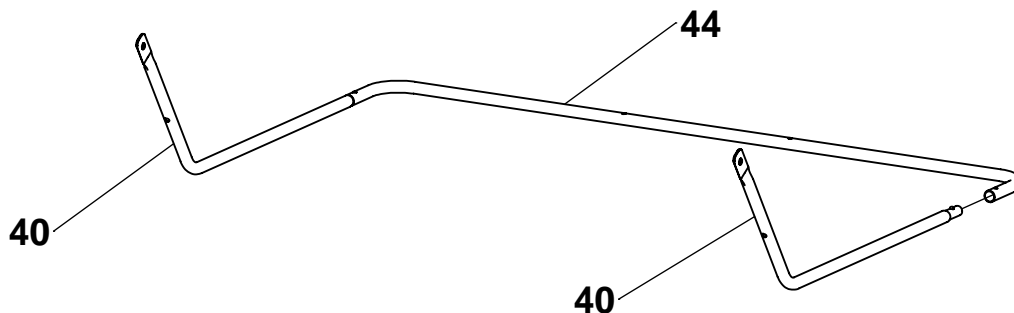

Assembly Instructions

- 7** Slide Hopper Bar into pocket of Hopper Bag as shown.

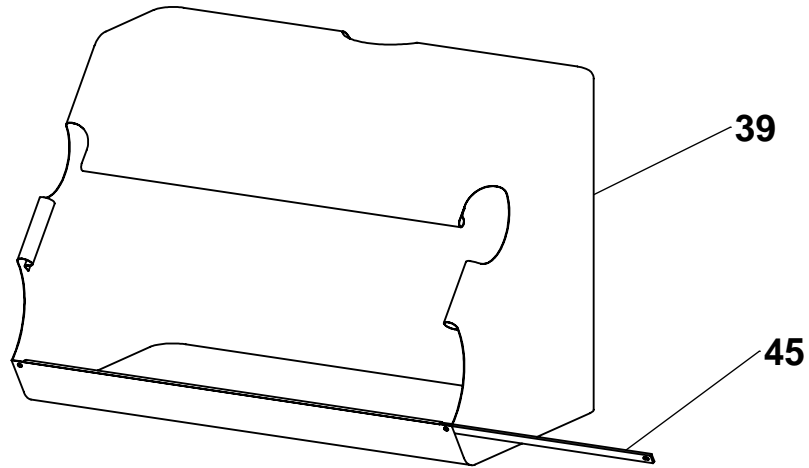

- 8** Place bottom frame assembly into Hopper Bag. Install Clevis Pins through Hopper Bag, Hopper Bar, and Bottom Frame Tubes and secure with Hairpins.

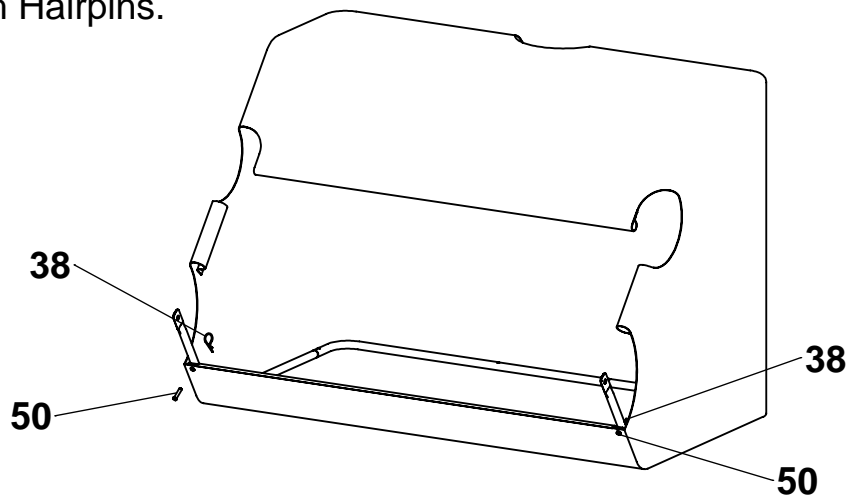

- 9** Insert Top Frame Tubes into Rear Frame Tube and snap into position.

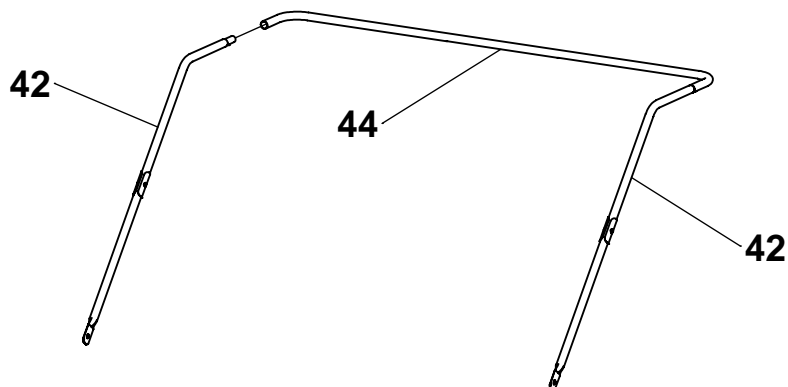

Assembly Instructions

- 10** Place top frame assembly into Hopper Bag.
Install Clevis Pins through Top Frame Tubes and Bottom Frame Tubes
and secure with Hairpins.

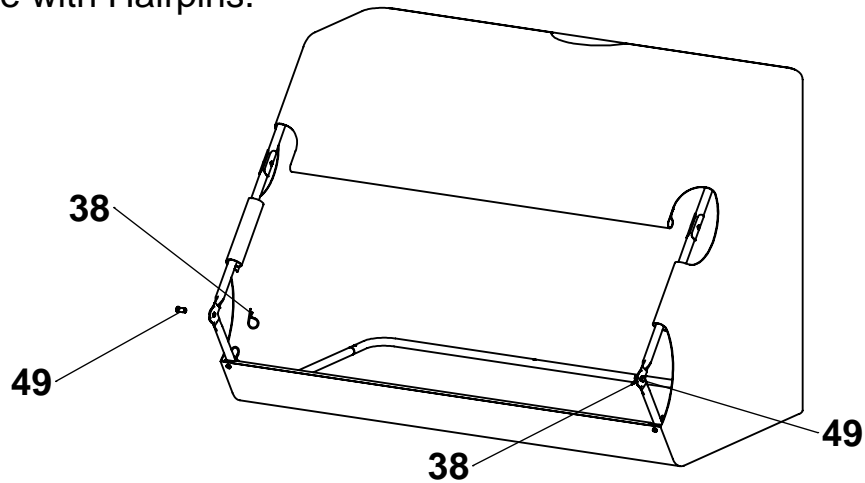

- 11** Slide Pivot Rod through Top Frame Tube and Connecting Tube, then through pocket of Hopper Bag, then through Connecting Tube and Top Frame Tube. Secure both ends with Washer and Hairpin.

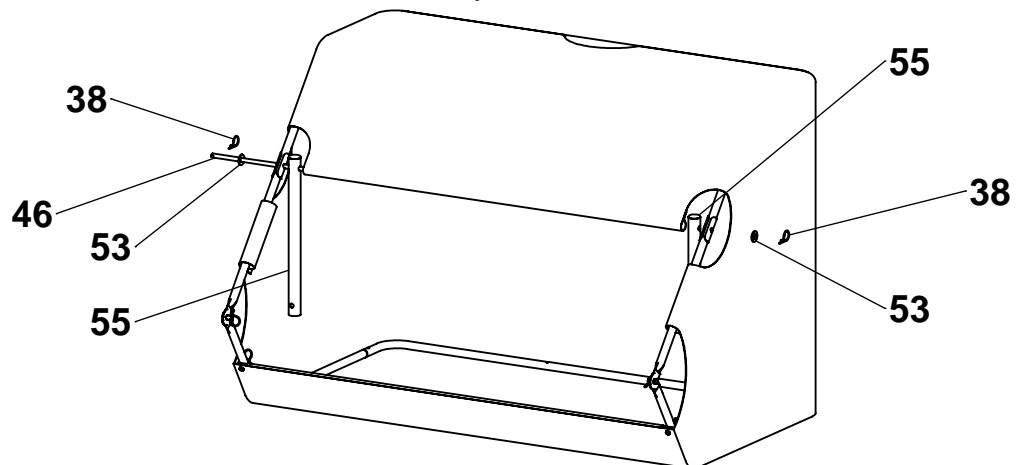

- 12** Hold Hopper Bag open and carefully insert Tension Rods into holes in
Rear Frame Tubes.
Secure Hopper Bag around Top Frame Tubes with velcro tabs.

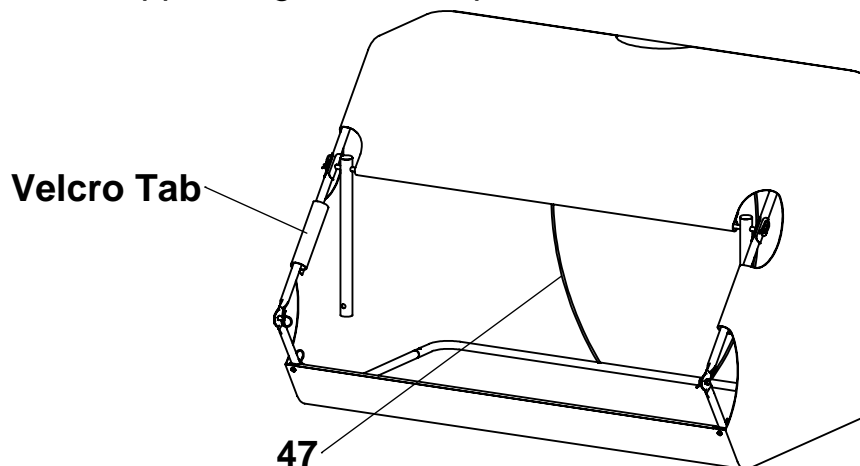

Assembly Instructions

13

Insert Connecting Tubes into Short Hitch Tubes and secure with Quick-Release Pins.
Install Hitch Pin and secure with Hairpin.

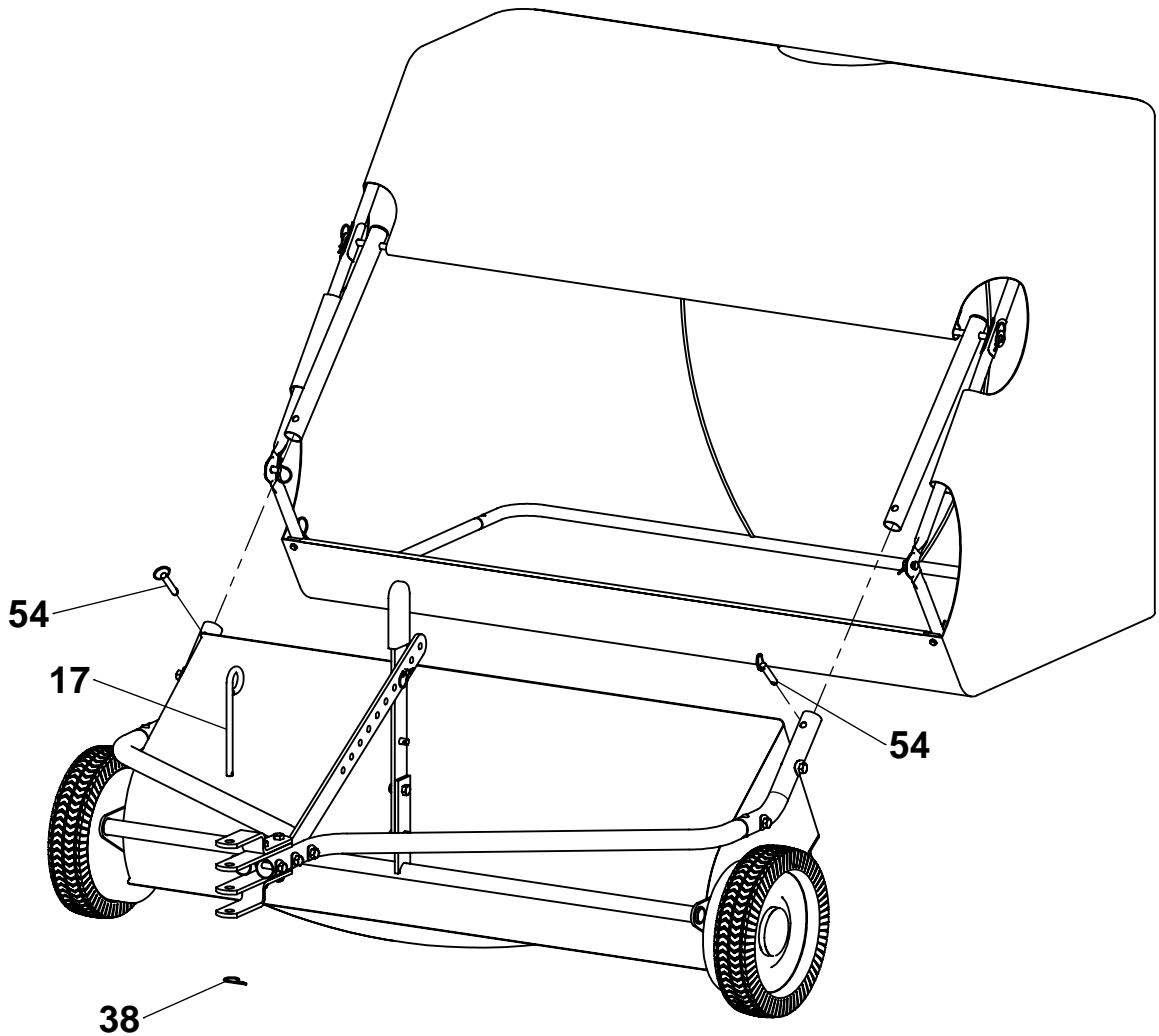

14

Tie Dump Rope securely around exposed section of Rear Frame Tube.

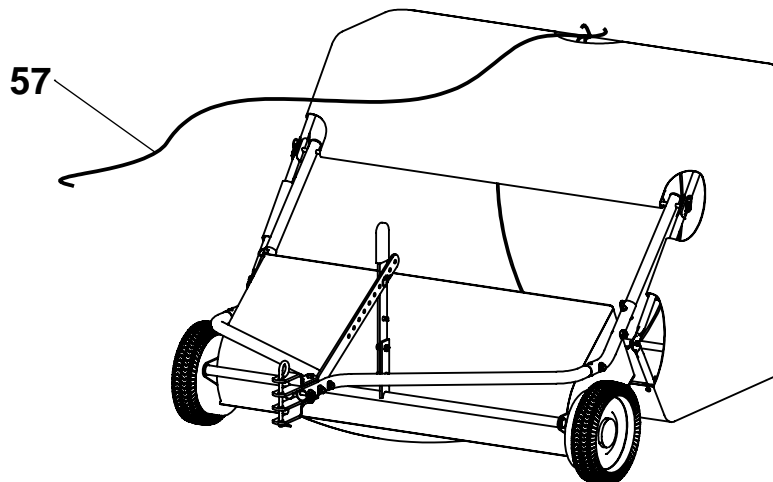

Operating Instructions

Before Using Lawn Sweeper:

1. Read all Safety Rules found on page 1.

How to Sweep Lawn:

1. Remove large debris from lawn.
2. Do not sweep if conditions are too wet or muddy.
3. Attach Lawn Sweeper to tractor using supplied hitch pin. The multi-pronged hitch allows the Lawn Sweeper to accommodate varying tractor hitch heights; choose the appropriate setting so that Lawn Sweeper hitch tubes are roughly level with the ground.
4. Attach dump rope to tractor so that it cannot contact the brushes or wheels.
5. Start tractor engine and tow Lawn Sweeper to lawn.
6. Adjust brush height so that brushes extend roughly 1/2" below the tips of the grass. For best performance, always set the brushes as high as possible to minimize resistance on brushes and wheels.
7. Engage tractor drive at its slowest speed and begin sweeping. Increase tractor speed as required to throw material to the back of the hopper bag.
8. Sweep in straight lines whenever possible and avoid sharp turns.
9. Periodically check the sweeper while operating to ensure that wheels and brushes are rotating smoothly and that nothing is wrapped around the brushes or brush shaft.
10. When filled, the hopper bag can be emptied by pulling the dump rope forward.

How to Adjust Brush Height:

1. Remove hairpin and detach adjustment lever from handle.
2. Move handle downwards to raise the brush height or upwards to lower the brush height.
3. Align the handle pin with the nearest hole in the adjustment lever. Use the top or bottom pin on the handle, whichever provides the best alignment.
4. Secure adjustment lever to handle with hairpin.

Operating Instructions

Storing Lawn Sweeper:

1. Empty hopper bag and thoroughly clean Lawn Sweeper before storing.
2. Store Lawn Sweeper away from excessive heat to prevent damage.
3. Brushes must not contact ground during storage to prevent damage.
4. Remove quick-release pins to separate hopper bag from Lawn Sweeper.
5. Carefully remove tension rods and collapse hopper bag for compact storage.
6. Detach adjustment lever from handle and depress snap buttons to remove hitch tubes from Lawn Sweeper for compact storage.

Periodic Maintenance:

- Tighten fasteners as needed before each use
- Empty hopper and thoroughly clean Lawn Sweeper after each use
- Remove any materials that have wrapped around brushes or brush shaft after each use
- Lubricate wheel bearings and gears annually with a light coating of grease

Warranty

If this product fails due to a defect in material or workmanship within TWO YEARS from the date of purchase, we will at our option repair or replace it free of charge. This warranty excludes tires, wheels, brushes and bag, which are expendable and become worn during normal use.

This warranty does not cover:

- Repairs necessary because of operator abuse or negligence.
- Equipment used for commercial or rental purposes.
- Paint that is worn or faded due to normal use or exposure.

To arrange for product repair call 1-800-652-2321, or return this product to place of purchase for replacement.

This warranty gives you specific legal rights, and you may also have other rights which may vary from state to state. This warranty applies only while this product is in use in the United States.

In the space below record the purchase date of your Lawn Sweeper.

Model Number **50SWP26** _____

Purchase Date _____

Keep this Owner's Manual and your receipt in a safe place for future reference.

After the two year warranty period all replacement parts may be ordered by calling **1-800-652-2321**.

When ordering replacement parts, always give the following information:

- Product **26 cu ft LAWN SWEEPER** _____
- Model Number **50SWP26** _____
- Part Number _____
- Part Description _____

Repair Parts

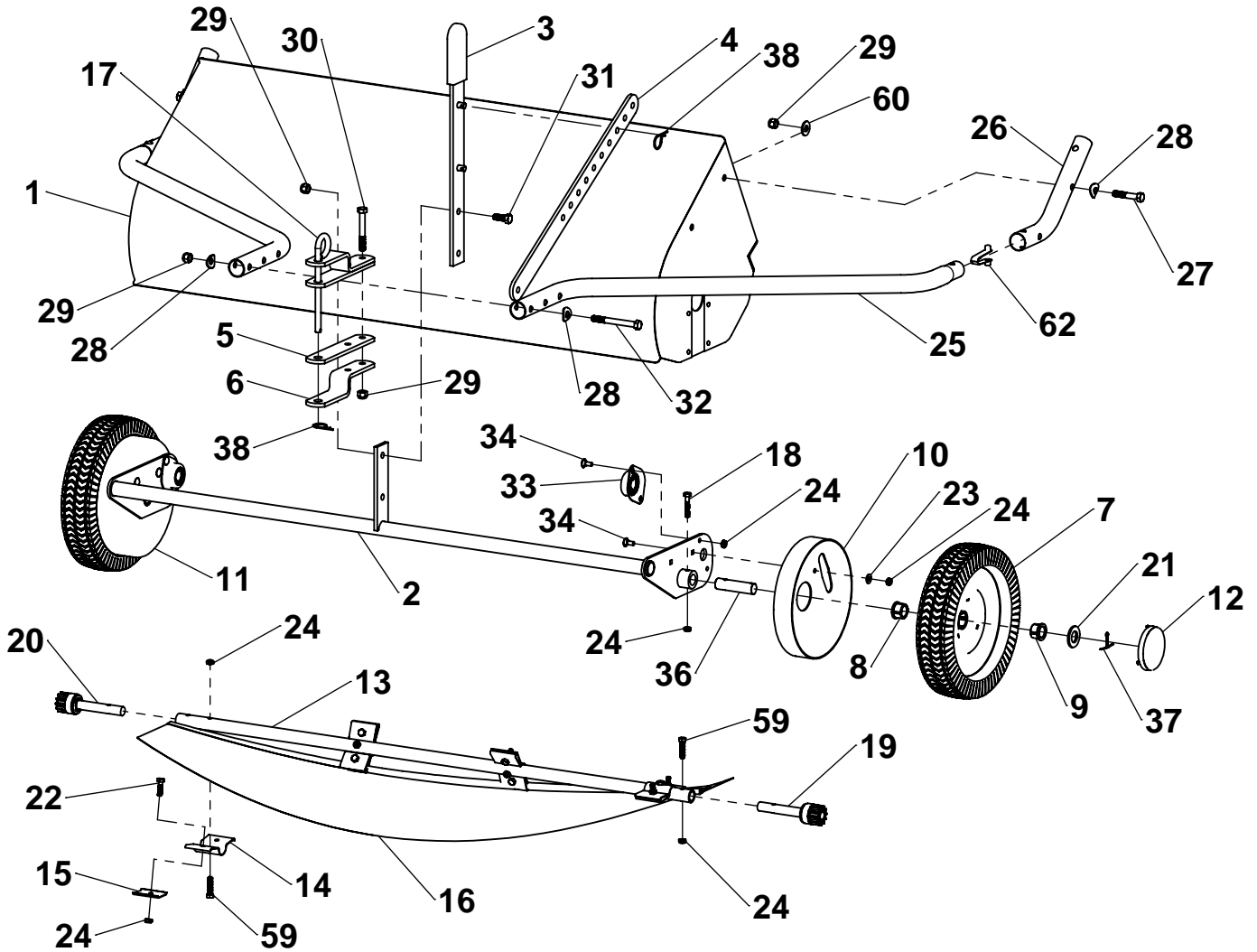

ITEM	PART NO	DESCRIPTION	QTY	ITEM	PART NO	DESCRIPTION	QTY
1	6000206	Sweeper Housing	1	21	3000721	3/4" SAE Flat Washer	2
2	307119	Height Adjustment (incl 36)	1	22	6000192	1/4-20 x 1" Hex Bolt	8
3	307181	Handle	1	23	3000716	1/4" USS Flat Washer	4
4	307113	Adjustment Lever	1	24	300065	1/4-20 Nyloc Nut	24
5	307042	Clevis Bar, Flat	2	25	307038	Hitch Tube, Long	2
6	307043	Clevis Bar, Offset	2	26	307034	Hitch Tube, Short	2
7	307011	Wheel (incl 8 & 9)	2	27	3000543	3/8-16 x 2" Hex Bolt	4
8	307212	Wheel Bushing, Inner	2	28	3000722	3/8" USS Curved Washer	10
9	307211	Wheel Bushing, Outer	2	29	310061	3/8-16 Nyloc Nut	11
10	307101	Dust Cover, Left	1	30	310051	3/8-16 x 2-3/4" Hex Bolt	2
11	307102	Dust Cover, Right	1	31	3000533	3/8-16 x 1" Hex Bolt	2
12	307241	Hub Cap	2	32	3000544	3/8-16 x 3-1/2" Hex Bolt	3
13	307125	Brush Axle	1	33	307022	Bearing Assembly	2
14	307122	Brush Bracket	4	34	3000540	1/4-20 x 5/8" Carriage Bolt	8
15	307121	Brush Clamp	8	36	307002	Wheel Axle	2
16	307322	Brush	2	37	300081	Cotter Pin, 1/8" x 1-1/2"	2
17	307082	Hitch Pin	1	38	307083	Hairpin	2
18	3000542	1/4-20 x 1-1/2" Hex Bolt	2	59	3000539	1/4-20 x 1-1/4" Hex Bolt	6
19	307320	Pinion Assembly, Left	1	60	310073	3/8" USS Flat Washer	4
20	307319	Pinion Assembly, Right	1	62	6000222	Snap Button	2

Repair Parts

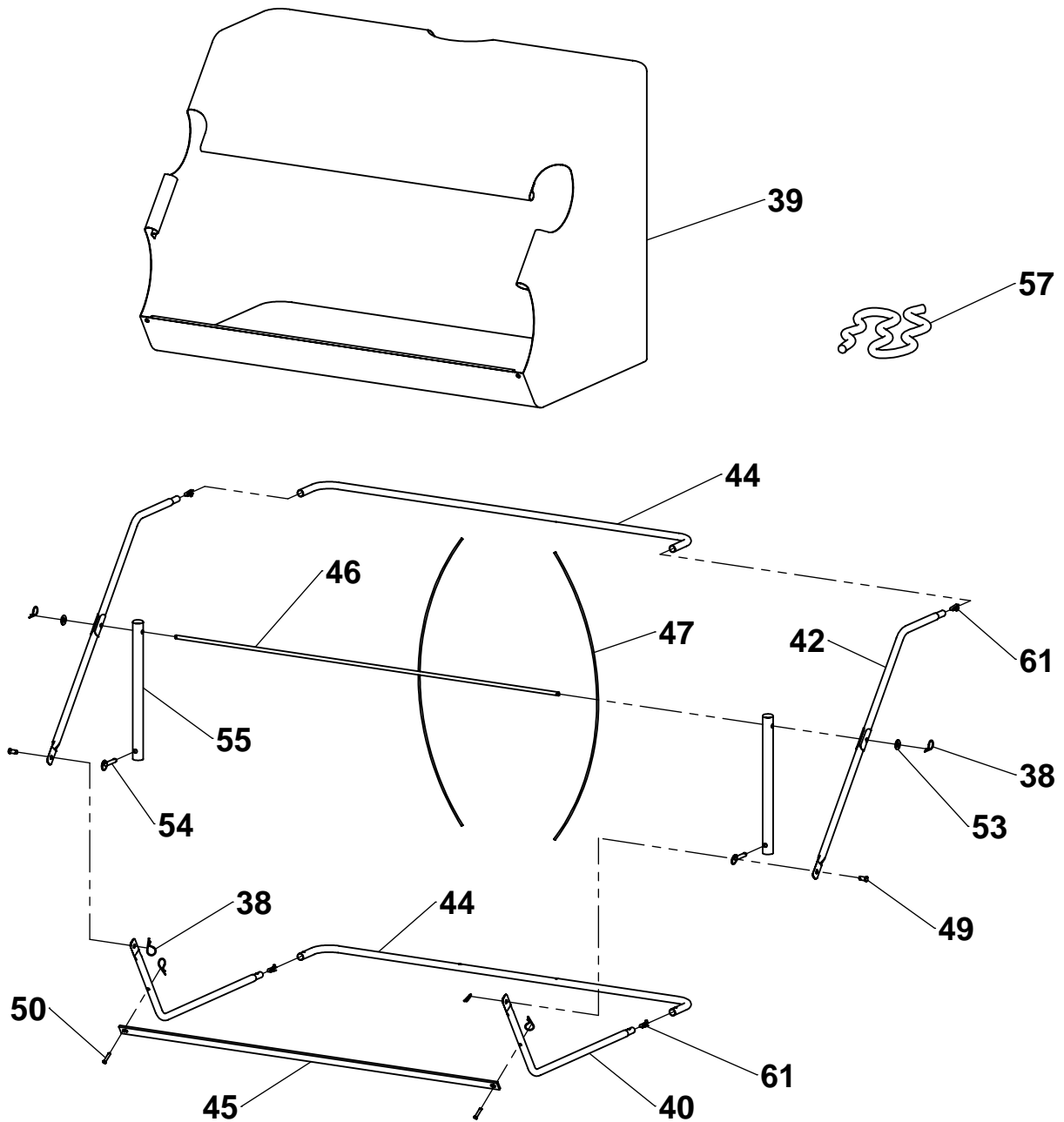

ITEM	PART NO	DESCRIPTION	QTY	ITEM	PART NO	DESCRIPTION	QTY
38	307083	Hairpin	6	49	3000818	Clevis Pin, 3/8" x 1/2"	2
39	307332	Hopper Bag	1	50	3000820	Clevis Pin, 1/4" x 1-1/4"	2
40	6000285	Bottom Frame Tube (incl 61)	2	53	3000720	3/8" USS Flat Washer	2
42	6000284	Top Frame Tube (incl 61)	2	54	3000823	Quick-Release Pin	2
44	6000287	Rear Frame Tube	2	55	307032	Connecting Tube	2
45	307062	Hopper Bar	1	57	307361	Dump Rope	1
46	307053	Pivot Rod	1	61	6000208	Snap Button	4
47	307052	Tension Rod	2				

www.ohiosteel.com
(800) 652-2321