



Operating Instructions and Parts Manual 5-inch x 8-inch Horizontal Band Saw

Models: J-3130, J-3230



Model J-3230 shown

JET
427 New Sanford Road
LaVergne, Tennessee 37086
Ph.: 800-274-6848
www.jettools.com

Part No. M-414453
Revision F1 01/2016
Copyright © 2015 JET



1.0 IMPORTANT SAFETY INSTRUCTIONS

General Cautions

- Misuse of this machine can cause serious injury.
- For safety, the machine must be set up, used and serviced properly.
- Read, understand and follow the instructions in the operator's and parts manual which was shipped with your machine.

When setting up the machine:

- Always avoid using the machine in damp or poorly lighted work areas.
- Always be sure the machine is securely anchored to the floor or the work bench.
- Always keep the machine guards in place.
- Always put the start switch in the "OFF" position before plugging in the machine.

When using the machine:

- Never operate the machine with safety guards missing.
- Always wear safety glasses with side shields (See ANSI Z87.1)
- Never wear loose clothing or jewelry.
- Never overreach; you may slip and fall into the machine.
- Never leave the machine running while unattended.
- Always shut the machine off when not in use.

When servicing the machine:

- Always unplug the machine from the electrical power before servicing.
- Always follow the instructions in the operators and parts manual when changing accessory tools or parts.
- Never modify the machine without consulting Walter Meier (Manufacturing) Inc.

You — the stationary power tool user — hold the key to safety.

Read and follow these simple rules for best results and full benefits from your machine. Used properly, JET machinery is among the best in design and safety. However, any machine used improperly can be rendered inefficient and unsafe. It is mandatory that those who use our products be properly trained in how to use them correctly. They should read and understand the Operator's and Parts Manual as well as all labels affixed to the machine. Failure in

following all of these warnings can cause serious injuries.

General Machinery Warnings

1. Always wear protective eye wear when operating machinery. Eye wear shall be impact resistant, protective safety glasses with side shields which comply with ANSI Z87.1 specifications. Use of eye wear which does not comply with ANSI Z87.1 specifications could result in severe injury from the breakage of the eye protection.
2. Wear proper apparel. No loose clothing or jewelry which can get caught in moving parts. Rubber soled, nonslip, footwear is recommended for best footing.
3. Do not overreach. Failure to maintain a proper working position can cause you to fall into the machine or cause your clothing to get caught — pulling you into the machine.
4. Keep guards in place and in proper working order. Do not operate the machine with the guards removed.
5. Avoid dangerous working environments. Do not use stationary machine tools in wet or damp locations. Keep work areas clean and well lit.
6. Special electrical precautions should be taken when working on flammable materials.
7. Avoid accidental starts by being sure that the start switch is in the "OFF" position before plugging in the machine.
8. Never leave the machine running while unattended. The machine shall be shut off whenever it is not being used.
9. Disconnect the electrical power before servicing, whenever changing accessories or when general maintenance is done on the machine.
10. Maintain all machine tools with care. Follow all maintenance instructions for lubricating and the changing of accessories. No attempt shall be made to modify or have makeshift repairs done to the machine. This not only voids the warranty but also renders the machine unsafe.
11. If there is any risk of tipping or sliding, the machinery must be anchored to the floor.
12. Secure your work. Use clamps or a vise to hold your work, when practical. It is safer than using your hands and it frees both hands to operate the machine.
13. Never brush chips away while the machine is in operation.
14. Keep work area clean. Cluttered areas invite accidents.
15. Remove adjusting keys and wrenches before turning the machine on.

16. Use the right tool. Don't force a tool or attachment to do a job for which it was not designed.
17. Use only recommended accessories and follow manufacturer's instructions pertaining to them.
18. Keep hands in sight and clear of all moving parts and cutting surfaces.
19. All visitors should be kept at a safe distance from the work area. Make your workshop completely safe by using padlocks, master switches, or by removing starter keys.
20. Know the tool you are using; its application, limitations, and potential hazards.

General Electrical Cautions

This machine should be grounded in accordance with the National Electrical Code and local codes and ordinances. The work should be done by a qualified electrician. The machine should be grounded to protect the user from electrical shock.

Wire Sizes

CAUTION: For circuits that are a great distance from the electrical service box, the wire size must be increased in order to deliver ample voltage to the motor. To minimize power losses and to prevent motor overheating and burnout, the use of wire sizes for branch circuits or electrical extension cords according to the following table is recommended:

Conductor length	AWG (American Wire Gauge) number	
	240 volt lines	120 volt lines
0-50 feet	No. 14	No. 14
50-100 feet	No. 14	No. 12
Over 100 feet	No. 12	No. 8

Table 1

Safety Instructions on Sawing Systems

1. Always wear leather gloves when handling saw blade. The operator shall not wear gloves when operating the machine.
2. All doors shall be closed, all panels replaced, and other safety guards in place prior to the machine being started or operated.

3. Be sure that the blade is not in contact with the workpiece when the motor is started. The motor shall be started and you should allow the saw to achieve full speed before bringing the saw blade into contact with the workpiece.
4. Keep hands away from the blade area.
5. Remove any cut off piece carefully while keeping your hands free of the blade area.
6. Saw must be stopped and electrical supply must be cut off before any blade replacement or adjustment of blade support mechanism is done, or before any attempt is made to change the drive belts or before any periodic service or maintenance is performed on the saw.
7. Remove all loose items and unnecessary workpieces from the area before starting machine.
8. Bring adjustable saw guides and guards as close as possible to the workpiece.
9. Always wear protective eye wear when operating, servicing, or adjusting machinery. Eyewear shall be impact resistant, protective safety glasses with side shields complying with ANSI Z87.1 specifications. Use of eye wear which does not comply with ANSI Z87.1 specifications could result in severe injury from breakage of eye protection.
10. Nonslip footwear and safety shoes are recommended.
11. Wear ear protectors (plugs or muffs) during extended periods of operation.
12. The workpiece, or part being sawed, must be securely clamped before the saw blade enters the workpiece.
13. Remove cut off pieces carefully, keeping hands away from saw blade.
14. Saw must be stopped and electrical supply disconnected before reaching into cutting area.
15. Avoid contact with coolant, especially guarding your eyes.

Familiarize yourself with the following safety notices used in this manual:

CAUTION This means that if precautions are not heeded, it may result in minor injury and/or possible machine damage.

WARNING This means that if precautions are not heeded, it may result in serious injury or possibly even death.

2.0 Table of contents

Section	Page
1.0 IMPORTANT SAFETY INSTRUCTIONS	2
2.0 Table of contents.....	4
3.0 About this machine and manual	5
4.0 Features and Nomenclature.....	5
5.0 Specifications	6
6.0 Set-up and assembly	7
6.1 Shipping contents.....	7
6.2 Tools required for assembly	7
6.3 Unpacking and cleanup.....	7
6.4 Assembling the band saw	8
6.5 Installing coolant kit	9
7.0 Electrical connections	9
7.1 Wiring diagram	10
8.0 Operating Instructions	10
8.1 Clamping materials in the vise	10
8.2 Right angle cutting.....	10
8.3 Angle cutting.....	10
8.4 Clamping methods	11
8.5 Using the stock stop	11
8.6 Blade selection	11
8.7 Changing blade speeds.....	12
8.8 Evaluating cutting efficiency	12
8.9 Cutting procedure	12
8.10 Using the hydraulic feed control	12
8.11 Blade break-in procedures	13
8.12 Changing blades	13
9.0 Maintenance.....	14
9.1 Motor replacement	14
9.2 Adjusting guide bearings	14
9.3 Blade tracking.....	14
9.4 Replacing guide bearings.....	15
9.5 Adjusting back-up bearings	15
9.6 Adjusting the arm stop adjustment bolt	15
9.7 Adjusting motor switch actuator	15
9.8 Replacing a back up bearing.....	16
9.9 Adjusting the bearing guide seats for blade vertical.....	16
9.10 Test cutting to verify adjustment accuracy	16
10.0 Maintenance Chart	17
11.0 Troubleshooting the J-3130 and J-3230	18
12.0 Replacement Parts.....	21
12.1.1 J-3130/3230 Lower Saw Head – Exploded View	22
12.1.2 J-3130/3230 Lower Saw Head – Parts List	23
12.2.1 J-3130/3230 Upper Saw Head – Exploded View	24
12.2.2 J-3130/3230 Upper Saw Head – Parts List	25
12.3.1 J-3130/3230 Saw Base – Exploded View	26
12.3.2 J-3130/3230 Saw Base – Parts List	27
12.4.1 J-3130/3230 Stand and Coolant System – Exploded View.....	28
12.4.2 J-3130/3230 Stand and Coolant System – Parts List.....	29
13.0 Warranty and Service.....	30

3.0 About this machine and manual

The JET 5"x8" Band Saw is available as a dry cutting saw or a wet cutting saw. If required, a dry cutting band saw can be retrofitted with a kit which converts it to use with cutting fluids. The use of a hydraulic feed delivers consistent, accurate cuts and longer blade life.

This manual is provided by JET covering the safe operation and maintenance procedures for a JET Model J-3130 and J-3230 Band Saw. This manual contains instructions on installation, safety precautions, general operating procedures, maintenance instructions and parts breakdown. Your machine has been designed and constructed to provide consistent, long-term operation if used in accordance with the instructions as set forth in this document.

If there are questions or comments, please contact your local supplier or JET. JET can also be reached at our web site: www.jettools.com.

Retain this manual for future reference. If the machine transfers ownership, the manual should accompany it.

⚠WARNING Read and understand the entire contents of this manual before attempting assembly or operation! Failure to comply may cause serious injury!

4.0 Features and Nomenclature

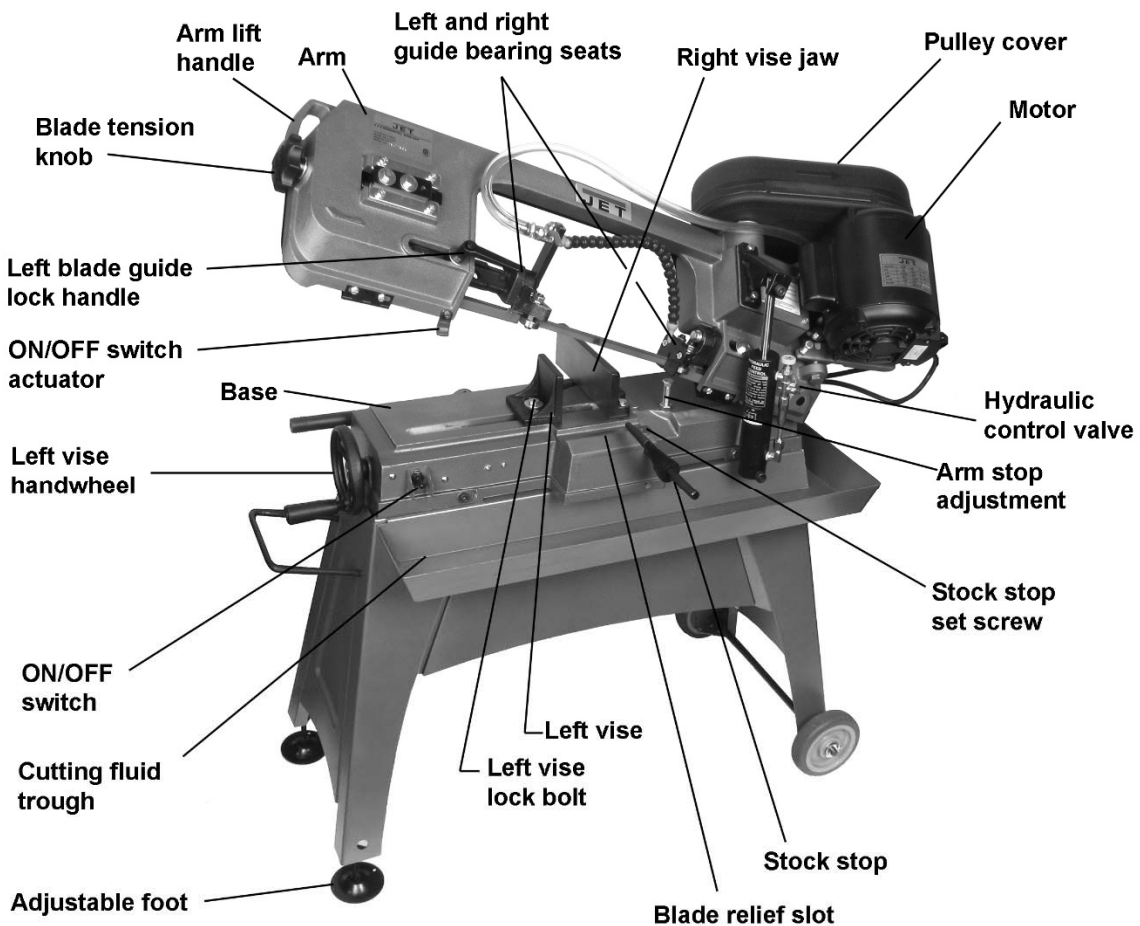

Figure 1: Features and nomenclature

5.0 Specifications

Model numbers.....	J-3130	J-3230
Stock numbers.....	414461	414453
Type.....	dry	wet

Motor and electricals:

Motor type	totally enclosed fan cooled, induction, capacitor start
Horsepower	1/2 HP
Phase.....	single
Voltage.....	115/230V (prewired 115V)
Cycle.....	60Hz
Listed FLA (full load amps).....	9/4.5
Starting amps	44 A
Running amps (no load).....	7.2A
Start capacitor	200 MFD, 125 VAC
Power transfer	belt
On/off switch	toggle switch
Motor speed	1725 RPM
Power cord length.....	6.4 ft. (195cm)
Power plug installed.....	120V
Recommended circuit size ¹	15A
Sound emission.....	70 dB at 40" (1m) from blade, without load

Wet cutting package - coolant pump (optional)..... single phase, 120V

¹ subject to local/national electrical codes.

Capacities:

90° Cutting (Round)	5" (127mm)
90° Cutting (Rectangle).....	7-1/2"w x 5"h (190 x 127mm)
90° Cutting (Flat Stock).....	8"w x 1"h (200 x 25.4mm)
45° Cutting (Round)	4-3/4" (120mm)
45° Cutting (Rectangle).....	4-3/4"w x 5"h (120 x 127mm)
Blade speeds.....	85,120,200 SFM
Wet cutting tank (optional).....	1 gal (4.5L) capacity

Materials:

Table.....	cast iron, ground surface
Bow.....	cast iron
Stand	steel
Blade drive	steel, heat-treated worm driving a bronze worm gear in an oil bath
Side blade guides.....	ball bearings mounted on eccentric shafts (bearings sealed and permanently lubricated)
Rear blade guides.....	ball bearings, sealed and permanently lubricated
Band wheels.....	flanged cast iron

Dimensions:

Blade size	8/12T, 2" x 0.025" x 68"
Blade wheel diameter	7-3/8" (187mm)
Bed height from floor.....	23-1/2" (600mm)
Overall machine dimensions (arm horizontal).....	38"L x 16"W x 38"H (960 x 400 x 940mm)
Overall machine dimensions (arm vertical).....	38"L x 16"W x 58"H (960 x 400 x 1450mm)

Net weight	143 lbs. (65 kg)	160 lbs. (72.6 kg)
Shipping weight	148 lbs. (67 kg)	165 lbs. (75 kg)

The specifications in this manual were current at time of publication, but because of our policy of continuous improvement, JET reserves the right to change specifications at any time and without prior notice, without incurring obligations.

6.0 Set-up and assembly

WARNING Read and understand all assembly instructions before attempting assembly. Failure to comply may cause serious injury.

6.1 Shipping contents

See Figures 2 and 3.

- 1 Band saw (not shown)
 - 1 Work stop assembly – A
 - 1 Pulley cover – B
 - 1 Belt – C
 - 1 Handwheel – D
 - 1 Handle – E
 - 1 Axle – F
 - 1 Hydraulic cylinder – G
 - 2 Wheels – H
 - 2 Adjustable foot with nuts and washer – I
 - 1 Stand trough – J
 - 2 Stand cross braces – K
 - 1 Stand shelf – L
 - 1 Stand front panel – M
 - 4 Stand legs (2 LH, 2 RH) – N
- 1 Hardware package, includes:
- 1 Socket hd cap screw, 5/16 x 4 – HP1
 - 1 Socket hd cap screw, 3/8 x 1-1/4 – HP2
 - 5 Socket hd cap screws, 1/4 x 1-1/4 – HP3
 - 19 Phillips hd screws, 1/4 x 5/8 – HP4
 - 2 Cotter pins, 1/8x1 – HP5
 - 1 Hex nut, 5/16 – HP6
 - 24 Hex nuts, 1/4 – HP7
 - 24 Flat washers, 1/4 – HP8
 - 6 Flat washers, 5/8 – HP9

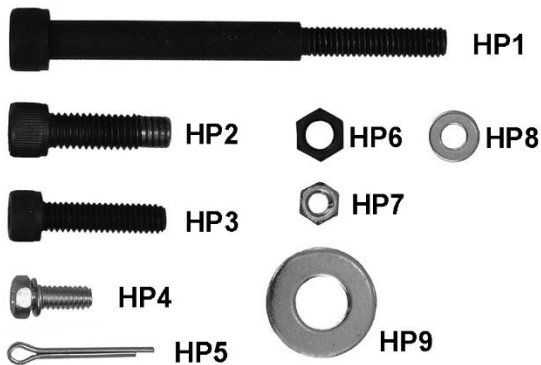

Figure 2
(Hardware package p/n J-3130G-HK)

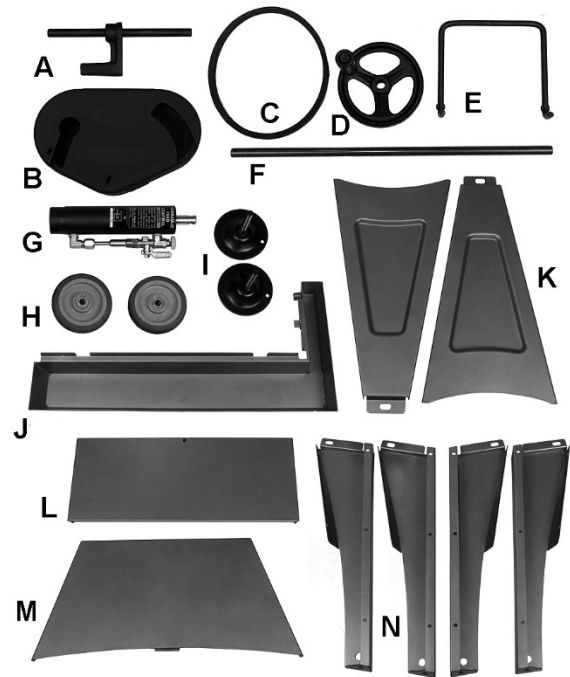

Figure 3

6.2 Tools required for assembly

Wrenches, 10/12mm
 Hex keys, 3/4/6/8 mm
 #2 cross point screwdriver
 Pliers
 (Note: Ratchets and sockets will speed assembly.)

6.3 Unpacking and cleanup

1. Inspect contents for shipping damage. Report damage, if any, to your distributor.
2. Compare contents of shipping carton with the contents list in this manual. Report shortages, if any, to your distributor.

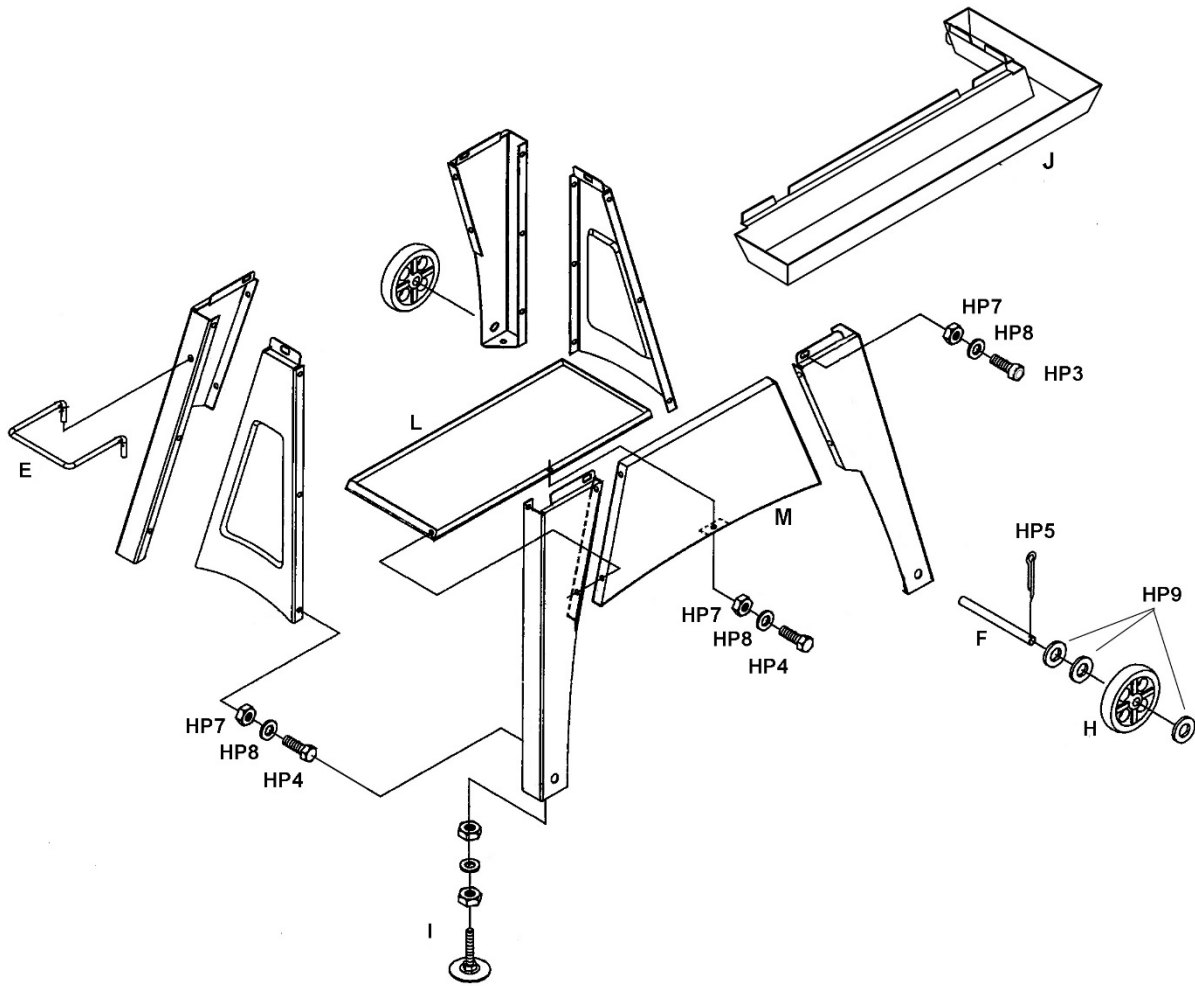

Figure 4

6.4 Assembling the band saw

Refer to Figures 4 through 7. If further clarification is needed, refer to exploded views in sect. 12.0.

NOTE: Only make fasteners hand-tight at this time. They will be fully tightened after band saw has been settled atop stand.

1. Assemble legs, cross braces, front panel and shelf, as shown in Figure 4.
2. Install handle (E) into end of assembled stand.
3. Install axle and wheels on right side of stand. Use two flat washers between wheel and stand leg on each side. Insert cotter pin (HP5) at each axle end and bend prongs to secure.
4. Install adjustable feet (I) at opposite end of stand and adjust until stand is level.
5. Install trough (J), making sure tab on trough engages slot on stand.
6. Use an assistant to help lift band saw onto stand, aligning the holes at the four corners with the holes in the stand.

7. Remove the fixed plate which secured the saw head for transport. Figure 5.

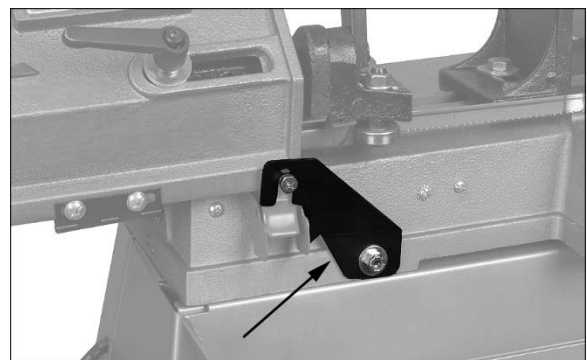

Figure 5

8. Install a 1/4 x 1-1/4 socket head cap screw with two flat washers and a hex nut in each of the holes that mount the saw to the stand. *Do not fully tighten yet.*
9. Align holes in bracket and hydraulic cylinder shaft, and secure with 3/8 x 1-1/4 socket head cap screw (HP2). See Figure 6.



Figure 6

10. Insert a 5/16 x 4 socket head cap screw through the hydraulic cylinder, and install a hex nut on the threaded end, as shown in Figure 6. Insert threaded end into hole in base casting. *Do not fully tighten yet.*
11. Tighten all screws and nuts securing the saw to the stand, and the screw on the hydraulic cylinder.
12. Tighten all hex nuts on stand assembly.

6.5 Installing coolant kit

Refer to sect. 12.4.1 for a complete view of the components in the coolant kit, and refer to *Figure 7* for the attachment of the valve to the valve bracket on the guide bearing seat.

1. Install the baffle in the tank so the pump is held at one end.
2. Install the 90 degree elbow and one of the hose fittings in the bottom of the coolant pump.
3. Install one end of the coolant hose on the pump fitting.
4. Install the pump on the tank and put the assembly into the tray underneath the saw base.
5. Install the valve, back end first, into the bracket (*Figure 7*).
6. Secure it with the set screw after being sure the handle can turn its full 1/4 turn.

7. Install the nozzle on the front of the valve, then install the hose fitting and hose on the back end of the valve.
8. Fill the tank with approximately one gallon of coolant.
9. Put the valve handle in OFF position – at right angle to the direction of flow through the valve.
10. Connect the pump to its electrical source.

Note: The pump cable is supplied with a standard plug for a 120V single phase grounded branch receptable. Always use a grounded receptable for this purpose.

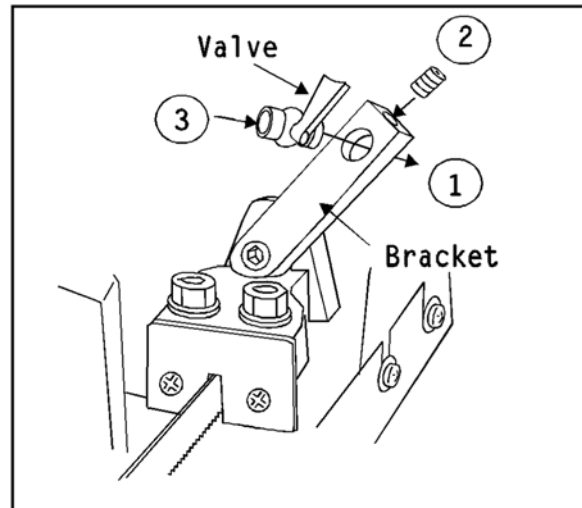

Figure 7: Installing valve in valve bracket

7.0 Electrical connections

Plug the saw into a suitable service branch. The saw is a 120V single phase motor and the motor cable has a standard 3-prong grounded plug installed.

WARNING Always connect the plug to a grounded branch circuit.

If local regulations require that the saw be permanently wired, or if the environment in which the saw is used makes this advisable, the connection should only be made by a licensed electrician who is familiar with all national and local electrical codes.

The service disconnect should have an external ON/OFF switch or lever which permits the saw operator to disconnect branch power to the saw during set-up and maintenance operations as described in this manual.

7.1 Wiring diagram

The motor standard on the saw is a 120V single phase, 1750RPM motor which can also be reconfigured for 240V operation. If the saw will be used on a 240V single phase branch circuit, the electrician will find a diagram for reconfiguring the motor wiring underneath the motor terminal plate.

The wiring diagram here is included for reference when replacing the motor, ON/OFF switch or cable. These operations should be performed only by a licensed electrician.

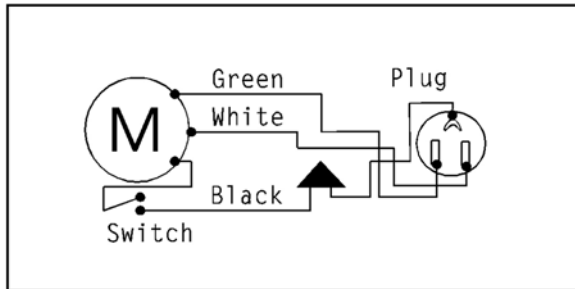

Figure 8: Wiring diagram

8.0 Operating Instructions

8.1 Clamping materials in the vise

Refer to Figure 1.

1. Lift the saw arm to its full up position.
2. Lock the arm up using the hydraulic feed control valve.

NOTE: Use the handle on the arm to lift the arm. Never use any other part of the arm as a lifting method.

3. Open the left vise by turning the vise handwheel counterclockwise.
4. Adjust the vise jaws for the appropriate cutting angle, if required. See sections on *Right angle cutting* and *Angle cutting*.
5. Put the work piece material between the vise jaws.

NOTE: If the work piece material is long, support both the ends of the material as needed to keep the material level on the saw base.

6. Turn the vise handwheel clockwise until the work piece is securely clamped in the vise.
7. Proceed to cut according to instructions in *Cutting procedure*.

8.2 Right angle cutting

Refer to Figures 1 and 9.

If you want to be certain the workpiece is being held in the vise at exactly 90 degrees to the blade

for cutoff work, use the following procedure to check the blade-to-jaw angle.

1. Disconnect the saw from its electric power source.
2. With the saw arm in its fully lowered position, place a machinist's square, or a machinist's protractor 90 degrees, against the saw blade and right vise jaw. If the jaw is square to the blade, then no adjustment is required.
3. If adjustment is required, see *Angle Cutting*. The procedure for setting the jaw angle with respect to the blade is described in that section.

8.3 Angle cutting

Refer to Figure 9.

1. Loosen the right jaw pivot and lock bolts.
2. With the arm in its fully lowered position, and using a machinist's protractor between the saw blade and right vise jaw, set the angle of the right jaw to the required angle.
3. Tighten the pivot and lock bolts.

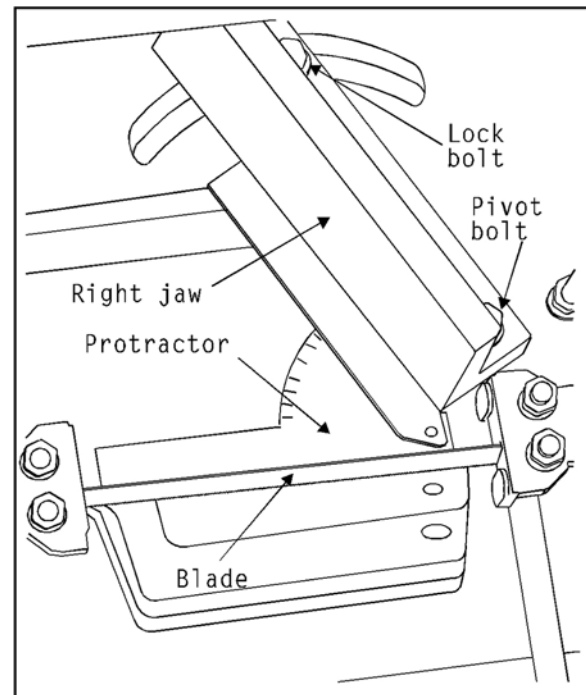

Figure 9: Using a protractor to set the vise jaws at desired angle. By setting the protractor to 90 degrees, or using a machinist's square, the jaws can also be set square with respect to the blade.

1. Lift the saw arm to its full up position and lock it up using the hydraulic feed control knob.
NOTE: Use the handle on the arm to lift the arm. Never use any other part of the arm as a lifting method.
2. Loosen the left jaw lock bolt.

- Use the handwheel to move the left jaw until it touches the right jaw firmly.
- Snug the left jaw lock bolt. Both vise jaws are now the correct angle for the required cut.

NOTE: There is a scale on the back of the saw table which allows you to set up for angle cuts without using a protractor. See *Figure 10*. These angles should be considered approximate, and the protractor method should be used where higher accuracy is required.

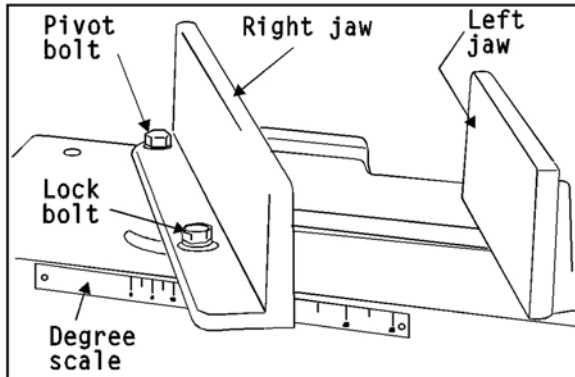

Figure 10: Using the scale on the rear of the saw base to set the jaws for angle sawing. Where the edge of the right jaw crosses the scale an approximate angle cut can be made to the indicated number of degrees on the scale.

8.4 Clamping methods

The method for clamping different cross-section work pieces is shown in *Figure 11*.

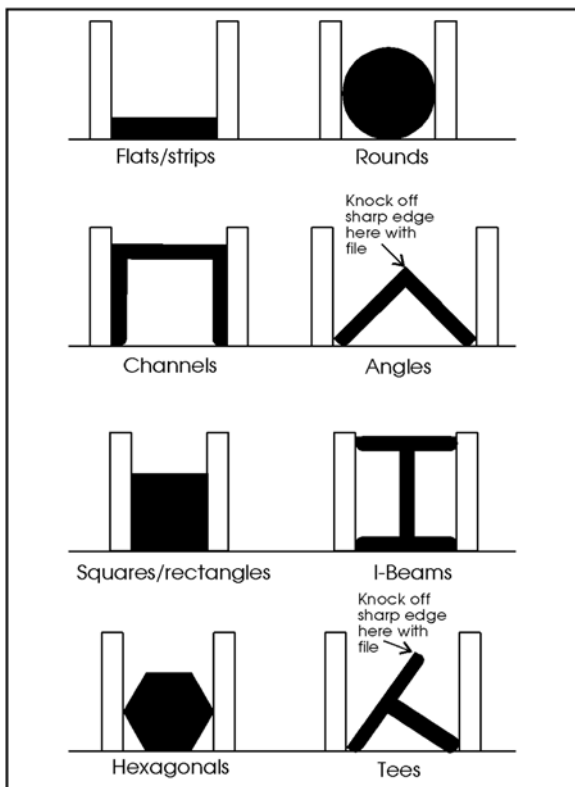

Figure 11: Clamping methods for various cross-sections of stock

8.5 Using the stock stop

When cutting a number of identical pieces, the use of the stock stop can speed operations.

Refer to *Figures 1 and 12*.

- Disconnect the saw from its electric power source.
- With the arm in its fully lowered position, loosen the stock stop set screw.
- Slide the stock stop to the required distance from the blade.
- Rotate the stock stop so the stop is at the lowest possible position for stopping the work piece at the required distance. This will help prevent any binding between the work piece and blade when the cut is completed.
- Tighten the stock stop set screw securely.
- For best accuracy, make a test cut on a piece of scrap material to verify the length of cut using the stock stop.

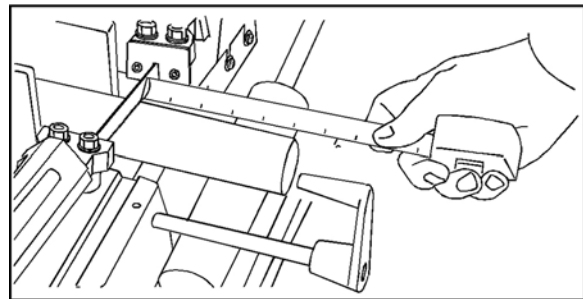

Figure 12: Setting the stock stop cutoff length

8.6 Blade selection

The saw is delivered with a blade adequate for a variety of jobs on a variety of common materials. However, JET's blades, while appropriate to many shop cutting needs, don't begin to exhaust the wide variety of special blades available for special cutting jobs.

For high production cutting of special materials, or for hard-to-cut materials such as stainless steel, tool steel, titanium, etc., ask your industrial distributor for more specific blade recommendations.

Material	Speed
Steel shapes and low carbon steel	125
Medium and high carbon steel	85
Cr-Moly steel	125
Chromium steel	125
Tool steel	85
Cast iron	85
Aluminum	85-125
Most plastics	200
Wood	200

Table 2: Recommended blade speeds

8.7 Changing blade speeds

1. Refer to *Table 2* for recommendations on blade speed for various materials.

Note: These are approximate speeds. Different alloys and section materials and the use of cutting fluid may require other speeds. Check your machinists' handbook, or ask for recommendations from your blade, cutting fluid or workpiece suppliers for specific recommendations on specific material.

2. Disconnect the saw from its electrical power source.
3. With the arm in its fully lowered position, remove the pulley cover lock screw and open the pulley cover. Refer to *Figure 13* for speeds and belt positions.

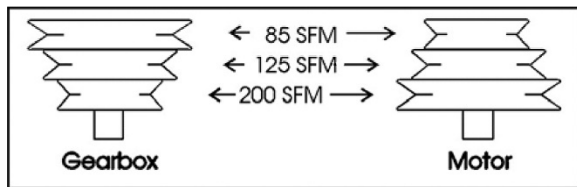

Figure 13: Blade speeds and belt positions

4. To change the belt position (and, therefore, the blade speed) first loosen the motor plate adjustment lock nut. Refer to *Figure 14* for the position of the motor plate adjustment screw and locknut.

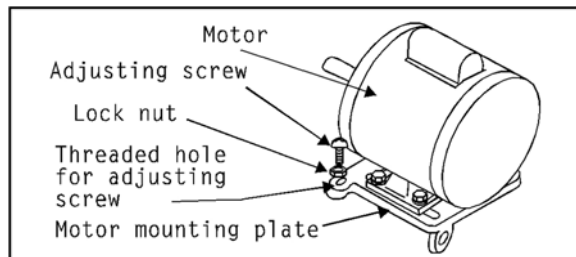

Figure 14: Motor plate adjustment screw

5. Turn the adjustment screw counterclockwise until the belt can be moved to the pulley position required.
6. Turn the adjustment screw clockwise to tension the belt until there is 1/2 inch of play in the belt as shown in *Figure 15*.

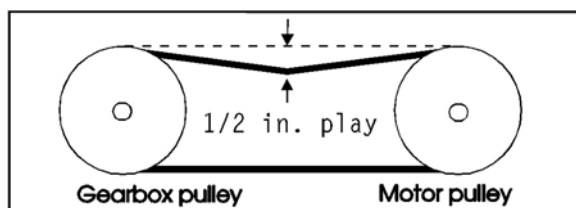

Figure 15: Setting correct play in drive belt

7. Tighten the adjustment lock nut.
8. Close the pulley cover and secure it shut with the lock screw.

5. Re-establish electrical power to the saw and proceed with cutting.

8.8 Evaluating cutting efficiency

Is the blade cutting efficiently? The best way to tell is by observing the chips formed by the blade as it cuts.

If the chip formation is powdery, then the feed is much too light or the blade is too dull.

If the chips formed are curled, but straw or blue colored, then the feed rate is too high.

If the chips formed are curled but not colored, then the blade is sharp enough and cutting at an efficient rate.

8.9 Cutting procedure

1. Never start a cut with the blade resting on the work piece.
2. Be certain you knock off the sharp corners of any work piece material which might damage the blade. See *Figure 11*.
3. Have the motor ON and running at full speed before lowering the blade into the cut.
4. Use the hydraulic control valve to feed the blade into the work piece.
5. If you use a cutting fluid, turn the valve on before beginning the cut.

8.10 Using the hydraulic feed control

Refer to *Figure 16*.

The hydraulic feed control cylinder is a "single action" hydraulic cylinder. This allows you to lift the arm at any time, easily, but controls the downward movement of the arm using a valve on the top of the cylinder.

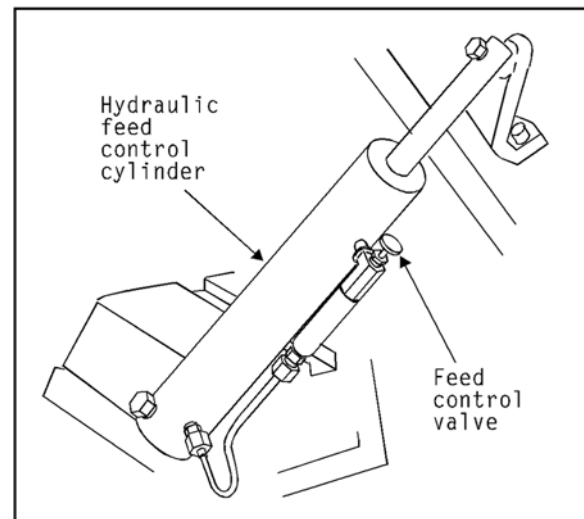

Figure 16: Hydraulic feed control

When the control valve is turned fully clockwise the cylinder is "locked" and the saw arm will not move downward. You can lock the arm, using the valve, at any position in its travel. This allows you to lock the arm in its up position for operations which require it. And it allows you to lock the arm in positions which allow you to adjust work piece length, etc.

Most important, use of the valve allows you to begin any cuts "gently," which can greatly extend the life of the blade. Simply open the valve slightly to begin the cut, then open the valve to effective cutting feed. See *Evaluating cutting efficiency*.

The valve is also important when breaking in any new blades. See Blade break-in procedures.

8.11 Blade break-in procedures

New blades are very sharp, and therefore have a tooth geometry which is easily damaged if a careful break-in procedure is not followed. You may want to consult manufacturers' literature for break-in of specific blades on specific materials. However, the following break-in procedure will be adequate for break-in of JET supplied blades.

1. Clamp a 2 inch or larger work piece in the saw.
2. Set the blade speed to its required speed. See *Changing blade speeds*.
3. If possible, use a cutting fluid during break-in cuts.
4. Set the hydraulic control valve just enough to begin a *very light cut* on the work piece.
5. When the blade has cut 1/3rd of the way through the work piece, increase the feed rate *slightly* and allow the blade to complete the cut.
6. Make another cut on the stock. Begin the cut with the control valve set at the same feed rate you finished the first cut.
7. 1/3rd of the way through the second cut, increase the rate of feed until the blade is cutting at its most efficient rate. See *Evaluating cutting efficiency*.
8. Allow the saw to complete this second cut. The blade can now be considered ready for regular service.

Note: There are flanges on the back face of the drive and idler wheels to prevent the blade from "walking off" the back of the wheels. If these flanges are damaged the wheels must be replaced. Check blade tracking whenever changing a blade to be certain the blade is positioned correctly on the wheels. See *Blade tracking* in the *Maintenance* section of this manual

8.12 Changing blades

1. Disconnect the saw from its electric power source.

2. Lift the saw arm to its full up position and lock it up using the hydraulic feed control knob.

NOTE: Use the handle on the arm to lift the arm. Never use any other part of the arm as a lifting method.

3. Remove the blade guard cover thumb screw and open the cover.
4. Loosen the blade tension knob until the blade comes off of its wheels.
5. Using leather gloves to protect from cuts, slip the blade out of the blade guide bearings and off of the saw.
6. Examine the drive and idler wheels for evidence of wear on the flanges. If the flanges are wearing, the blade is misadjusted. See *Blade tracking* for correcting this condition.
7. Put a replacement blade in the blade guide bearings and loop the ends of the blade over the drive and idler wheels.

NOTE: The saw blade teeth must point in the direction of travel. See *Figure 17*.

8. Use the blade tension knob to put tension on the blade until it no longer slips on the wheels.

NOTE: Do not overtighten the blade. Just increase tension until the blade does not slip on the wheels.

9. Close the blade guard cover and replace and tighten the thumb screw.
10. Reconnect the saw to its electrical power source.

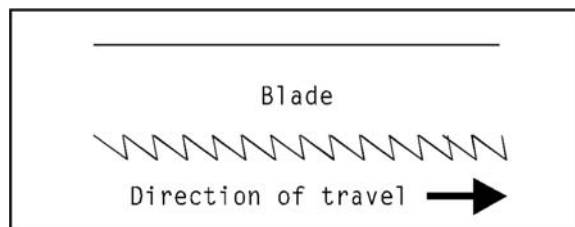

Figure 17: Correct tooth direction when replacing blade.

8.13 Adjusting blade guides

Refer to *Figure 1*.

Both the left and right blade guides should be positioned as close as possible to the left and right edges of any work piece being cut. This provides support to the blade so it can make a straight cut.

1. Loosen the blade guide knobs.
2. Slide the blade guides to the correct spacing.
3. Tighten the lock knobs securely.

9.0 Maintenance

NOTE: The following maintenance operation requires the services of a licensed electrician.

9.1 Motor replacement

1. Perform steps 2 through 5 in *Changing blade speeds*, sect. 9.7.
2. Remove the drive belt.
3. Remove the set screw which retains the motor drive pulley to the motor shaft.
4. Pull the pulley off of the motor drive shaft.
5. BEING CERTAIN THAT THE SAW HAS BEEN SAFELY DISCONNECTED FROM THE SERVICE BRANCH, open the motor terminal cover and remove the three wires which connect it to the power cable.
6. Remove the four nuts, bolts and washers which hold the motor to its mounting plate.
7. Remove the motor from the saw.
8. Reinstall the replacement motor and pulley by reversing steps 7 through 4, above.
9. Loosen the motor mounting plate adjustment screw so the screw puts no tension on the plate.
10. Adjust the position of the motor so that:
 - A. the pulleys are parallel with each other, and
 - B. the drive belt can just be installed over the pulleys (It may be necessary to adjust the drive pulley along the motor shaft to make the pulleys parallel.)
11. Tighten the motor mounting bolts securely.
12. Tighten the pulley set screw securely.
13. Install the drive belt.
14. Tension the drive belt and complete the replacement task by performing instructions 5 through 9 in *Changing blade speeds*.

9.2 Adjusting guide bearings

The outside guide bearing on each of the bearing seats is mounted on an eccentric shaft to allow adjustment of the bearing clearance between bearings and blade, as follows:

1. Loosen the guide bearing shaft lock nut.
2. Use an open end wrench on the hex flats underneath the guide seat to adjust the eccentric shaft so the bearing holds the blade vertically against its opposing bearing. Over-tightening the blade between the bearings will only shorten bearing life. Adjust the bearings so blade is just held firmly in vertical position.

3. While holding the shaft from turning, tighten the lock nut on the upper side of the bearing seat.

9.3 Blade tracking

1. If the blade is fully tensioned, release tension slightly while performing the tracking operation.
2. If the blade is not on slow speed, change to the slowest speed according to instructions in *Changing blade speeds*.
3. Lift the saw arm to its full up position and lock it using the hydraulic feed control knob.

NOTE: Use the handle on the arm to lift the arm. Never use any other part of the arm as a lifting method.

4. Remove the thumb screw and open the blade guard cover. Prop it open so you can have access to the idler wheel.
5. Refer to *Figure 18*. Use a wrench to loosen bolt **A**, a small amount.

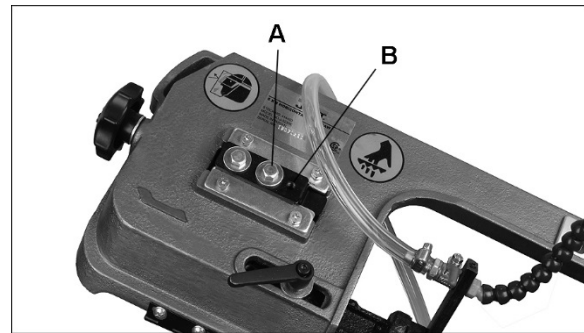

Figure 18: Blade tracking mechanism

6. Turn the saw motor ON.
7. Insert a hex wrench into the set screw, **B**, and turn it slightly while observing the tracking action of the blade on the idler wheel. Turning the hex wrench clockwise will make the blade track toward the wheel flange. Turning the wrench counterclockwise will make the blade track away from the flange.
8. Adjust the set screw in *very small amounts* until the blade just starts to track toward the flange.
9. As you adjust the blade toward the flange, insert a strip of paper between the blade and wheel as shown in *Figure 19*.

⚠ WARNING Use a strip of paper six inches long or longer so your hands stay clear of the moving parts of the saw.

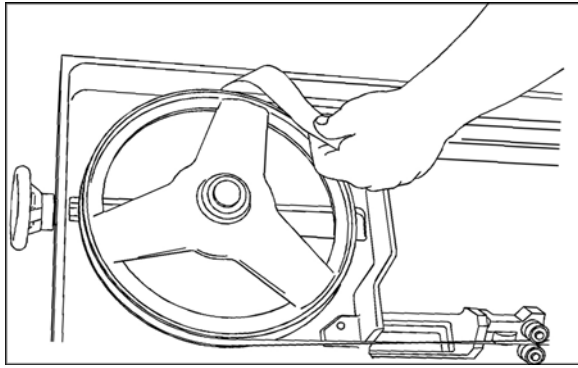

Figure 19: Checking blade tracking

10. Keep using *small amounts* of adjustment to move the blade toward the flange, testing with the paper strips, until the paper is cut between the blade and flange.
11. When the paper is cut, turn the hex wrench *slightly* in the opposite direction so the blade does not track while touching the flange.
12. Tighten bolt **A**.
13. Check with a paper strip to be certain the blade has not moved back into contact with the flange. Readjust, if necessary.
14. Using the blade tension knob, reapply tension to the blade so it does not slip on the wheels.
15. Turn the saw OFF.
16. Close the blade guard cover and install and tighten the thumb screw.

9.4 Replacing guide bearings

1. Remove the blade according to instructions 1 through 5 in *Changing blades, sect. 9.12*.
2. Remove the snap ring which holds the bearing to the shaft.
3. Press off the bearing.
4. Press on the new bearing and secure it with the snap ring.
5. Reinstall the blade according to instructions 6 through 10 in *Changing blades*.
6. Adjust the bearing spacing according to instructions in *Adjusting guide bearings*.

9.5 Adjusting back-up bearings

Refer to Figure 20.

1. Disconnect the saw from its electrical power source.
2. Loosen the guide bearing seat retaining bolt.
3. Slide the bearing seat as necessary until the back-up bearing just touches the back edge of the saw blade.
4. Tighten the guide bearing seat retaining bolt.
5. Restore electrical power to the saw.

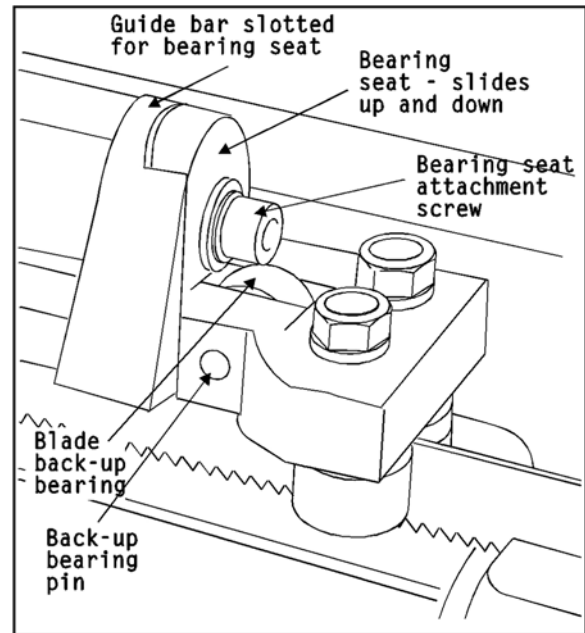

Figure 20: Adjusting back-up bearings

9.6 Adjusting the arm stop adjustment bolt

Refer to Figure 1.

1. Lower the arm to its fully lowered position. The saw blade should be level and the cutting edge of the blade should be in the relief slot, *below* the level surface of the saw base. If this is not the case, adjust the arm height as follows:
2. Loosen the leveling bolt lock nut.
3. Adjust the leveling bolt until it supports the arm and blade correctly as described above -- level and below the top of the saw base.
4. Tighten the leveling bolt lock nut.

9.7 Adjusting motor switch actuator

This task should be performed whenever the arm stop adjustment is corrected or whenever the saw is turning off incorrectly.

Refer to Figure 1.

1. Raise the arm until the switch actuator is not in contact with the switch.
2. Turn the switch ON.
3. Open the hydraulic control valve so the arm moves slowly downward.
4. The motor switch should shut off just as the arm contacts its horizontal stop bolt and the blade is fully below the blade relief in the saw base. If the motor shuts off too soon, or not at all, adjust the switch actuator by bending it, as required, to correct the fault condition.

9.8 Replacing a back up bearing

1. Remove the blade according to instructions 1 through 5 in *sect. 9.12*.
2. Remove the guide bearing assembly from the saw arm by removing the guide lock knob and sliding the assembly from the arm.
3. Use a drift to knock out the pin until the bearing can be removed.
4. Replace the bearing and press the shaft back into the seat.
5. Reinstall the bearing assembly in the arm.
6. Reinstall the blade according to instructions 6 through 9 in *sect. 9.12*.
7. Adjust the back-up bearing spacing according to instructions in *Adjusting back up bearings*.

9.9 Adjusting the bearing guide seats for blade vertical

1. Install a new blade according to instructions in *sect. 9.12*.
2. Adjust the guide bearings according to instructions in *sect. 10.2, Adjusting guide bearings*.
3. Adjust the back-up bearing according to instructions in *sect. 10.5, Adjusting back-up bearings*.
4. With the arm in its full horizontal position and the blade guides moved apart to clear the widest possible cutting area, clip a scale to the blade, to provide a vertical reference surface.
5. Place a machinist's square on the saw base, against the scale. See *Figure 21*.

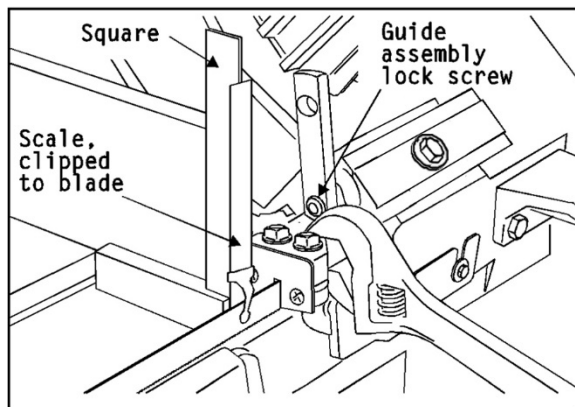

Figure 21: Adjusting the saw blade for vertical. Be sure to do this operation on both of the bearing guide seats so the blade is perfectly vertical along its entire exposed cutting surface.

6. Loosen the guide bearing seat attachment bolt slightly and, using a wrench on the bearing seat, adjust the angle of the seat so the blade is vertical. (There is a small amount of side

relief between the seat and guide bar to allow for this adjustment.)

7. Tighten the seat attachment bolt.
8. Move the scale and square to the other side of the exposed blade and repeat steps 4, 5, 6 and 7, above.

9.10 Test cutting to verify adjustment accuracy

Test cuts can be used to determine whether or not you have adjusted the blade accurately. Use 2 inch bar stock to perform these test cuts, as follows:

1. With the bar stock securely clamped in the vise, make a cut through the bar stock. (See *Figure 22*.)
2. Mark the top of the bar stock.
3. Move the bar stock about 1/4 inch past the blade so you can begin a second cut.
4. Rotate the bar stock 180 degrees so the mark you made is now at the bottom of the cut.
5. Make a cut through the bar stock.
6. Use a micrometer to measure the thickness variation between the top and bottom of the disc you have cut from the bar stock. Unless things are truly perfectly aligned, there is almost certain to be a certain amount of "wedge" to the shape of the disc you have cut. The saw blade can be considered correctly adjusted when the variation measured is no more than .012 inch across the face of the disc. If you do not have a 2 inch bar stock available for a test cut, use a larger diameter test work piece rather than a smaller one. The maximum thickness variation on any test piece should be no more than .003 inches, per side, per inch of stock diameter.

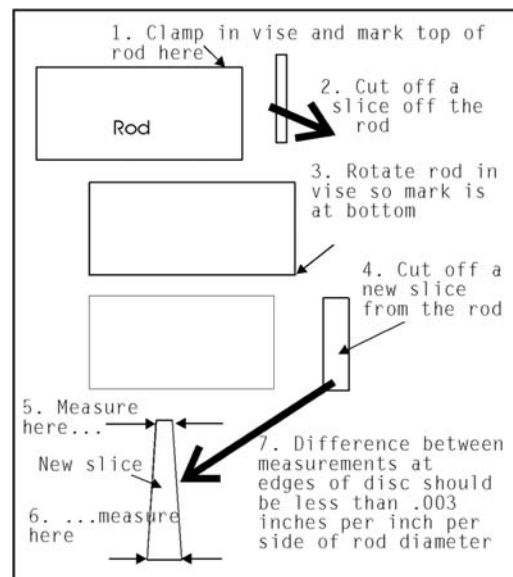

Figure 22: Making a test disc.

10.0 Maintenance Chart

Item	Action	Interval	Comments
Wheel, guide or back-up bearings	Inspect for leakage	Daily	All bearings are sealed – any leaking bearing must be replaced.
Lead screw	Wipe on lubricant	Weekly	Gear oil* (see note, below)
Drive belt	Inspect and replace when glazed or worn	When changing blade speeds	
Gearbox	Inspect for leakage – repair if leaking	Daily	
	Replace lubricant	Annually	Gear oil*(see note, below)
Drive and idler wheels	Inspect flange and blade surfaces	When changing blades	Replace wheels if flanges are worn
Hydraulic cylinder assembly	Clean control rod with a clean rag	Daily	Dirt on the control rod can damage the seal and cause leakage -- resulting in replacement of the cylinder assembly.

Table 3

* Note: Gearbox and lead screw lubrication: Lubricate the vise lead screw and gearbox with Shell Omala S1W or its equivalent.

The gearbox gears run in an oil bath and will not require lubricant change more than once a year unless the lubricant is accidentally contaminated or leakage occurs due to improper replacement of the gearbox cover or gasket. During the first few days of operation the drive gears will run hot. Unless the temperature exceeds 200 degrees F., there is no cause for concern.

11.0 Troubleshooting the J-3130 and J-3230

Table 4

Symptom	Possible Cause	Correction
Excessive blade breakage.	Material loose in the vise.	Use more pressure to tighten vise.
		Check right jaw pivot and lock bolts for tightness.
		Check left jaw pivot bolt for looseness -- be certain the jaw is not tilting upward when you apply pressure to the work in the vise.
		If you are stacking multiple pieces in the vise, be sure all of the pieces are captured by the vise pressure.
	Incorrect feed or speed.	Check technical literature for recommended feeds and speeds for the material and blade you are using.
		Check chip formation to adjust speed and feed to correct rate when sawing.
	Incorrect blade tension.	Adjust blade tension to where it just does not slip on the wheel.
	Teeth in contact with work before saw is started.	Be sure the saw motor has come fully up to speed before beginning a cut and be sure the blade is not resting on the work piece before the motor has come up to full speed.
	Blade rubs on wheel flange.	Use paper cutting method of adjusting blade tracking. See <i>Blade Tracking</i> .
Check drive and idler wheels for looseness in mounting parts or worn/damaged bearings.		
Misadjusted blade guides.	Adjust blade guides.	
Blade too thick for wheel diameter	Use a thinner blade. Check with your blade supplier for recommendations on blade thickness for a specific wheel diameter.	
Cracking at weld	Replace blade.	
Premature blade dulling.	Teeth too coarse.	Use finer tooth blade.
	Blade speed too high.	Try next lower speed or check technical literature for specific recommendations regarding speeds for specific blade and material being cut.
		Check with materials supplier for recommendations on the work piece material supplied.
		If using coolant, check with supplier regarding correct coolant for the job.
	Inadequate feed pressure.	Increase pressure while observing chip formation to be sure you are cutting efficiently.
	Hard spot or scale on material.	Reduce speed of blade.
		Increase feed pressure in scale or hard spots.
	Work hardening of material (especially stainless steel).	Work hardening materials such as stainless require a heavy, continuous cut. Be sure you are using a sharp blade, then, if necessary, release some counterbalance spring pressure by loosening the tension nut if work hardening of the material is a problem.
Blade installed backwards.	Reinstall blade so teeth point toward right end of saw.	

Symptom	Possible Cause	Correction
Premature blade dulling. (cont.)	Incorrect coolant or no coolant.	Check with materials supplier and/or blade supplier for coolant recommendations. Check with coolant supplier for specific recommendations on the blade and material you are using.
	Insufficient blade tension.	Increase tension so blade is above the slipping point.
Crooked cuts.	Work not square.	Adjust the right vise jaw so it is at right angles to the blade.
		Clamp work tightly in the vise.
		Check blade for vertical and adjust, if necessary.
		Move guide bearings as close as possible to work while still completing the cut.
		Check guide bearings, seats and brackets for possible looseness or wear.
	Feed pressure too great.	Observe chip formation to be sure cutting is efficient.
	Guide bearings not adjusted properly.	Adjust guide bearings according to instructions in this manual.
	Inadequate blade tension.	Increase blade tension so blade does not slip on the wheels.
	Blade guides incorrectly spaced.	Move guide brackets until they just clear the work piece while making a complete cut.
		For small section pieces, be sure the blade is sharp and correctly tensioned. Use less feed pressure.
	Dull blade.	Replace blade when it dulls.
		Consider using a coolant, if not already used.
	Incorrect speed.	Check technical literature for recommended speeds and blade type for material being cut – observe chip formation to verify efficient cutting.
	Blade guide assembly loose.	Tighten guide bracket.
	Blade guide bearing assembly loose.	Check tightness of bearing seat bolt.
Blade tracking too far away from wheel flanges.	Use paper cutting method of setting blade tracking.	
Worn upper wheel bearings.	Replace bearings if worn.	
Loose upper wheel mounting assembly.	Tighten all bolts securing wheel to arm.	
Rough cuts.	Too much feed or speed.	Try one step lower speed and observe chip formation for efficient cutting/feed rate.
	Blade too coarse.	Use finer blade. Check with suppliers for recommendations for the material you are cutting.
	Incorrect blade for material.	Check with blade suppliers for recommendations for exotic or unusual materials or specifications.
Blade twisting.	Cut is binding blade.	Be sure work piece is flat on saw base.
		Decrease feed pressure.
	Too much blade tension.	Reduce tension to just above point where blade slips.
	Loose guide bearing eccentrics.	Check eccentric jam nuts for tightness.
Worn guide bearings.	Check guide bearings for wear. Replace if necessary.	

Symptom	Possible Cause	Correction
Blade twisting. <i>(cont.)</i>	Incorrect guide bearing adjustment	Adjust guide bearings according to instructions in this manual.
	Loose guide bearing bracket	Tighten bracket on saw arm.
	Loose bearing seat attachment screw	Tighten bearing seat attachment screw – adjust bearing clearance.
Unusual wear on side/back of blade.	Blade guides worn.	Replace.
	Blade guide bearings not adjusted properly.	Check and adjust for proper clearance.
	Blade guide bearing bracket loose.	Tighten bracket to saw arm.
	Blade running on wheel flange.	Adjust blade tracking using the paper cutting method.
Breaking teeth.	Teeth too coarse for work.	Use blade with finer pitch.
	Too heavy feed.	Decrease feed rate – observe chip formation to verify efficient cutting.
	Too slow speed.	Increase blade speed. Check technical literature or blade or work piece supplier for blade speed recommendations.
	Vibrating work piece.	Be sure vise is tight.
		Support slender cross section or long work pieces with appropriate in feed and out feed supports.
		If stacking pieces in the vise, be sure all work pieces are securely captured by the vise.
	Tooth gullets loading	Use coarser blade or one with a tooth geometry more appropriate to the work piece being cut.
Blade in contact with work piece before motor is started.	Always allow motor to come fully up to speed before beginning cut.	
Motor running too hot.	Blade tension too high.	Decrease blade tension to just above slip point.
	Worn transmission and worm gear.	Replace gears in transmission gearbox.
	Gears need lubrication.	Check gearbox and add oil as required.

12.0 Replacement Parts

Replacement parts are listed on the following pages. To order parts or reach our service department, call 1-800-274-6848 Monday through Friday, 8:00 a.m. to 5:00 p.m. CST. Having the Model Number and Serial Number of your machine available when you call will allow us to serve you quickly and accurately.

12.1.1 J-3130/3230 Lower Saw Head – Exploded View

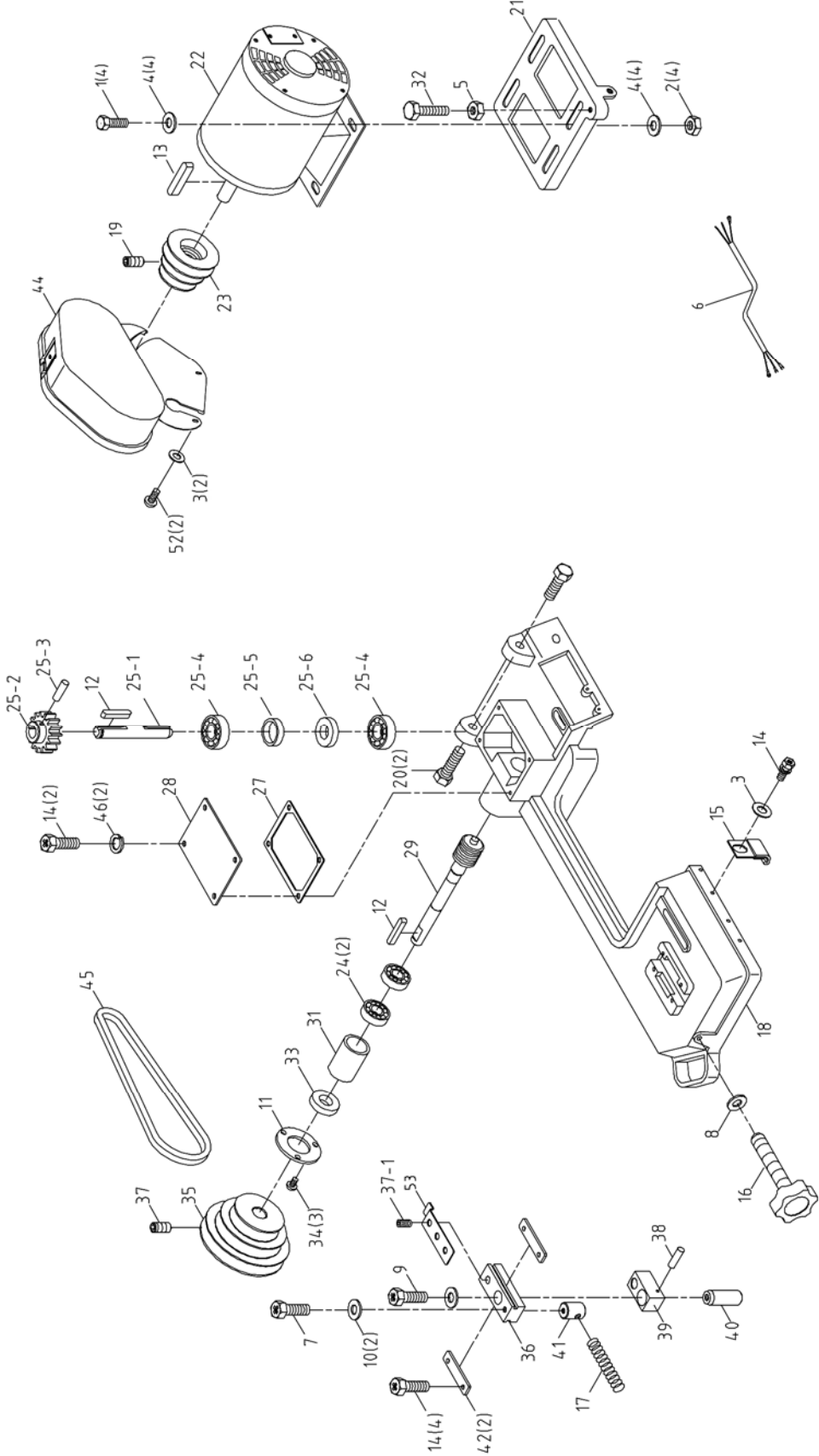

12.1.2 J-3130/3230 Lower Saw Head – Parts List

Index No	Part No	Description	Size	Qty
01	5631421	Hex head Screw	1/4"-20x3/4"	4
02	5631431	Hex nut	1/4"-20	4
03	5630221	Washer *	1/4"x5/8xt1.5mm	3
04	5631451	Washer	5/16"x23xt2	8
05	5630061	Hex nut	5/16"-18	1
06	5631161	Motor cable		1
07	5630471	Hex head screw	5/16"-18x1-1/4"L	1
08	5630301	Washer	3/8"x27xt3	1
09	5631481	HH screw	5/16"-18x3/4"L	2
10	5630461	Washer	5/16"x23xt3	2
11	5630661	Wheel bearing Cover		1
12	5630671	Key	5x5x25mm	2
13	5632011	Motor key	5x5x30mm	1
14	5632021	Hex head screw	1/4"-20x1/2"L	9
15	5630701	Switch activator bracket		1
16	5630731	Blade tension adjustment knob	3/8"-16UNCx94mmL	1
17	5630741	Spring		1
18	J-5630751G	Head casting		1
19	5630681	Set screw	M8-P1.25x8L	1
20	563077A	Hex head screw	3/8"-16x1-1/4"L	2
21	563078AG	Motor mounting plate		1
22	J-5630791	Motor	1/2HP, 1PH, 115V	1
23	5630811	Motor pulley		1
24	5630821	Ball bearing	6202Z	2
25	5633121	Transmission gear shaft		1
25-1	5521940	Transmission Wheel Shaft		1
25-2	5521941	Transmission Gear		1
25-3	5521942	Pin	4x22mmL	1
25-4	5630821	Ball Bearing	6202ZZ	2
25-5	5521943	Bushing		1
25-6	5630941	Oil Seal	TC15x35x7	1
27	5630871	Gearbox gasket		1
28	5630881G	Gearbox cover		1
29	5630921	Worm gear & shaft assy.		1
31	5630911	Bearing bushing		1
32	563093A	Belt tension adj. screw	5/16"-18x1-1/2"L	1
33	5630941	Oil Seal	TC15x35x7	1
34	5632031	RH Phillips screw	5/32"-32x3/8"L	3
35	5630961	Worm gear pulley		1
36	5630971	Blade tension guide block		1
37	5630981	Set Screw	M8-P1.25x15mmL	1
38	5630991	Spiral pin	4x20L	1
39	5631001	Sliding plate draw block		1
40	5631011	Blade wheel shaft		1
41	5631021	Tension block		1
42	5631031	Guide block holder		2
43	5631041	Guard plate		1
44	5631051	Pulley guard		1
45	5631061	V-Belt	4L230	1
46	5631151	Lock washer	1/4"	1
47	5631311	Vent plug		1
48	5632081	Rubber plug		1
49	5521944	Cylinder Upper Bracket		1
50	TS-2248162	Socket HD button screw	M8X16	2
50	5521951	Hex head screw	5/16"-18x7/8"L	2
51	TS-1550061	Flat Washer	M8	2
51	5521952	Lock Washer	5/16"	2
52	5632021	Hex head screw *	1/4"-20x1/2"L	2
53	5521945	Tension guard		1
	JET-92	JET Logo with 3M Adhesive (not shown)		1

* indicates items included in J-3130G-HK Hardware Kit

12.2.1 J-3130/3230 Upper Saw Head – Exploded View

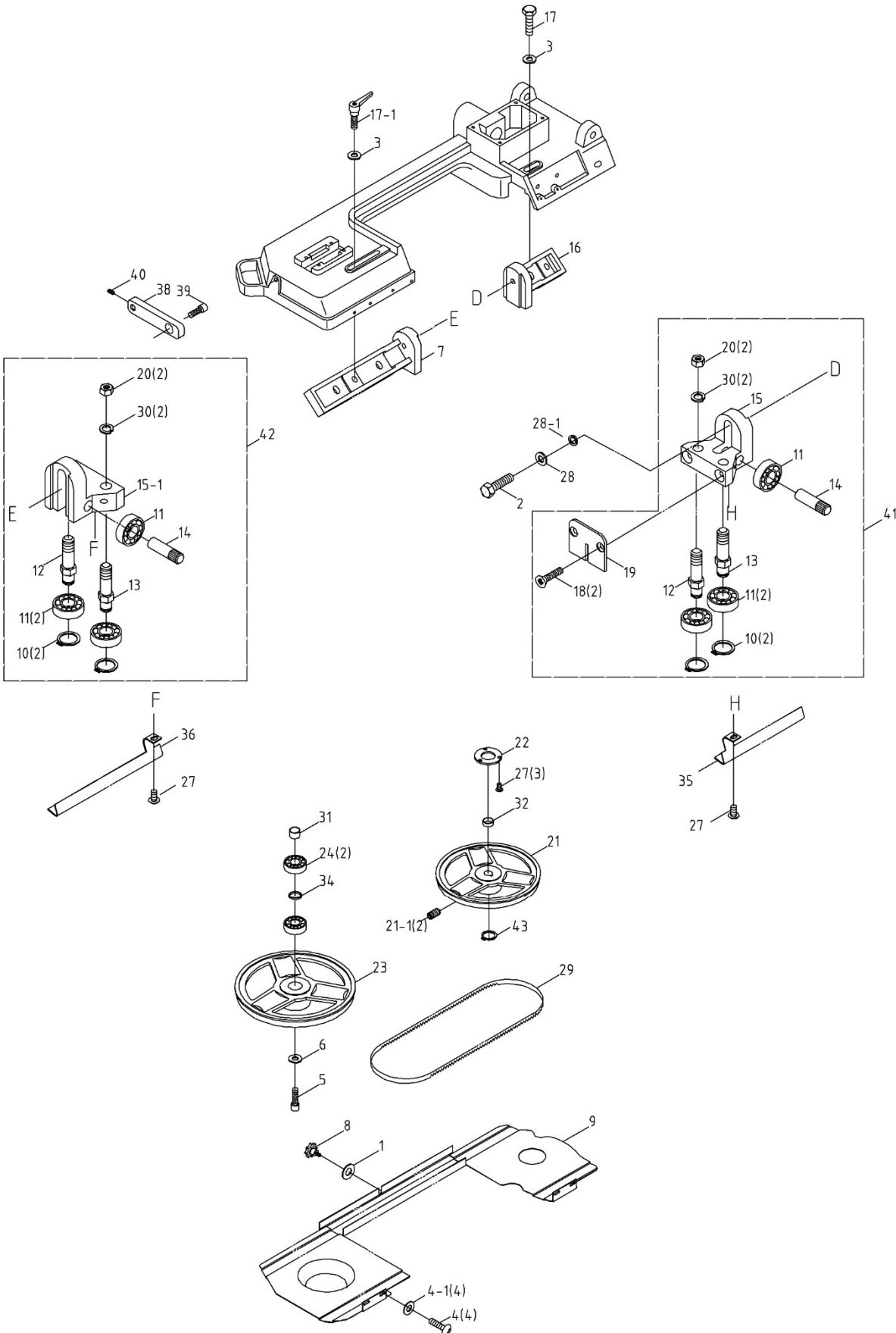

12.2.2 J-3130/3230 Upper Saw Head – Parts List

Index No	Part No	Description	Size	Qty
01	5630221	Washer	1/4"x16xt1.5	1
02	5630051	Hex head screw	5/16"-18x1-1/4"L	2
03	5630301	Washer	3/8"x27xt3	3
04	5631471	RH Phillips screw	3/16"-24x3/8"L	4
05	5631481	Hex head screw	5/16"-18x3/4"L	3
06	5630461	Washer	5/16"x23xt3	1
07	5630511A	Top guide bar		1
08	5630521	Knob		1
09	J-5630531	Blade guard cover		1
10	5630541	Retaining ring	5/16"x0.040	4
11	563055A	Bearing	608 and 629	6
12	563056A	Straight shaft		2
13	563050A	Eccentric shaft		2
14	563057A	Bearing pin shaft		2
15	563129A	Bearing bracket, right		1
15-1	5521954	Bearing bracket, left		1
16	563059A	Bottom guide bar		1
17	TS-0060061	Hex cap screw	3/8"-16x1-1/4"L	1
17-1	J3130-17-1	Lock handle		1
18	5630621	Flat head screw	1/4"-x20x1/2"L	1
19	5630631	Deflector plate		1
20	5630641	Hex Nut	3/8-16UNC	4
21	5630651	Drive wheel		1
21-1	TS-0270021	Socket set screw	5/16"-18x5/16"L	1
22	5630661	Wheel bearing Cover		1
23	5630711	Idler wheel		1
24	5630821	Ball bearing	6202ZZ	2
27	5632031	RH Phillips screw	5/32"-32x1/4"L	5
28	5632041	Washer	5/16"x2mm	1
28-1	TS-0720081	Lock washer	5/16"	1
29	5631241	Standard blade	14Tx1/2x.025x68	1
	5631261	Optional blade	8Tx1/2x.025x68	1
	5631071	Optional blade	10Tx1/2x.025x68	1
30	5631081	Split lock washer	3/8"	4
31	5631121	Bushing		1
32	5632051	Drive wheel bushing		1
33	5631341	Retainer ring		1
34	5630721	Bushing		1
35	J-563120A	Bottom blade guard		1
36	J-5631211	Upper blade guard		1
38	5631231	Bracket		1
39	5630261	Aluminum hd. screw	5/16"-18x1-1/4"L	1
40	5632131	Set screw	1/4"-20x3/8"L	1
41	5631371	Bottom blade guide assembly		1
42	5631361	Top blade guide assembly		1
43	5518413	C-Ring	S15	1

12.3.1 J-3130/3230 Saw Base – Exploded View

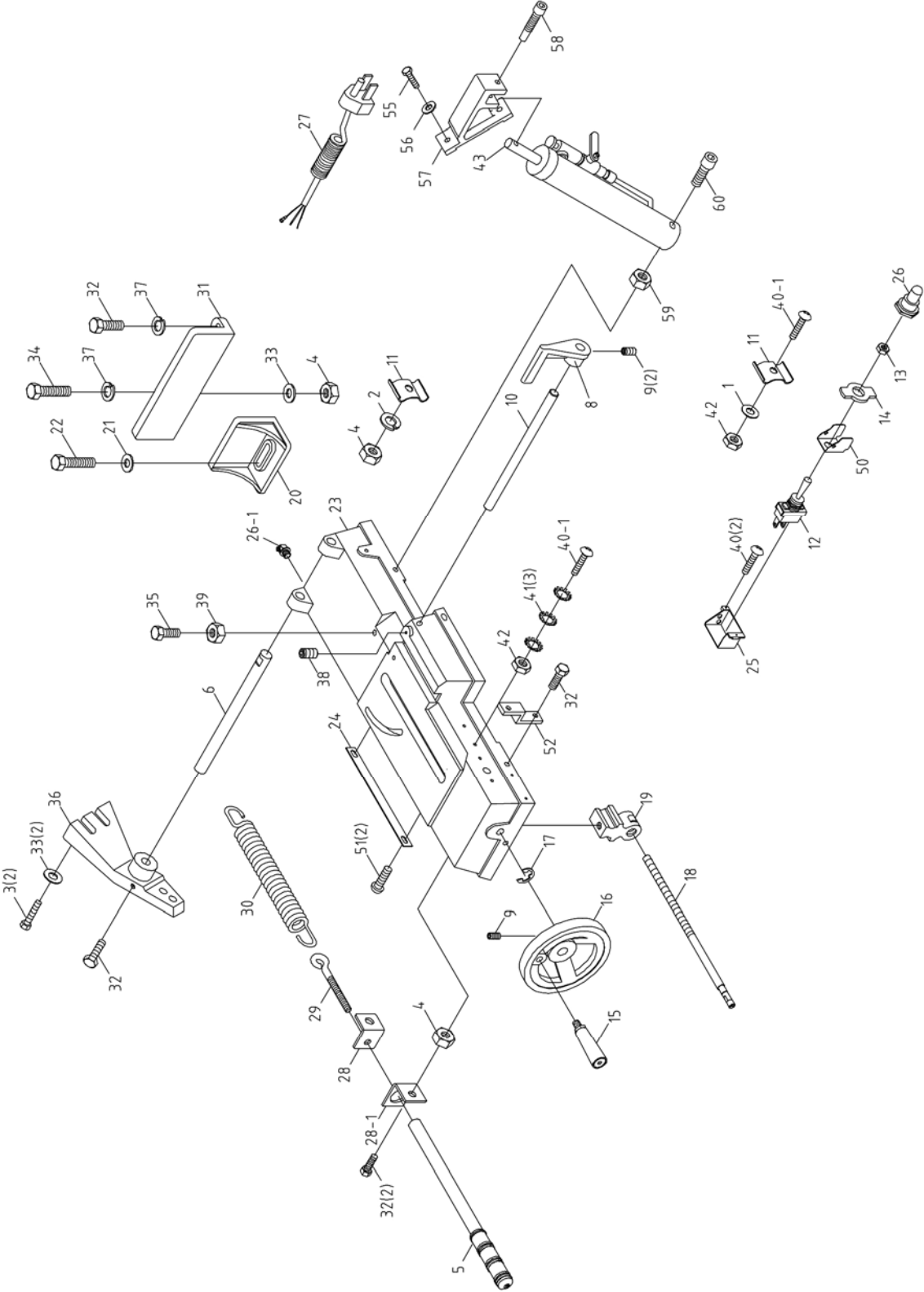

12.3.2 J-3130/3230 Saw Base – Parts List

Index No	Part No	Description	Size	Qty
01	5630221	Washer	1/4"x16xt1.5	1
02	5630031	Washer	5/16"	1
03	5630051	Hex head screw	5/16"-18x1"L	2
04	5630061	Hex nut	5/16"-18	8
05	5630081	Adjust rod		1
06	5630111	Pivoting rod		1
07	5630121	Support plate		1
08	5630131	Stock stop		1
09	5630241	Set screw	5/16"-18x5/16"L	2
10	5630151	Stock stop rod	1/2"x216L	1
11	J3130-311	Electric wire restrainer		2
12	5630171	Toggle switch		1
13	5630181	T.S. hex nut		1
14	5630211	ON/OFF plate		1
15	5631091	Handle grip		1
16	5630231	Hand wheel		1
17	5630251	Retaining ring	E10	1
18	5630271	Lead screw		1
19	5630281	Vise nut		1
20	J-5630291	Vise jaw, left		1
21	5630301	Washer	3/8"x27xt3	3
22	5630311	Hex head screw	5/16"-18x1-1/4"L	1
23	J-5630321G	Base casting		1
24	5630341	Scale		1
25	5630351	Switch enclosure		1
26	J3130-326	Plastic Cover		1
26-1	563038A	Wire restrainer	PG9	1
27	5630391	Power supply cable		1
28	5630401	Feed spring bracket, right		1
28-1	5521946	Feed spring bracket, left		1
29	5630411	Eye bolt		1
30	5630421	Spring		1
31	J-5630441	Vise jaw, right		1
32	5631481	Hex head screw	5/16"-18x1"L	6
33	5630461	Washer	5/16"x23xt3	3
34	5630451	Hex head screw	5/16"-18x1-1/2"L	1
35	5631491	Hex head screw	7/16"-14x2"L	1
36	J-5630491G	Pivot		1
37	5630611	Spring Washer	5/16"x3/4"x1/8"	2
38	5630981	Set screw	5/16"-18x5/8"L	1
39	5632061	Hex nut	7/16"-14	1
40	5632091	RH Phillips screw	3/16"-24x3/8"L	2
40-1	5521947	RH Phillips screw	3/16"-24x3/4"L	2
41	5632101	Star Washer	3/16"	3
42	5632111	Hex nut	3/16"-24	1
43	5521948	Cylinder		1
43-1	TS-1540061	Hex Nut, Full	M8	1
50	5521949	Switch Cover		1
52	5521950	Fixed Plate		1
55	TS-0050051	Hex cap screw *	1/4-20x1"	2
56	TS-0680021	Flat washer *	1/4"	2
57	HBS56S-259	Cylinder Upper support * (serial #11110606 and higher)		1
58	TS-0209061	Socket HD cap screw *	3/8"-16x1-1/4"L	1
59	TS-0561021	Hex nut *	5/16"	1
60	J-3130-60	Socket HD cap screw *	5/16"-18x4"L	1
	J-3130-CHK	Cylinder Hardware Kit		

* indicates items included in J-3130-CHK Cylinder Hardware Kit

12.4.1 J-3130/3230 Stand and Coolant System – Exploded View

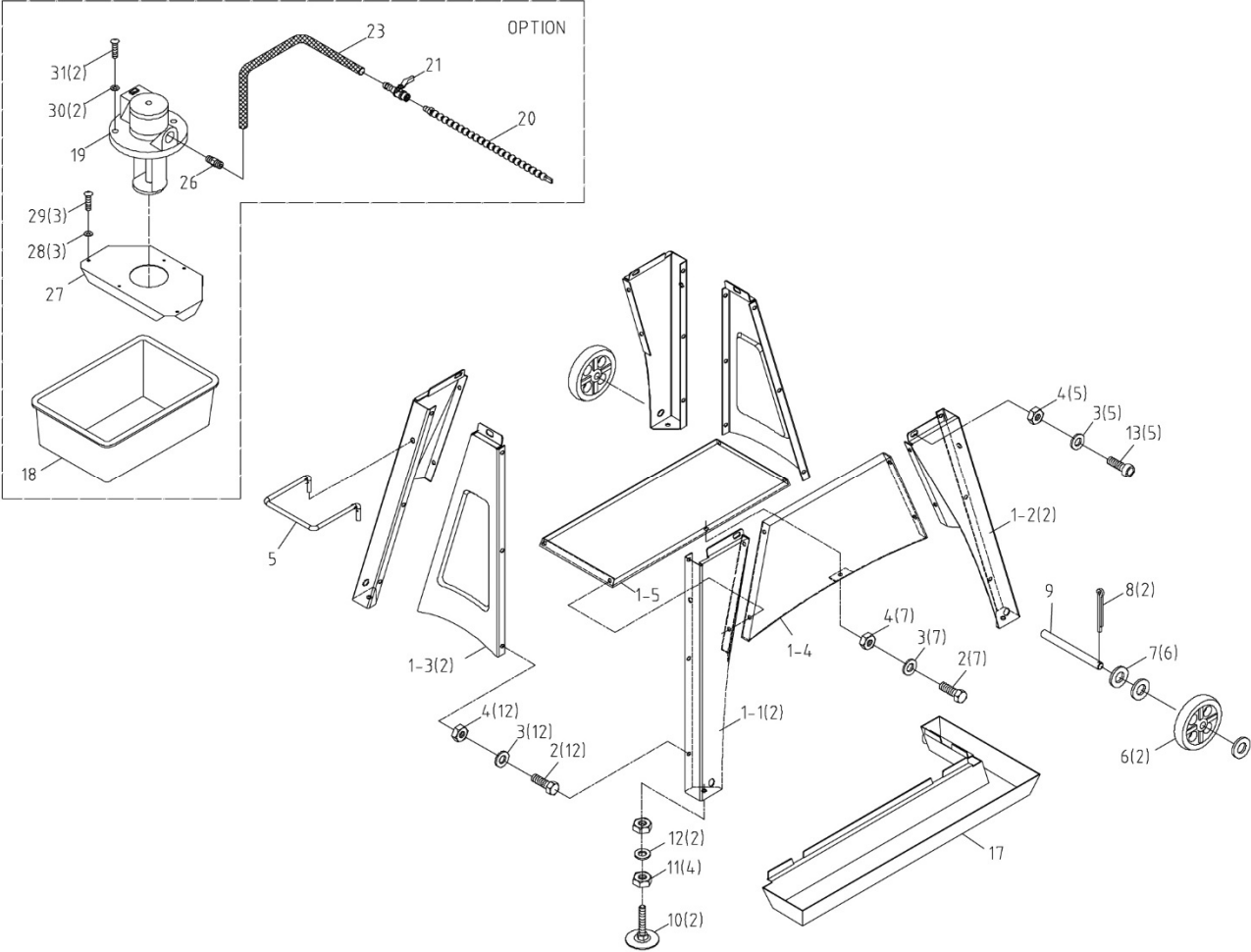

12.4.2 J-3130/3230 Stand and Coolant System – Parts List

Index No	Part No	Description	Size	Qty
1	J-5630041-CSA	Complete Stand Assembly (includes #1 thru 17)		1
1-1	J-5630041-S1G	Left Stand Leg		2
1-2	J-5630041-S2G	Right Stand Leg		2
1-3	J-5630041-S3G	Cross Brace		2
1-4	J-5630041-S4G	Front Panel		1
1-5	J-5630041-S5G	Shelf		1
2	HVBS56M-2	Hex Socket Head Screw w/lock washer *	1/4" x 5/8"	19
3	TS-0680021	Flat Washer *	1/4"	24
4	TS-0570011	Hex Nut *	1/4"	24
5	HVBS462-014	Floor Stand Handle		1
6	5633021-N	Wheel		2
7	TS-0680081	Flat Washer	5/8"	6
8	5631441	Cotter Pin *	1/8" x 1"	2
9	HVBS56M-07	Axle		1
10	HVBS56M-013	Adjustable Foot	3/8"	2
11	TS-0561032	Hex Nut	3/8"UNF	4
12	TS-0680041	Flat Washer	3/8"	2
13	TS-0207071	Socket Head Cap Screw *	1/4 x 1-1/4"	5
17	J-5631171NG	Trough		1
18	J-5042291	Tank		1
19	J-5042281	Coolant pump		1
20	5042341	Nozzle Assembly (includes #24,25)		1
21	5042351	Valve		1
23	9307291	Hose		1
24	5042331	Barb Fitting	1/4" x 1/4"	1
25	5042321	Hose Barb	1/4" x 1/8"	1
26	5042981	Elbow	3/8PT x 5/16"	1
27	3230-0527	Support Plate		1
28	TS-1550031	Washer	M5	3
29	TS-1533042	Screw	M5 x10L	3
30	TS-1551041	Spring Washer	M6	2
31	TS-1534052	Pan Head Screw	M6x15L	2
	5056840	Wet Kit, 115V (includes #18-21,23,26-31)		
	TS-152705	Hex Wrench * (not shown)	4mm	1
	J-3130G-HK	Hardware Kit		

* indicates items included in J-3130G-HK Hardware Kit

13.0 Warranty and Service

JET warrants every product it sells against manufacturers' defects. If one of our tools needs service or repair, please contact Technical Service by calling 1-800-274-6846, 8AM to 5PM CST, Monday through Friday.

Warranty Period

The general warranty lasts for the time period specified in the literature included with your product or on the official JET branded website.

- JET products carry a limited warranty which varies in duration based upon the product. (See chart below)
- Accessories carry a limited warranty of one year from the date of receipt.
- Consumable items are defined as expendable parts or accessories expected to become inoperable within a reasonable amount of use and are covered by a 90 day limited warranty against manufacturer's defects.

Who is Covered

This warranty covers only the initial purchaser of the product from the date of delivery.

What is Covered

This warranty covers any defects in workmanship or materials subject to the limitations stated below. This warranty does not cover failures due directly or indirectly to misuse, abuse, negligence or accidents, normal wear-and-tear, improper repair, alterations or lack of maintenance. JET woodworking machinery is designed to be used with Wood. Use of these machines in the processing of metal, plastics, or other materials outside recommended guidelines may void the warranty. The exceptions are acrylics and other natural items that are made specifically for wood turning.

Warranty Limitations

Woodworking products with a Five Year Warranty that are used for commercial or industrial purposes default to a Two Year Warranty. Please contact Technical Service at 1-800-274-6846 for further clarification.

How to Get Technical Support

Please contact Technical Service by calling 1-800-274-6846. **Please note that you will be asked to provide proof of initial purchase when calling.** If a product requires further inspection, the Technical Service representative will explain and assist with any additional action needed. JET has Authorized Service Centers located throughout the United States. For the name of an Authorized Service Center in your area call 1-800-274-6846 or use the Service Center Locator on the JET website.

More Information

JET is constantly adding new products. For complete, up-to-date product information, check with your local distributor or visit the JET website.

How State Law Applies

This warranty gives you specific legal rights, subject to applicable state law.

Limitations on This Warranty

JET LIMITS ALL IMPLIED WARRANTIES TO THE PERIOD OF THE LIMITED WARRANTY FOR EACH PRODUCT. EXCEPT AS STATED HEREIN, ANY IMPLIED WARRANTIES OF MERCHANTABILITY AND FITNESS FOR A PARTICULAR PURPOSE ARE EXCLUDED. SOME STATES DO NOT ALLOW LIMITATIONS ON HOW LONG AN IMPLIED WARRANTY LASTS, SO THE ABOVE LIMITATION MAY NOT APPLY TO YOU.

JET SHALL IN NO EVENT BE LIABLE FOR DEATH, INJURIES TO PERSONS OR PROPERTY, OR FOR INCIDENTAL, CONTINGENT, SPECIAL, OR CONSEQUENTIAL DAMAGES ARISING FROM THE USE OF OUR PRODUCTS. SOME STATES DO NOT ALLOW THE EXCLUSION OR LIMITATION OF INCIDENTAL OR CONSEQUENTIAL DAMAGES, SO THE ABOVE LIMITATION OR EXCLUSION MAY NOT APPLY TO YOU.

JET sells through distributors only. The specifications listed in JET printed materials and on official JET website are given as general information and are not binding. JET reserves the right to effect at any time, without prior notice, those alterations to parts, fittings, and accessory equipment which they may deem necessary for any reason whatsoever. JET® branded products are not sold in Canada by JPW Industries, Inc.

Product Listing with Warranty Period

90 Days – Parts; Consumable items
1 Year – Motors; Machine Accessories
2 Year – Metalworking Machinery; Electric Hoists, Electric Hoist Accessories; Woodworking Machinery used for industrial or commercial purposes
5 Year – Woodworking Machinery
Limited Lifetime – JET Parallel clamps; VOLT Series Electric Hoists; Manual Hoists; Manual Hoist Accessories; Shop Tools; Warehouse & Dock products; Hand Tools; Air Tools

NOTE: JET is a division of JPW Industries, Inc. References in this document to JET also apply to JPW Industries, Inc., or any of its successors in interest to the JET brand.

This page intentionally left blank.



427 New Sanford Road
LaVergne, Tennessee 37086
Phone: 800-274-6848
www.jettools.com