

## Model DC10WD Parts List

A = Standard Equipment

O = Circuit Diagram

Item#	Part#	Description	Q'ty	Unit
001	807B57-2	CHARGING CONDITION LABEL	1	PC.
002	143244-0	CHARGER CASE COMPLETE	1	PC.
	D10	INC. 3		
003	455959-0	LENZ	1	PC.
004	620421-6	CHARGING CIRCUIT	1	PC.
	D10	INC. 5,6		
005	647306-1	VARISTOR	1	PC.
006	652804-2	FUSE	1	PC.
007	667982-5	VINYL CORD #18-2-2.0	1	PC.
008	455958-2	CHARGER CASE COVER	1	PC.
010	266346-6	TAPPING SCREW BT 4X20	4	PC.
011	286255-3	CAP 13	4	PC.
E01	807B61-1	CAUTION LABEL	1	

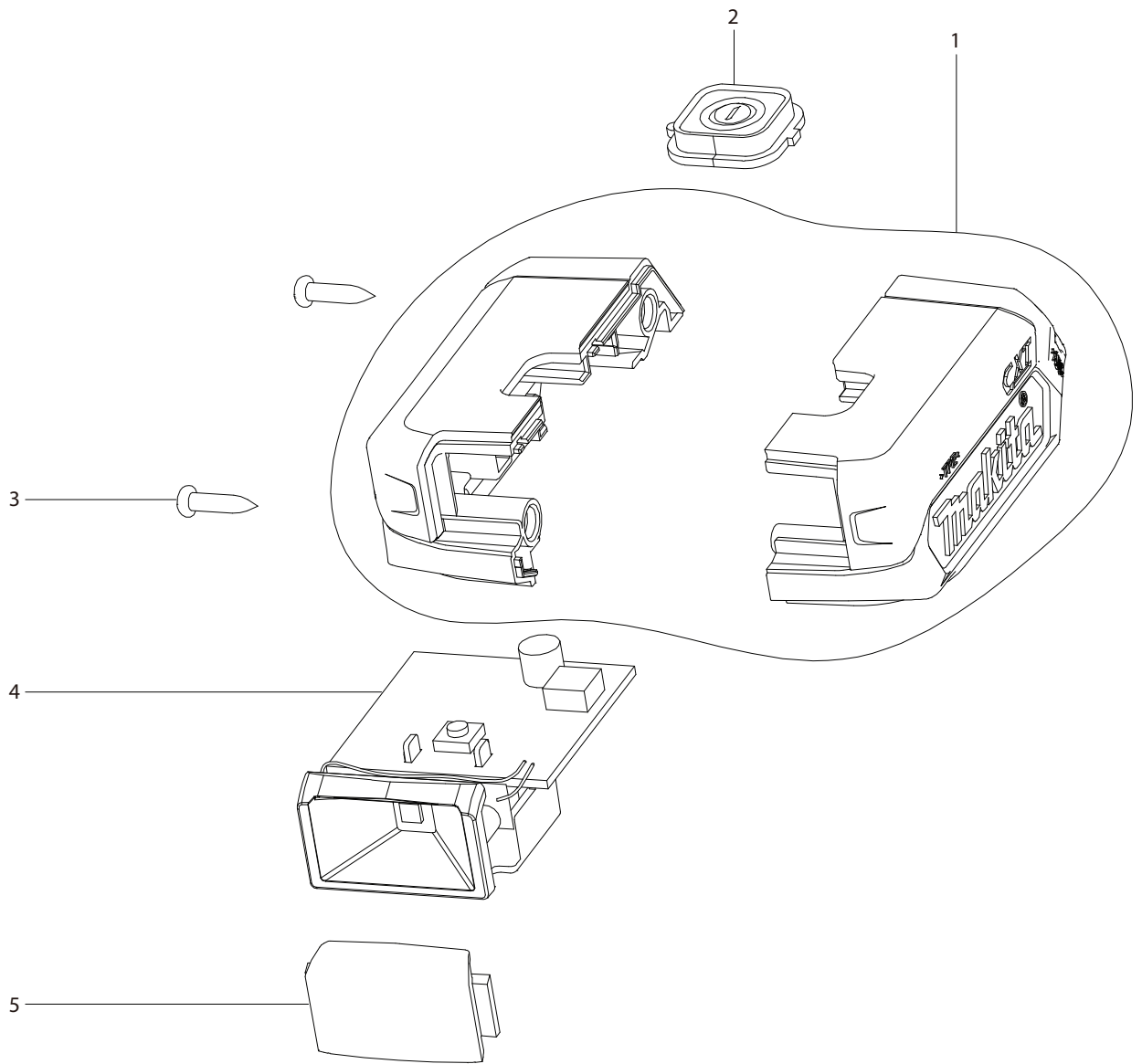

## Model ML103 Parts List

A = Standard Equipment

O = Circuit Diagram

Item#	Part#	Description	Q'ty	Unit
001	GM00001496	HOUSING L/R ASS' Y ROS81030003	1	PC.
002	GM00001495	SWITCH HOLDER ASSY ROS81030002	1	PC.
003	GM00001024	SCREW 3X12 B0130120202	2	PC.
004	GM00001493	MAIN CIRCUIT ASSY ROS81030001	1	PC.
005	GM00001492	LENZ ROS81030000	1	PC.

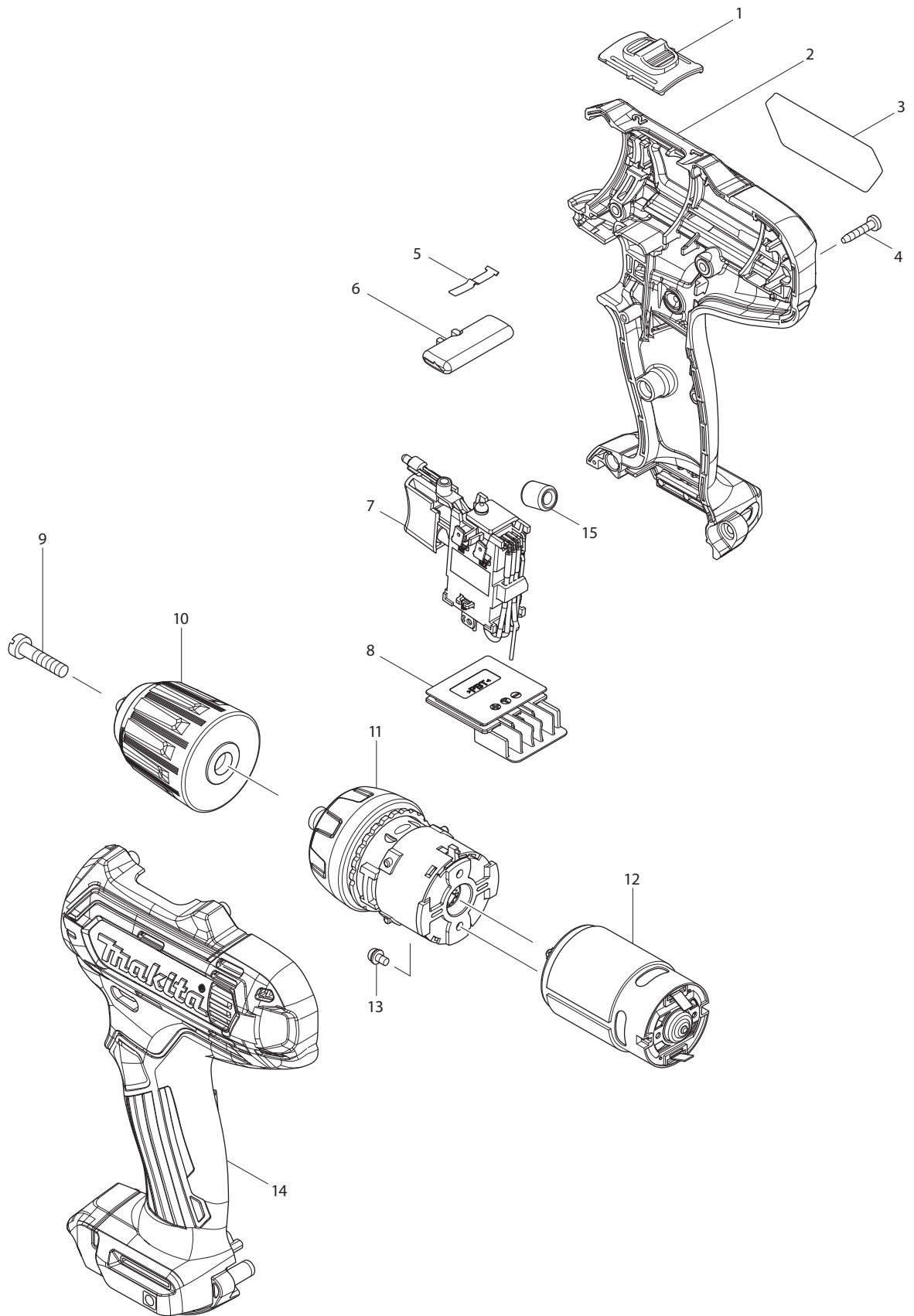

## Model FD05R1/Z Parts list

A = Standard Equipment

O = Circuit Diagram

Item#	Part#	Description	Q'ty	Unit
001	126233-0	SPEED CHANGE LEVER ASSEMBLY	1	PC.
	C10 231433-0	COMPRESSION SPRING 4	2	PC.
002	183B50-3	HOUSING SET	1	
	C10 252126-6	HEX. LOCKING NUT M4-7	2	PC.
	D10	INC. 14		
003	851H34-2	FD05 NAME PLATE	1	
004	266429-2	TAPPING SCREW 3X16	9	PC.
005	232239-9	LEAF SPRING	1	PC.
006	456039-5	F/R CHANGE LEVER	1	
007	632F43-6	SWITCH UNIT	1	
	C10 620463-0	LED CIRCUIT	1	
008	644813-5	TERMINAL	1	
009	251451-2	- PAN HEAD SCREW M5X22	1	PC.
010	763228-8	KEYLESS DRILL CHUCK 10	1	
011	123503-8	GEAR ASS'Y	1	
012	629169-7	DC MOTOR	1	
013	911003-8	PAN HEAD SCREW M3X6	2	PC.
014	183B50-3	HOUSING SET	1	
	C10 252126-6	HEX. LOCKING NUT M4-7	2	PC.
	D10	INC. 2		
A01	251314-2	+ SCREW M4X12	1	PC.
A02	346909-5	HOOK	1	
A04	456128-6	BATTERY COVER	1	(FD05R1)
A05	***DC10WD	DC10WD BATTERY CHARGER	1	(FD05R1)
A06	BL1021B	BATTERY BL1021B	2	(FD05R1)
A07	821661-1	PLASTIC CARRYING CASE	1	(FD05R1)
	C10 417724-5	LATCH	2	PC. (FD05R1)

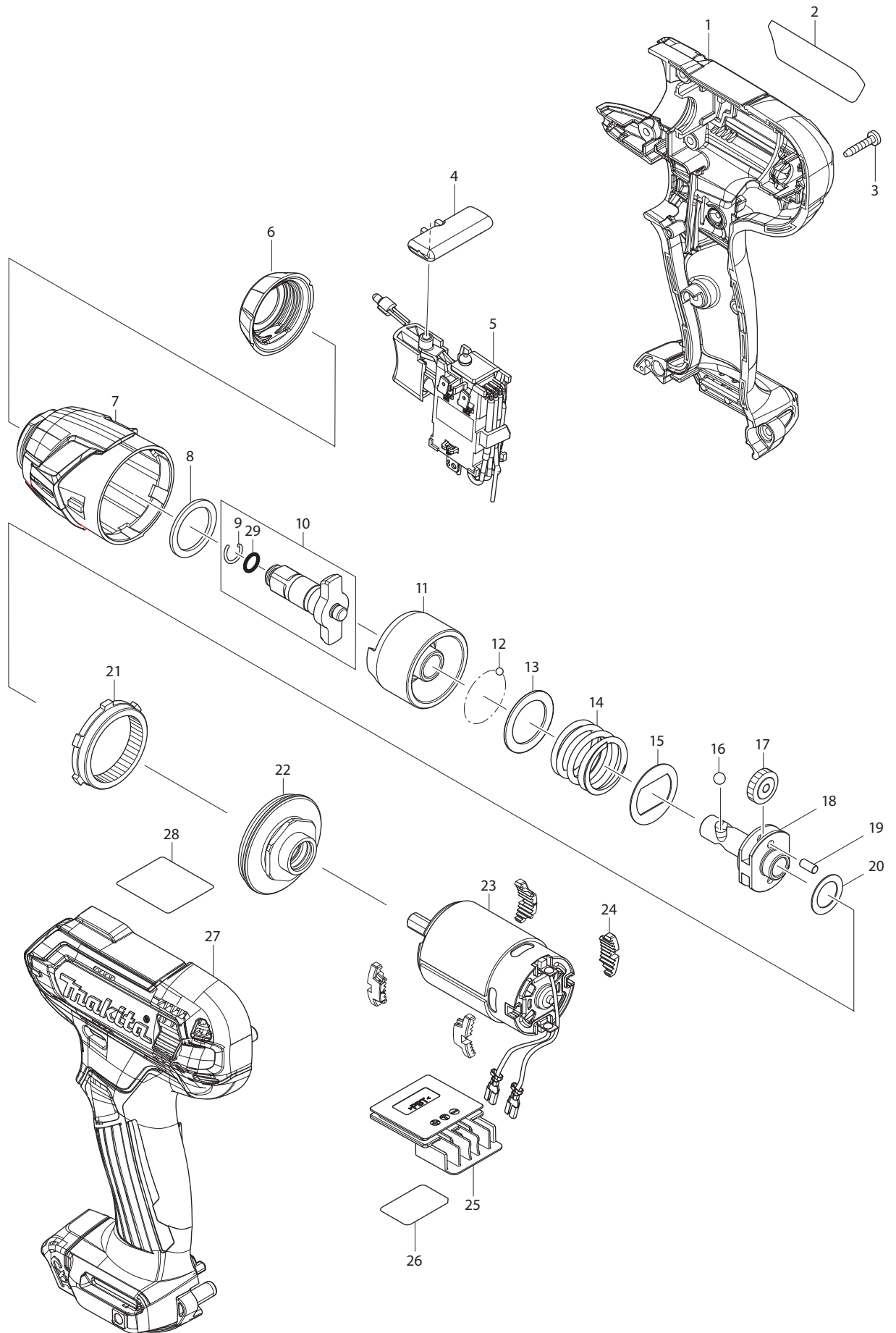

## Model WT02 R1/Z Parts List

A = Standard Equipment

O = Circuit Diagram

Item#	Part#	Description	Q'ty Unit
001	183J75-5	HOUSING SET	1 PC.
	C10 252126-6	HEX. LOCKING NUT M4-7	2 PC.
	D10	INC. 27	
002	854M37-5	WT02 NAME PLATE	1 PC.
003	266429-2	TAPPING SCREW 3X16	8 PC.
004	456039-5	F/R CHANGE LEVER	1 PC.
005	632M06-4	SWITCH UNIT	1 PC.
006	422228-4	BUMPER	1 PC.
007	140B03-5	HAMMER CASE COMPLETE	1 PC.
008	261140-1	NYLON WASHER 20	1 PC.
009	233943-3	RING SPRING 8	1 PC.
010	135932-3	ANVIL ASS'Y	1 PC.
	D10	INC. 9,29	
011	324894-2	HAMMER	1 PC.
012	216019-1	STEEL BALL 3	24 PC.
013	267380-9	FLAT WASHER 20	1 PC.
014	234064-4	COMPRESSION SPRING 21	1 PC.
015	267813-4	WASHER 21	1 PC.
016	216002-8	STEEL BALL 4.8	2 PC.
017	226190-3	SPUR GEAR 18	2 PC.
018	327127-4	SPINDLE	1 PC.
019	268217-3	PIN 3.5	2 PC.
020	253052-2	FLAT WASHER 12	1 PC.
021	226191-1	INTERNAL GEAR 45	1 PC.
022	140B04-3	BEARING BOX COMPLETE	1 PC.
	C10 213188-9	O-RING 13	1 PC.
023	632L96-1	MOTOR COMPLETE	1 PC.
024	422273-9	CUSHION	4 PC.
025	644813-5	TERMINAL	1 PC.
026	854M44-8	WT02 SERIAL NO. LABEL	1 PC.
027	183J75-5	HOUSING SET	1 PC.
	C10 252126-6	HEX. LOCKING NUT M4-7	2 PC.
	D10	INC. 1	
028	817D86-9	CAUTION LABEL	1 PC.
029	213960-9	O RING 5	1 PC.
A01	266622-8	+ TRUSS HEAD SCREW M4X12	1 PC.
A02	346909-5	HOOK	1 PC.
A03	831497-0	TOOL BAG	1 PC. (WT02R1)
A07	***DC10WD	DC10WD BATTERY CHARGER	1 PC. (WT02R1)
	D10	COMPO-PARTS	
A08	BL1021B	BATTERY BL1021B SET (197414-3)	2 PC. (WT02R1)
A09	456128-6	BATTERY COVER	2 PC. (WT02R1)