

# OHIO STEEL INDUSTRIES

**PROFESSIONAL GRADE**



## 60T 24 x 60 LAWN ROLLER



**READ AND FOLLOW ALL SAFETY RULES AND OPERATING  
INSTRUCTIONS BEFORE USING THIS EQUIPMENT**

# ***Safety Rules***



**This is the safety alert symbol. It is used to alert you to potential personal injury hazards. Obey all safety messages that follow this symbol to avoid possible injury or death.**

Read and understand all safety rules and operating instructions before using this tractor attachment.

Follow all safety rules and operating instructions provided by your tractor's manufacturer when using attachment.

Never allow children or untrained persons to operate vehicle or attachment.

Do not carry passenger on vehicle or attachment.

Avoid sudden turns or maneuvers.

Do not remove warning decals from product.

Do not tow attachment on public roadways.

Check product for worn, loose or damaged parts before each use. If any damage is present, repair the product before using.

Check product for loose or missing fasteners before each use. Tighten or replace fasteners as needed before using.

# Carton Contents

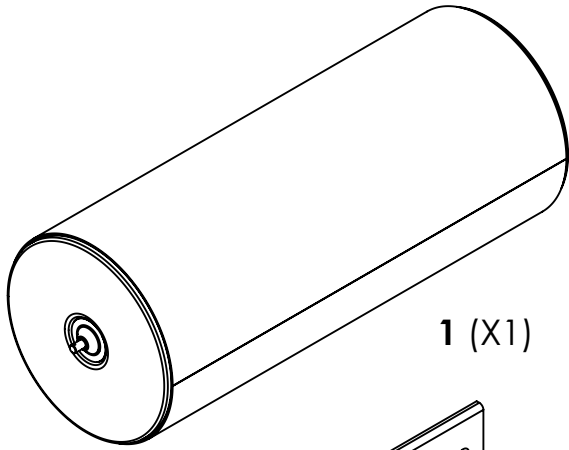

1 (X1)

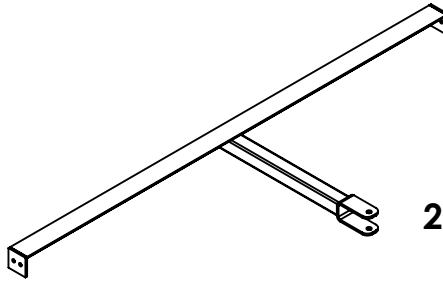

2 (X1)

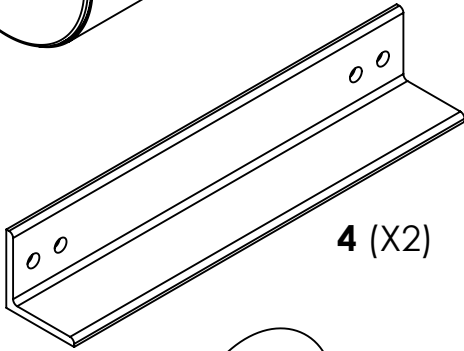

4 (X2)

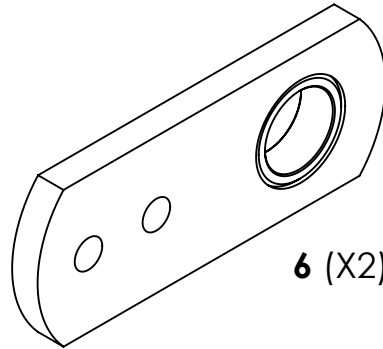

6 (X2)

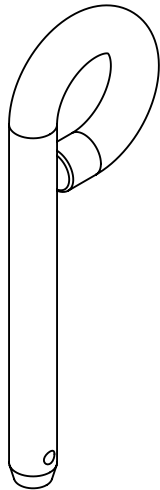

8 (X1)

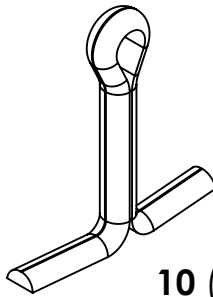

10 (X2)

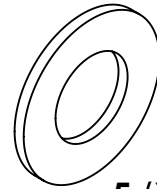

5 (X2)

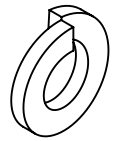

11 (X8)

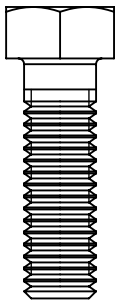

7 (X8)

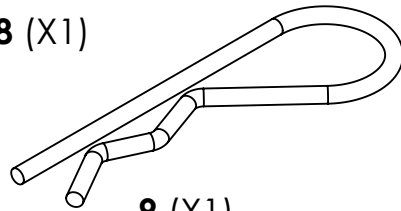

9 (X1)

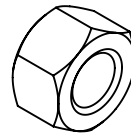

12 (X8)

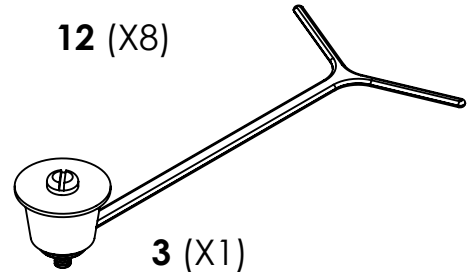

3 (X1)

## TOOLS REQUIRED FOR ASSEMBLY

- 3/8" Wrench or Socket
- Pliers

# Assembly Instructions

- 1** Attach axle bars (6) to side angles (4) using 3/8" bolts (7), lockwashers (11) and 3/8" nuts (12).

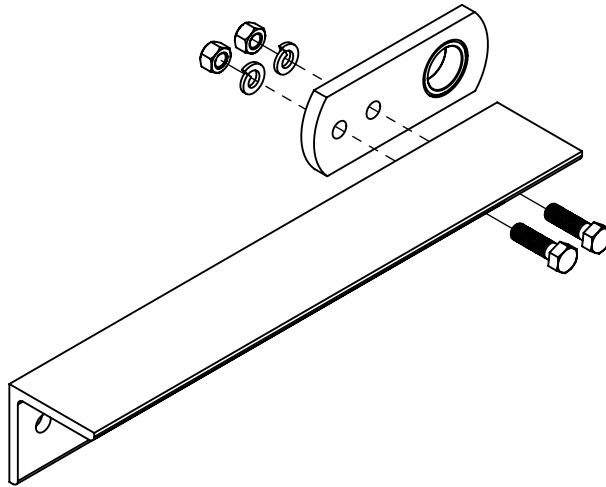

- 2** Slide both side bars over axle with flanges of the bearing towards the inside of the roller head, add washers (5) and lock in place by inserting and spreading ends of cotter pins (10).

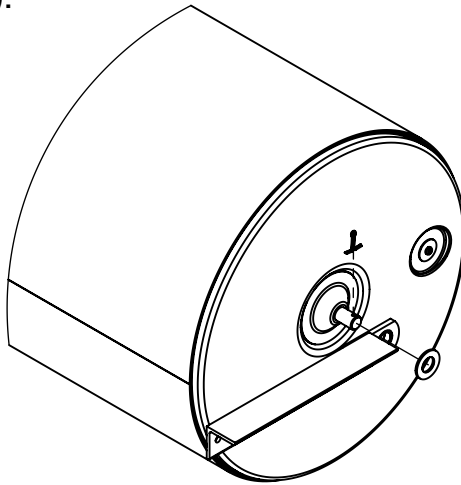

- 3** Attach hitch assembly (2) to side bars using 3/8" bolts (7), lockwashers (11) and 3/8" nuts (12). Install hitch pin (8) and hairpin cotter (9) as shown.

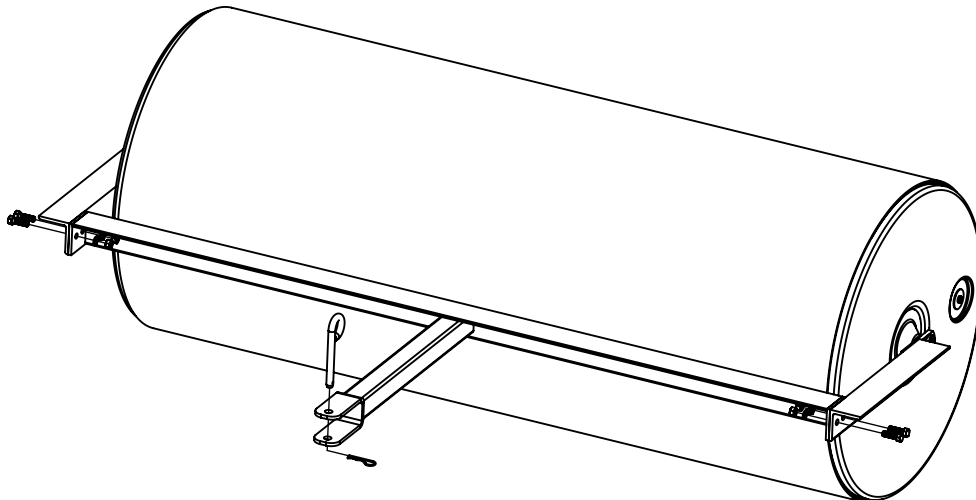

# Operating Instructions

## Before Using Lawn Roller:

Read all Safety Rules found on page 1.

Though most rollers are filled with water, we recommend adding Ethylene Glycol Anti-Freeze with the water. This will protect the tank from damage during cold weather. It is also recommended that the anti-freeze used, contain a rust inhibitor to protect the inside of the tank against rust. If the roller is filled with water only, it must be drained whenever the temperature drops below 32 degrees F. (0 degrees C). The roller weighs approximately 1,150 pounds when filled. Safe disposal of the antifreeze is recommended. Please follow the Anti-Freeze manufacturers warnings and disposal methods.

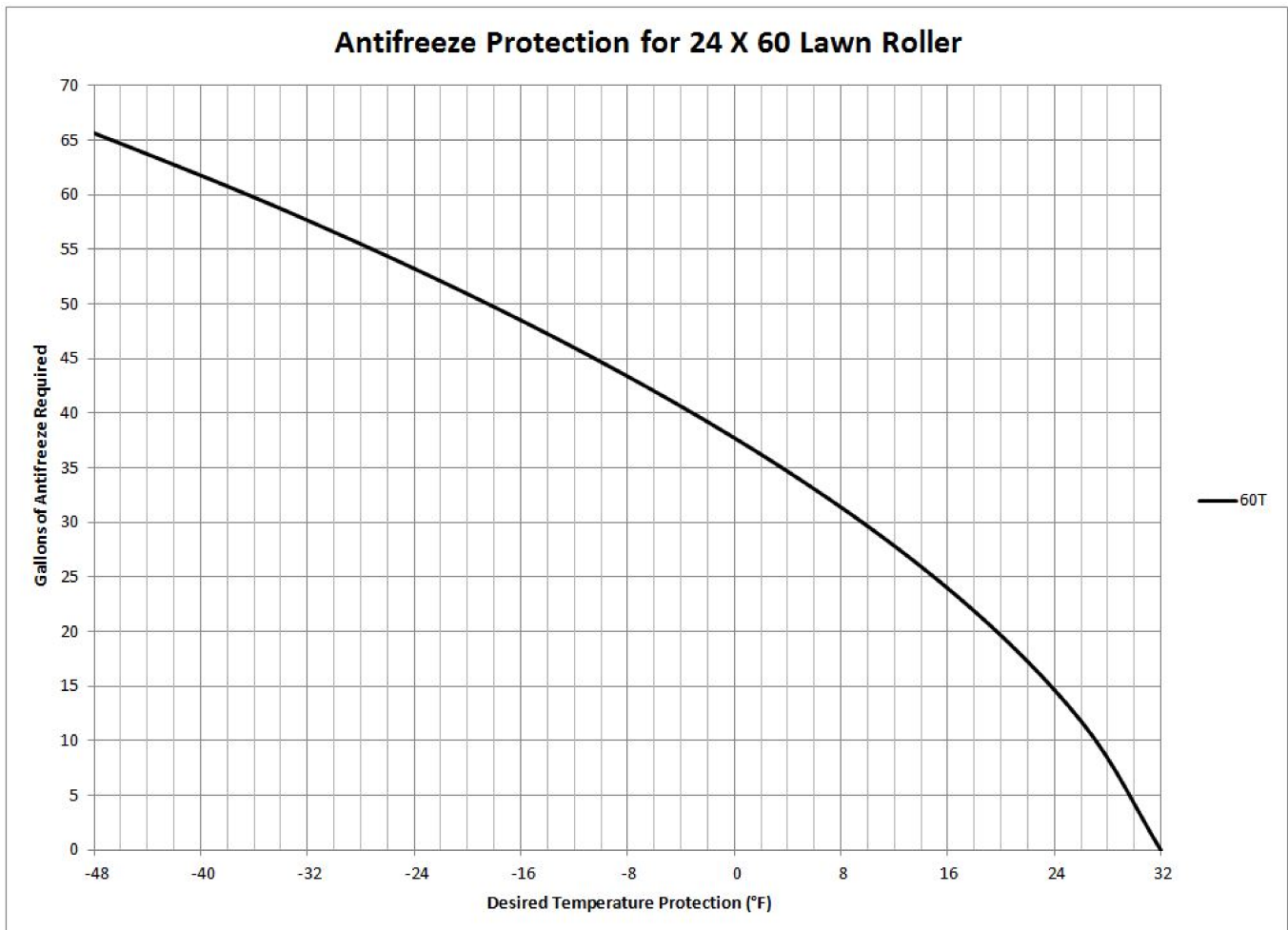

# Warranty

If this product fails due to a defect in material or workmanship within TWO YEARS from the date of purchase, we will at our option repair or replace it free of charge.

This warranty does not cover:

- Repairs necessary because of operator abuse or negligence
- Equipment use for commercial or rental purposes.
- Paint that is worn or faded due to normal use or exposure.

To arrange for product repair call 1-800-652-2321, or return this product to place of purchase for replacement.

This warranty gives you specific legal rights, and you may also have other rights which may vary from state to state. This Warranty applies only while this product is in use in the United States.

In the space below record the purchase date of your Lawn Roller.

Model Number: 60T

Purchase Date: \_\_\_\_\_

Keep this Owner's Manual and your receipt in a safe place for future reference.

After the two year warranty period all replacement parts may be ordered by calling **1-800-652-2321**.

When ordering replacement parts, always give the following information:

- Product: 24X60 LAWN ROLLER
- Model Number: 60T
- Part Number: \_\_\_\_\_
- Part Description: \_\_\_\_\_

# Repair Parts

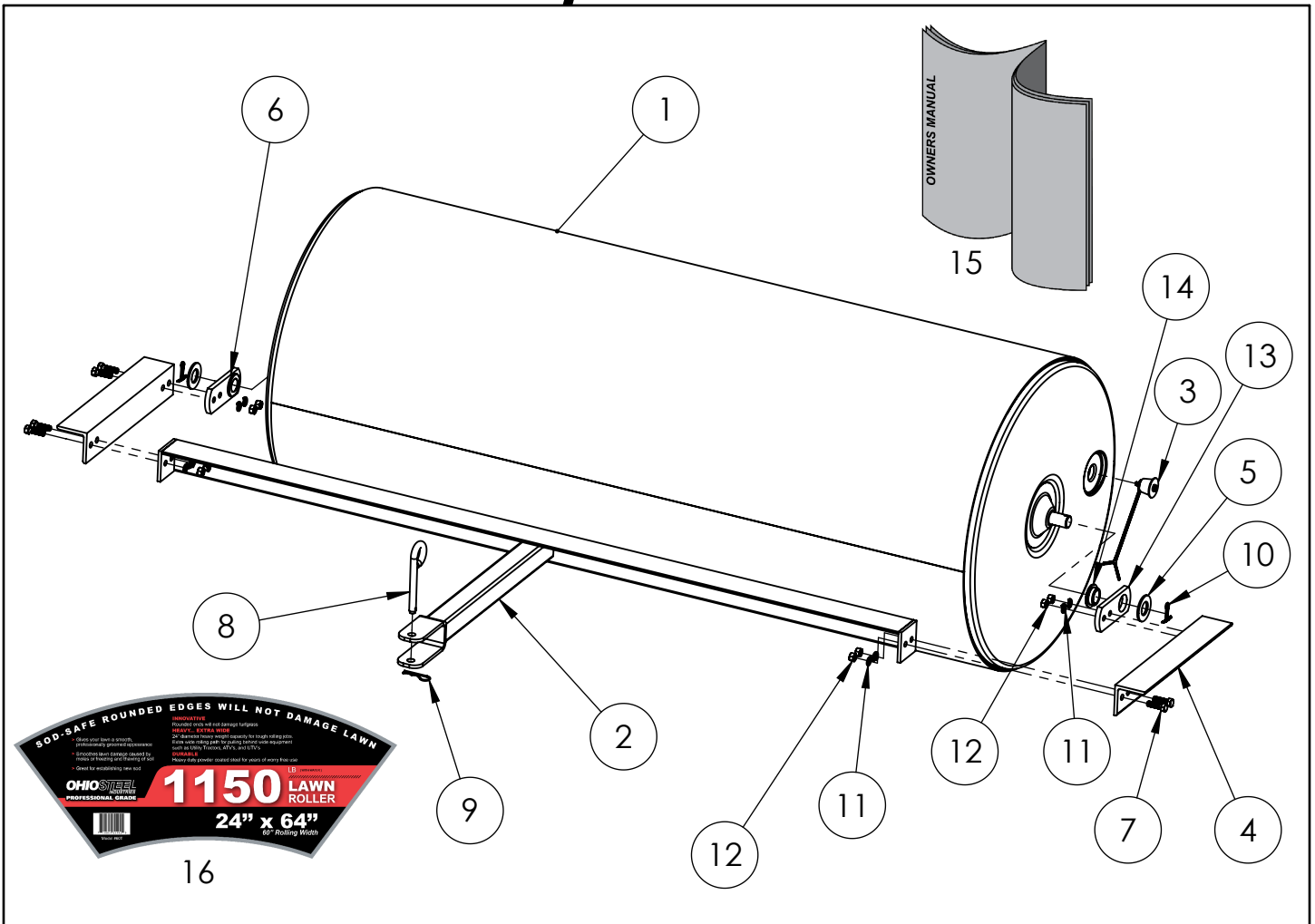

ITEM NO.	PART NUMBER	DESCRIPTION	QTY.
1	6000121	DRUM, ROLLER	1
2	6000123	HITCH ASSEMBLY	1
3	50401	PLUG, FLUSH	1
4	6000135	ANGLE, SIDE	2
5	300076	WASHER, 1" SAE	2
6	6003311	AXLE BAR ASSEMBLY (INCL. 6000136 & 304281)	2
7	6000292	HEX BOLT, 3/8-16 x 1-1/4"	8
8	6000533	PIN, HITCH	1
9	300084	HAIRPIN COTTER, 0.093" X 2-5/16"	1
10	300087	COTTER PIN, 3/16" X 1-1/2"	2
11	300078	3/8" SPLIT LOCK WASHER	8
12	300069	HEX NUT, 3/8-16	8
13	6000136	BAR, AXLE	
14	304281	BUSHING	
15	6000164	OWNERS MANUAL	1
16	6000163	PRODUCT DECAL	1

# ***Notes***



**OHIO**STEEL  
INDUSTRIES

Designed And Tested In Columbus, Ohio

Manufactured In The U.S.A. From Domestic  
And Imported Components

***www.OHIOSTEEL.com***

**(800) 652-2321**