



Count on it.

Operator's Manual

**TimeCutter® HD MR4800,
MR5400, and MR6000 Riding
Mower**

Model No. 75211—Serial No. 40000000 and Up

Model No. 75212—Serial No. 40000000 and Up

Model No. 75213—Serial No. 40000000 and Up

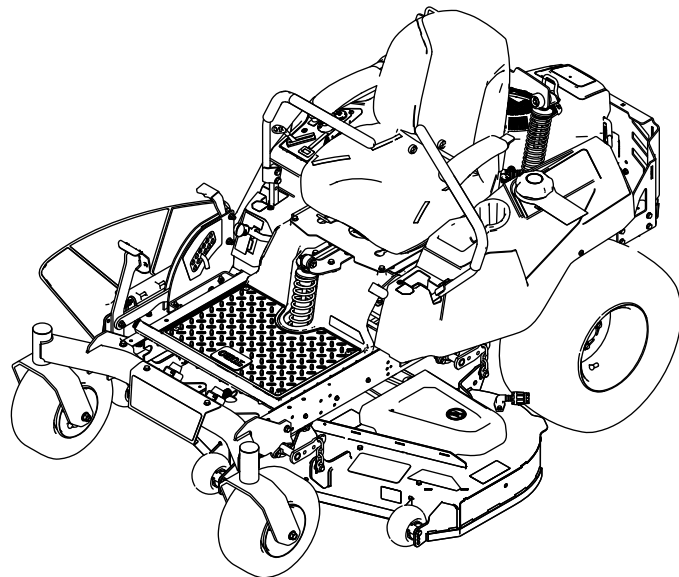

▲ WARNING

CALIFORNIA Proposition 65 Warning

This product contains a chemical or chemicals known to the State of California to cause cancer, birth defects, or reproductive harm.

The engine exhaust from this product contains chemicals known to the State of California to cause cancer, birth defects, or other reproductive harm.

NOTE: THE ENGINE ON THIS PRODUCT HAS BEEN MODIFIED FOR USE AT ABOVE 5,000 FEET ELEVATION. IF USING BELOW 5,000 FEET, IT MUST BE REVISED BACK TO ORIGINAL SPECIFICATIONS.

127-9963

decal127-9363

This spark ignition system complies with Canadian ICES-002

It is a violation of California Public Resource Code Section 4442 or 4443 to use or operate the engine on any forest-covered, brush-covered, or grass-covered land unless the engine is equipped with a spark arrester, as defined in Section 4442, maintained in effective working order or the engine is constructed, equipped, and maintained for the prevention of fire.

Gross Horsepower

The gross or net horsepower of this engine was laboratory rated by the engine manufacturer in accordance with the Society of Automotive Engineers (SAE) J1940. As configured to meet safety, emission, and operating requirements, the actual engine torque on this class of mower will be significantly lower.

Go to www.Toro.com to view specifications on your mower model.

Important: If you are using a machine with a Toro engine above 1500 m (5,000 ft) for a continuous period, ensure that the High Altitude Kit has been installed so that the engine meets CARB/EPA emission regulations. The High Altitude Kit increases engine performance while preventing spark-plug fouling, hard starting, and increased emissions. Once you have installed the kit, attach the high-altitude label next to the serial decal on the machine. Contact any Authorized Toro Service Dealer to obtain the proper High Altitude Kit and high-altitude label for your machine. To locate a dealer convenient to you, access our website at www.Toro.com or contact our Toro Customer Care Department at the number(s) listed in your Emission Control Warranty Statement.

Remove the kit from the engine and restore the engine to its original factory configuration when running the engine under 1500 m (5,000 ft). Do not operate an engine that has been converted for high-altitude use at lower altitudes; otherwise, you could overheat and damage the engine.

If you are unsure whether or not your machine has been converted for high-altitude use, look for the following label.

Introduction

This rotary-blade, riding lawn mower is intended to be used by residential homeowners or hired operators. It is designed primarily for cutting grass on well-maintained lawns on residential or commercial properties. It is not designed for cutting brush or for agricultural uses.

Read this information carefully to learn how to operate and maintain your product properly and to avoid injury and product damage. You are responsible for operating the product properly and safely.

You may contact Toro directly at www.Toro.com for product safety and operation training materials, accessory information, help finding a dealer, or to register your product.

Whenever you need service, genuine Toro parts, or additional information, contact an Authorized Service Dealer or Toro Customer Service and have the model and serial numbers of your product ready. Figure 1 identifies the location of the model and serial numbers on the product. Write the numbers in the space provided.

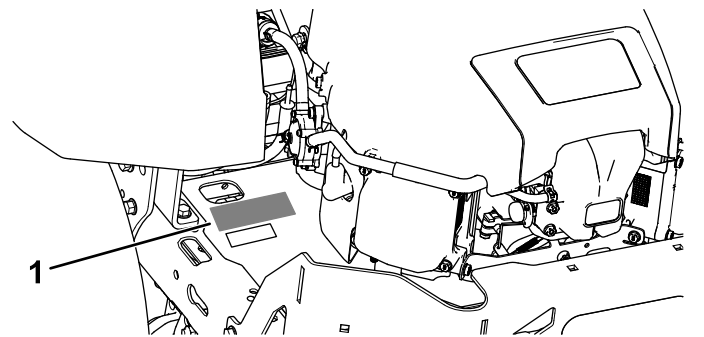

Figure 1

1. Model and serial number plate

Write the product model and serial numbers in the space below:

Model No. _____

Serial No. _____

This manual identifies potential hazards and has safety messages identified by the safety-alert symbol (Figure 2), which signals a hazard that may cause serious injury or death if you do not follow the recommended precautions.



Figure 2

g000502

1. Safety-alert symbol.

This manual uses 2 words to highlight information.

Important calls attention to special mechanical information and **Note** emphasizes general information worthy of special attention.

Contents

Safety	4
General Safety.....	4
Slope Indicator	5
Safety and Instructional Decals	6
Product Overview	11
Controls	11
Before Operation	13
Before Operation Safety	13
Recommended Fuel.....	13
Using Stabilizer/Conditioner	13
Filling the Fuel Tank	14
Checking the Engine-Oil Level.....	14
Breaking in a New Machine.....	14
Think Safety First.....	14
Using the Safety-Interlock System.....	15
Positioning the Seat	15
Adjusting the MyRide™ Suspension System.....	16
Adjusting the Motion-Control Levers.....	17
During Operation	17
During Operation Safety	17
Operating the Parking Brake	18
Operating the Mower Blade-Control Switch (PTO)	19
Operating the Throttle.....	19
Operating the Choke.....	19
Operating the Ignition Switch	20
Starting and Shutting Off the Engine.....	20
Using the Motion-Control Levers	21
Driving the Machine	21
Using the Smart Speed™ Control System	22
Stopping the Machine	23
Using the Side Discharge	23
Adjusting the Height of Cut	23
Adjusting the Anti-Scalp Rollers	24
Using Attachments and Accessories	25
Operating Tips	25
After Operation	26
After Operation Safety	26

Pushing the Machine by Hand	27
Transporting the Machine.....	27
Loading the Machine	28
Maintenance	29
Recommended Maintenance Schedule(s)	29
Pre-Maintenance Procedures	30
Maintenance and Storage Safety.....	30
Engine Maintenance	30
Engine Safety.....	30
Servicing the Air Cleaner	30
Servicing the Engine Oil.....	31
Servicing the Spark Plug	34
Cleaning the Cooling System	35
Fuel System Maintenance	35
Replacing the In-Line Fuel Filter.....	35
Electrical System Maintenance	36
Electrical System Safety.....	36
Servicing the Battery	36
Servicing the Fuses	38
Drive System Maintenance	39
Checking the Tire Pressure	39
Mower Maintenance.....	39
Servicing the Cutting Blades.....	39
Leveling the Mower Deck	42
Removing the Mower Deck	43
Installing the Mower Deck.....	44
Replacing the Grass Deflector.....	45
Mower Belt Maintenance	46
Inspecting the Belts	46
Replacing the Mower Belt.....	46
Cleaning	47
Washing the Underside of the Mower	47
Cleaning the Suspension System	47
Disposing of Waste.....	47
Storage	48
Cleaning and Storage	48
Troubleshooting	49
Schematics	51

Safety

This machine has been designed in accordance with ANSI B71.1-2012.

General Safety

This product is capable of amputating hands and feet and of throwing objects. Always follow all safety instructions to avoid serious personal injury.

Using this product for purposes other than its intended use could prove dangerous to you and bystanders.

- Read and understand the contents of this *Operator's Manual* before you start the engine. Ensure that everyone using this product knows how to use it and understands the warnings.
- Do not put your hands or feet near moving components of the machine.
- Do not operate the machine without all guards and other safety protective devices in place and working on the machine.
- Keep clear of any discharge opening. Keep bystanders a safe distance away from the machine.
- Keep children out of the operating area. Never allow children to operate the machine.
- Stop the machine and shut off the engine before servicing, fueling, or unclogging the machine.

Improperly using or maintaining this machine can result in injury. To reduce the potential for injury, comply with these safety instructions and always pay attention to the safety-alert symbol, which means Caution, Warning, or Danger—personal safety instruction. Failure to comply with these instructions may result in personal injury or death.

You can find additional items of safety information in their respective sections throughout this manual.

Slope Indicator

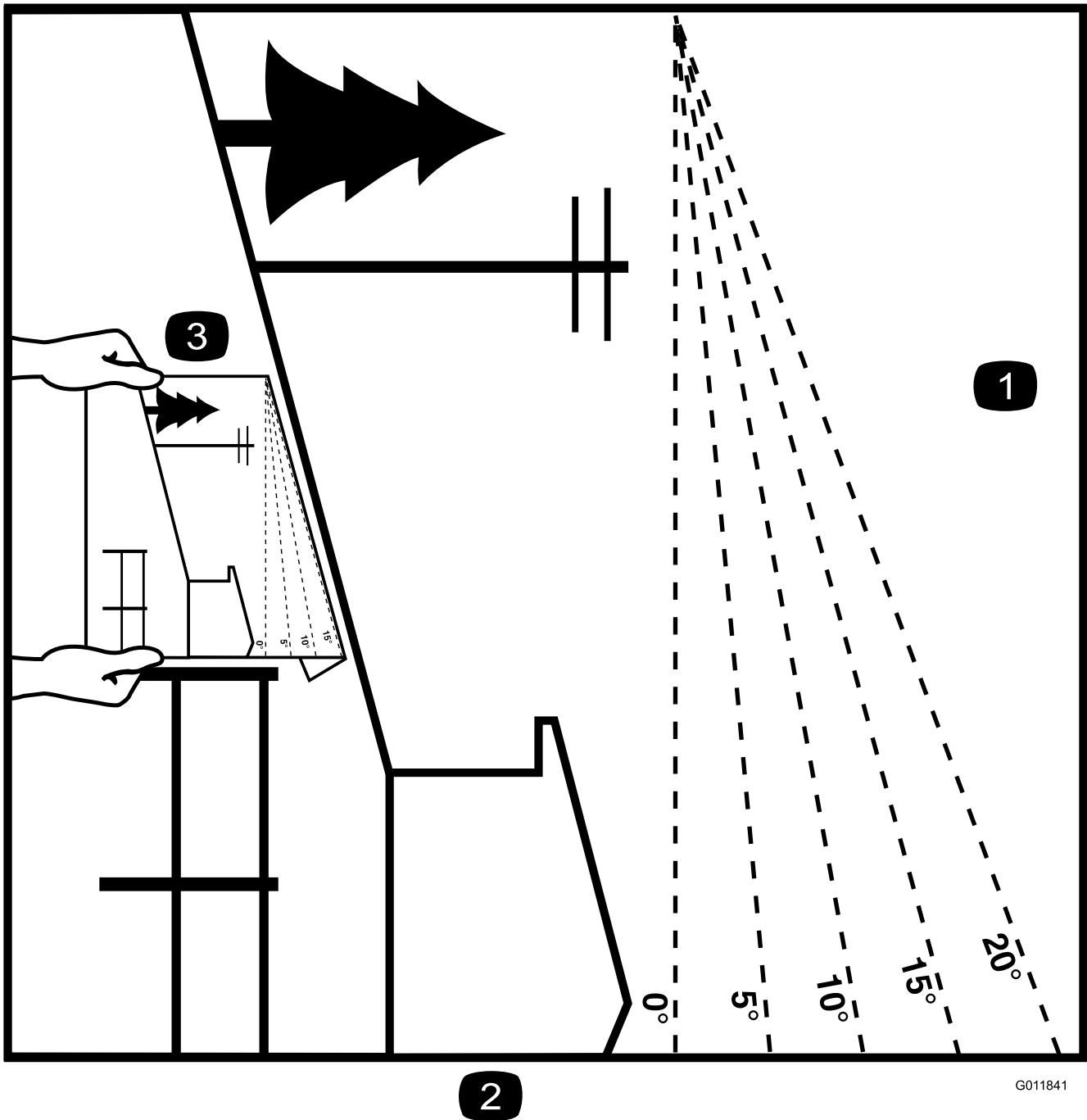

2

G011841

g011841

Figure 4

This page may be copied for personal use.

1. The maximum slope you can safely operate the machine on is **15 degrees**. Use the slope chart to determine the degree of slope of hills before operating. **Do not operate this machine on a slope greater than 15 degrees.** Fold along the appropriate line to match the recommended slope.
2. Align this edge with a vertical surface, a tree, building, fence pole, etc.
3. Example of how to compare slope with folded edge

Safety and Instructional Decals



Safety decals and instructions are easily visible to the operator and are located near any area of potential danger. Replace any decal that is damaged or missing.

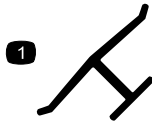

Manufacturer's Mark

decalocemmark

1. Indicates the blade is identified as a part from the original machine manufacturer.

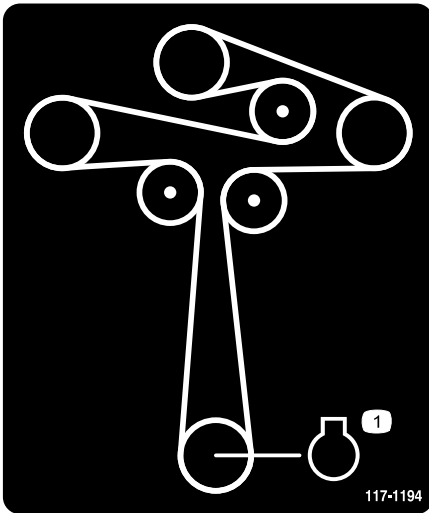

117-1194

decal117-1194

1. Engine



121-2989

decal121-2989b

1. Bypass lever position for pushing the machine
2. Bypass lever position for operating the machine



Battery Symbols

Some or all of these symbols are on your battery.

- | | |
|----------------------------------------|---------------------------------------------------------------------------------|
| 1. Explosion hazard | 6. Keep bystanders a safe distance away from the battery. |
| 2. No fire, open flame, or smoking | 7. Wear eye protection; explosive gases can cause blindness and other injuries. |
| 3. Caustic liquid/chemical burn hazard | 8. Battery acid can cause blindness or severe burns. |
| 4. Wear eye protection. | 9. Flush eyes immediately with water and get medical help fast. |
| 5. Read the <i>Operator's Manual</i> . | 10. Contains lead; do not discard. |



130-0731

decal130-0731

1. Warning—thrown object hazard; keep the deflector shield in place.
2. Cutting hazard of hand or foot, mower blade—keep away from moving parts.

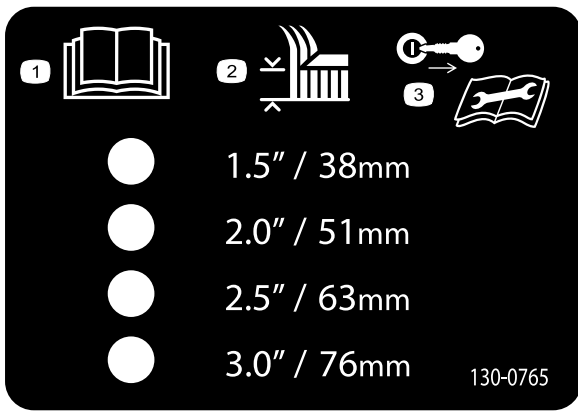

130-0765

decal130-0765

1. Read the *Operator's Manual*.
2. Height-of-cut selection
3. Remove the key from the ignition and read the *Operator's Manual* before performing maintenance.

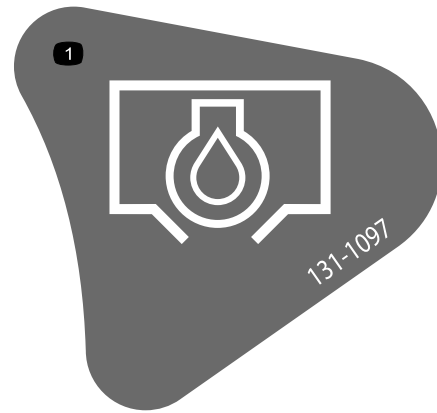

131-1097

decal131-1097

1. Oil drain

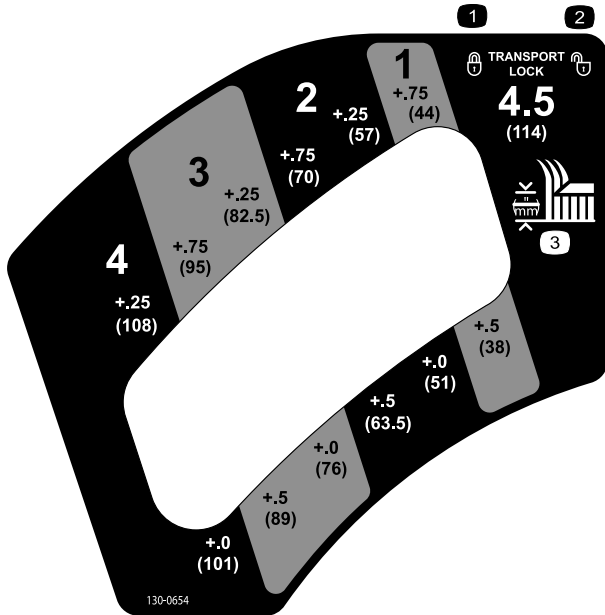

130-0654

decal130-0654

1. Transport—lock
2. Transport—unlock
3. Height of cut

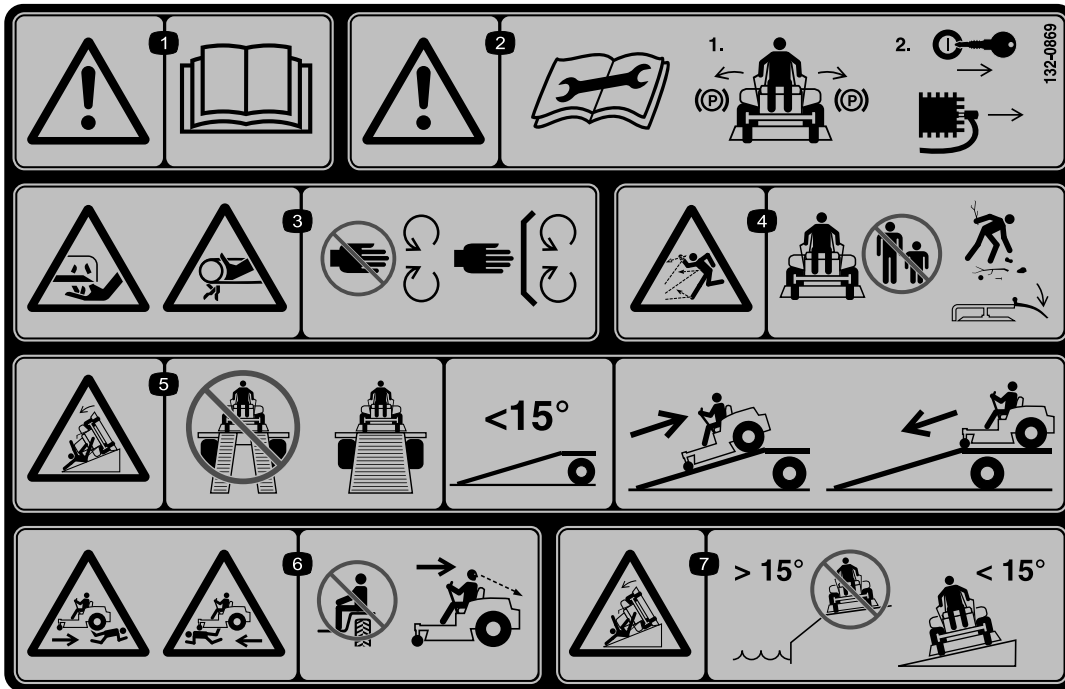

132-0869

decal132-0869

1. Warning—read the *Operator's Manual*.
2. Warning—read the instructions before servicing or performing maintenance; move the motion-control levers to the park (brake) position, remove the ignition key, and disconnect the spark-plug wire.
3. Cutting/dismemberment hazard, mower blade; entanglement hazard, belt—stay away from moving parts and keep all guards and shields in place.
4. Thrown object hazard—keep bystanders a safe distance away from the machine, pick up debris before operating, and keep the deflector in place.
5. Ramp hazard—When loading onto a trailer, do not use split ramps. Only use a full-width ramp wide enough for the machine. Ramp angle with the ground should be less than 15 degrees. Back up the ramp and drive forward off the ramp.
6. Crushing/dismemberment hazard of bystanders, in reverse and forward—do not carry passengers, look behind and down when reversing.
7. Tipping hazard—do not use the machine near drop-offs with slopes greater than 15 degrees or near water; only use on slopes less than 15 degrees.

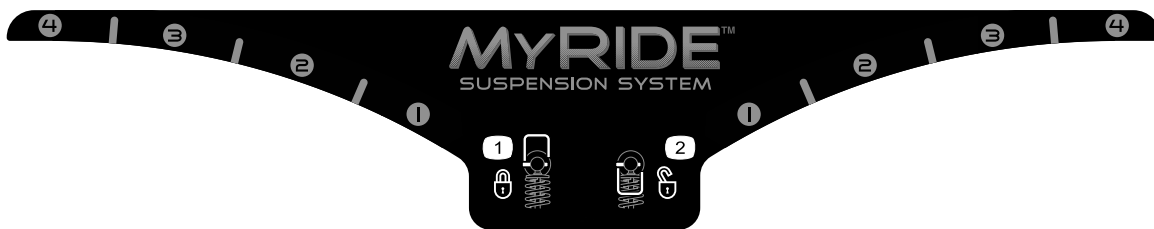

133-5198

decal133-5198

1. Cam lock
2. Cam unlock

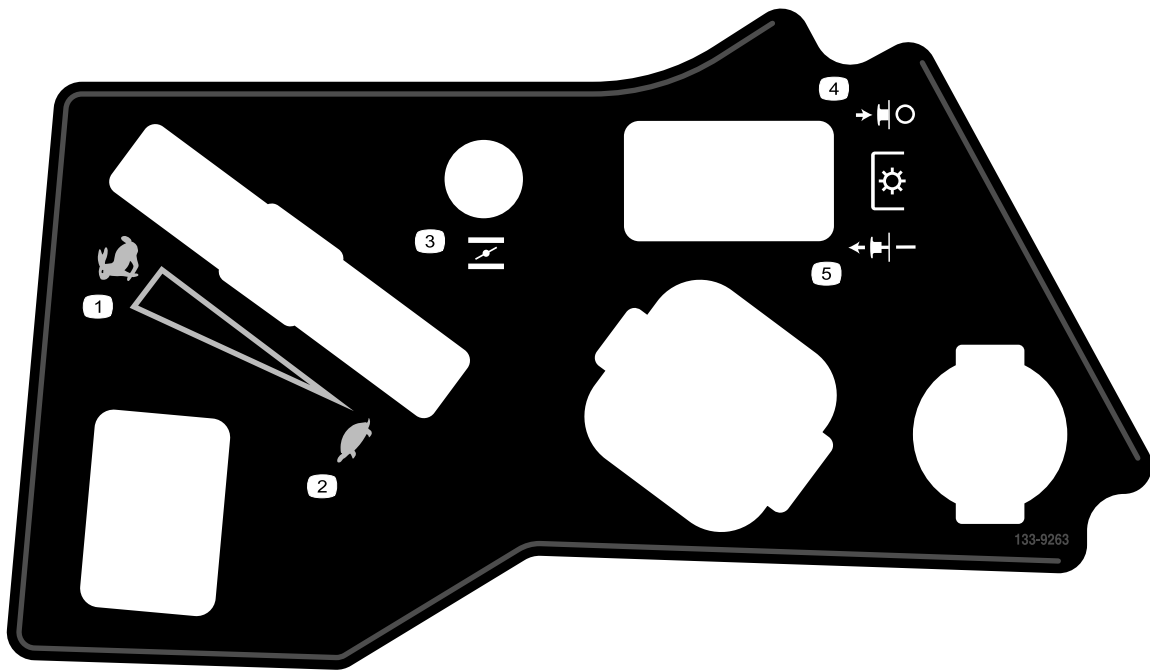

133-9263

decal133-9263

- | | |
|----------|------------------|
| 1. Fast | 4. PTO disengage |
| 2. Slow | 5. PTO engage |
| 3. Choke | |

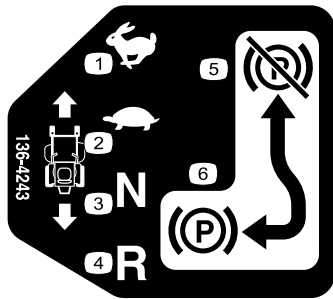

136-4243

decal136-4243

- | | |
|------------|-----------------------------|
| 1. Fast | 4. Reverse |
| 2. Slow | 5. Parking brake disengaged |
| 3. Neutral | 6. Parking brake engaged |

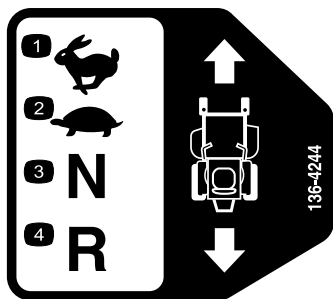

136-4244

decal136-4244

- | | |
|---------|------------|
| 1. Fast | 3. Neutral |
| 2. Slow | 4. Reverse |

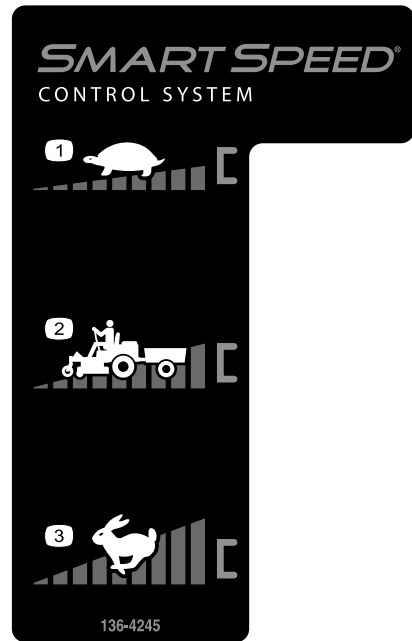

136-4245

decal136-4245

- | | |
|--------------|---------|
| 1. Slow | 3. Fast |
| 2. Transport | |

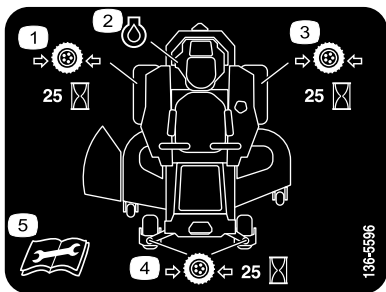

decal136-5596

136-5596

1. Check the tire pressure every 25 operating hours.
2. Engine oil
3. Check the tire pressure every 25 operating hours.
4. Check the tire pressure every 25 operating hours.
5. Read the *Operator's Manual* before performing maintenance.



decal136-9186

136-9186

1. Read the *Operator's Manual* before adding weight to the bucket.

Product Overview

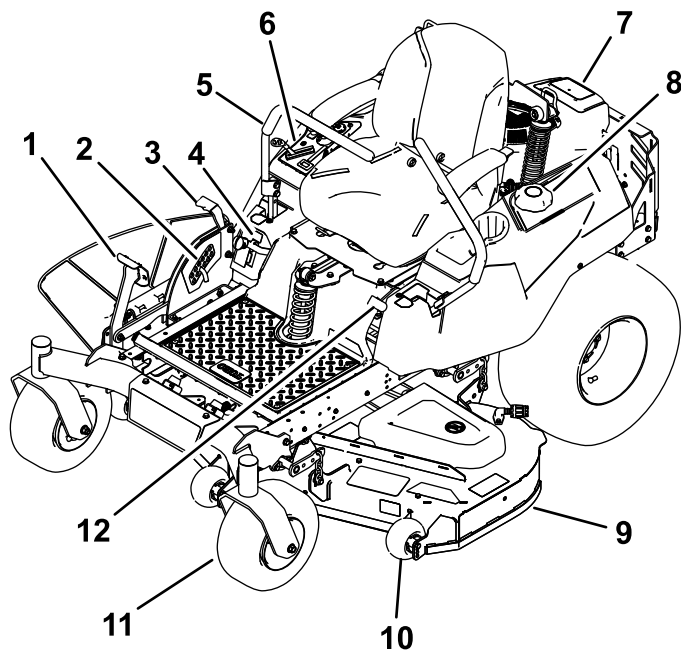

Figure 5

- | | |
|---------------------------------------|-------------------------|
| 1. Deck-lift pedal | 7. Engine |
| 2. Height-of-cut pin | 8. Fuel cap |
| 3. Height-of-cut lever/transport lock | 9. Mower deck |
| 4. Smart Speed™ lever | 10. Anti-scalp roller |
| 5. Motion-control lever | 11. Caster wheel |
| 6. Controls | 12. Parking-brake lever |

Controls

Become familiar with all controls in [Figure 6](#) and [Figure 7](#) before you start the engine and operate the machine.

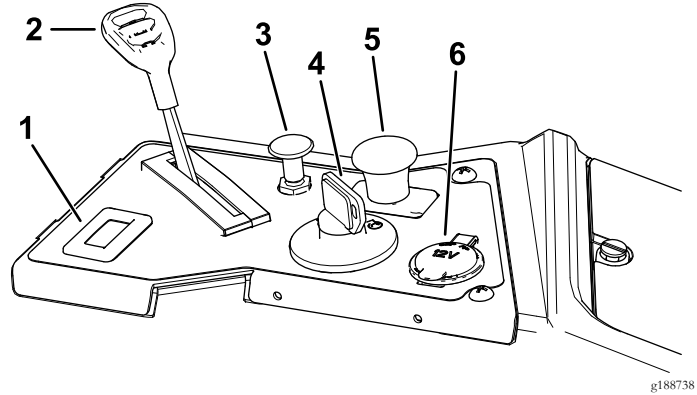

Figure 6

- | | |
|---------------------|---------------------|
| 1. Hour meter | 4. Ignition switch |
| 2. Throttle control | 5. PTO switch |
| 3. Choke control | 6. 12 V power point |

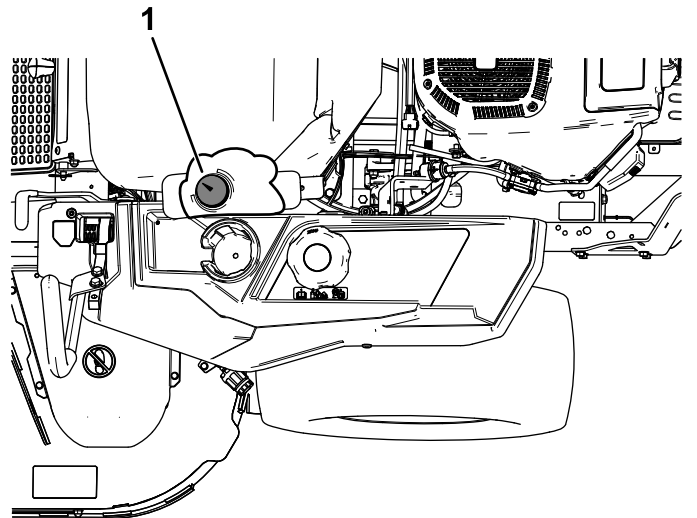

Figure 7

1. Fuel gauge

Fuel Gauge

The fuel gauge displays the amount of fuel in the tank ([Figure 7](#)).

Throttle Control

The throttle controls the engine speed, and it has a continuous-variable setting from the SLOW to FAST position ([Figure 6](#)).

Choke Control

Use the choke control to start a cold engine. Pull the choke control up to engage it. Push down on the choke control to disengage it.

Hour Meter

The hour meter records the number of hours the engine has operated. It operates when the engine is running. Use these times for scheduling regular maintenance (Figure 6).

Motion-Control Levers

The motion-control levers are speed-sensitive controls of independent wheel motors. Moving a lever forward or backward turns the wheel on the same side forward or in reverse; wheel speed is proportional to the amount the lever is moved. Move the control levers outward from the center to the NEUTRAL-LOCK position and exit the machine (Figure 5). Always position the motion-control levers into the NEUTRAL-LOCK position when you stop the machine or leave it unattended.

Parking-Brake Lever

The parking-brake lever is located on left side of the console (Figure 5). The brake lever engages a parking brake on the drive wheels.

To engage the parking brake, pull up the lever until it latches into the detent slot.

To disengage the parking brake, pull the lever out of the detent slot and toward you, then push it down.

Foot Pedal Deck-Lift System

The foot pedal deck-lift system allows you to lower and raise the deck from the seated position. You can use the foot pedal to lift the deck briefly to avoid obstacles or lock the deck in the highest height of cut or transport position (Figure 5).

Smart Speed™ Control System Lever

The Smart Speed™ Control-System lever, located below the operating position, gives you a choice to drive the machine at 3 speed ranges— trim, tow, and mow (Figure 27).

12 V Power Point

Use the power point to power 12 V accessories (Figure 6).

Important: When not using the 12 V power point, insert the rubber plug to prevent damage to the power point.

Ignition Switch

Use this switch to start the mower engine. It has 3 positions: START, RUN, and OFF.

Blade-Control Switch (Power Takeoff)

The blade-control switch (PTO) engages and disengages power to the mower blades (Figure 6).

Height-of-Cut Lever

The height-of-cut lever works with the foot pedal to lock the deck in a specific cutting height. Only adjust the height of cut while machine is not moving (Figure 5).

Attachments/Accessories

A selection of Toro approved attachments and accessories is available for use with the machine to enhance and expand its capabilities. Contact your Authorized Service Dealer or Distributor or go to www.Toro.com for a list of all approved attachments and accessories.

Operation

Note: Determine the left and right sides of the machine from the normal operating position.

Before Operation

Before Operation Safety

General Safety

- Never allow children or untrained people to operate or service the machine. Local regulations may restrict the age of the operator. The owner is responsible for training all operators and mechanics.
- Become familiar with the safe operation of the equipment, operator controls, and safety signs.
- Know how to stop the machine and shut off the engine quickly.
- Check that operator-presence controls, safety switches, and shields are attached and functioning properly. Do not operate the machine unless they are functioning properly.
- Before mowing, always inspect the machine to ensure that the blades, blade bolts, and cutting assemblies are in good working condition. Replace worn or damaged blades and bolts in sets to preserve balance.
- Inspect the area where you will use the machine and remove all objects that the machine could throw.
- Evaluate the terrain to determine the appropriate equipment and any attachments or accessories required to operate the machine properly and safely.

Fuel Safety

- To avoid personal injury or property damage, use extreme care in handling fuel. Fuel vapors are flammable and explosive.
- Extinguish all cigarettes, cigars, pipes, and other sources of ignition.
- Use only an approved fuel container.
- Do not remove the fuel cap or add fuel to the fuel tank while the engine is running or while hot.
- Do not refuel the machine indoors.
- Do not store the machine or fuel container where there is an open flame, spark, or pilot light, such as on a water heater or on other appliances.
- Do not fill containers inside a vehicle or on a truck or trailer bed with a plastic liner. Always place containers on the ground, away from your vehicle before filling.
- Remove the equipment from the truck or trailer and refuel it while it is on the ground. If this is not possible, then refuel from a portable container rather than a fuel-dispenser nozzle.

- Do not operate the machine without the entire exhaust system in place and in proper working condition.
- Keep the fuel-dispenser nozzle in contact with the rim of the fuel tank or container opening at all times until fueling is complete. Do not use a nozzle lock-open device.
- If you spill fuel on your clothing, change your clothing immediately. Wipe up any fuel that spills.
- Never overfill the fuel tank. Replace the fuel cap and tighten it securely.
- Store fuel in an approved container and keep it out of the reach of children. Never buy more than a 30-day supply of fuel.
- Do not fill the fuel tank completely full. Add fuel to the fuel tank until the level is 6 to 13 mm (1/4 to 1/2 inch) below the bottom of the filler neck. This empty space in the tank allows fuel to expand.
 - Avoid prolonged breathing of vapors.
 - Keep your face away from the nozzle and fuel tank opening.
 - Avoid contact with skin; wash off spills with soap and water.

Recommended Fuel

- For best results, use only clean, fresh (less than 30 days old), unleaded gasoline with an octane rating of 87 or higher ((R+M)/2 rating method).
- **Ethanol:** Gasoline with up to 10% ethanol (gasohol) or 15% MTBE (methyl tertiary butyl ether) by volume is acceptable. Ethanol and MTBE are not the same. Gasoline with 15% ethanol (E15) by volume is not approved for use. **Never use gasoline that contains more than 10% ethanol by volume**, such as E15 (contains 15% ethanol), E20 (contains 20% ethanol), or E85 (contains up to 85% ethanol). Using unapproved gasoline may cause performance problems and/or engine damage which may not be covered under warranty.
- **Do not** use gasoline containing methanol.
- **Do not** store fuel either in the fuel tank or fuel containers over the winter unless you use a fuel stabilizer.
- **Do not** add oil to gasoline.

Using Stabilizer/Conditioner

Use a fuel stabilizer/conditioner in the machine to provide the following benefits:

- Keeps fuel fresh during storage of 90 days or less (drain the fuel tank when storing the machine for more than 90 days)
- Cleans the engine while it runs
- Eliminates gum-like varnish buildup in the fuel system, which causes hard starting

Important: Do not use fuel additives containing methanol or ethanol.

Add the correct amount of fuel stabilizer/conditioner to the fuel.

Note: A fuel stabilizer/conditioner is most effective when mixed with fresh fuel. To minimize the chance of varnish deposits in the fuel system, use fuel stabilizer at all times.

Filling the Fuel Tank

1. Park the machine on a level surface.
2. Engage the parking brake.
3. Shut off the engine and remove the key.
4. Clean around the fuel-tank cap.
5. Fill the fuel tank until the fuel gauge reads at the full mark (Figure 8).

Note: Do not fill the fuel tank completely full. The empty space in the tank allows the fuel to expand.

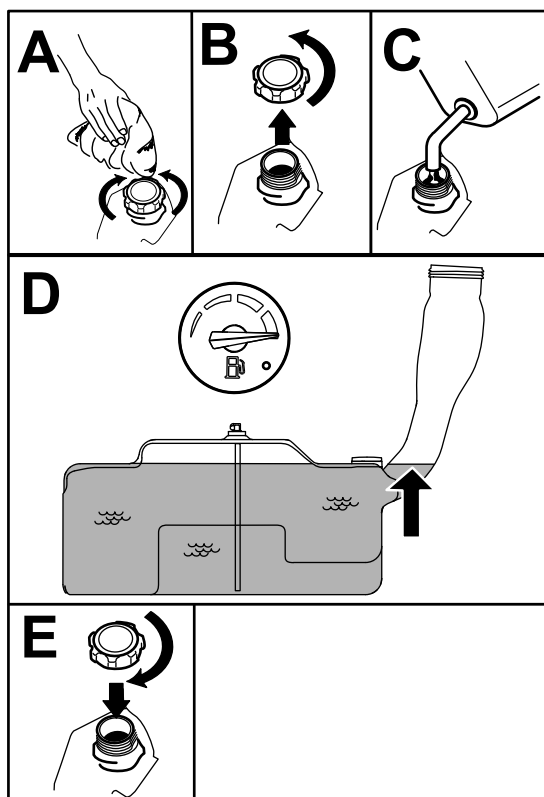

Figure 8

g197123

Breaking in a New Machine

New engines take time to develop full power. Mower decks and drive systems have higher friction when new, placing additional load on the engine. Allow 40 to 50 hours of break-in time for new machines to develop full power and best performance.

Think Safety First

Please read all safety instructions and symbols in the safety section. Knowing this information could help you or bystanders avoid injury.

⚠ DANGER

Operating the machine on wet grass or steep slopes can cause sliding and loss of control.

- Do not operate on slopes greater than 15 degrees.
- Reduce speed and use extreme caution on slopes.
- Do not operate the machine near water.

⚠ DANGER

Wheels dropping over edges can cause rollovers, which may result in serious injury, death, or drowning.

Do not operate the machine near drop-offs.

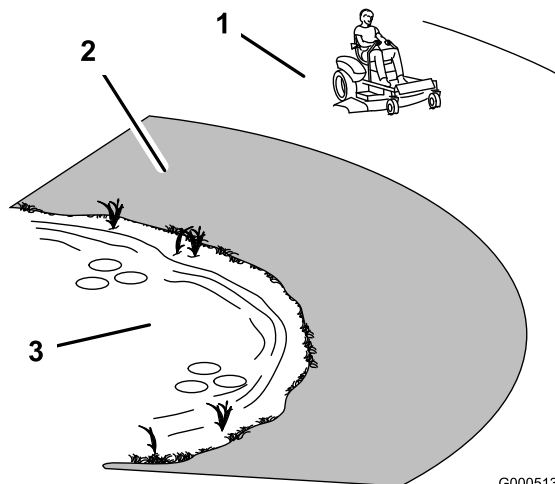

Figure 9

G000513

g000513

Checking the Engine-Oil Level

Before you start the engine and use the machine, check the oil level in the engine crankcase; refer to [Checking the Engine-Oil Level](#) (page 14).

1. Safe Zone—use the machine here on slopes less than 15 degrees or flat areas.
2. Danger Zone—use a walk-behind mower and/or a hand trimmer on slopes greater than 15 degrees and near drop-offs or water.
3. Water

⚠ CAUTION

This machine produces sound levels in excess of 85 dBA at the operator's ear and can cause hearing loss through extended periods of exposure.

Wear hearing protection when operating this machine.

Use protective equipment for your eyes, ears, hands, feet, and head.

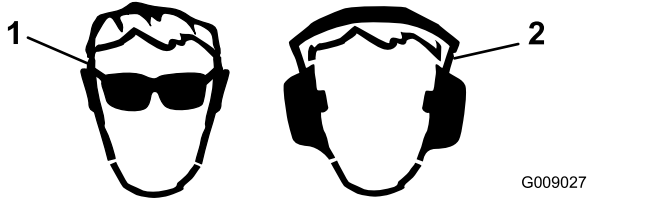

Figure 10

1. Wear eye protection.
2. Wear hearing protection.

Using the Safety-Interlock System

⚠ WARNING

If the safety-interlock switches are disconnected or damaged, the machine could operate unexpectedly, causing personal injury.

- Do not tamper with the interlock switches.
- Check the operation of the interlock switches daily and replace any damaged switches before operating the machine.

Understanding the Safety-Interlock System

The safety-interlock system is designed to prevent the engine from starting unless:

- The blade-control switch (PTO) is disengaged.
- The motion-control levers are in the NEUTRAL-LOCK position.
- The parking brake is engaged.

The safety-interlock system also is designed to shut off the engine whenever the control levers are out of the NEUTRAL-LOCK position and you rise from the seat.

Testing the Safety-Interlock System

Service Interval: Before each use or daily

Test the safety-interlock system before you use the machine each time. If the safety system does not operate as described below, have an Authorized Service Dealer repair the safety system immediately.

1. Sit on the seat, engage the parking brake, and move the blade-control switch (PTO) to the ON position. Try starting the engine; the engine should not crank.
2. Sit on the seat, engage the parking brake, and move the blade-control switch (PTO) to the OFF position. Move either motion-control lever (out of the NEUTRAL-LOCK position). Try starting the engine; the engine should not crank. Repeat for other control lever.
3. Sit on the seat, engage the parking brake, move the blade-control switch (PTO) to the OFF position, and move the motion-control levers to the NEUTRAL-LOCK position. Start the engine. While the engine is running, release the parking brake, engage the blade-control switch (PTO), and rise slightly from the seat; the engine should shut off.
4. Sit on the seat, engage the parking brake, move the blade-control switch (PTO) to the OFF position, and move the motion-control levers to NEUTRAL-LOCK position. Start the engine. While the engine is running, center either motion-control lever and move it forward or reverse; the engine should shut off. Repeat for other motion-control lever.
5. Sit on the seat, disengage the parking brake, move the blade-control switch (PTO) to the OFF position, and move the motion-control levers to NEUTRAL-LOCK position. Try starting the engine; the engine should not crank.

Positioning the Seat

The seat moves forward and backward. Position the seat where you have the best control of the machine and are most comfortable.

To adjust, move the lever sideways to unlock the seat (Figure 11).

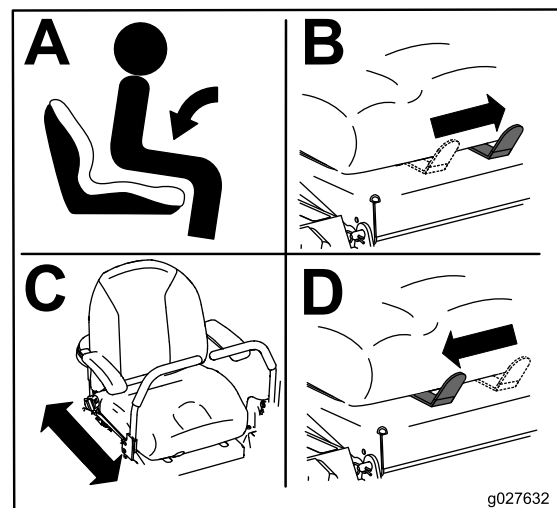

Figure 11

Adjusting the MyRide™ Suspension System

The MyRide™ suspension system adjusts to provide a smooth and comfortable ride. Adjusting the rear 2-shock assemblies is the easiest and quickest adjustment for changing the suspension system. Position the suspension system where you are most comfortable.

Adjusting the Rear-Shock Assemblies

The slots for the rear-shock assemblies have detent positions for reference. You can position the rear-shock assemblies anywhere in the slot, not just in the detent positions.

The following graphic shows the position for a soft or firm ride and the different detent positions (Figure 12).

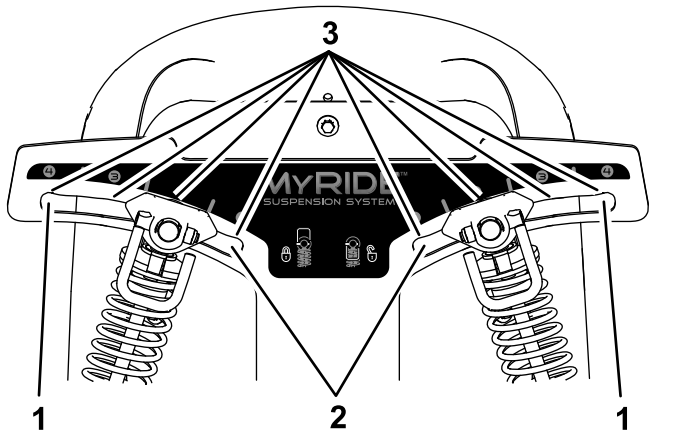
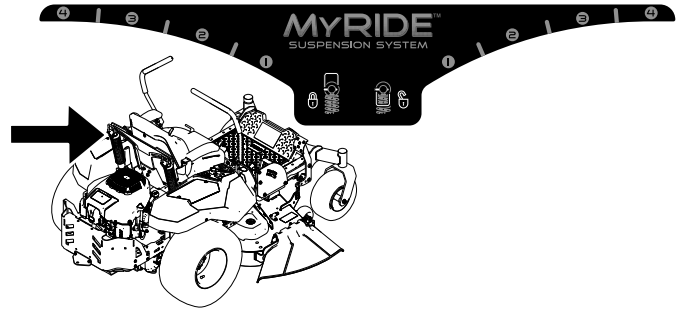

Figure 12

- 1. Firmest position
- 2. Softest position
- 3. Detents in the slots

Note: Ensure that the left and right rear-shock assemblies are always adjusted to the same positions.

Adjust the rear-shock assemblies (Figure 13).



g195746

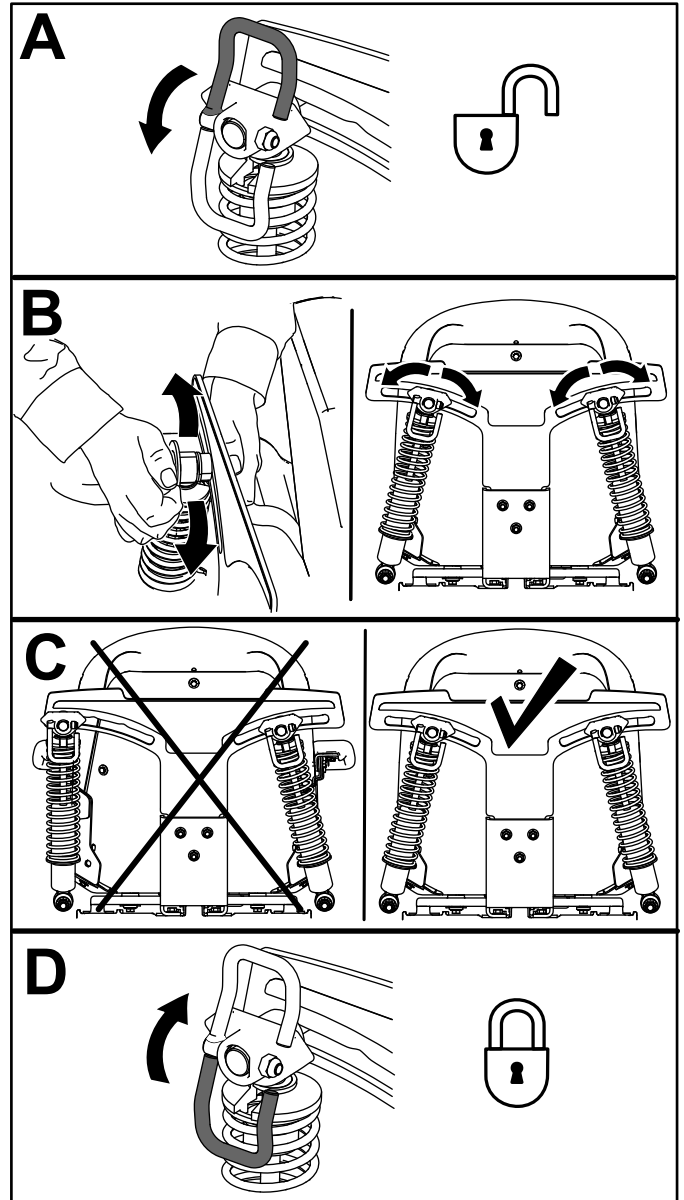

g195745

Figure 13

Adjusting the Motion-Control Levers

Adjusting the Height

You can adjust the motion-control levers higher or lower for maximum comfort (Figure 14).

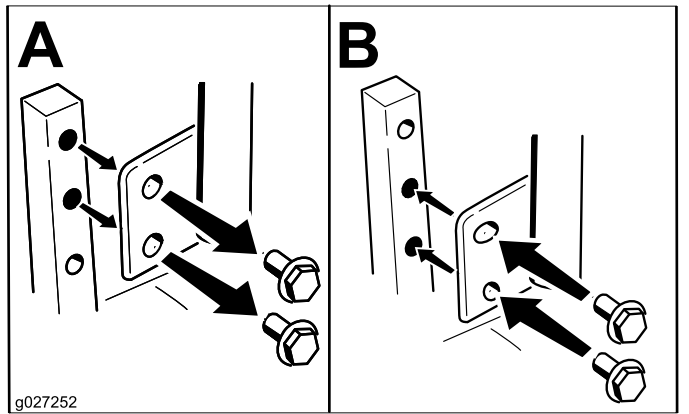

Figure 14

Adjusting the Tilt

You can adjust the motion-control levers forward or rearward for your comfort.

1. Loosen the upper bolt holding the control lever to the control-arm shaft.
2. Loosen the lower bolt just enough to pivot the control lever forward or rearward (Figure 14).
3. Tighten both bolts to secure the control lever in the new position.
4. Repeat the adjustment for the other control lever.

During Operation

During Operation Safety

General Safety

- The owner/operator can prevent and is responsible for accidents that may cause personal injury or property damage.
- Wear appropriate clothing, including eye protection; slip-resistant, substantial footwear; and hearing protection. Tie back long hair and do not wear jewelry.
- Do not operate the machine while ill, tired, or under the influence of alcohol or drugs.
- Never carry passengers on the machine and keep bystanders and pets away from the machine during operation.
- Operate the machine only in good visibility to avoid holes or hidden hazards.
- Avoid mowing on wet grass. Reduced traction could cause the machine to slide.
- Ensure that all drives are in neutral, the parking brake is engaged, and you are in the operating position before you start the engine.
- Keep your hands and feet away from the cutting units. Keep clear of the discharge opening at all times.
- Look behind and down before backing up to be sure of a clear path.
- Use care when approaching blind corners, shrubs, trees, or other objects that may obscure your vision.
- Do not mow near drop-offs, ditches, or embankments. The machine could suddenly roll over if a wheel goes over the edge or if the edge gives way.
- Stop the blades whenever you are not mowing.
- Stop the machine and inspect the blades after striking an object or if there is an abnormal vibration in the machine. Make all necessary repairs before resuming operation.
- Slow down and use caution when making turns and crossing roads and sidewalks with the machine. Always yield the right-of-way.
- Disengage the drive to the cutting unit and shut off the engine before adjusting the height of cut (unless you can adjust it from the operating position).
- Never run an engine in an area where exhaust gases are enclosed.
- Never leave a running machine unattended.
- Before leaving the operating position (including to empty the catchers or to unclog the chute), do the following:
 - Stop the machine on level ground.
 - Disengage the power take-off and lower the attachments.
 - Engage the parking brake.
 - Shut off the engine and remove the key.

– Wait for all moving parts to stop.

- Do not operate the machine when there is the risk of lightning.
- Do not use the machine as a towing vehicle.
- Do not change the governor speed or overspeed the engine.
- Use accessories and attachments approved by Toro only.

Slope Safety

- Slow down the machine and use extra care on hillsides. Travel up and down on hillsides. Turf conditions can affect the stability of the machine.
- Avoid turning the machine on slopes. If you must turn the machine, turn it slowly and gradually downhill, if possible.
- Do not turn the machine sharply. Use care when reversing the machine.
- Use extra care while operating the machine with attachments; they can affect the stability of the machine.
- A 2-post ROPS (Rollover Protection System) is available for the machine as an accessory. A ROPS is recommended if you will be mowing next to drop-offs, near water, or on steep banks which could result in a rollover. Contact an Authorized Service Dealer for more details.

Operating the Parking Brake

Always engage the parking brake when you stop the machine or leave it unattended.

Engaging the Parking Brake

⚠ WARNING

The parking brake may not hold the machine parked on a slope and could cause personal injury or property damage.

Do not park on slopes unless the wheels are chocked or blocked.

To engage the parking brake, pull up the parking brake until it latches into the detent slot (Figure 15).

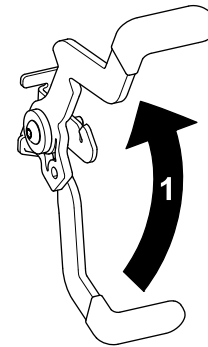

Figure 15

g188778

1. Pull up the parking brake.

Disengaging the Parking Brake

To disengage the parking brake, pull the lever out of the detent slot and toward you, then push it down (Figure 16).

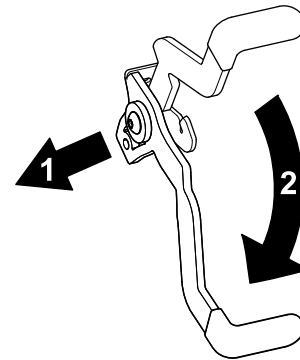

Figure 16

g188777

1. Push the parking brake out of the detent slot and toward you.
2. Push the parking brake down.

Operating the Mower Blade-Control Switch (PTO)

The blade-control switch (PTO) starts and stops the mower blades and any powered attachments.

Engaging the Blade-Control Switch (PTO)

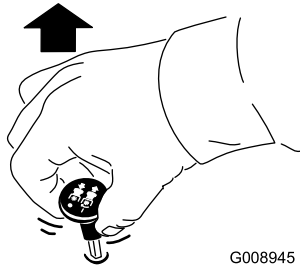

G008945

g008945

Figure 17

Note: Always engage the blades with the throttle in the FAST position (Figure 18).

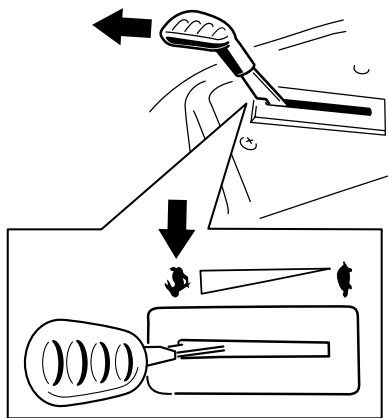

g187516

Figure 18

Disengaging the Blade-Control Switch (PTO)

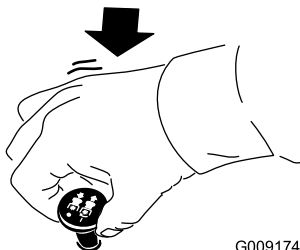

G009174

g009174

Figure 19

Operating the Throttle

You can move the throttle control between the FAST and SLOW positions (Figure 20).

Always use the FAST position when turning on the mower deck with the blade-control switch (PTO).

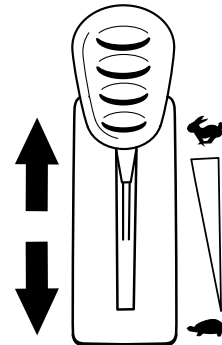

g187517

Figure 20

Operating the Choke

Use the choke to start a cold engine.

1. If the engine is cold, use the choke to start the engine.
2. Pull up on the choke knob to engage the choke before using the ignition switch (Figure 21).
3. Push down on the choke to disengage the choke after the engine has started (Figure 21).

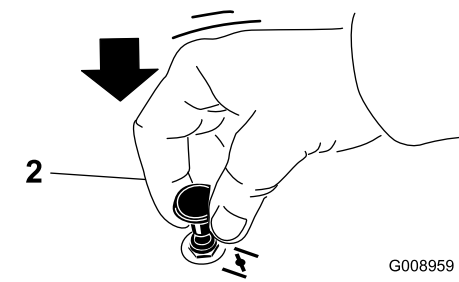
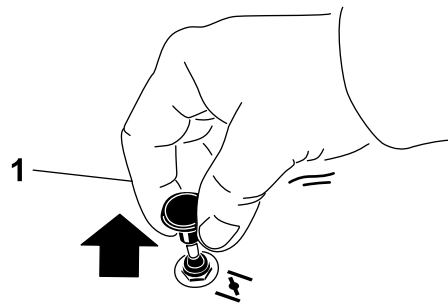

G008959

g008959

Figure 21

1. ON position

2. OFF position

Operating the Ignition Switch

1. Turn the ignition key to the START position (Figure 22).

Note: When the engine starts, release the key.

Important: Do not engage starter for more than 5 seconds at a time. If the engine fails to start, allow a 15 second cool-down period between attempts. Failure to follow these instructions can burn out the starter motor.

Note: You may need multiple attempts to start the engine when you start it the first time after the fuel system has been without fuel completely.

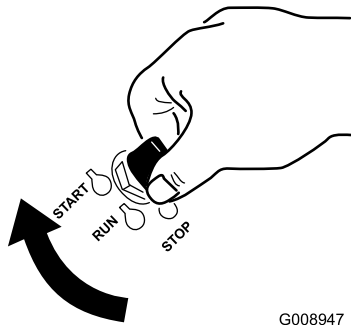

Figure 22

G008947

g008947

2. Turn the ignition key to shut off the engine.

Starting and Shutting Off the Engine

Starting the Engine

Note: A warm or hot engine may not require choking.

Important: Do not engage the starter for more than 5 seconds at a time. Engaging the starter motor for more than 5 seconds can damage the starter motor. If the engine fails to start, wait 10 seconds before operating the engine starter again.

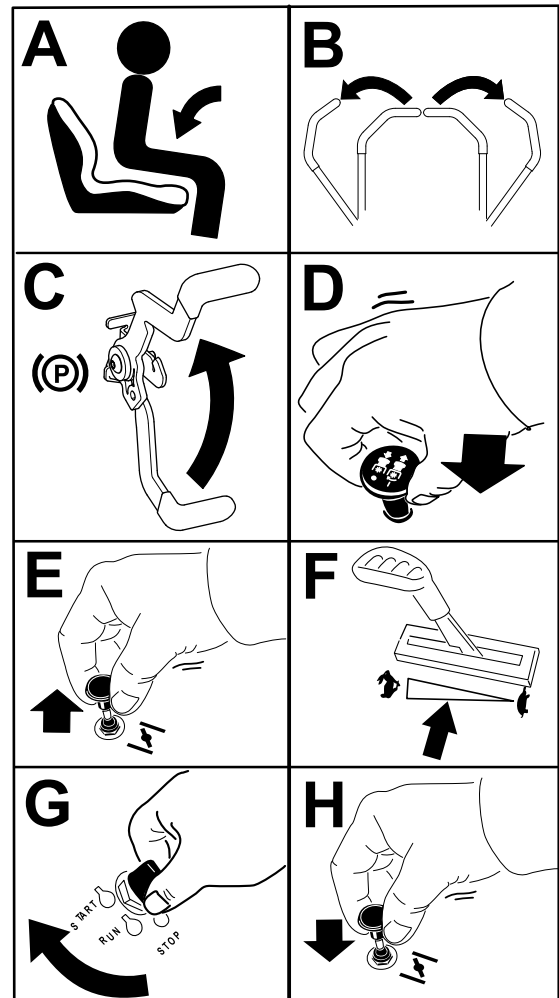

Figure 23

g189354

Shutting Off the Engine

1. Disengage the blades by moving the blade-control switch to the OFF position (Figure 21).
2. Move the throttle lever to the FAST position.
3. Turn the ignition key to the OFF position and remove the key.

Using the Motion-Control Levers

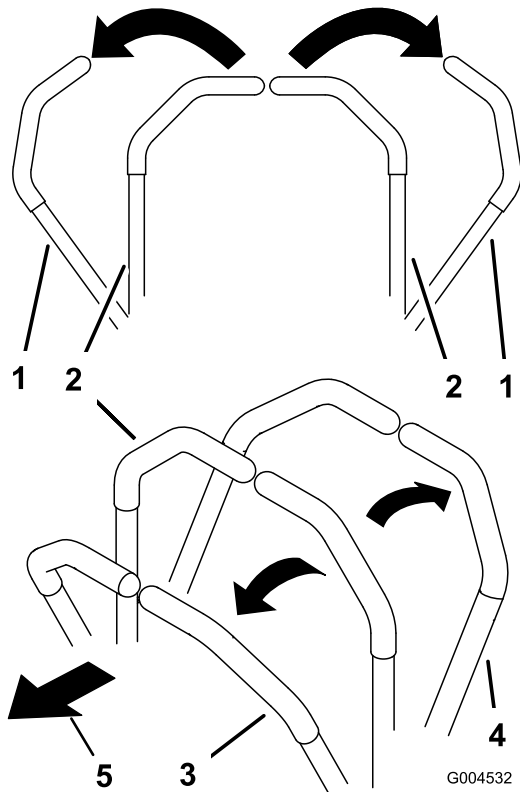

Figure 24

- | | |
|-----------------------------------------------|---------------------|
| 1. Motion-control lever—NEUTRAL-LOCK position | 4. Backward |
| 2. Center, unlocked position | 5. Front of machine |
| 3. Forward | |

Driving Forward

Note: The engine stops when you move the traction-control with the parking brake engaged.

To stop, pull the motion-control levers to the NEUTRAL position.

1. Disengage the parking brake; refer to [Disengaging the Parking Brake \(page 18\)](#).
2. Move the levers to the center, unlocked position.
3. To go forward, slowly push the motion-control levers forward ([Figure 25](#)).

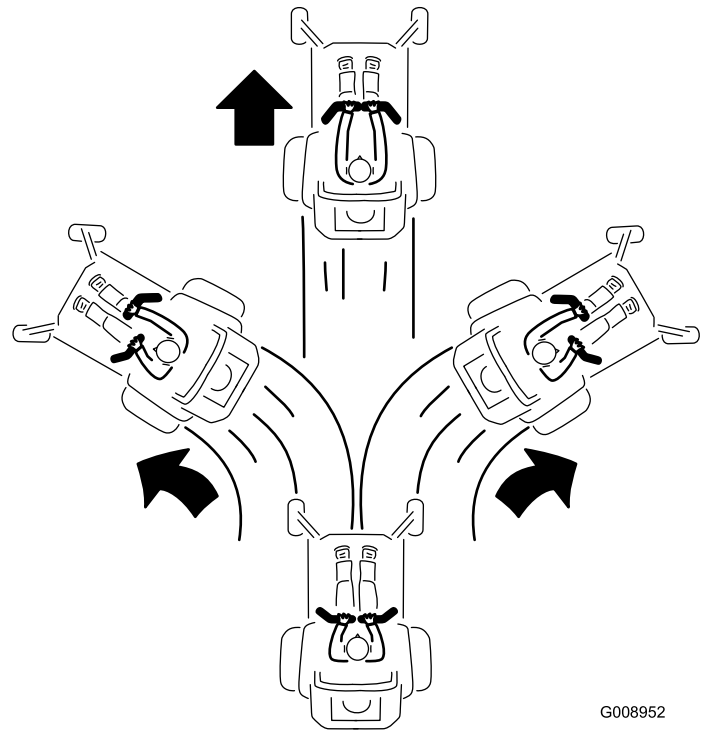

Figure 25

Driving the Machine

The drive wheels turn independently, powered by hydraulic motors on each axle. You can turn 1 side in reverse while you turn the other forward, causing the machine to spin rather than turn. This greatly improves the machine maneuverability but may require sometime for you to adapt to how it moves.

The throttle control regulates the engine speed as measured in rpm (revolutions per minute). Place the throttle control in the FAST position for best performance. Always operate in the full throttle position when mowing.

⚠ CAUTION

The machine can spin very rapidly, which may cause you to lose control of machine, resulting in personal injury or damage to machine.

- Use caution when making turns.
- Slow the machine down before making sharp turns.

Driving Backward

1. Move the levers to the center, unlocked position.
2. To go backward, slowly pull the motion-control levers rearward (Figure 26).

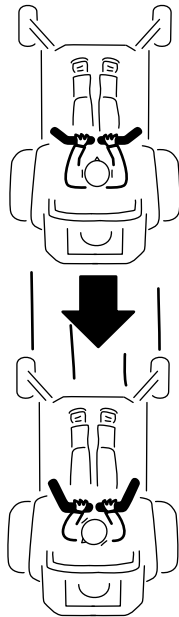

Figure 26

G008953

g008953

Using the Smart Speed™ Control System

The Smart Speed™ Control-System lever, located to the right of the operating position (Figure 27), gives you a choice to drive the machine at 3 ground speed ranges—trim, tow, and mow.

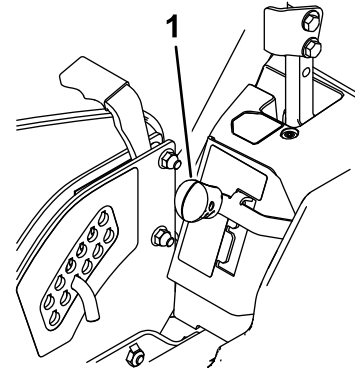

Figure 27

g197125

1. Smart-speed lever

To change speeds, do the following:

1. Move the motion-control levers to neutral and outward to the NEUTRAL-LOCK position.
2. Disengage the blade-control switch.
3. Adjust the lever to the desired position.

The following are only recommendations for use. Adjustments vary by grass type, moisture content, and the height of the grass.

Suggested uses:	Trim	Tow	Mow
Parking	X		
Heavy, wet grass	X		
Training	X		
Bagging		X	
Mulching		X	
Normal mowing			X
Transport			X

Trim

This is the lowest speed. The suggested uses for this speed are as follows:

- Parking
- Heavy, wet grass mowing conditions
- Training

Tow

This is the medium speed. The suggested uses for this speed are as follows:

- Bagging
- Mulching

Mow

This is the fastest speed. The suggested uses for this speed are as follows:

- Normal mowing
- Transporting the machine

Stopping the Machine

To stop the machine, move the traction-control levers to neutral, and then move them to the locked position, disengage the blade-control switch (PTO), and turn the ignition key to the OFF position.

Engage the parking brake when you leave the machine; refer to [Engaging the Parking Brake \(page 18\)](#). Remember to remove the key from the ignition switch.

⚠ CAUTION

Children or bystanders may be injured if they move or attempt to operate the machine while it is unattended.

Always remove the ignition key and engage the parking brake when leaving the machine unattended, even if just for a few minutes.

Using the Side Discharge

The mower has a hinged grass deflector that disperses clippings to the side and down toward the turf.

⚠ DANGER

Without a grass deflector, discharge cover, or a complete grass-catcher assembly mounted in place, you and others are exposed to blade contact and thrown debris. Contact with rotating mower blade(s) and thrown debris will cause injury or death.

- Never remove the grass deflector from the mower because the grass deflector routes material down toward the turf. If the grass deflector is ever damaged, replace it immediately.
- Never put your hands or feet under the mower.
- Never try to clear the discharge area or mower blades unless you move the blade-control switch (PTO) to the OFF position, rotate the ignition key to the OFF position, and remove the key.
- Make sure that the grass deflector is in the down position.

Adjusting the Height of Cut

The machine is equipped with a foot pedal deck-lift system. You can use the foot pedal to lift the deck briefly to avoid obstacles or lock the deck in the highest height of cut or transport position. You can use the height-of-cut lever with the foot pedal to lock the deck in a specific cutting height.

Using the Foot Pedal Deck-Lift System

- Press the deck-lift pedal down to raise the deck; continue to press the pedal until the deck locks in the transport position ([Figure 28](#)).
- Push on the deck-lift pedal with your foot and pull the transport lock handle rearward to disengage the transport lock ([Figure 28](#)).

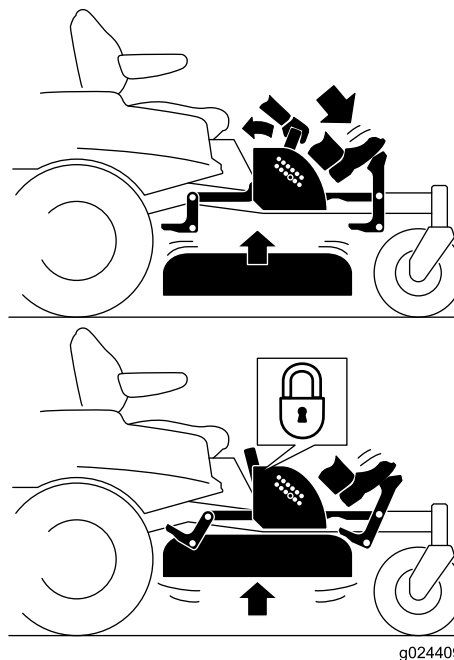

Figure 28
Transport Lock Position

Adjusting the Height of Cut

You can adjust the height of cut from 38 to 114 mm (1-1/2 to 4-1/2 inches) in 6 mm (1/4 inch) increments by relocating the height-of-cut pin into different hole locations.

1. Push on the deck-lift pedal with your foot and raise the mower deck to the transport-lock position (also the 114 mm (4-1/2 inches) cutting height position) as shown in [Figure 29](#).
2. To adjust, remove the pin from the height-of-cut bracket ([Figure 29](#)).
3. Select a hole in the height-of-cut system corresponding to the desired height of cut and insert the pin ([Figure 29](#)).

4. Push on the deck-lift pedal with your foot and pull the handle rearward to disengage the transport lock (Figure 28).
5. Lower the deck slowly until the lever makes contact with the pin.

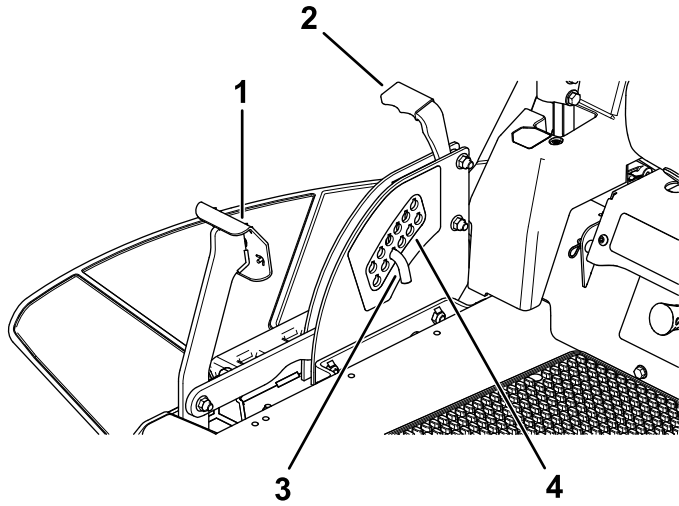

Figure 29

- | | |
|--------------------|----------------------------|
| 1. Deck-lift pedal | 3. Pin |
| 2. Handle | 4. Height-of-cut positions |

g188850

Adjusting the Anti-Scalp Rollers

Whenever you change the height-of-cut, it is recommended to adjust the height of the anti-scalp rollers.

1. Disengage the blade-control switch (PTO), move the motion-control levers to the NEUTRAL-LOCK position, and engage the parking brake.
2. Shut off the engine, remove the key, and wait for all moving parts to stop before leaving the operating position.
3. Adjust the anti-scalp rollers as shown in Figure 30.

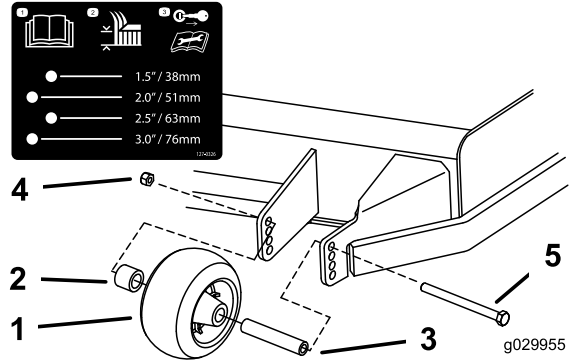

Figure 30

- | | |
|----------------------|---------------|
| 1. Anti-scalp roller | 4. Flange nut |
| 2. Spacer | 5. Bolt |
| 3. Bushing | |

g029955

g029955

Using Attachments and Accessories

Use only Toro approved attachments and accessories.

If you attach a bucket to the engine guard, use a nylon strap to secure it.

Important: The bucket weight impacts the stability of the machine. If you are carrying more than the weight listed in the table below in a bucket attached to the engine guard, you must equip your machine with the Bucket-Support Kit.

Contact your authorized Toro service dealer.

Model	Maximum weight per bucket without the Bucket-Support Kit
48-inch deck	1.1 kg (2.5 lb)
54-inch deck	1.1 kg (2.5 lb)
60-inch deck	4.5 kg (10 lb)

Operating Tips

Using the Fast Throttle Setting

For best mowing and maximum air circulation, operate the engine at the FAST position. Air is required to thoroughly cut grass clippings, so do not set the height-of-cut so low as to totally surround the mower in uncut grass. Always try to have 1 side of the mower free from uncut grass, which allows air to be drawn into the mower.

Cutting a Lawn for the First Time

Cut grass slightly longer than normal to ensure that the cutting height of the mower does not scalp any uneven ground. However, the cutting height used in the past is generally the best one to use. When cutting grass longer than 15 cm (6 inches) tall, you may want to cut the lawn twice to ensure an acceptable quality of cut.

Cutting a Third of the Grass Blade

It is best to cut only about a third of the grass blade. Cutting more than that is not recommended unless grass is sparse, or it is late fall when grass grows more slowly.

Alternating the Mowing Direction

Alternate the mowing direction to keep the grass standing straight. This also helps disperse clippings which enhances decomposition and fertilization.

Mowing at Correct Intervals

Grass grows at different rates at different times of the year. To maintain the same cutting height, mow more often in early spring. As the grass growth rate slows in mid summer, mow less frequently. If you cannot mow for an extended period, first mow at a high cutting height, then mow again 2 days later at a lower height setting.

Using a Slower Cutting Speed

To improve cut quality, use a slower ground speed in certain conditions.

Avoiding Cutting Too Low

When mowing uneven turf, raise the cutting height to avoid scalping the turf.

Stopping the Machine

If you must stop the forward motion of the machine while mowing, a clump of grass clippings may drop onto your lawn. To avoid this, move onto a previously cut area with the blades engaged or you can disengage the mower deck while moving forward.

Keeping the Underside of the Mower Clean

Clean clippings and dirt from the underside of the mower after each use. If grass and dirt build up inside the mower, cutting quality will eventually become unsatisfactory.

Maintaining the Blade(s)

Maintain a sharp blade throughout the cutting season because a sharp blade cuts cleanly without tearing or shredding the grass blades. Tearing and shredding turns grass brown at the edges, which slows growth and increases the chance of disease. Check the mower blades after each use for sharpness, and for any wear or damage. File down any nicks and sharpen the blades as necessary. If a blade is damaged or worn, replace it immediately with a genuine Toro replacement blade.

After Operation

After Operation Safety

General Safety

- Clean grass and debris from the cutting units, mufflers, and engine compartment to help prevent fires. Clean up oil or fuel spills.
- Shut off the fuel before storing or transporting the machine.
- Disengage the drive to the attachment whenever you are transporting or not using the machine.
- Use full-width ramps for loading the machine into a trailer or truck.
- Tie the machine down securely using straps, chains, cable, or ropes. Both front and rear straps should be directed down and outward from the machine.
- Allow the engine to cool before storing the machine in any enclosure.
- Never store the machine or fuel container where there is an open flame, spark, or pilot light, such as on a water heater or on other appliances.

Pushing the Machine by Hand

Important: Always push the machine by hand. Do not tow the machine, because damage may occur.

This machine has an electric-brake mechanism, and to push the machine, the ignition key must be in the RUN position. The battery needs to be charged and functioning for the electric brake to be disengaged.

Pushing the Machine

1. Park the machine on a level surface, and disengage the blade-control switch.
2. Engage the parking brake, shut off the engine, and wait for all moving parts to stop before leaving the operating position.
3. Locate the bypass levers on the frame on both sides of the engine.
4. Move the bypass levers forward through the key hole and down to lock them in place (Figure 31).

Note: Do this for each lever.

5. Disengage the parking brake.

Note: Do not start the machine.

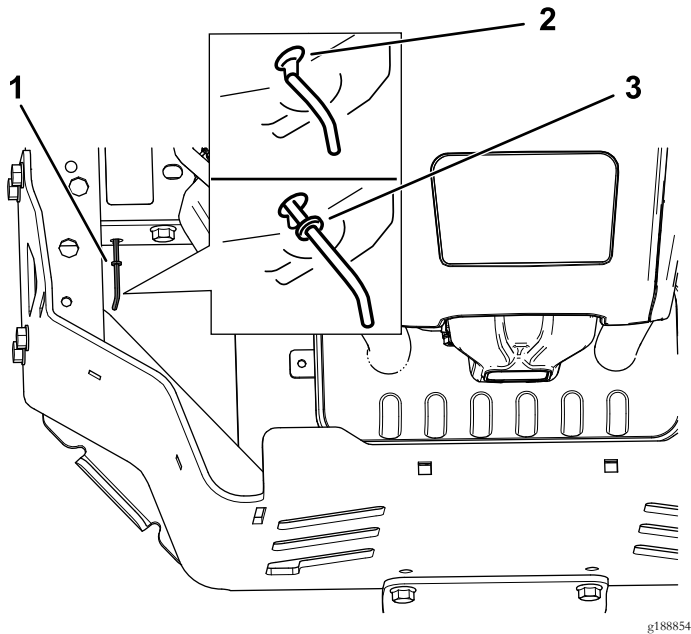

Figure 31

1. Bypass lever
2. Lever position for pushing the machine
3. Lever position for operating the machine

Operating the Machine

Move the bypass levers rearward through the keyhole and down to lock them in place as shown in Figure 31.

Note: Do this for each lever.

Transporting the Machine

Use a heavy-duty trailer or truck to transport the machine. Ensure that the trailer or truck has all necessary brakes, lighting, and marking as required by law. Please carefully read all the safety instructions. Knowing this information could help you, your family, pets, or bystanders avoid injury.

⚠ WARNING

Driving on the street or roadway without turn signals, lights, reflective markings, or a slow-moving-vehicle emblem is dangerous and can lead to accidents, causing personal injury.

Do not drive the machine on a public street or roadway.

1. If you are using a trailer, connect it to the towing vehicle and connect the safety chains.
2. If applicable, connect the trailer brakes.
3. Load the machine onto the trailer or truck.
4. Shut off the engine, remove the key, set the brake, and close the fuel valve.
5. Tie down the machine near the front caster wheels and the rear bumper (Figure 32).

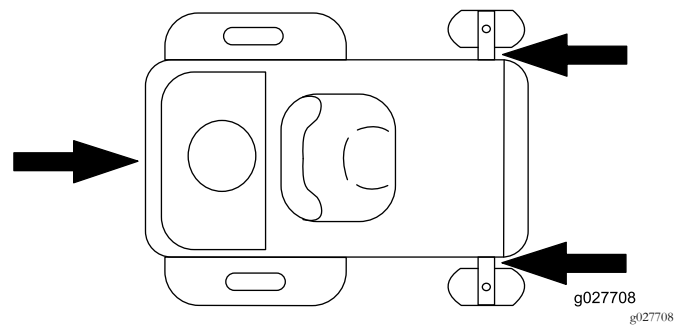

Figure 32

Loading the Machine

Use extreme caution when loading or unloading machines onto a trailer or a truck. Use a full-width ramp that is wider than the machine for this procedure. Back the machine up the ramp and drive it forward down the ramp (Figure 33).

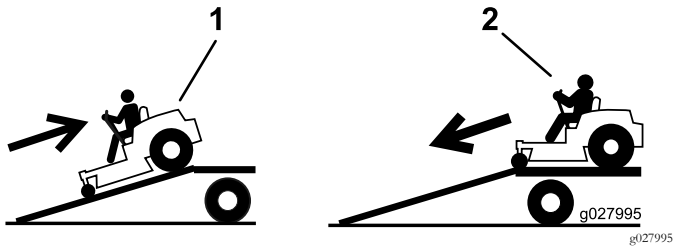

Figure 33

1. Back the machine up the ramp.
2. Drive the machine forward down the ramp.

Important: Do not use narrow individual ramps for each side of the machine.

⚠ WARNING

Loading a machine onto a trailer or truck increases the possibility of tip-over and could cause serious injury or death (Figure 34).

- Use extreme caution when operating a machine on a ramp.
- Use only a full-width ramp; do not use individual ramps for each side of the machine.
- Do not exceed a 15-degree angle between the ramp and the ground or between the ramp and the trailer or truck.
- Ensure that the length of ramp is at least 4 times as long as the height of the trailer or truck bed to the ground. This ensures that the ramp angle does not exceed 15 degrees on flat ground.
- Back up ramps and drive forward down ramps.
- Avoid sudden acceleration or deceleration while driving the machine on a ramp as this could cause a loss of control or a tip-over situation.

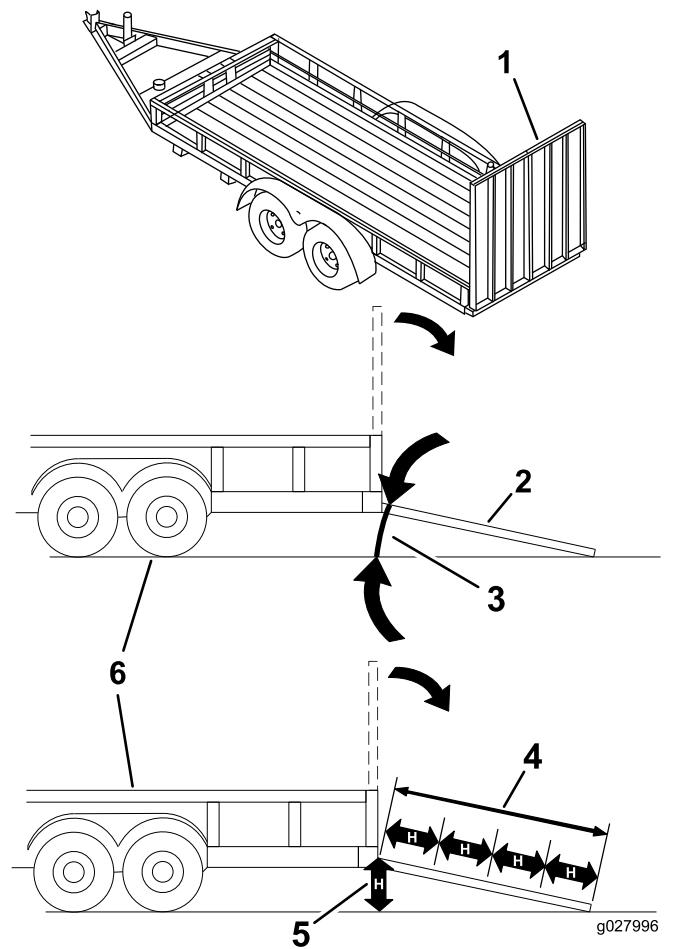

Figure 34

1. Full-width ramp in stowed position
2. Side view of full-width ramp in loading position
3. Not greater than 15 degrees
4. Ramp is at least 4 times as long as the height of the trailer or truck bed to the ground
5. H=height of the trailer or truck bed to the ground
6. Trailer

Maintenance

Note: Determine the left and right sides of the machine from the normal operating position.

Recommended Maintenance Schedule(s)

Maintenance Service Interval	Maintenance Procedure
After the first 5 hours	<ul style="list-style-type: none">• Change the engine oil.
Before each use or daily	<ul style="list-style-type: none">• Check the safety-interlock system.• Check the air cleaner for dirty, loose, or damaged parts.• Check the engine-oil level.• Clean the air intake screen.• Inspect the blades.• Inspect the grass deflector for damage.
After each use	<ul style="list-style-type: none">• Clean the mower-deck housing.
Every 25 hours	<ul style="list-style-type: none">• Clean the air-cleaner foam element (more often in dusty, dirty conditions).• Check tire pressure.• Check the belts for wear or cracks.
Every 100 hours	<ul style="list-style-type: none">• Replace the air-cleaner foam element (more often in dusty, dirty conditions).• Service the air-cleaner paper element (more often in dusty, dirty conditions).• Change the engine oil (more often in dusty, dirty conditions).• Change the oil filter (more often in dusty, dirty conditions).• Check the spark plug(s).• Check the in-line fuel filter.
Every 200 hours	<ul style="list-style-type: none">• Replace the air-cleaner paper element (more often in dusty, dirty conditions).• Replace the spark plug(s).• Replace the in-line fuel filter.
Before storage	<ul style="list-style-type: none">• Charge the battery and disconnect the battery cables.• Perform all maintenance procedures listed above before storage.• Paint any chipped surfaces.

▲ CAUTION

If you leave the key in the ignition switch, someone could accidentally start the engine and seriously injure you or other bystanders.

Remove the key from the ignition before you perform any maintenance.

Pre-Maintenance Procedures

Maintenance and Storage Safety

- Before repairing the machine do the following:
 - Disengage the drives.
 - Engage the parking brake.
 - Shut off the engine and remove the key.
 - Disconnect the spark-plug wire.
- Park the machine on a level surface.
- Clean grass and debris from the cutting unit, drives, mufflers, and engine to help prevent fires.
- Clean up oil or fuel spills.
- Let the engine cool before storing the machine.
- Do not store the machine or fuel near flames or drain the fuel indoors.
- Do not allow untrained personnel to service the machine.
- Use jack stands to support the machine and/or components when required.
- Carefully release pressure from components with stored energy.
- Disconnect the battery or remove the spark-plug wire before making any repairs. Disconnect the negative terminal first and the positive terminal last. Connect the positive terminal first and negative last.
- Use care when checking the blades. Wrap the blade(s) or wear thickly padded gloves, and use caution when servicing them. Only replace blades; do not straighten or weld them.
- Keep your hands and feet away from moving parts. If possible, do not make adjustments with the engine running.
- Keep all parts in good working condition and all hardware tightened, especially the blade-attachment bolts. Replace all worn or damaged decals.
- Never interfere with the intended function of a safety device or reduce the protection provided by a safety device. Check their proper operation regularly.
- To ensure optimum performance and continued safety certification of the machine, use only genuine Toro replacement parts and accessories. Replacement parts and accessories made by other manufacturers could be dangerous, and such use could void the product warranty.
- Check the parking brake operation frequently. Adjust and service as required.

Engine Maintenance

⚠ WARNING

Contact with hot surfaces may cause personal injury.

Keep your hands, feet, face, clothing, and other body parts away from the muffler and other hot surfaces.

Engine Safety

Shut off the engine before checking the oil or adding oil to the crankcase.

Servicing the Air Cleaner

Service Interval: Before each use or daily

Note: Service the air cleaner more frequently (every few hours) if operating conditions are extremely dusty or sandy.

Removing the Elements

1. Park the machine on a level surface and disengage the blade-control switch (PTO).
2. Engage the parking brake, shut off the engine, remove the key, and wait for all moving parts to stop before leaving the operating position.
3. Clean around the air-cleaner cover to prevent dirt from getting into the engine and causing damage.
4. Lift the cover and rotate the air-cleaner assembly out of the engine (Figure 35).

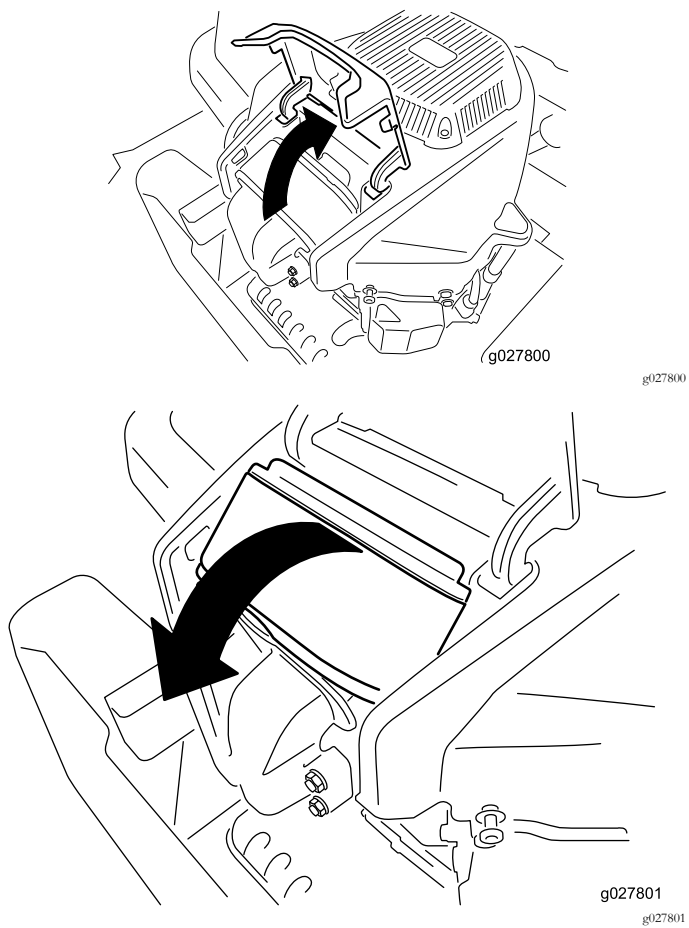

Figure 35

5. Remove the foam element from the paper element (Figure 36).

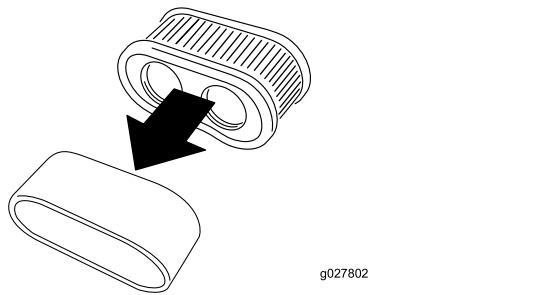

Figure 36

Servicing the Foam Element

Service Interval: Every 25 hours/Monthly (whichever comes first)—Clean the air-cleaner foam element (more often in dusty, dirty conditions).

Every 100 hours/Yearly (whichever comes first)—Replace the air-cleaner foam element (more often in dusty, dirty conditions).

Wash the foam element with water and replace the foam element if it is damaged.

Servicing the Paper Element

Service Interval: Every 100 hours/Yearly (whichever comes first)—Service the air-cleaner paper element (more often in dusty, dirty conditions).

Every 200 hours/Every 2 years (whichever comes first)—Replace the air-cleaner paper element (more often in dusty, dirty conditions).

1. Lightly tap the element on a flat surface to remove dust and dirt.
2. Inspect the element for tears, an oily film, and damage to the seal.

Important: Do not clean the paper element with pressurized air or liquids, such as solvent, gasoline, or kerosene. Replace the paper element if it is damaged or cannot be cleaned thoroughly.

Servicing the Engine Oil

Oil Type: Detergent oil (API service SF, SG, SH, SJ, or SL)

Crankcase Capacity: with filter—2.4 L (2.5 US qt)

Viscosity: See the table below.

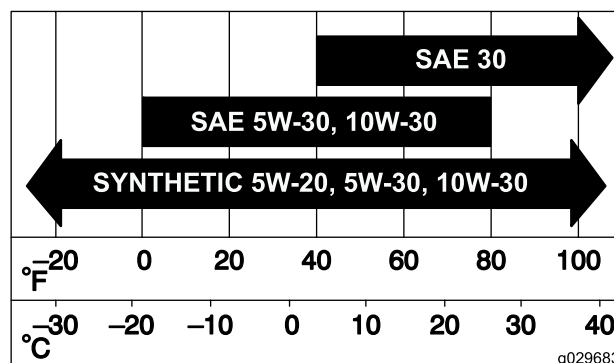

Figure 37

Checking the Engine-Oil Level

Service Interval: Before each use or daily

Note: Check the oil when the engine is cold.

▲ WARNING

Contact with hot surfaces may cause personal injury.

Keep your hands, feet, face, clothing, and other body parts away from the muffler and other hot surfaces.

Important: If you overfill or underfill the engine crankcase with oil and run the engine, you may damage the engine.

1. Park the machine on a level surface, disengage the blade-control switch, shut off the engine, engage parking brake, and remove the key.
2. Make sure that the engine is shut off, level, and is cool, so that the oil has had time to drain into the sump.
3. To keep dirt, grass clippings, etc., out of the engine, clean the area around the oil-fill cap and dipstick before removing it (Figure 38).
4. Shut off the engine, remove the key, and wait for all moving parts to stop before leaving the operating position.

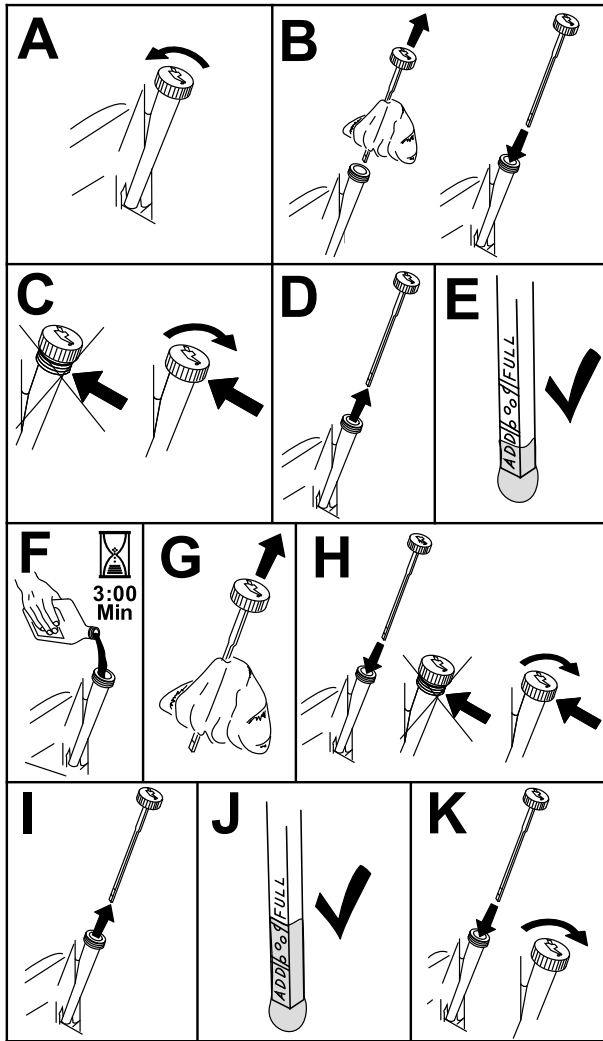

Figure 38

g193541

Changing the Engine Oil and Oil Filter

Service Interval: After the first 5 hours/After the first month (whichever comes first)—Change the engine oil.

Every 100 hours/Yearly (whichever comes first)—Change the engine oil (more often in dusty, dirty conditions).

Every 100 hours/Yearly (whichever comes first)—Change the oil filter (more often in dusty, dirty conditions).

Note: Change the engine-oil filter more frequently when operating conditions are extremely dusty or sandy.

Note: Dispose of the used oil at a recycling center.

1. Park the machine on a level surface to ensure that the oil drains completely.
2. Disengage the PTO and ensure that the parking brake is engaged.
3. Shut off the engine, remove the key, and wait for all moving parts to stop before leaving the operating position.
4. Drain the engine oil.

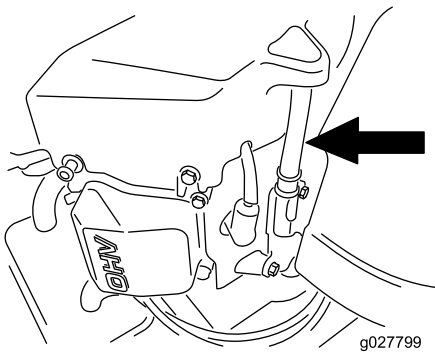

g027799

g027799

5. Change the engine-oil filter (Figure 40).

Note: Ensure that the oil-filter gasket touches the engine and then turn the filter an extra 3/4 turn.

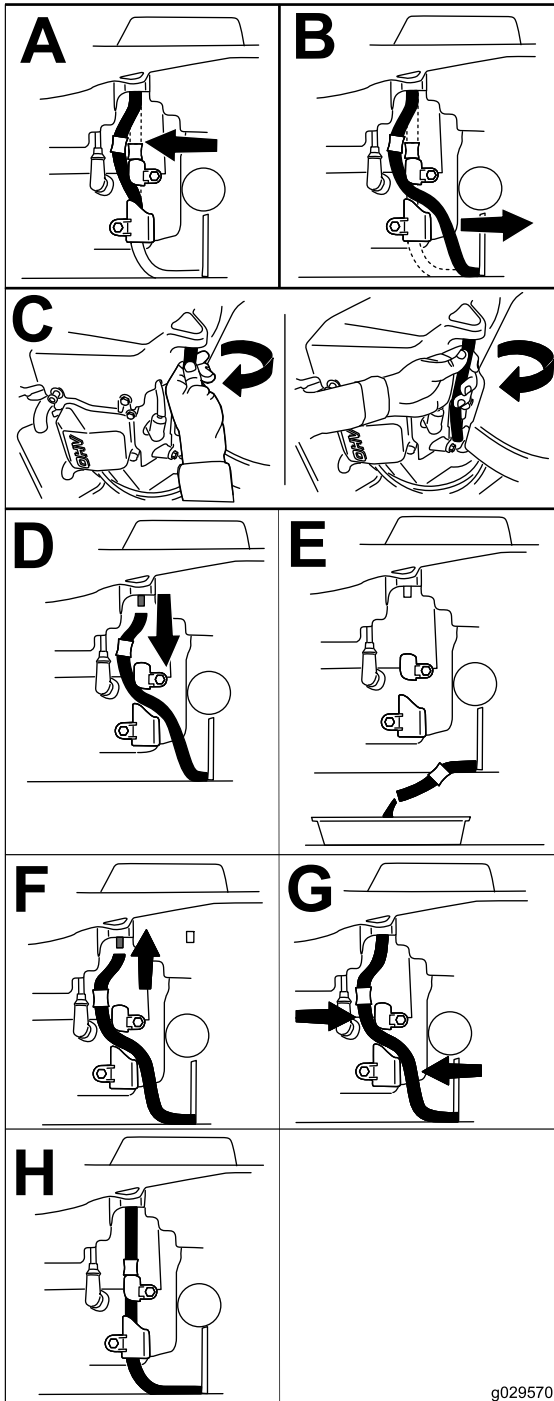

g029570

Figure 39

g029570

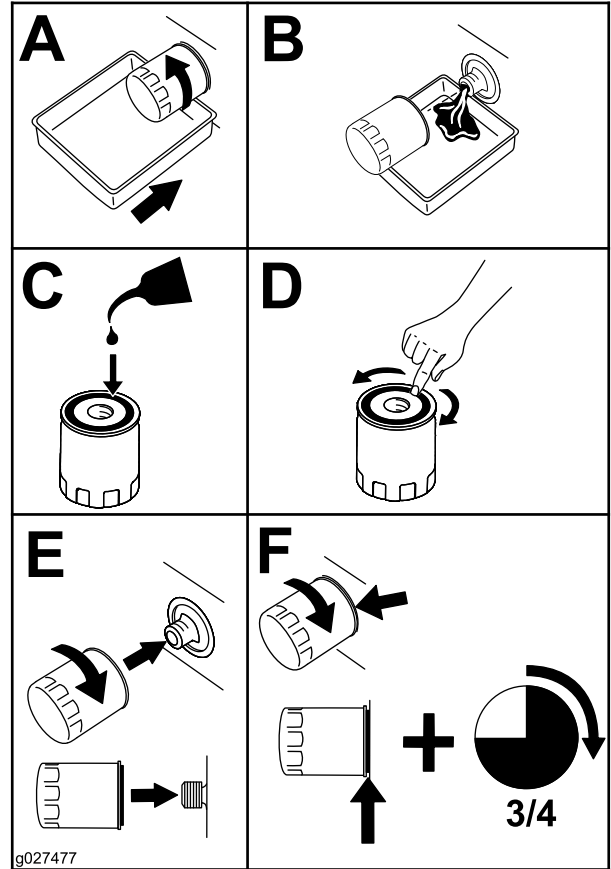

g027477

g027477

Figure 40

6. Slowly pour approximately 80% of the specified oil into the filler tube and slowly add the additional oil to bring it to the **Full** mark (Figure 41).

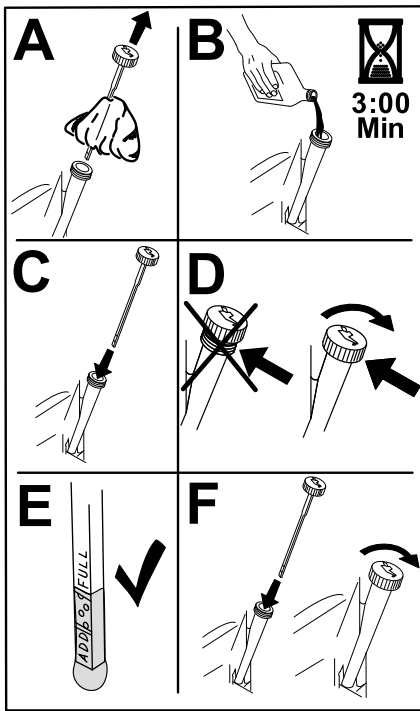

Figure 41

g193530

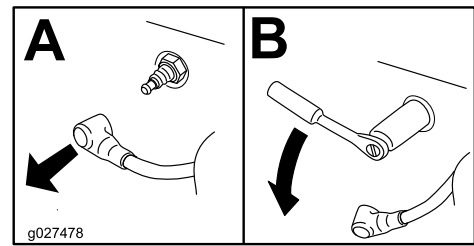

Figure 42

g027478

Note: Due to the deep recess around the spark plug, blowing out the cavity with compressed air is the most effective method for cleaning. The spark plug is most accessible when the blower housing is removed for cleaning.

Checking the Spark Plug

Important: Do not clean the spark plug(s). Always replace the spark plug(s) when it has: a black coating, worn electrodes, an oily film, or cracks.

If you see light brown or gray on the insulator, the engine is operating properly. A black coating on the insulator usually means the air cleaner is dirty.

Set the gap to 0.76 mm (0.03 inch).

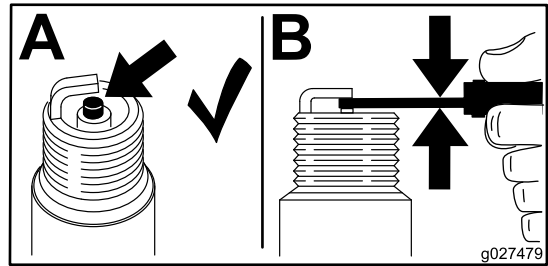

Figure 43

g027479

Servicing the Spark Plug

Service Interval: Every 100 hours/Yearly (whichever comes first)—Check the spark plug(s).

Every 200 hours/Every 2 years (whichever comes first)—Replace the spark plug(s).

Make sure that the air gap between the center and side electrodes is correct before installing the spark plug. Use a spark-plug wrench for removing and installing the spark plug(s) and a gapping tool/feeler gauge to check and adjust the air gap. Install a new spark plug(s) if necessary.

Type: Champion® RN9YC or NGK® BPR6ES

Air gap: 0.76 mm (0.03 inch)

Removing the Spark Plug

1. Disengage the PTO and ensure that the parking brake is engaged.
2. Shut off the engine, remove the key, and wait for all moving parts to stop before leaving the operating position.

Installing the Spark Plug

Tighten the spark plug(s) to 25 to 30 N·m (18.5 to 22.1 ft-lb).

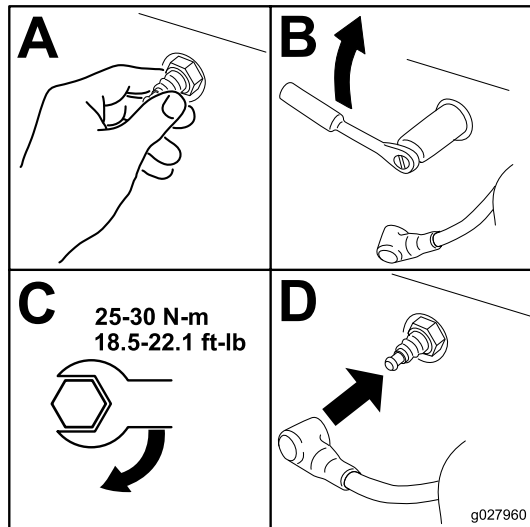

Figure 44

Cleaning the Cooling System

Clean the air intake screen from grass and debris before each use.

1. Disengage the blade-control switch and apply the parking brake.
2. Shut off the engine, remove the key, and wait for all moving parts to stop before leaving the operating position.
3. Remove the air filter from the engine.
4. Remove the engine shroud.
5. To prevent debris entering the air intake, install the air filter to the filter base.
6. Clean debris and grass from the parts.
7. Remove the air filter and install the engine shroud.
8. Install the air filter.

Fuel System Maintenance

⚠ DANGER

In certain conditions, fuel is extremely flammable and highly explosive. A fire or explosion from fuel can burn you, others, and can damage property.

- Perform any fuel-related maintenance when the engine is cold. Do this outdoors in an open area. Wipe up any fuel that spills.
- Never smoke when draining fuel, and stay away from an open flame or where a spark may ignite the fuel fumes.

Replacing the In-Line Fuel Filter

Service Interval: Every 100 hours/Yearly (whichever comes first)—Check the in-line fuel filter.

Every 200 hours/Every 2 years (whichever comes first)—Replace the in-line fuel filter.

Never install a dirty filter if it is removed from the fuel line.

1. Park the machine on a level surface and disengage the blade-control switch.
2. Ensure that the brake is engaged, shut off the engine, remove the key, and wait for all moving parts to stop before leaving the operating position.

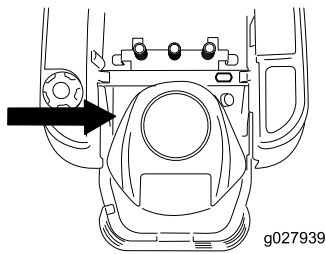

g027939

Electrical System Maintenance

Electrical System Safety

- Disconnect the battery before repairing the machine. Disconnect the negative terminal first and the positive last. Connect the positive terminal first and the negative last.
- Charge the battery in an open, well-ventilated area, away from sparks and flames. Unplug the charger before connecting or disconnecting the battery. Wear protective clothing and use insulated tools.

g027939

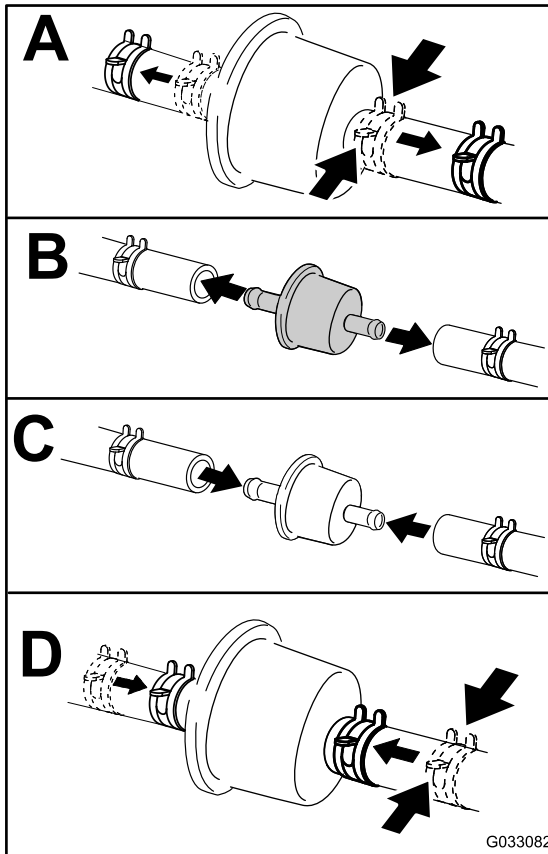

G033082

g033082

Figure 45

WARNING

CALIFORNIA Proposition 65 Warning

Battery posts, terminals, and related accessories contain lead and lead compounds, chemicals known to the State of California to cause cancer and reproductive harm. Wash hands after handling.

Servicing the Battery

Removing the Battery

⚠ WARNING

Battery terminals or metal tools could short against metal machine components causing sparks. Sparks can cause the battery gasses to explode, resulting in personal injury.

- When removing or installing the battery, do not allow the battery terminals to touch any metal parts of the machine.
 - Do not allow metal tools to short between the battery terminals and metal parts of the machine.
1. Park the machine on a level surface and disengage the blade-control switch.
 2. Ensure that the parking brake is engaged, shut off the engine, remove the key, and wait for all moving parts to stop before leaving the operating position.
 3. Loosen the 2 fasteners on the battery cover counterclockwise 1/4 turn, and remove the battery cover (Figure 46).

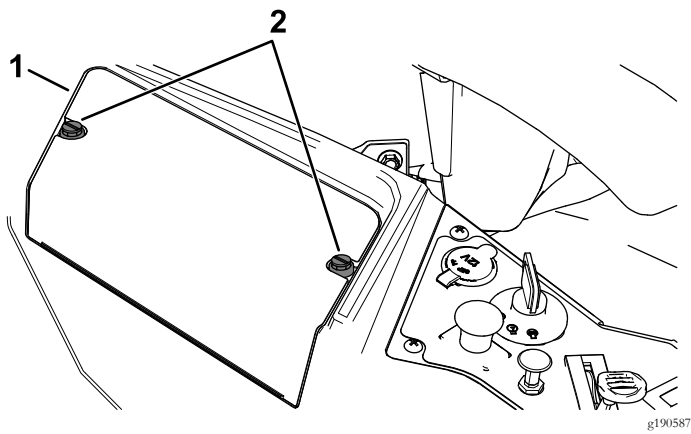

Figure 46

1. Battery cover
2. Fasteners

4. Disconnect the negative (black) ground cable from the battery post (Figure 47).

Note: Retain all fasteners.

⚠ WARNING

Incorrect battery-cable routing could damage the machine and cables causing sparks. Sparks can cause the battery gasses to explode, resulting in personal injury.

- Always disconnect the negative (black) battery cable before disconnecting the positive (red) cable.
- Always connect the positive (red) battery cable before connecting the negative (black) cable.

5. Slide the rubber cover up the positive (red) cable.
6. Disconnect the positive (red) cable from the battery post (Figure 47).

Note: Retain all fasteners.

7. Remove the battery hold-down (Figure 47), and lift the battery from the battery tray.

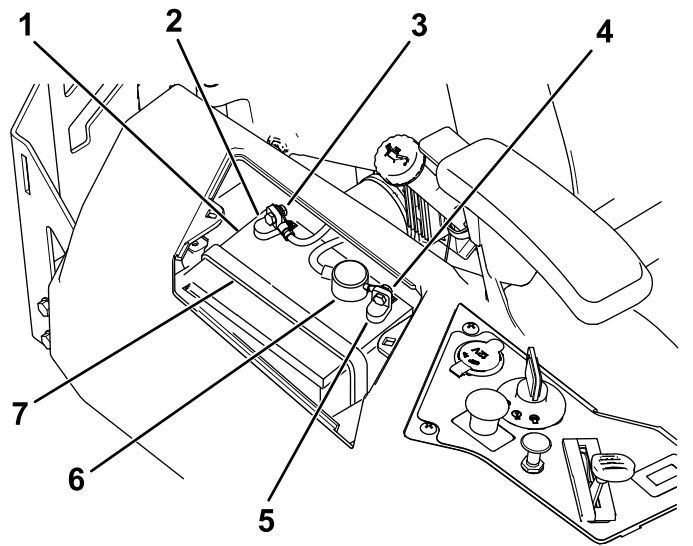

Figure 47

1. Battery
2. Negative (-) battery post
3. Bolt, washer, and nut for the negative (-) battery post
4. Bolt, washer, and nut for the positive (+) battery post
5. Positive (+) battery post
6. Terminal boot
7. Battery hold-down

Charging the Battery

Service Interval: Before storage—Charge the battery and disconnect the battery cables.

1. Remove the battery from the chassis; refer to [Removing the Battery](#) (page 36).
2. Charge the battery for a minimum of 1 hour at 6 to 10 A.

Note: Do not overcharge the battery.

3. When the battery is fully charged, unplug the charger from the electrical outlet, then disconnect the charger leads from the battery posts (Figure 48).

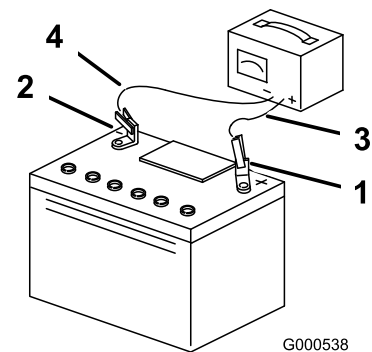

Figure 48

1. Positive (+) battery post
2. Negative (-) battery post
3. Red (+) charger lead
4. Black (-) charger lead

Installing the Battery

1. Position the battery in the tray (Figure 47).
2. Using the fasteners previously removed, install the positive (red) battery cable to the positive (+) battery terminal.
3. Using the fasteners previously removed, install the negative battery cable to the negative (-) battery terminal.
4. Slide the red terminal boot onto the positive (red) battery post.
5. Secure the battery with the hold-down (Figure 47).
6. Install the battery cover by pushing down and tightening the 2 fasteners clockwise (Figure 46).

Servicing the Fuses

The electrical system is protected by fuses. It requires no maintenance; however, if a fuse blows, check the component/circuit for a malfunction or short.

Fuse type:

- Main—F1 (15 A, blade-type)
- Charge Circuit—F2 (25 A, blade-type)

To replace the Main (15 A) fuse, reach into the opening in the side of the console, pull out the fuse, and installed a new 15 A fuse (Figure 49).

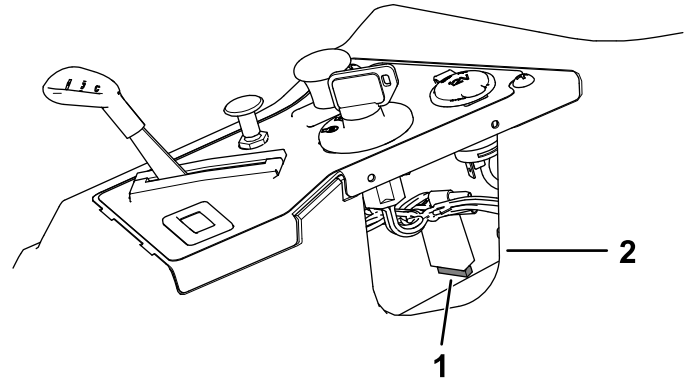

Figure 49

g190588

1. Main (15 A)
2. Console opening

To replace the Charge Circuit (25 A) fuse, locate the fuse to the left of battery, pull out the fuse, and installed a new 25 A fuse (Figure 50).

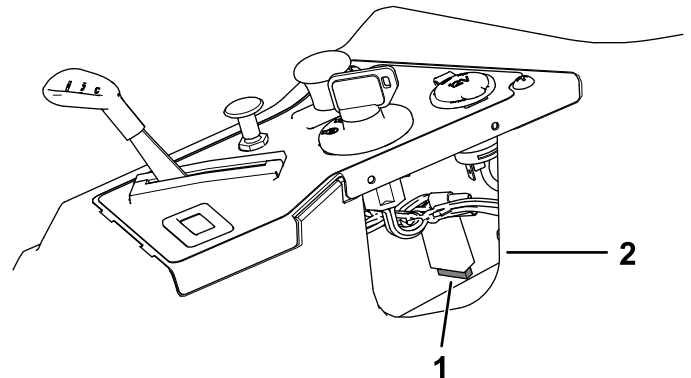

Figure 50

g190588

1. Charge circuit (25 A)

Drive System Maintenance

Checking the Tire Pressure

Service Interval: Every 25 hours—Check tire pressure.

Maintain the air pressure in the front and rear tires as specified. Uneven tire pressure can cause uneven cut. Check the pressure at the valve stem (Figure 51). Check the tires when they are cold to get the most accurate pressure reading.

Refer to the maximum pressure suggested by the tire manufacturer on the sidewall of the caster wheel tires.

Inflate the front caster wheel tires to 103 kPa (15 psi).

Inflate the rear drive wheel tires to 90 kPa (13 psi).

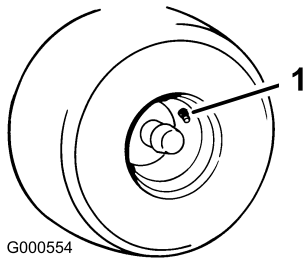

Figure 51

1. Valve stem

Mower Maintenance

Servicing the Cutting Blades

To ensure a superior quality of cut, keep the blades sharp. For convenient sharpening and replacement, keep extra blades on hand.

Blade Safety

A worn or damaged blade can break, and a piece of the blade could be thrown toward you or bystanders, resulting in serious personal injury or death. Trying to repair a damaged blade may result in discontinued safety certification of the product.

- Inspect the blades periodically for wear or damage.
- Use care when checking the blades. Wrap the blades or wear gloves, and use caution when servicing the blades. Only replace or sharpen the blades; never straighten or weld them.
- On multi-bladed machines, take care as rotating 1 blade can cause other blades to rotate.

Before Inspecting or Servicing the Blades

1. Park the machine on a level surface, disengage the blade-control switch (PTO), and engage the parking brake.
2. Shut off the engine, remove the key, and disconnect the spark-plug wires from the spark plugs.

Inspecting the Blades

Service Interval: Before each use or daily

1. Inspect the cutting edges (Figure 52).
2. If the edges are not sharp or have nicks, remove and sharpen the blade; refer to [Sharpening the Blades](#) (page 41).
3. Inspect the blades, especially in the curved area.
4. If you notice any cracks, wear, or a slot forming in this area, immediately install a new blade (Figure 52).

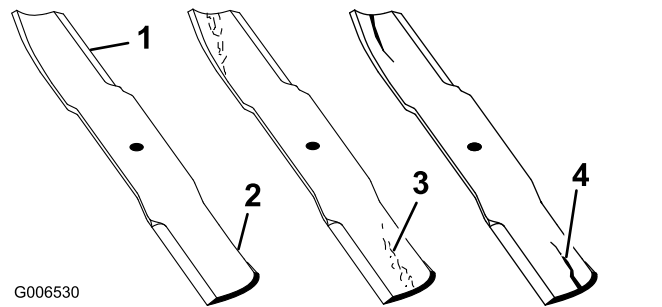

Figure 52

1. Cutting edge
2. Curved area
3. Wear/slot forming
4. Crack

Checking for Bent Blades

Note: The machine must be on a level surface for the following procedure.

1. Raise the mower deck to the highest height-of-cut position.
2. While wearing thickly padded gloves, or other adequate hand protection, slowly rotate the blade to be measure into a position that allows effective measurement of the distance between the cutting edge and the level surface the machine is on (Figure 53).

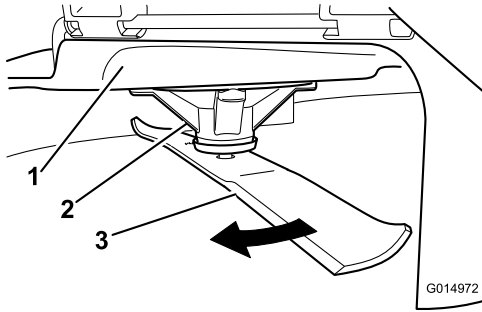

Figure 53

1. Deck
2. Spindle housing
3. Blade

3. Measure from the tip of the blade to the flat surface (Figure 54).

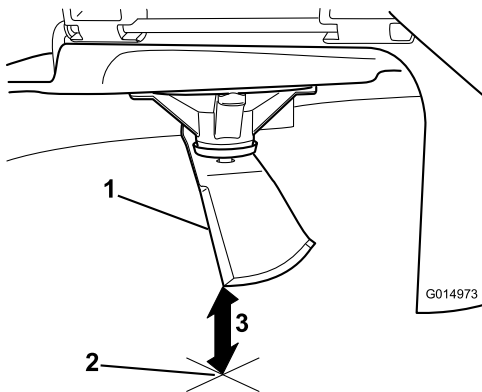

Figure 54

1. Blade (in position for measuring)
2. Level surface
3. Measured distance between blade and the surface (A)

4. Rotate the same blade 180 degrees so that the opposing cutting edge is now in the same position (Figure 55).

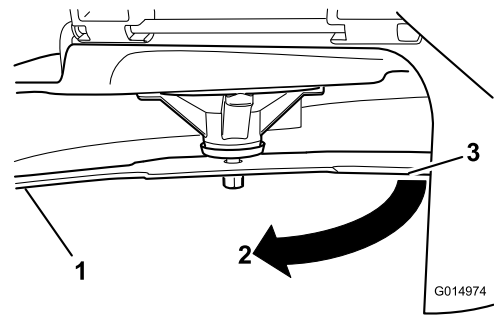

Figure 55

1. Blade (side previously measured)
2. Measurement (position used previously)
3. Opposing side of blade being moved into measurement position

5. Measure from the tip of the blade to the flat surface (Figure 56).

Note: The variance should be no more than 3 mm (1/8 inch).

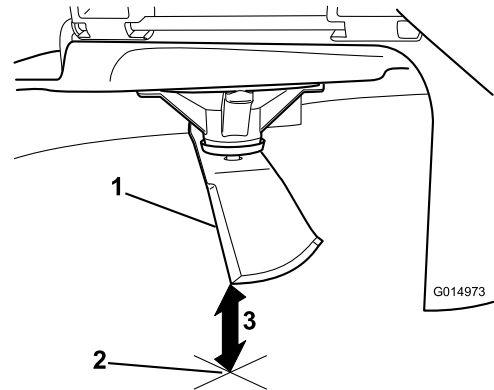

Figure 56

1. Opposite blade edge (in position for measuring)
2. Level surface
3. Second measured distance between blade and surface (B)

- A. If the difference between A and B is greater than 3 mm (1/8 inch), replace the blade with a new blade; refer to [Removing the Blades \(page 41\)](#) and [Installing the Blades \(page 41\)](#).

Note: If a bent blade is replaced with a new blade, and the dimension obtained continues to exceed 3 mm (1/8 inch), the blade spindle could be bent. Contact an Authorized Toro Dealer for service.

- B. If the variance is within constraints, move to the next blade.

6. Repeat this procedure on each blade.

Removing the Blades

The blades must be replaced if a solid object is hit, if the blade is out of balance, or if the blade is bent. For best performance and continued safety conformance of the machine, use genuine Toro replacement blades. Replacement blades made by other manufacturers may result in non-conformance with safety standards.

1. Hold the blade end using a rag or thickly padded glove.
2. Remove the blade bolt, curved washer, and blade from the spindle shaft (Figure 57).

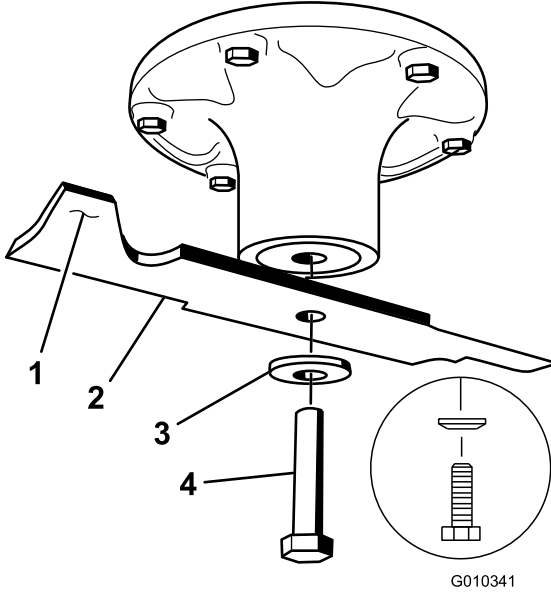

Figure 57

- | | |
|---------------------------|------------------|
| 1. Sail area of the blade | 3. Curved washer |
| 2. Blade | 4. Blade bolt |

Sharpening the Blades

1. Use a file to sharpen the cutting edge at both ends of the blade (Figure 58).

Note: Maintain the original angle.

Note: The blade retains its balance if the same amount of material is removed from both cutting edges.

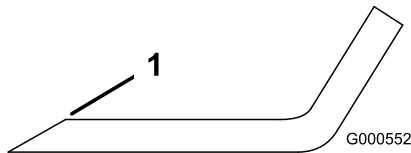

Figure 58

1. Sharpen at original angle.
2. Check the balance of the blade by putting it on a blade balancer (Figure 59).

Note: If the blade stays in a horizontal position, the blade is balanced and can be used.

Note: If the blade is not balanced, file some metal off the end of the sail area only (Figure 58).

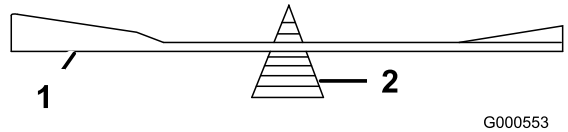

Figure 59

1. Blade
2. Balancer

3. Repeat this procedure until the blade is balanced.

Installing the Blades

1. Install the blade onto the spindle shaft (Figure 57).

Important: The curved part of the blade must be pointing upward toward the inside of the mower to ensure proper cutting.

2. Install the curved washer (cupped side toward the blade) and the blade bolt (Figure 57).
3. Torque the blade bolt to 135 to 150 N·m (100 to 110 ft-lb).

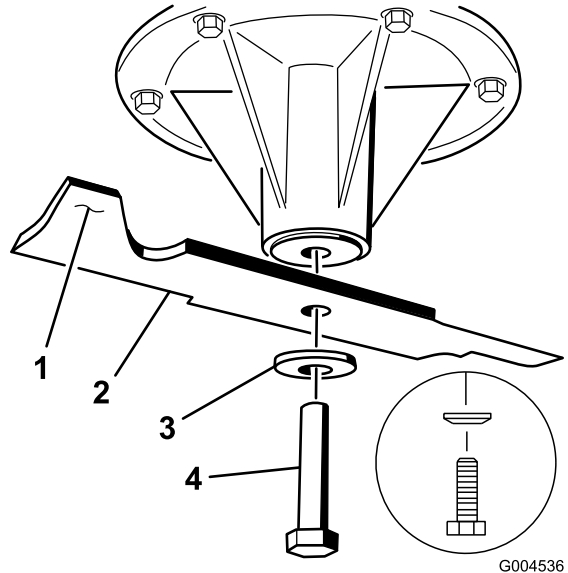

Figure 60

- | | |
|---------------------------|------------------|
| 1. Sail area of the blade | 3. Curved washer |
| 2. Blade | 4. Blade bolt |

Leveling the Mower Deck

Ensure that the mower deck is level any time you install the mower deck or when you see an uneven cut on your lawn.

Check the mower deck for bent blades prior to leveling; remove and replace any bent blades; refer to [Checking for Bent Blades \(page 40\)](#) before continuing.

Level the mower deck side-to-side before adjusting the front-to-rear slope.

Requirements:

- The machine must be on a level surface.
- All 4 tires must be properly inflated; refer to [Checking the Tire Pressure \(page 39\)](#).

Checking the Side-to-Side Level

The mower blades must be level from side to side. Check the side-to-side level any time you install the mower or when you see an uneven cut on your lawn.

1. Park the machine on a level surface and disengage the blade-control switch.
2. Move the motion-control levers outward to the NEUTRAL-LOCK position, shut off the engine, remove the key, engage the parking brake, and wait for all moving parts to stop before leaving the operating position.
3. Carefully rotate the blades side to side.
4. Measure between the outside cutting edges and the flat surface ([Figure 61](#)).

Note: If both measurements are not within 5 mm (3/16 inch), an adjustment is required; refer to [Leveling the Mower Deck \(page 43\)](#).

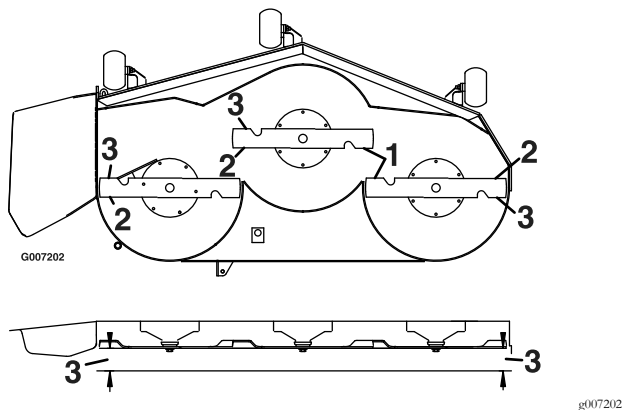

Figure 61

1. Blades side to side
2. Outside cutting edges
3. Measure from the tip of the blade to the flat surface here.

Checking the Front-to-Rear Blade Slope

Check the front-to-rear blade level any time you install the mower. If the front of the mower is more than 7.9 mm (5/16 inch) lower than the rear of the mower, adjust the blade level using the following instructions:

1. Park the machine on a level surface and disengage the blade-control switch.
2. Move the motion-control levers outward to the NEUTRAL-LOCK position, engage the parking brake, shut off the engine, remove the key, and wait for all moving parts to stop before leaving the operating position.
3. Carefully rotate the blades so they are facing front to rear ([Figure 62](#)).
4. Measure from the tip of the front blade to the flat surface and the tip of the rear blade to the flat surface ([Figure 62](#)).

Note: If the front blade tip is not 1.6 to 7.9 mm (1/16 to 5/16 inch) lower than the rear blade tip, continue to the [Leveling the Mower Deck \(page 43\)](#) procedure.

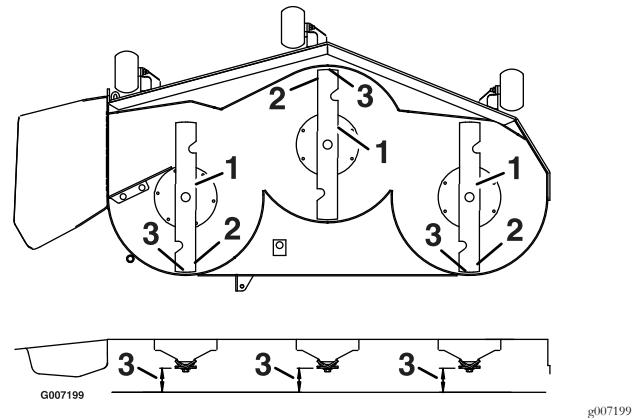

Figure 62

1. Blades front to rear
2. Outside cutting edges
3. Measure from the tip of the blade to the flat surface here.

Leveling the Mower Deck

1. Set the anti-scalp rollers to the top holes or remove them completely for this procedure; refer to [Adjusting the Anti-Scalp Rollers](#) (page 24).
2. Set the height-of-cut lever to the 76 mm (3 inch) position; refer to [Adjusting the Height of Cut](#) (page 23).
3. Place 2 blocks each having a thickness of 6.6 cm (2-5/8 inches) under each side of the front edge of the deck, but not under the anti-scalp roller brackets ([Figure 63](#)).
4. Place 2 blocks each having a thickness of 7.3 cm (2-7/8 inches) under the rear edge of the cutting deck skirt; 1 on each side of the cutting deck ([Figure 63](#)).

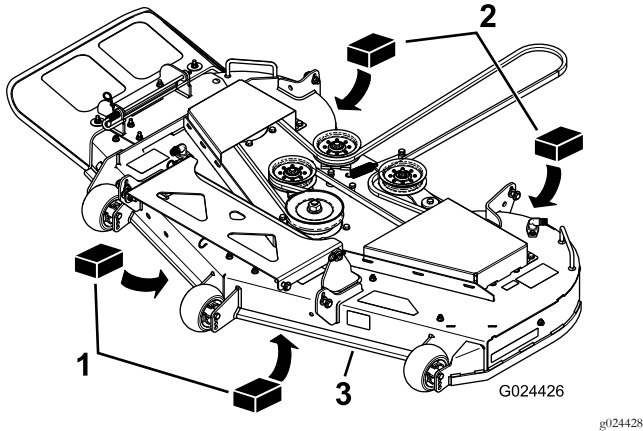

Figure 63

1. Wood block—6.6 cm (2-5/8 inches) thick
2. Wood block—7.3 cm (2-7/8 inches) thick
3. Front edge

5. Loosen the adjustment bolts on all 4 corners so that the deck is sitting securely on all 4 blocks ([Figure 64](#)).

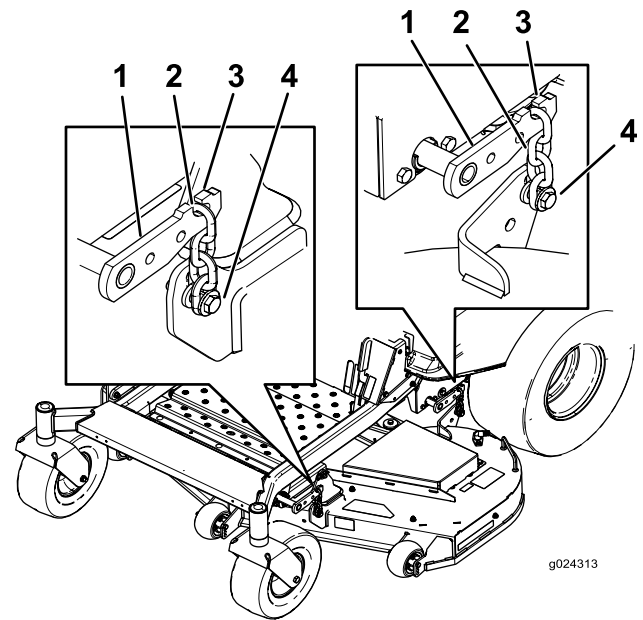

Figure 64

1. Deck-lift arm
2. Chain
3. Hook
4. Adjustment bolt

6. Ensure that there is tension on all 4 chains ([Figure 64](#)).
7. Tighten the 4 adjustment bolts ([Figure 64](#)).
8. Ensure that the blocks fit snugly under the deck skirt and that all bolts are tight.
9. Verify that the deck is level by checking the side-to-side level and front-to-rear blade slope; repeat the deck leveling procedure if necessary.

Removing the Mower Deck

Park the machine on a level surface, disengage the blade-control switch, move the motion-control levers outward to the NEUTRAL-LOCK position, engage the parking brake, shut off the engine, remove the key, and wait for all moving parts to stop before leaving the operating position.

Lower the mower to the lowest height of cut. Select 1 of the following procedures depending on the mower deck size installed to complete the removal.

Preparing to Remove the Mower Deck

1. Lower the mower to the 76 mm (3 inches) height-of-cut position.
2. Remove the mower belt from the engine pulley; refer to [Replacing the Mower Belt](#) (page 46).

Removing the Mower Deck

1. Remove the hairpin cotter and washer securing the link pin to the frame and deck, and remove the link bar (Figure 65).

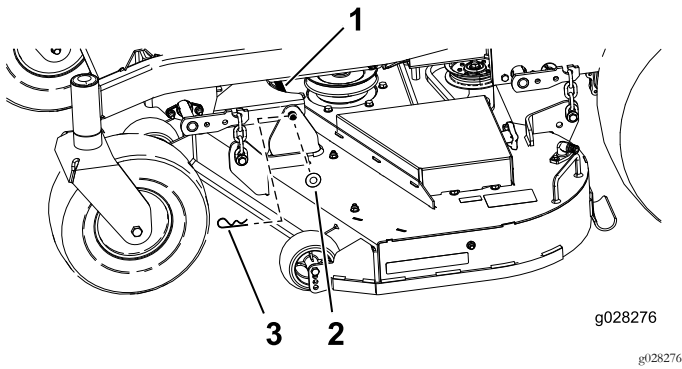

Figure 65

- | | |
|-------------|-------------------|
| 1. Link pin | 3. Hairpin cotter |
| 2. Washer | |

2. Lift up the mower deck to relieve tension from the mower deck.
3. Remove the chains from the hooks on the deck-lift arms (Figure 66).

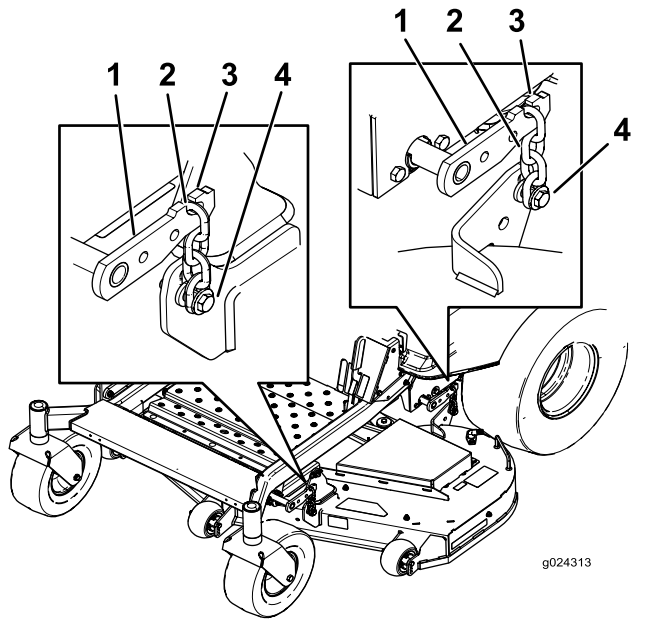

Figure 66

- | | |
|------------------|--------------------|
| 1. Deck-lift arm | 3. Hook |
| 2. Chain | 4. Adjustment bolt |

4. Raise the height of cut to the transport position.
5. Remove the belt from the clutch pulley on the engine.
6. Slide the mower out from underneath the machine.

Note: Retain all parts for future installation.

Installing the Mower Deck

1. Park the machine on a level surface and disengage the blade-control switch.
2. Move the motion-control levers outward to the NEUTRAL-LOCK position, shut off the engine, remove the key, engage the parking brake, and wait for all moving parts to stop before leaving the operating position.
3. Slide the mower under the machine.
4. Lower the height-of-cut lever to the lowest position.
5. Place the height-of-cut pin in the lock position for lowest height of cut.
6. Lift the rear of the mower deck and attach the chains to the rear lift arms (Figure 66).
7. Attach the front chains to the front lift arms (Figure 66).
8. Install the long link bar through the frame hanger and deck.
9. Secure the link pin with the hairpin cotters and washers removed previously (Figure 65).
10. Install the mower belt onto the engine pulley; refer to [Replacing the Mower Belt \(page 46\)](#).

Replacing the Grass Deflector

Service Interval: Before each use or daily—Inspect the grass deflector for damage.

⚠ WARNING

An uncovered discharge opening could allow the lawn mower to throw objects at you or bystanders and result in serious injury. Also, contact with the blade could occur.

Never operate the lawn mower unless you install a mulch plate, discharge deflector, or grass collection system.

Inspect the grass deflector for damage before each use. Replace any damaged parts before use.

1. Disengage the spring from the notch in the deflector bracket and slide the rod out of the welded deck brackets, spring, and discharge deflector (Figure 67).

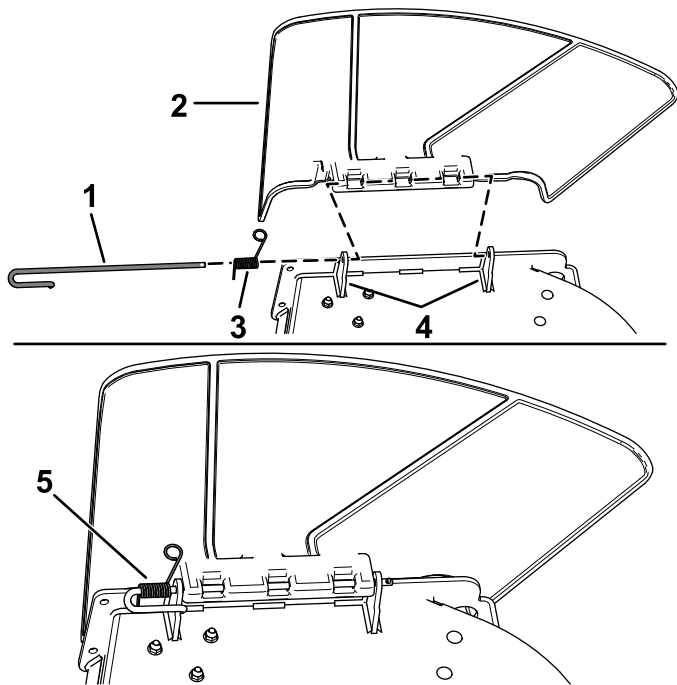

Figure 67

- | | |
|--------------|----------------------------------|
| 1. Rod | 4. Deck brackets |
| 2. Deflector | 5. Spring installed over the rod |
| 3. Spring | |

the bend and going over the rod as it returns from the bend.

6. Lift the loop end of the spring and place it into the notch on the deflector bracket (Figure 68).

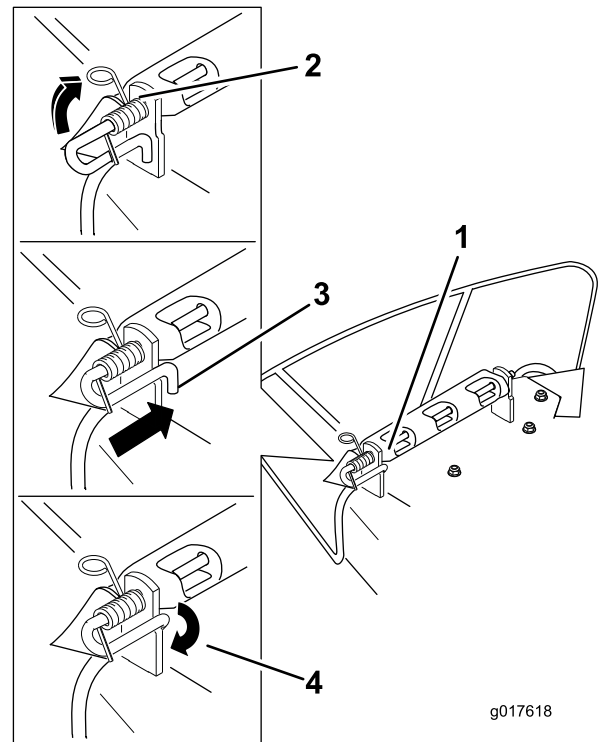

Figure 68

- | | |
|-----------------------------------------------------------------------------|-----------------------------------------------|
| 1. Rod and spring assembly installed | 3. Rod (short end) moved behind mower bracket |
| 2. Loop end of the spring installed into the notch in the deflector bracket | 4. Short end, retained by mower bracket. |

7. Secure the rod and spring assembly by twisting it so the short end of the rod is placed behind the front bracket welded to the deck (Figure 68).

Important: The grass deflector must be spring loaded in the down position. Lift the deflector up to test that it snaps to the full down position.

2. Remove the damaged or worn discharge deflector.
3. Position the new discharge deflector with the bracket ends between the welded brackets on the deck as shown in Figure 68.
4. Install the spring onto the straight end of the rod.
5. Position the spring on the rod as shown in so the shorter spring end is coming from under the rod before

Mower Belt Maintenance

Inspecting the Belts

Service Interval: Every 25 hours—Check the belts for wear or cracks.

Check the belts for cracks, frayed edges, burn marks, or any other damage. Replace damaged belts.

Replacing the Mower Belt

Squealing when the belt is rotating, blades slipping when cutting grass, frayed belt edges, burn marks, and cracks are signs of a worn mower belt. Replace the mower belt if any of these conditions are evident.

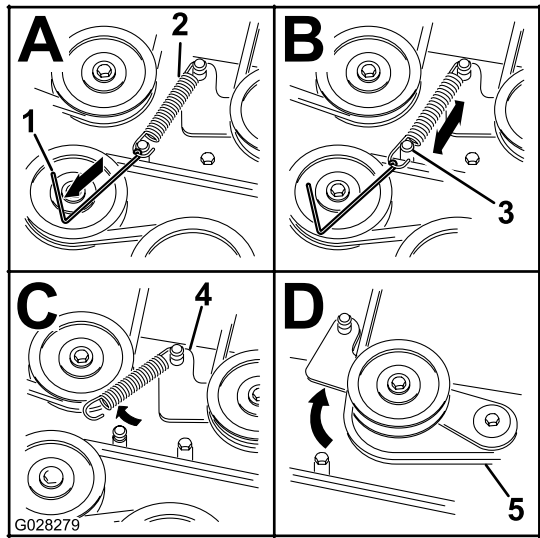

Figure 69

g028279

1. Disengage the blade-control switch (PTO), move the motion-control levers to the NEUTRAL-LOCK position, and engage the parking brake.
2. Shut off the engine, remove the key, and wait for all moving parts to stop before leaving the operating position.
3. Lower the mower to the 76 mm (3 inches) height-of-cut position.
4. For each of the belt covers, loosen the 2 bolts, **but do not remove them**.
5. Slide the cover until it is clear of the bolts and lift it up and out to remove it.
6. Remove the floor pan to access the idler pulley.
7. Using a spring removal tool, (Toro Part No. 92-5771), remove the idler spring from the deck post to remove tension on the idler pulley (Figure 69).

1. Spring-removal tool (Toro Part No. 92-5771)
2. Idler spring
3. Deck post
4. Idler arm
5. Mower belt

8. Lower the mower to the lowest height of cut and place the height-of-cut pin in the lock position for the lowest height-of-cut.
9. Remove the belt from the mower-deck pulleys and remove the existing belt.
10. Install the new belt around the mower pulleys and the clutch pulley under the engine (Figure 69).

▲ WARNING

The spring is under tension when installed and can cause personal injury.

Be careful when removing the belt.

11. Using a spring-removal tool, (Toro Part No. 92-5771), install the idler spring over the deck post and placing tension on the idler pulley and mower belt (Figure 69).
12. Ensure that the belt is properly seated in all pulleys.
13. To install the belt covers, insert the tabs on the each cover into the corresponding slots on the deck bracket, ensuring that they seat.
14. Rotate the cover to the deck and slide the notches under the loosened bolts until they are seated.
15. Tighten the bolts to secure the cover to the deck.

Cleaning

Washing the Underside of the Mower

Service Interval: After each use—Clean the mower-deck housing.

Important: You can wash the machine with a mild detergent and water. Do not pressure wash the machine. Avoid excessive use of water, especially near the control panel, under the seat, around the engine, hydraulic pumps, and motors.

Wash the underside of the mower after each use to prevent grass buildup for improved mulch action and clipping dispersal.

1. Park the machine on a level surface and disengage the blade-control switch.
2. Move the motion-control levers outward to the NEUTRAL-LOCK position, engage the parking brake, shut off the engine, remove the key, and wait for all moving parts to stop before leaving the operating position.
3. Attach the hose coupling to the end of the mower washout fitting, and turn the water on high (Figure 70).

Note: Spread petroleum jelly on the washout fitting O-ring to make the coupling slide on easier and protect the O-ring.

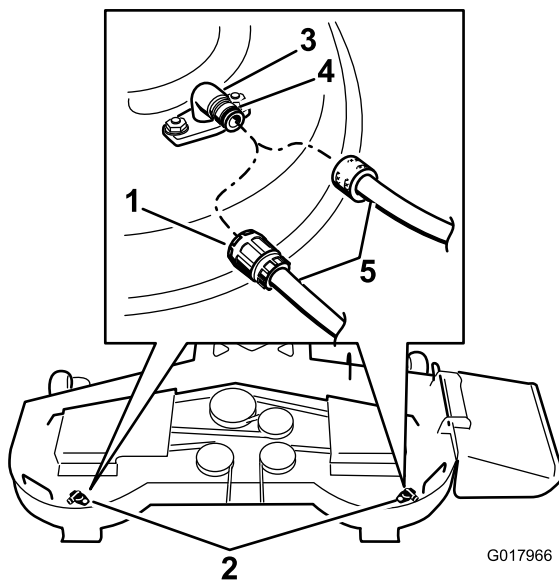

Figure 70

- | | |
|-----------------------------------------------|-----------|
| 1. Washout fitting locations on 54-inch decks | 4. O-ring |
| 2. Washout fitting locations on 48-inch decks | 5. Hose |
| 3. Washout fitting | |

4. Lower the mower to the lowest height of cut.
5. Sit on the seat and start the engine.
6. Engage the blade-control switch and let the mower run for 1 to 3 minutes.
7. Disengage the blade-control switch, shut off the engine, remove the ignition key, and wait for all moving parts to stop.
8. Turn the water off and remove the coupling from the washout fitting.

Note: If the mower is not clean after 1 washing, soak it and let it stand for 30 minutes. Then, repeat the process.

9. Run the mower again for 1 to 3 minutes to remove excess water.

▲ WARNING

A broken or missing washout fitting could expose you and others to thrown objects or blade contact. Contact with a blade or thrown debris can cause injury or death.

- Replace broken or missing washout fitting immediately, before using mower again.
- Never put your hands or feet under the mower or through openings in the mower.

Cleaning the Suspension System

Note: Do not clean the shock assemblies with pressurized water (Figure 71).

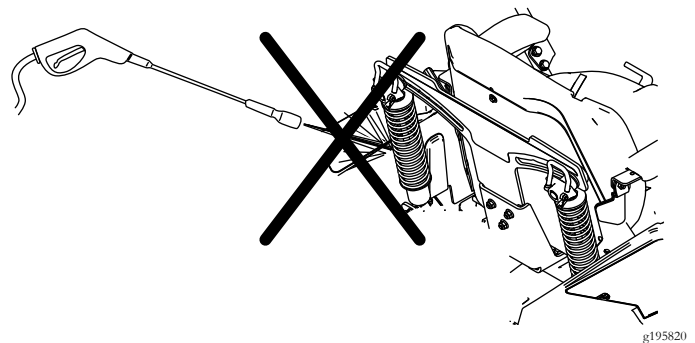

Figure 71

Disposing of Waste

Engine oil, batteries, hydraulic fluid, and engine coolant are pollutants to the environment. Dispose of these according to your state and local regulations.

Storage

Cleaning and Storage

1. Disengage the blade-control switch (PTO), engage the parking brake, turn the ignition key to the OFF position, and remove the key.
2. Remove grass clippings, dirt, and grime from the external parts of the entire machine, especially the engine and hydraulic system. Clean dirt and chaff from the outside of the engine cylinder head fins and blower housing.

Important: You can wash the machine with mild detergent and water. Do not pressure wash the machine. Avoid excessive use of water, especially near the control panel, engine, hydraulic pumps, and motors.

3. Check the parking brake operation; refer to [Operating the Parking Brake \(page 18\)](#).
4. Service the air cleaner; refer to [Servicing the Air Cleaner \(page 30\)](#).
5. Change the crankcase oil; refer to [Changing the Engine Oil and Oil Filter \(page 32\)](#).
6. Check the tire pressure; refer to [Checking the Tire Pressure \(page 39\)](#).
7. Charge the battery; refer to [Charging the Battery \(page 37\)](#).
8. Scrape any heavy buildup of grass and dirt from the underside of the mower, then wash the mower with a garden hose.

Note: Run the machine with the blade-control switch (PTO) engaged and the engine at high idle for 2 to 5 minutes after washing.

9. Check the condition of the blades; refer to [Servicing the Cutting Blades \(page 39\)](#).
10. Prepare the machine for storage when non-use occurs over 30 days. Prepare the machine for storage as follows:
 - A. Add a petroleum based stabilizer/conditioner to fuel in the tank. Follow mixing instructions from the stabilizer manufacturer. Do not use an alcohol based stabilizer (ethanol or methanol).

Note: A fuel stabilizer/conditioner is most effective when mixed with fresh fuel and used at all times.

 - B. Run the engine to distribute conditioned fuel through the fuel system (5 minutes).
 - C. Shut off the engine, allow it to cool, and drain the fuel tank.
 - D. Start the engine and run it until it shuts off.

- E. Dispose of fuel properly. Recycle the fuel according to local codes.

Important: Do not store stabilizer/conditioned fuel over 90 days.

11. Check and tighten all bolts, nuts, and screws. Repair or replace any part that is damaged.
12. Paint all scratched or bare metal surfaces. Paint is available from your Authorized Service Dealer.
13. Store the machine in a clean, dry garage or storage area. Remove the key from the ignition switch and keep it out of reach of children or other unauthorized users. Cover the machine to protect it and keep it clean.

Troubleshooting

Problem	Possible Cause	Corrective Action
The fuel tank is showing signs of collapsing or the machine is showing signs of frequently running out of fuel.	1. The air-cleaner paper element clogged.	1. Clean the paper element.
The engine overheats.	<ol style="list-style-type: none"> 1. The engine load is excessive. 2. The oil level in the crankcase is low. 3. The cooling fins and air passages under the engine blower housing are plugged. 4. The air cleaner is dirty. 5. Dirt, water, or stale fuel is in fuel system. 	<ol style="list-style-type: none"> 1. Reduce ground speed. 2. Add oil to the crankcase. 3. Remove the obstruction from the cooling fins and air passages. 4. Clean or replace the air-cleaner element. 5. Contact an Authorized Service Dealer
The starter does not crank.	<ol style="list-style-type: none"> 1. The motion-control levers are not in the NEUTRAL-LOCK position. 2. The parking brake is disengaged. 3. The battery is dead. 4. The electrical connections are corroded or loose. 5. A fuse is blown. 6. A relay or switch is damaged. 	<ol style="list-style-type: none"> 1. Move the motion-control levers to the NEUTRAL-LOCK position. 2. Engage the parking brake. 3. Charge the battery. 4. Check the electrical connections for good contact. 5. Replace the fuse. 6. Contact an Authorized Service Dealer.
The engine does not start, starts hard, or fails to keep running.	<ol style="list-style-type: none"> 1. The fuel tank is empty. 2. The choke is not on. 3. The air cleaner is dirty. 4. The spark-plug wire(s) is loose or disconnected. 5. The spark plug(s) is pitted, fouled, or the gap is incorrect. 6. There is dirt in fuel filter. 7. Dirt, water, or stale fuel is in fuel system. 8. There is incorrect fuel in the fuel tank. 9. The oil level in the crankcase is low. 	<ol style="list-style-type: none"> 1. Fill the fuel tank. 2. Move the choke lever to On. 3. Clean or replace the air-cleaner element. 4. Install the wire(s) on the spark plug. 5. Install a new, correctly gapped spark plug(s). 6. Replace the fuel filter. 7. Contact an Authorized Service Dealer. 8. Drain the tank and replace the fuel with the proper type. 9. Add oil to the crankcase.
The engine loses power.	<ol style="list-style-type: none"> 1. The engine load is excessive. 2. The air cleaner is dirty. 3. The oil level in the crankcase is low. 4. The cooling fins and air passages under the engine blower housing are plugged. 5. The spark plug(s) is pitted, fouled, or the gap is incorrect. 6. The fuel tank vent is blocked. 7. There is dirt in the fuel filter. 8. Dirt, water, or stale fuel is in the fuel system. 9. There is incorrect fuel in the fuel tank. 	<ol style="list-style-type: none"> 1. Reduce ground speed. 2. Clean the air-cleaner element. 3. Add oil to the crankcase. 4. Remove the obstruction from the cooling fins and air passages. 5. Install a new, correctly gapped spark plug(s). 6. Contact an Authorized Service Dealer. 7. Replace the fuel filter. 8. Contact an Authorized Service Dealer. 9. Drain the tank and replace the fuel with the proper type.

Problem	Possible Cause	Corrective Action
The machine does not drive.	<ol style="list-style-type: none"> 1. The bypass valves are open. 2. The traction belts are worn, loose, or broken. 3. The traction belts are off of the pulleys. 4. The transmission has failed. 	<ol style="list-style-type: none"> 1. Close the tow valves. 2. Contact an Authorized Service Dealer. 3. Contact an Authorized Service Dealer. 4. Contact an Authorized Service Dealer.
There is an abnormal vibration.	<ol style="list-style-type: none"> 1. The engine-mounting bolts are loose. 2. The engine pulley, idler pulley, or blade pulley is loose. 3. The engine pulley is damaged. 4. The cutting blade(s) is/are bent or unbalanced. 5. A blade-mounting bolt is loose. 6. A blade spindle is bent. 	<ol style="list-style-type: none"> 1. Tighten the engine-mounting bolts. 2. Tighten the appropriate pulley. 3. Contact an Authorized Service Dealer. 4. Install a new cutting blade(s). 5. Tighten the blade-mounting bolt. 6. Contact an Authorized Service Dealer.
The cutting height is uneven.	<ol style="list-style-type: none"> 1. The blade(s) is not sharp. 2. A cutting blade(s) is/are bent. 3. The mower is not level. 4. An anti-scalp wheel is not set correctly. 5. The underside of the mower is dirty. 6. The tire pressure is incorrect. 7. A blade spindle is bent. 	<ol style="list-style-type: none"> 1. Sharpen the blade(s). 2. Install a new cutting blade(s). 3. Level the mower from side-to-side and front-to-rear. 4. Adjust the anti-scalp wheel height. 5. Clean the underside of the mower. 6. Adjust the tire pressure. 7. Contact an Authorized Service Dealer.
The blades do not rotate.	<ol style="list-style-type: none"> 1. The drive belt is worn, loose or broken. 2. The drive belt is off of the pulley. 3. The power-takeoff (PTO) switch or PTO clutch is faulty. 4. The mower belt is worn, loose, or broken. 	<ol style="list-style-type: none"> 1. Install a new drive belt. 2. Install the drive belt and check the adjusting shafts and belt guides for the correct position. 3. Contact an Authorized Service Dealer. 4. Install a new mower belt.



The Toro Warranty

Limited Warranty (see warranty periods below)

Conditions and Products Covered

The Toro Company and its affiliate, Toro Warranty Company, pursuant to an agreement between them, jointly promise to repair the Toro Products listed below if defective in materials or workmanship.

The following time periods apply from the original date of purchase:

Products	Warranty Period
TimeCutter Mowers • Engines ¹ — Residential use	Residential Use ² – 3 years Kawasaki – 3 years Kohler – 3 years Toro – 3 years
TimeCutter Mowers • Engines ¹ — Commercial use	Commercial use 30 days Kawasaki – 3 years Kohler – 90 days Toro Single Cylinder – 90 days Toro Twin Cylinder – 3 years / 300 Hours ³
TimeCutter HD Mowers • Engines ¹ — Residential and Commercial Use	3 years or 300 Hours ³ 3 years or 300 Hours ³
All Mowers • Attachments	1 year
• Battery	90 days Parts and Labor 1 year Parts only
• Belts and Tires	90 days

¹Some engines used on Toro Products are warranted by the engine manufacturer.

²Residential use means use of the product on the same lot as your home. Use at more than one location is considered commercial use and the commercial use warranty would apply.

³Whichever occurs first.

Warranty may be denied if the hour meter is disconnected, altered, or shows signs of being tampered with.

Owner Responsibilities

You must maintain your Toro Product by following the maintenance procedures described in the *Operator's Manual*. Such routine maintenance, whether performed by a dealer or by you, is at your expense.

Instructions for Obtaining Warranty Service

If you think that your Toro Product contains a defect in materials or workmanship, follow this procedure:

- Contact any Authorized Toro Service Dealer to arrange service at their dealership. To locate a dealer convenient to you, access our web site at www.Toro.com. You may also call the numbers listed in item #3 to use the 24-hour Toro Dealer locator system.
- Bring the product and your proof of purchase (sales receipt) to the Service Dealer. The dealer will diagnose the problem and determine if it is covered under warranty.

Countries Other than the United States or Canada

This warranty is not valid in Mexico. Customers who have purchased Toro products outside the United States or Canada should contact their Toro Distributor (Dealer) to obtain guarantee policies for your country, province, or state. If for any reason you are dissatisfied with your Distributor's service or have difficulty obtaining guarantee information, contact the Toro importer. If all other remedies fail, you may contact us at Toro Warranty Company.

Australian Consumer Law: Australian customers will find details relating to the Australian Consumer Law either inside the box or at your local Toro Dealer.

- If for any reason you are dissatisfied with the Service Dealer's analysis or with the assistance provided, contact us at:

Toro Warranty Company
 Customer Care Department, RLC Division
 8111 Lyndale Avenue South
 Bloomington, MN 55420-1196
 Toll free at 866-216-6029 (U.S. customers)
 Toll free at 866-216-6030 (Canadian customers)

Items and Conditions Not Covered

There is no other express warranty except for special emission system coverage and engine warranty coverage on some products. This express warranty does not cover the following:

- Cost of regular maintenance service or parts, such as filters, fuel, lubricants, oil changes, spark plugs, air filters, blade sharpening or worn blades, cable/linkage adjustments, or brake and clutch adjustments
- Components failing due to normal wear
- Any product or part which has been altered, misused, neglected, requires replacement or repair due to accidents or lack of proper maintenance
- Pickup and delivery charges
- Repairs or attempted repairs by anyone other than an Authorized Toro Service Dealer
- Repairs necessary due to failure to follow recommended fuel procedure (consult *Operator's Manual* for more details)
 - Removing contaminants from the fuel system is not covered
 - Use of old fuel (more than one month old) or fuel which contains more than 10% ethanol or more than 15% MTBE
 - Failure to drain the fuel system prior to any period of non-use over one month

General Conditions

All repairs covered by these warranties must be performed by an Authorized Toro Service Dealer using Toro approved replacement parts.

Neither The Toro Company nor Toro Warranty Company is liable for indirect, incidental or consequential damages in connection with the use of the Toro Products covered by this warranty, including any cost or expense of providing substitute equipment or service during reasonable periods of malfunction or non-use pending completion of repairs under this warranty.

All implied warranties of merchantability (that the product is fit for ordinary use) and fitness for use (that the product is fit for a particular purpose) are limited to the duration of the express warranty.

Some states do not allow exclusions of incidental or consequential damages, or limitations on how long an implied warranty lasts, so the above exclusions and limitations may not apply to you.

This warranty gives you specific legal rights, and you may also have other rights which vary from state to state.