

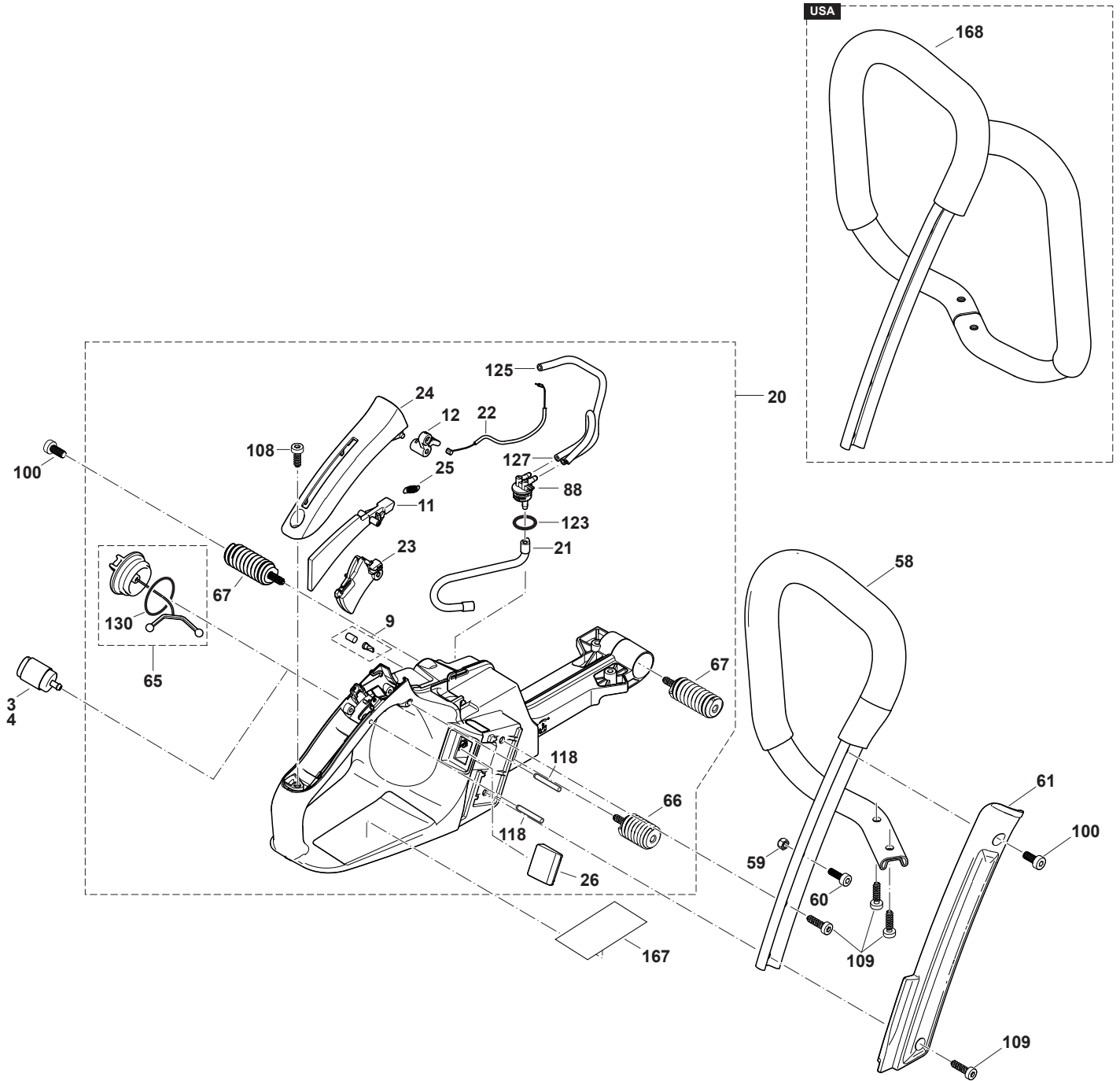

EA6100P53G



Products with multiple versions are listed in subsiding order with the newest version on top not indented.

Section	Fig. No.	Part No.	Description	EA6100P53G	Tech Bulletin	Notes
1 4		010-114-020	REP. KIT, FILTER (5 OF EACH)	1		FOR 010114010
1 4		010-114-010	SUCTION HEAD	1		
1 9		195762-4	AIR VALVE CPL.	1		
1 11		038-117-020	CATCH LEVER	1		
1 12		038-117-030	ROCKER	1		
1 20		130-114-600	TANK CPL. BLUE	1		
1 21		130-114-050	FUEL LINE	1		
1 22		130-117-040	CONTROL CABLE	1		
1 23		130-117-010	THROTTLE LEVER	1		
1 24		130-117-050	GRIP OUTER SHELL	1		
1 25		130-117-060	TENSION SPRING	1		
1 26		130-148-650	COVER HANDLE HEATING	1		
1 58		130-310-100	TUBULAR HANDLE ASSY.	1		INC. 59, 60
1 59		920-405-000	HEXAGONAL NUT	1		M5
1 60		908-005-165	H.L. SOCKET HEAD BOLT	1		M5X16
1 61		130-310-650	COVER TUBULAR HANDLE	1		
1 65		181-114-202	TANK CAP CPL.	2		
1 66		130-114-400	DAMPING SPRING CPL.	1		
1 67		181-114-301	DAMPING SPRING, CPL.	2		
1 88		195-114-060	FUEL NIPPLE	1		
1 100		908-006-145	SCREW	4		M6X14
1 108		913-455-164	SCREW	1		5,5X16
1 109		913-455-204	SCREW	4		5,5X20
1 118		935-930-280	CYLINDRICAL PIN	2		Ø3X28
1 125		965-452-660	TUBE	1		5,6/3MMX1M EPA CODE, RED L=160MM
1 127		965-452-090	TUBE	1		2,5/5,5MM X1M L=148MM
1 130		963-229-036	PACKING RING	2		29,3X3,6
1 168		130-310-350	WRAP AROUND HANDLE ASSY.	1		USA (INC. 59, 60)

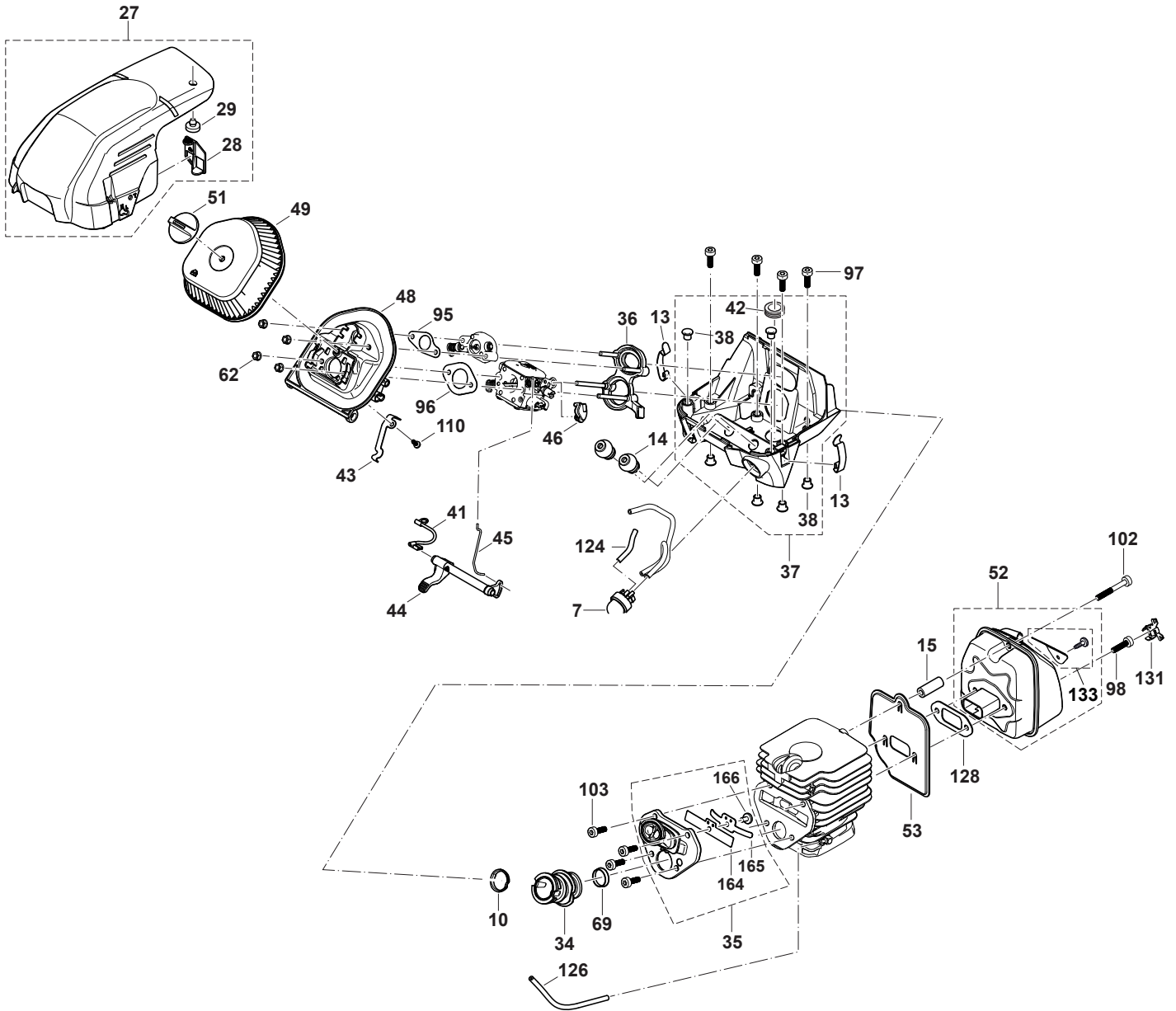

Products with multiple versions are listed in subsiding order with the newest version on top not indented.

Section	Fig. No.	Part No.	Description	EA6100P53G	Tech Bulletin	Notes
2	7	130-153-500	PRIMER	1		PRIMER
2	10	130-131-020	INSERT FOR SUCTION HOSE	1		
2	13	130-118-070	STEELCLIP	3		
2	14	038-171-030	HOLDER	2		
2	15	038-174-030	CONNECTING LINK	1		L=26,8MM
2	27	130-118-600	HOOD CPL.	1		
2	28	130-118-140	INSERT SUMMER / WINTER	1		
2	29	965-402-360	RUBBER BUFFER	1		
2	34	130-131-031	SUCTION HOSE	1		
2	35	130-131-160	AIR HOSE CPL.	1		
2	36	130-131-070	FLANGE RING	1		
2	37	130-131-600	CARBURETOR HOUSING BLUE ASSY.	1		
2	38	001-118-100	BUSHING	6		
2	41	130-147-020	EARTH CABLE	1		
2	43	130-155-010	CONTACT SPRING	1		
2	44	130-155-020	CHOKE LEVER	1		
2	45	130-155-040	CHOKE SHAFT	1		
2	46	175-155-082	BOWDEN CABLE FIXTURE	1		
2	48	130-171-010	INTAKE MANIFOLD	1		
2	49	130-173-010	AIR FILTER	1		POLYESTER
2	51	130-173-060	CLAMPING BOLT	1		
2	52	130-174-100	MUFFLER CPL.	1		
2	53	130-174-090	COOLING PLATE	1		
2	62	175-131-300	HEXAGONAL NUT WITH COLLAR	4		
2	69	130-131-050	INSERT	1		
2	95	315-155-010	GASKET AIR VALVE	1		
2	96	315-155-020	GASKET INTAKE MANIFOLD	1		
2	97	908-005-165	H.L. SOCKET HEAD BOLT	7		M5X16
2	98	908-005-205	SCREW	2		M5X20
2	102	908-305-405	H.L. SOCKET HEAD BOLT	1		M5X40
2	103	908-405-145	SCREW	4		M5X14
2	110	915-735-100	SCREW	1		3,5X10
2	124	965-452-090	TUBE	1		2,5/5,5MM X1M L=60MM
2	126	965-452-090	TUBE	1		2,5/5,5MM X1M L=148MM

Products with multiple versions are listed in subsiding order with the newest version on top not indented.

Section	Fig. No.	Part No.	Description	EA6100P53G	Tech Bulletin	Notes
2	128	395-174-120	GASKET	1		
2	131	038-174-451	PLUG FOR MUFFLER TUBE	2		
2	133	130-174-150	SPARK ARRESTER SCREEN CPL.	1		
2	164	315-179-010	VALVE STOPPER	1		
2	165	315-179-021	LEAD VALVE	1		
2	166	908-004-085	SCREW	1		M4X8 INNEN6RD S LK

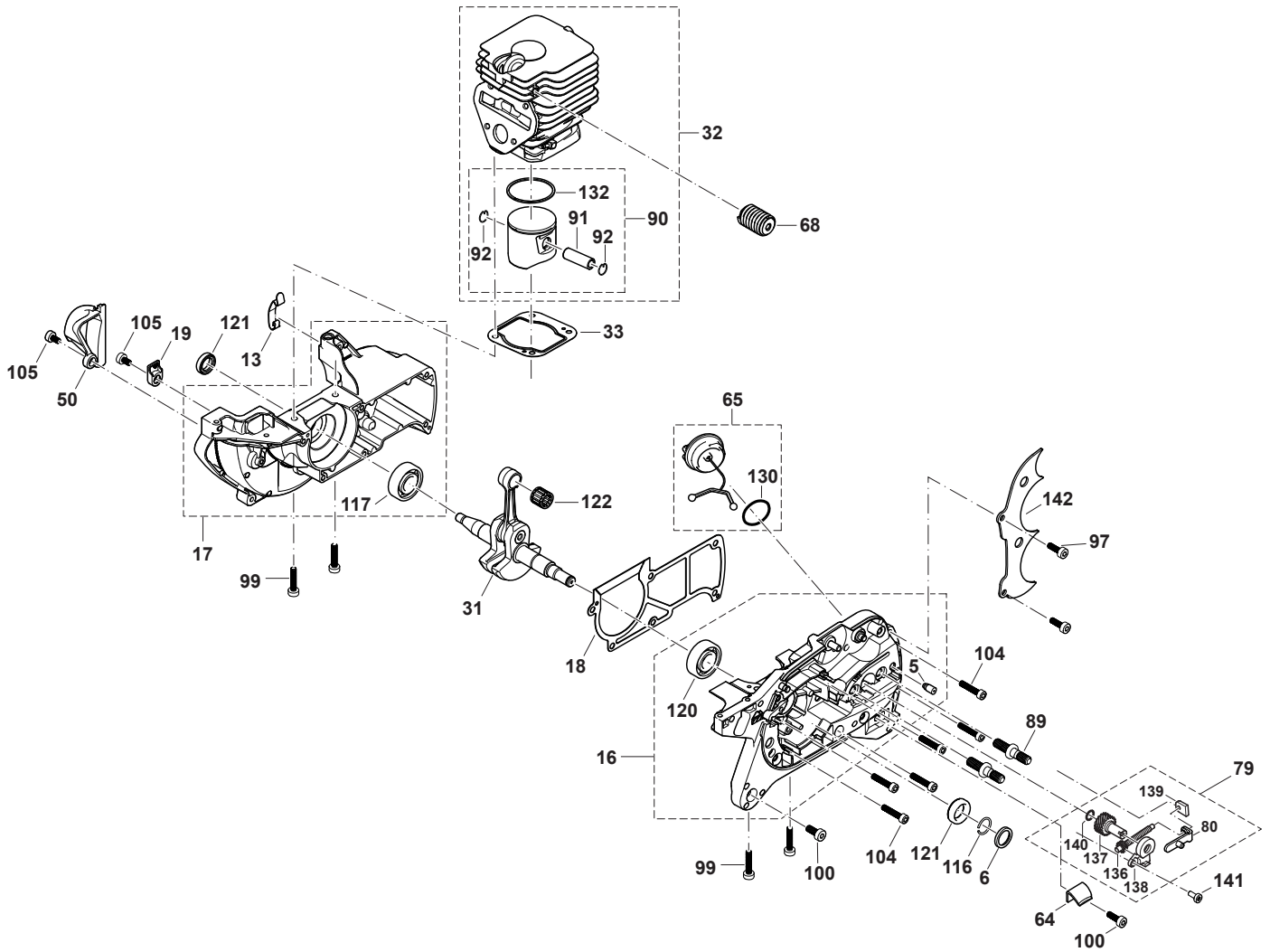

Products with multiple versions are listed in subsiding order with the newest version on top not indented.

Section	Fig. No.	Part No.	Description	EA6100P53G	Tech Bulletin	Notes
3	5	010-245-030	VENT VALVE	1		
3	6	394-245-010	STOP RING	1		
3	13	130-118-070	STEELCLIP	3		
3	16	130-111-610	CRANKCASE CL. SIDE ASSY.	1		
3	17	130-111-620	CRANKCASE MAGNETO-SIDE ASSY.	1		
3	18	130-111-070	CRANK CASE GASKET	1		
3	19	130-111-090	CLAMP	1		
3	31	130-120-102	CRANKSHAFT COMPLETE	1		
3	32	130-131-150	CYLINDER / PISTON CPL.	1		Ø 47MM
3	33	315-131-020	GASKET	1		
3	50	130-173-080	SUCTION PIPE	1		
3	64	181-111-050	CHAIN CATCH	1		
3	65	181-114-202	TANK CAP CPL.	2		
3	68	181-114-401	DAMPING SPRING, CPL.	1		
3	79	130-213-150	CHAIN TENSIONER CPL.	1		PROFI
3	80	130-213-240	TENSION SLIDE	1		PROFI
3	89	195-232-010	BOLT	2		M8
3	90	315-132-101	PISTON CPL.	1		D47
3	91	315-132-050	PISTON PIN	1		
3	92	315-132-040	CIRCLIP	2		11
3	97	908-005-165	H.L. SOCKET HEAD BOLT	7		M5X16
3	99	908-005-255	PAN HEAD ALLEN SCREW	4		M5X25
3	100	908-006-145	SCREW	4		M6X14
3	104	908-405-255	SCREW	6		M5X25
3	105	908-005-095	SCREW	2		M5X9
3	116	930-916-160	SPRING RING	1		
3	120	960-102-152	BALL BEARING (USE GLUE)	1		6202
3	120	960-102-152	BALL BEARING (USE GLUE)	1		6202
3	121	962-900-052	RADIAL RING	2		Ø15/24X7
3	122	962-210-111	NEEDLE CAGE	1		
3	130	963-229-036	PACKING RING	2		29,3X3,6
3	132	315-132-020	PISTON RING	1		D47
3	136	181-213-230	TENSIONING SCREW	1		PROFI
3	137	181-213-250	ADJUSTING SCREW	1		PROFI

Products with multiple versions are listed in subsiding order with the newest version on top not indented.

Section	Fig. No.	Part No.	Description	EA6100P53G	Tech Bulletin	Notes
3	138	181-213-270	TRANSMISSION COVER	1		PROFI
3	139	181-213-260	TENSIONING SCREW BEARING	1		
3	140	963-207-020	PACKING RING	1		7X2
3	141	908-705-125	SCREW	1		M5X12
3	142	130-250-020	SPIKE BAR	1		USA
4	30	130-118-040	AIR GUIDE PLATE	1		

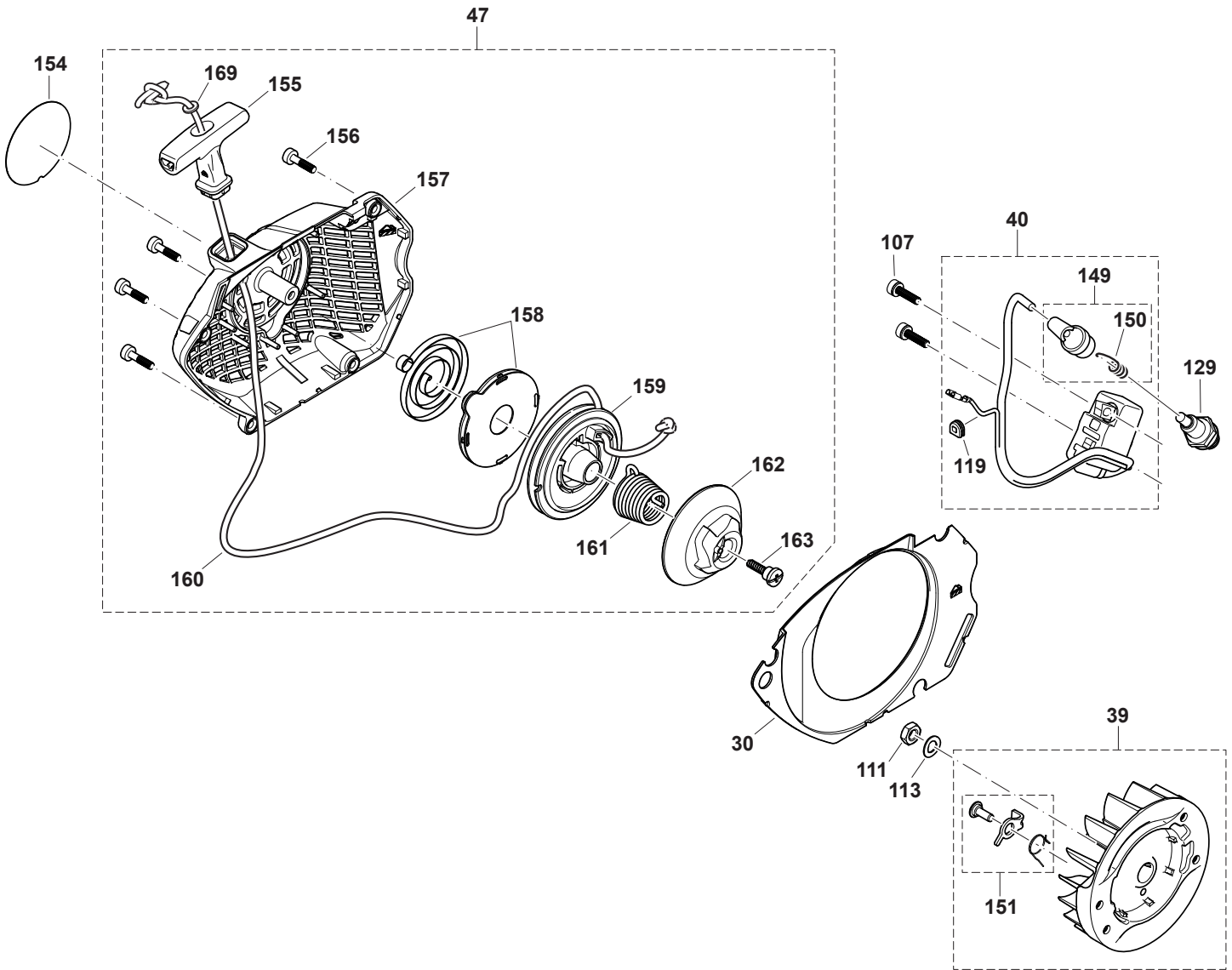

Products with multiple versions are listed in subsiding order with the newest version on top not indented.

Section	Fig. No.	Part No.	Description	EA6100P53G	Tech Bulletin	Notes
4	39	130-141-100	FLYWHEEL CPL.	1		
4	40	130-143-100	IGNITION COIL COMPLETE	1		
4	47	130-160-600	STARTER ASSY., BLUE	1		
4	107	908-805-205	SCREW	2		M5X20
4	111	920-308-024	HEXAGONAL NUT	1		M8X1
4	113	267822-3	SPRING WASHER	1		
4	119	965-401-016	RUBBER BUSH	1		
4	129	965-603-021	SPARK PLUG	1		
4	149	957-604-260	SPARK PLUG CAP CPL.	1		
4	150	965-604-180	SPRING	1		
4	151	130-141-150	STARTER RATCHET CPL.	2		
4	154	980-115-856	LABEL	1		EA6100P
4	155	181-164-010	STARTER KNOB	1		
4	156	908-005-205	SCREW	4		M5X20
4	157	130-160-630	STARTER ASSY. BLUE	1		
4	158	181-163-050	REWIND SPRING IN HOUSING	1		
4	159	315-162-020	CABLE DRUM	1		
4	160	181-164-020	STARTER ROPE	1		Ø 3,5 X 1000 MM
4	161	181-163-080	SPRING EASY-START	1		
4	162	315-163-090	STARTER WHEEL	1		
4	163	181-163-095	SCREW	1		
5	2	001-182-042	DISC	1		44,5X1X12

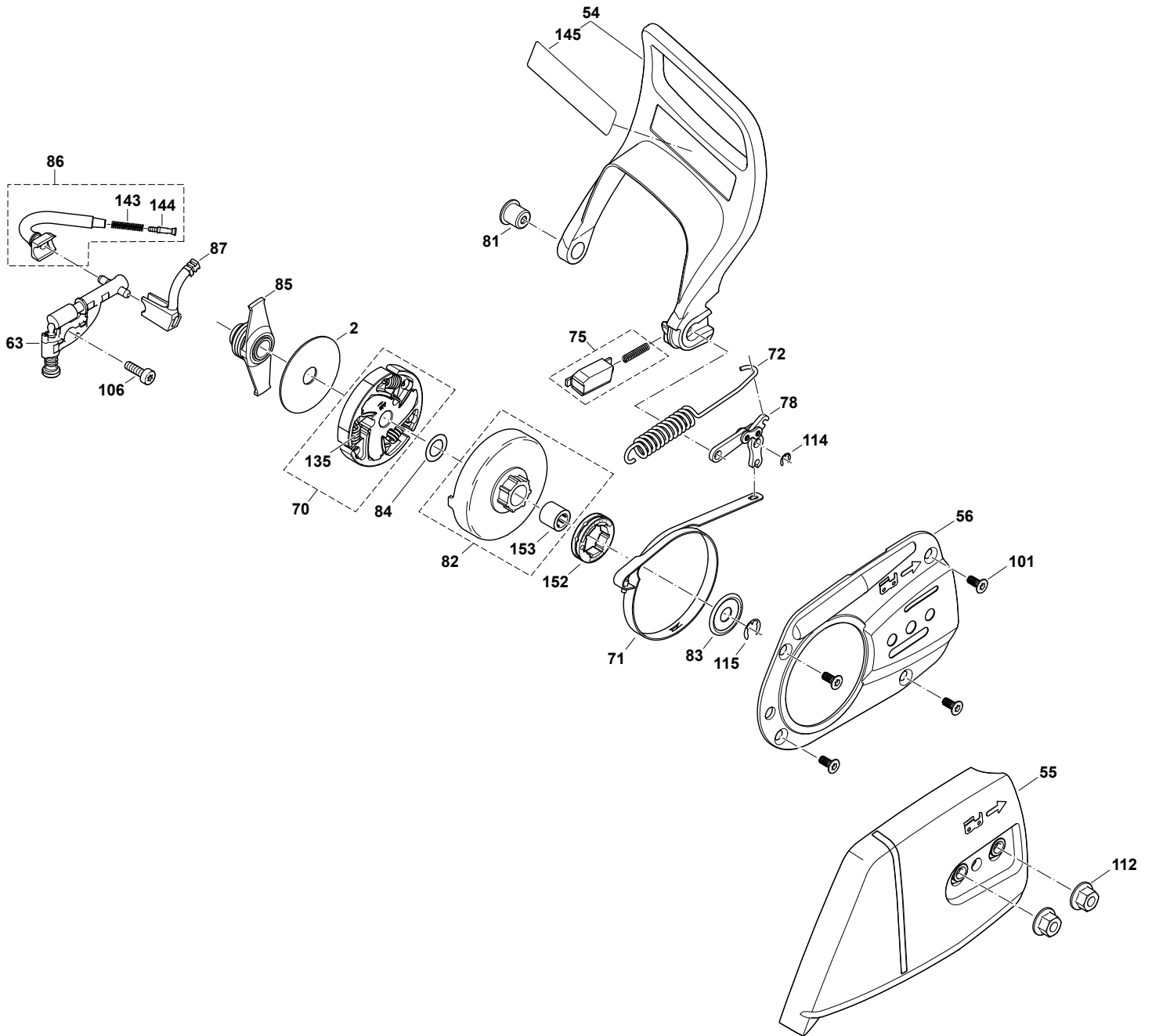

Products with multiple versions are listed in subsiding order with the newest version on top not indented.

Section	Fig. No.	Part No.	Description	EA6100P53G	Tech Bulletin	Notes
5	54	130-213-200	HAND GUARD CPL.	1		EU
5	54	130-213-220	HAND GUARD CPL.	1		USA
5	55	130-213-600	SPROCKET GUARD CPL.	1		
5	56	130-213-190	CHAIN BRAKE COVER	1		
5	70	175-180-101	CLUTCH ASSY.	1		
5	71	181-213-011	BRAKE SPRING	1		
5	72	181-213-023	TENSION SPRING	1		
5	75	181-213-170	HANDGUARD GUIDE, CPL.	1		
5	78	163500-2	BRAKING MECHANISM	1		
5	81	181-213-320	BUSHING	1		
5	82	181-223-062	CLUTCH DRUM CPL.	1		SMALL
5	83	181-224-081	DISC	1		
5	84	181-224-090	SHIM	1		10X18X0,5
5	85	181-245-090	PUMP DRIVE	1		
5	86	181-245-100	SUCTION LINE	1		
5	87	181-245-120	PRESSURE LINE	1		
5	101	908-105-124	SCREW	4		M5X12
5	106	908-705-125	SCREW	1		M5X12
5	112	923-208-004	HAXAGONAL NUT	2		M8
5	114	927-304-000	SAFETY WASHER	1		
5	115	927-408-000	WASHER	1		D=8X1,3
5	135	024-184-021	SPRING	3		
5	143	231975-4	SPRING	1		
5	144	001-245-020	HOSE STEM	1		
5	145	185-114-237	LABEL	1		
5	145	980-115-808	CAUTION LABEL	1		US WARNING SPARKS
5	152	181-224-040	RIM SPROCKET	1		325", Z=7, SM
5	152	026-224-010	RIM SPROCKET	1		3/8", Z=7, SM
5	153	962-300-009	NEEDLE SLEEVE	1		10/14X12
6	400	130-153-100	CARBURETOR	1		DM27, DD - EU, USA (REGULATED MARKET)

450

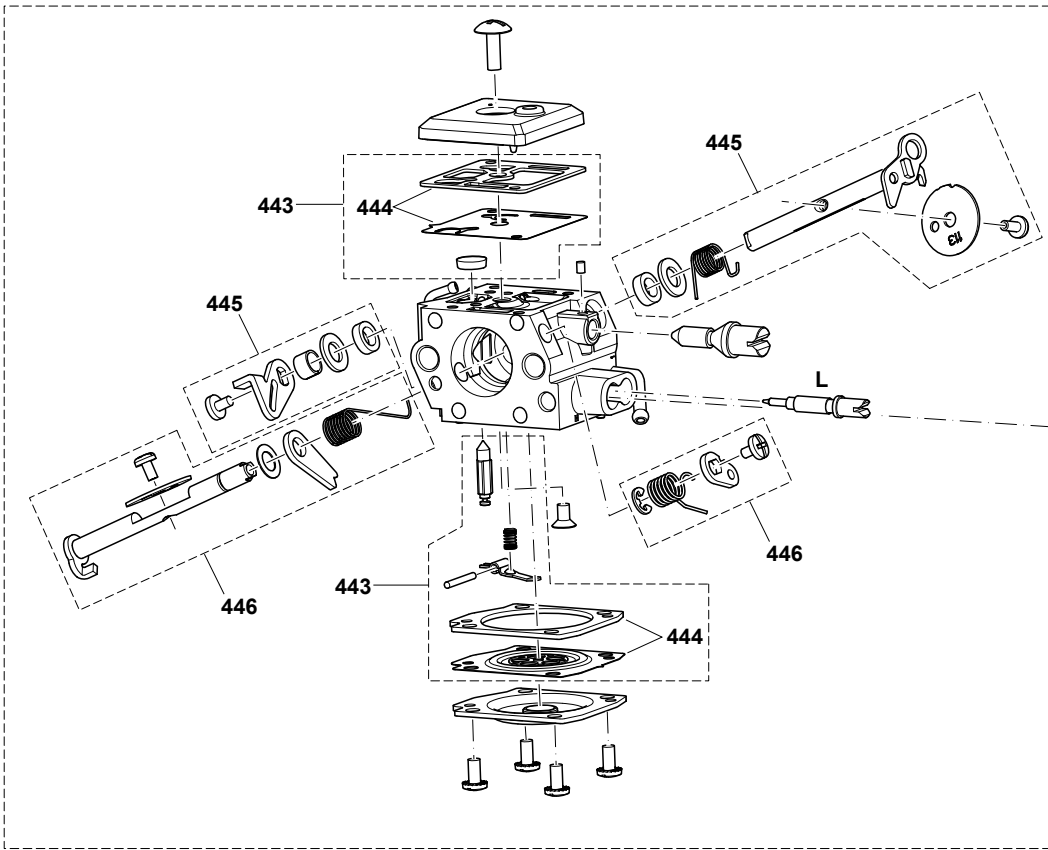
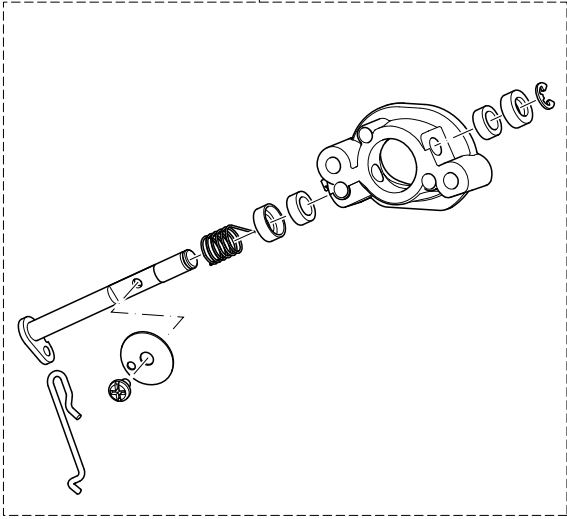

Products with multiple versions are listed in subsiding order with the newest version on top not indented.

Section	Fig. No.	Part No.	Description	EA6100P53G	Tech Bulletin	Notes
6	443	130-153-130	REPAIR KIT	1		
6	444	315-153-690	GASKET & DIAPHRAGM KIT	1		
6	445	130-153-150	THROTTLE KIT	1		
6	446	130-153-160	CHOKE KIT	1		
6	450	130-153-700	AIR FLAP CPL.	1		
7	518	952-020-650	CHAIN PROTECTION	1		50 CM
7	520	957-004-002	TOOL CPL.	1		

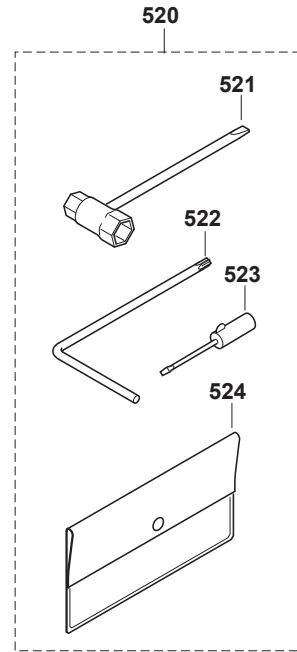
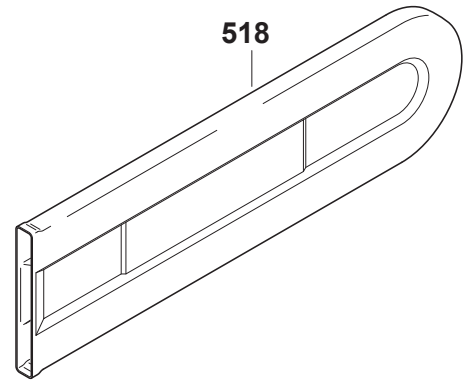
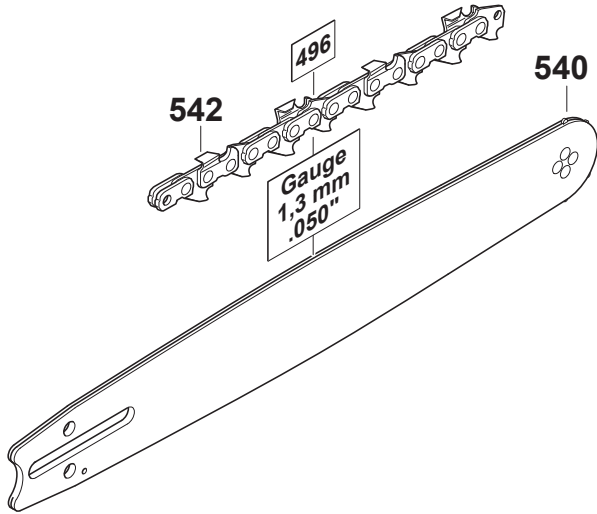

Products with multiple versions are listed in subsiding order with the newest version on top not indented.

Section	Fig. No.	Part No.	Description	EA6100P53G	Tech Bulletin	Notes
7	521	941-719-131	UNIVERSAL WRENCH	1		SW 13/19 MM
7	522	940-827-000	ANGLED SCREW DRIVER	1		T27
7	523	944-340-001	SCREWDRIVER	1		
7	524	950-004-002	PLASTIK BAG	1		
7	540	443-053-661	SPROCKET NOSE BAR	1		3/8" .050" 53CM-21"
7	542	523-102-072A	SAW CHAIN U.S.A.	1		3/8" .050" 50CM-20"