

H O M E

DECORATORS

C O L L E C T I O N

PROVENCE SINGLE BOOKCASE

INV#9939000510



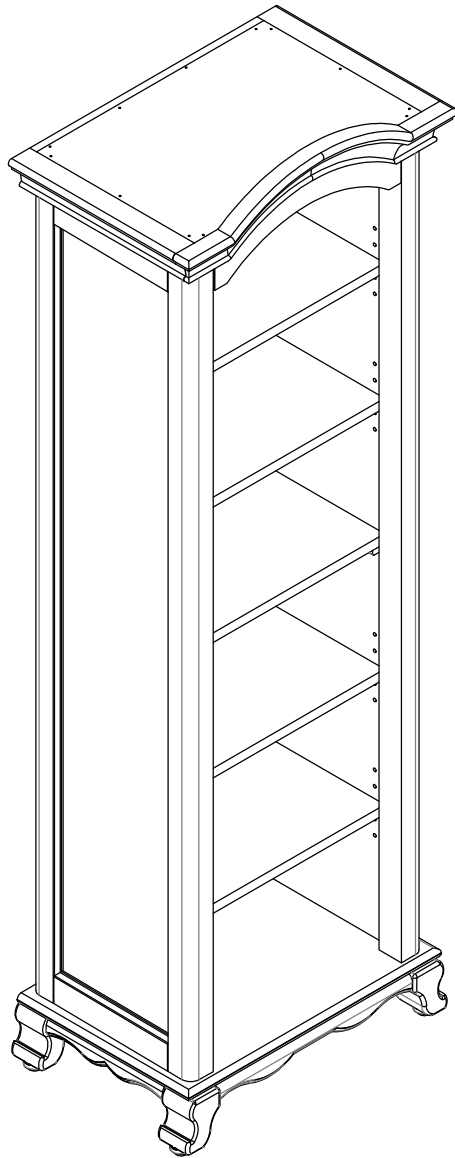

ASSEMBLY INSTRUCTIONS

MADE IN CHINA

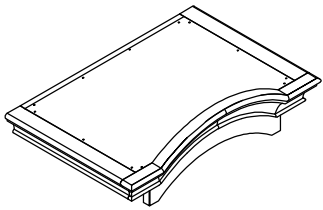
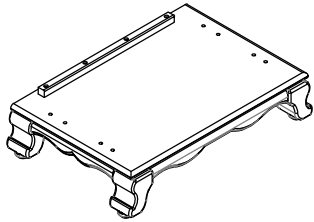
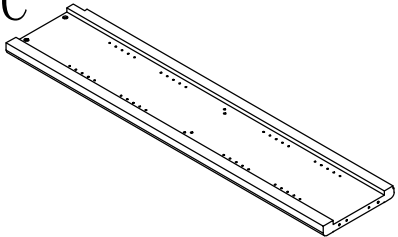
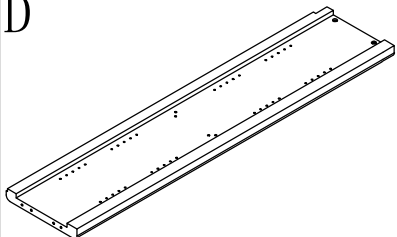
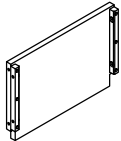
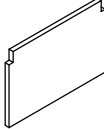
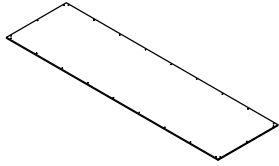

Thank you for purchasing this quality product. Be sure to check all packing material carefully for small parts, which may have come loose inside the carton during shipment. Count all parts and material hardware, then compare with parts list to be sure all parts are present. If any parts are missing or damaged, phone, fax, or mail to our Customer Service Department for efficient and speedy service. Please indicate the model number and code letter of part(s) needed.

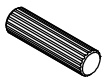
IMPORTANT NOTE: Follow instructions listed below in proper sequence as numbered to assure fast, easy and correct assembly.

PARTS LIST		
<p>A</p>  <p>TOP PANEL-1PC</p>	<p>B</p>  <p>BOTTOM PANEL-1PC</p>	<p>C</p>  <p>LEFT SIDE PANEL-1PC</p>
<p>D</p>  <p>RIGHT SIDE PANEL-1PC</p>	<p>E</p>  <p>FIXED PANEL-1PC</p>	<p>F</p>  <p>ADJUSTABLE SHELF-4PCS</p>
<p>G</p>  <p>REAR PANEL-1PC</p>	<p>H</p> <p>$\phi 1/4 \times 1-1/4$"</p>  <p>BOLT-4PCS</p>	<p>I</p> <p>$\phi 1/4 \times 1$"</p>  <p>BOLT-8PCS</p>
<p>J</p> <p>$\phi 8 \times 30$</p>  <p>WOOD DOWEL-8PCS</p>	<p>K</p> <p>$\phi 3.5 \times 15$</p>  <p>SCREW-23PCS</p>	<p>L</p>  <p>FLAT WASHER-12PCS</p>

M



SPRING WASHER-12PCS

N



SHELF HOLDER-16PCS

O



ALLEN KEY-1PC

--

--

--

--

--

--

--

--

--

--

--

--

--

--

--

--

--

--

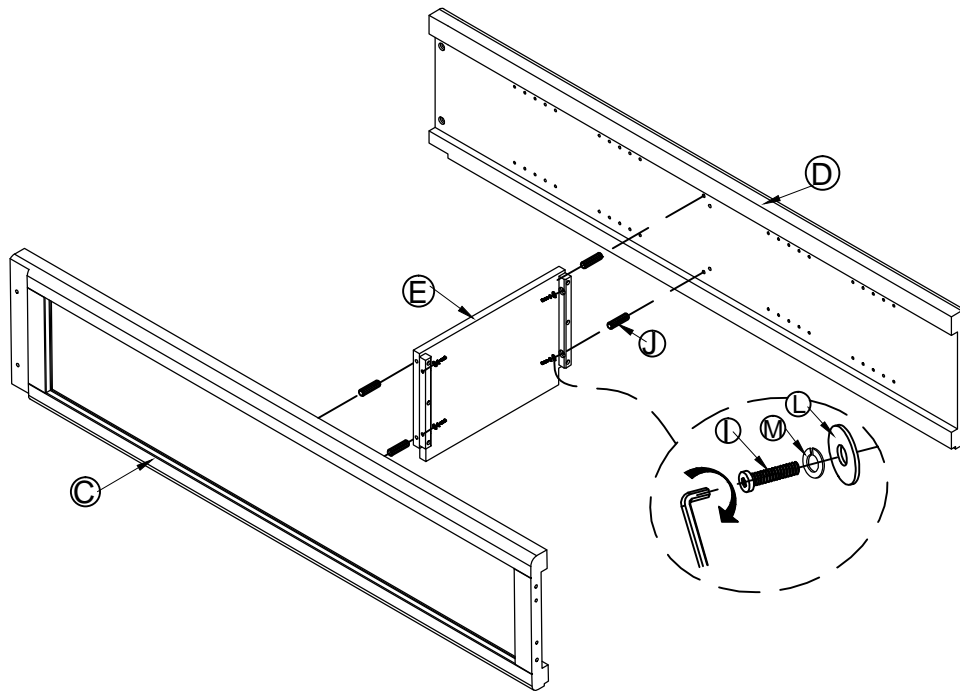

- 1) . JOIN THE SHELF(E) TO THE LEFT SIDE PANEL(C) AND RIGHT SIDE PANEL(D) BY USING 4PCS WOOD DOWLS(J),4PCS BOLTS(I),4PCS SPRING WASHER (M) AND 4PCS FLAT WASHER(L).

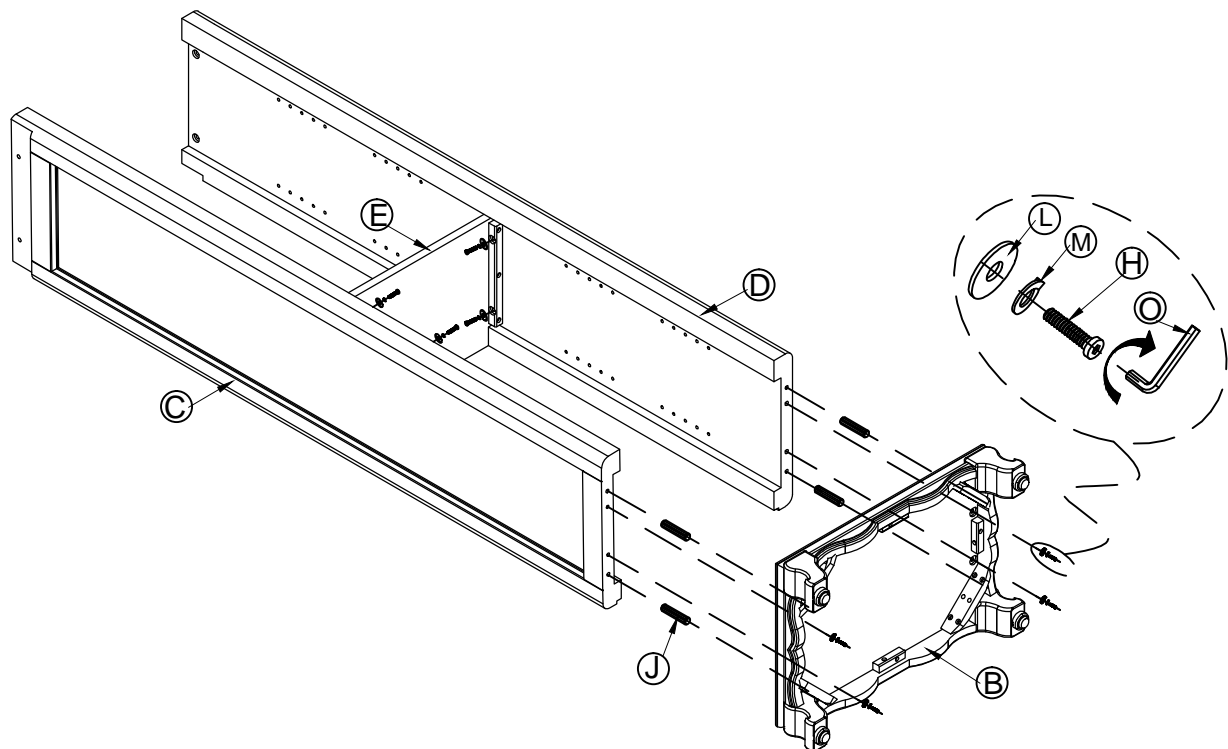

- 2) . JOIN THE BOTTOM PANEL(B) TO THE LEFT SIDE PANEL(C) AND RIGHT SIDE PANEL(D) BY USING 4PCS WOOD DOWLS(J),4PCS BOLTS(H),4PCS SPRING WASHER (M) AND 4PCS FLAT WASHER(L).

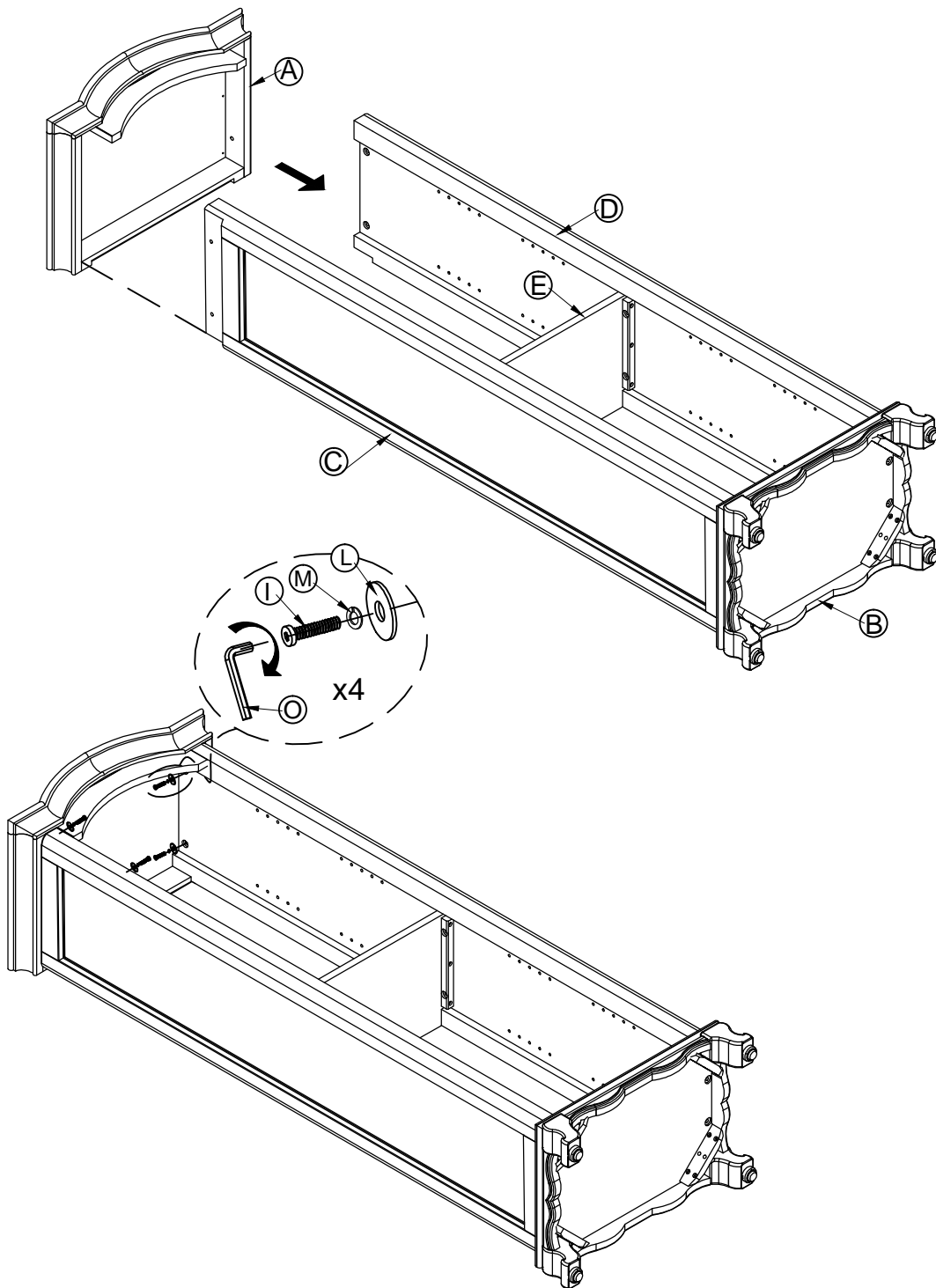

3) . JOIN THE TOP PANEL(A) TO THE LEFT SIDE PANEL(C) AND RIGHT SIDE PANEL (D) BY USING 4PCS BOLTS(I),4PCS SPRING WASHER(M) AND 4PCS FLAT WASHER(L) .

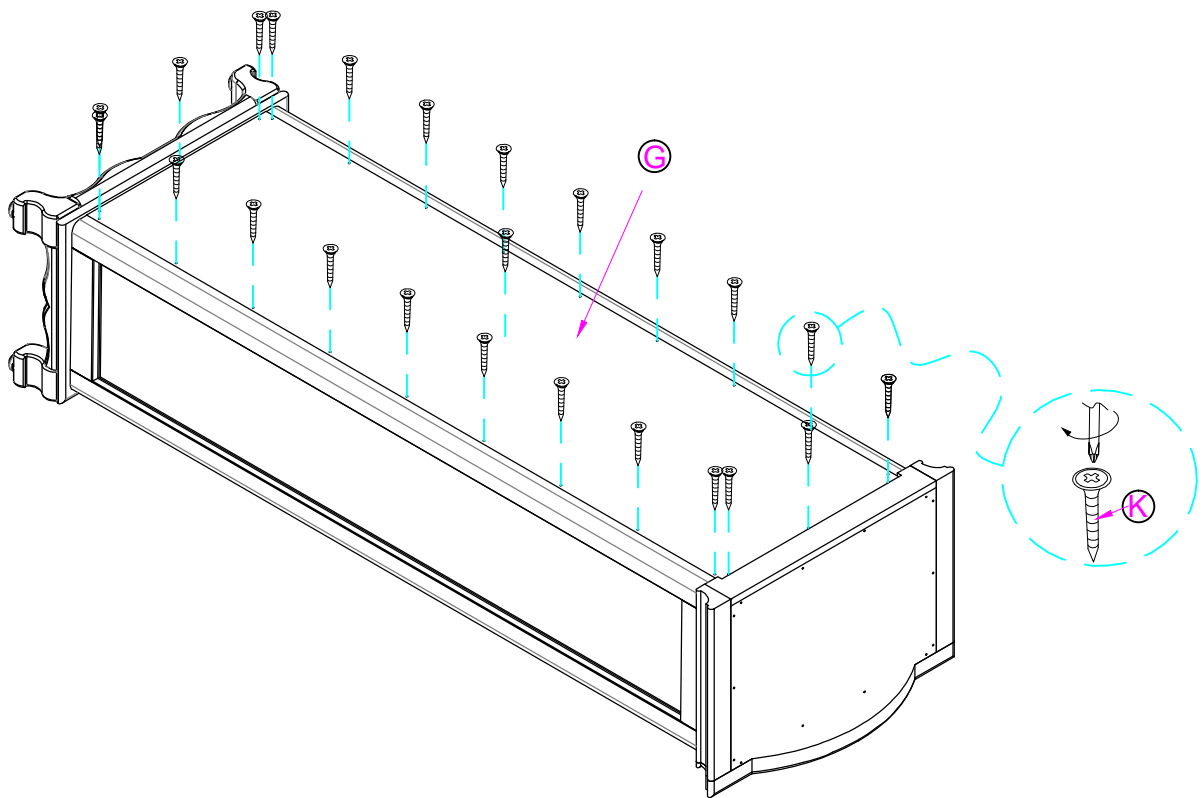

4) . FINALLY JOIN THE BACK PANEL(G) TO THE WHOLE CABINET BY USING 23PCS SCREWS(K).

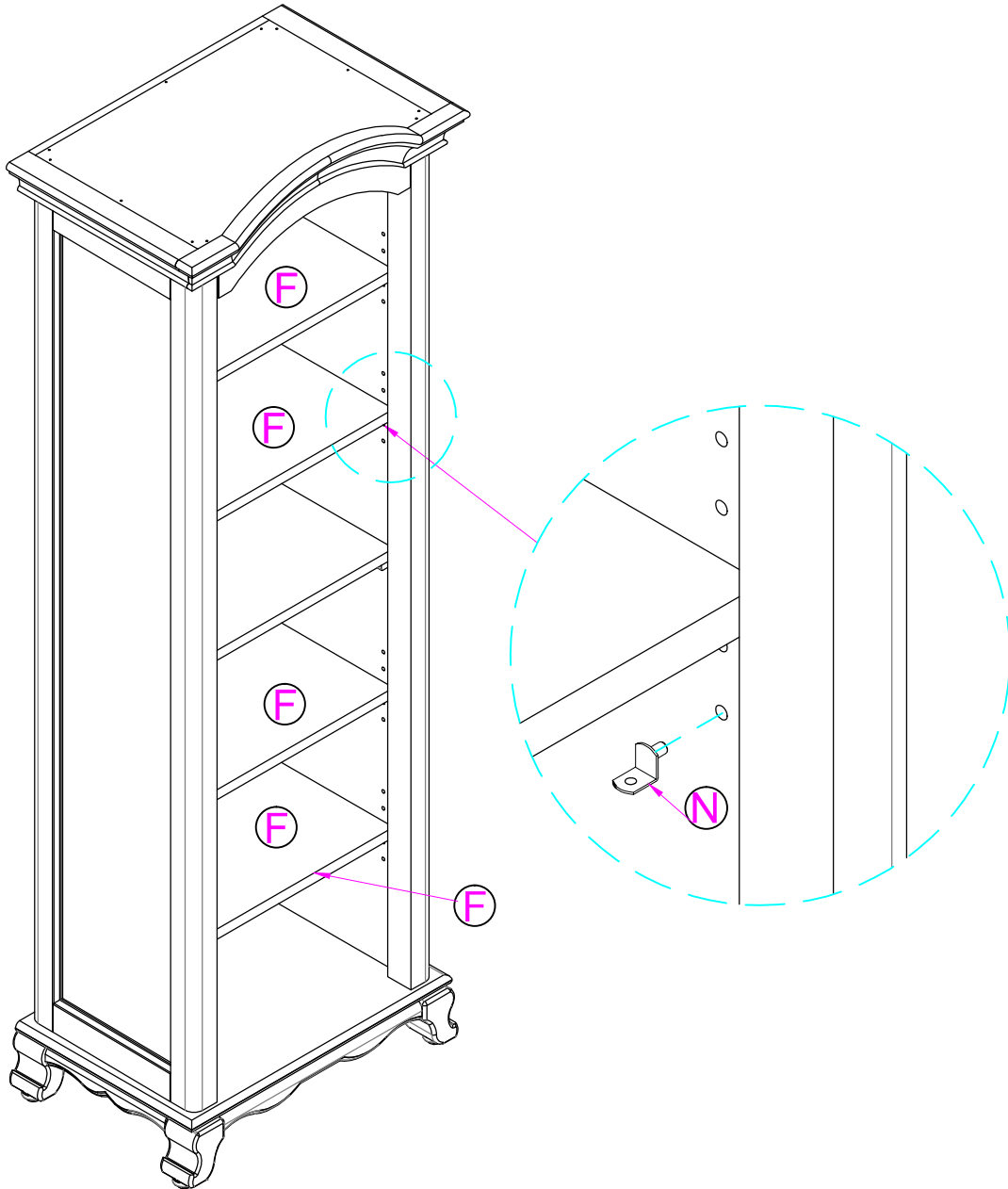

- 5) . PUT THE SHELF HOLDERS (N) INTO THE ADJUSTABLE HOLES.
THEN PLACE THE ADJUSTABLE SHELVES (F) IN THE DESIRED LOCATION.