

# WORKBENCH INSTALLATION INSTRUCTIONS

## IMPORTANT

### PRODUCT LIABILITY INFORMATION

Read all instructions before proceeding with installation or drawer loading. Vital product information pertaining to proper set-up and cautions are included. Failure to follow these instructions may cause failure which may result in personal injury or property damage.

**RETAIN THIS MANUAL FOR FUTURE REFERENCE**

3002 N. Burdick Street

Kalamazoo, MI 49004

t: 800-748-0227 f: 269-342-4161

[www.borroughs.com](http://www.borroughs.com)



## Table of Contents

<b>Before You Begin :</b> . . . . .	<b>3</b>
<b>Basic Workbench :</b> . . . . .	<b>4</b>
<b>Bottom Shelf :</b> . . . . .	<b>11</b>
<b>Footrest :</b> . . . . .	<b>12</b>
<b>Guards :</b> . . . . .	<b>13</b>
<b>Top Shelf :</b> . . . . .	<b>15</b>
<b>Warranty :</b> . . . . .	<b>18</b>



## Before You Begin

1. Check your inventory to be sure you received your entire order; refer to the Parts List on the following pages. If there are any missing or damaged parts, contact the **Borroughs Corporation Customer Service Manager @ 1-800-748-0227**.
2. Read and understand the entire installation instructions prior to beginning the install.
3. Some applications **DO NOT** utilize all the holes in components, or all the fasteners supplied, refer to illustrations for specifics.
4. The estimated time to complete the assembly is **30 minutes** with (2) people.

## Tools Required



**#3 Point Phillips Head  
Screwdriver**



**7-16" (Footrest Only)  
1/2"  
3/4" (Caster Base Only)  
7/8" (Leg Leveler Only)**



**1/4" Diameter Drill Bit  
(Wood Top Only)  
3/8" Diameter Drill Bit  
(Steel Top Only, Top Shelf)**

## Hardware Supplied

**A**

**07792-00**

**Screw 5/16-18 X 1/2**



**B**

**17213-00**

**Nut 5/16-18**

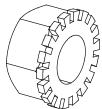

**C**

**100530-00**

**Weldnut 5/16-18**

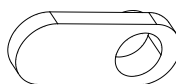

**D**

**41801-00**

**Washer 1/4**



**E**

**07742-00**

**Nut 1/4-20**

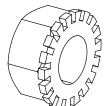

**F**

**07791-00**

**Screw 1/4-20 X 2**



**G**

**07764-00**

**Screw 5/16-18 X 5/8**

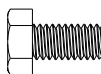

**H**

**07737-00**

**Nut 7/16-14**

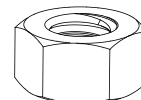

**K**

**07843-00**

**Washer 7/16**



**L**

**11203-01**

**Screw 5/16-18 X 1-1/4**

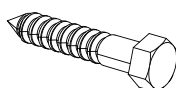

**M**

**07850-00**

**Washer 5/16**



# Basic Workbench

## Parts List

Item	Description	Qty
1	Top (Steel or Wood)	1
2	Stringer	1
3	Leg Channel	2 *
4	Leg Frame	2
5	Leg Foot	4
6	Leg Leveler	4 ***
7	Caster Plate	4 ****
8	Swivel Caster	2 ****
9	Swivel Caster w/Brake	2 ****
	Hardware Bag—Leg Frame (BOR00293-00) Each contains (8) <b>A</b> , (8) <b>B</b> Fasteners	2
	Hardware Bag—Stringer (BOR00664-00) Each contains (8) <b>A</b> , (8) <b>C</b> Fasteners	1
	Hardware Bag—Wood Top (BOR00948-00) Each contains (8) <b>L</b> , (8) <b>M</b> Fasteners	1 **
	Hardware Bag—Leg Leveler (BOR00296-00) Each contains (2) <b>A</b> , (2) <b>B</b> Fasteners	2 ***
	Hardware Bag—Caster Base (BOR00009-00) Each contains (8) <b>A</b> , (8) <b>B</b> , (4) <b>L</b> , (4) <b>M</b> Fasteners	1 ****

\* steel tops only

\*\* wood tops only

\*\*\* leg leveler base only

\*\*\*\* caster base only

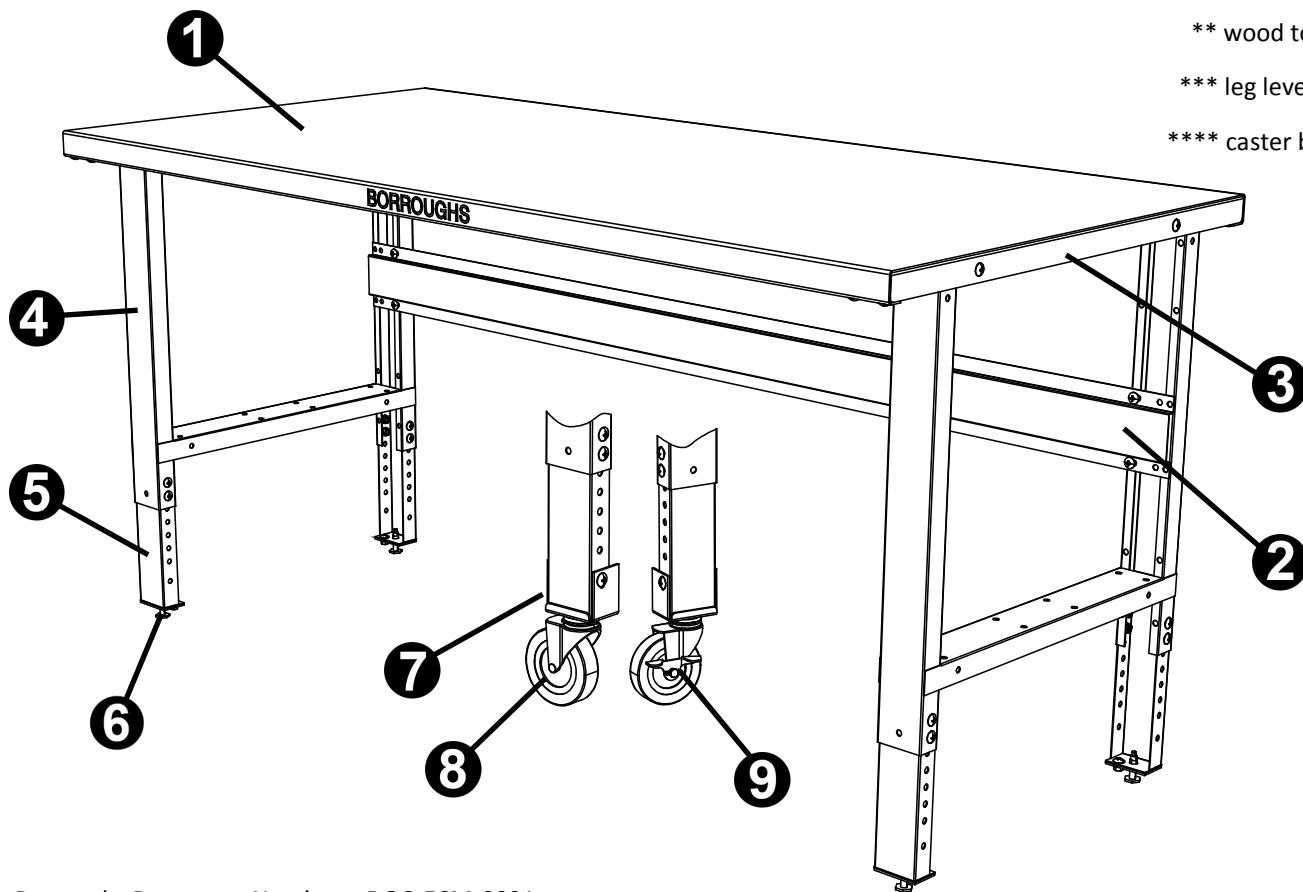

## 1 Stringer to Leg Frames

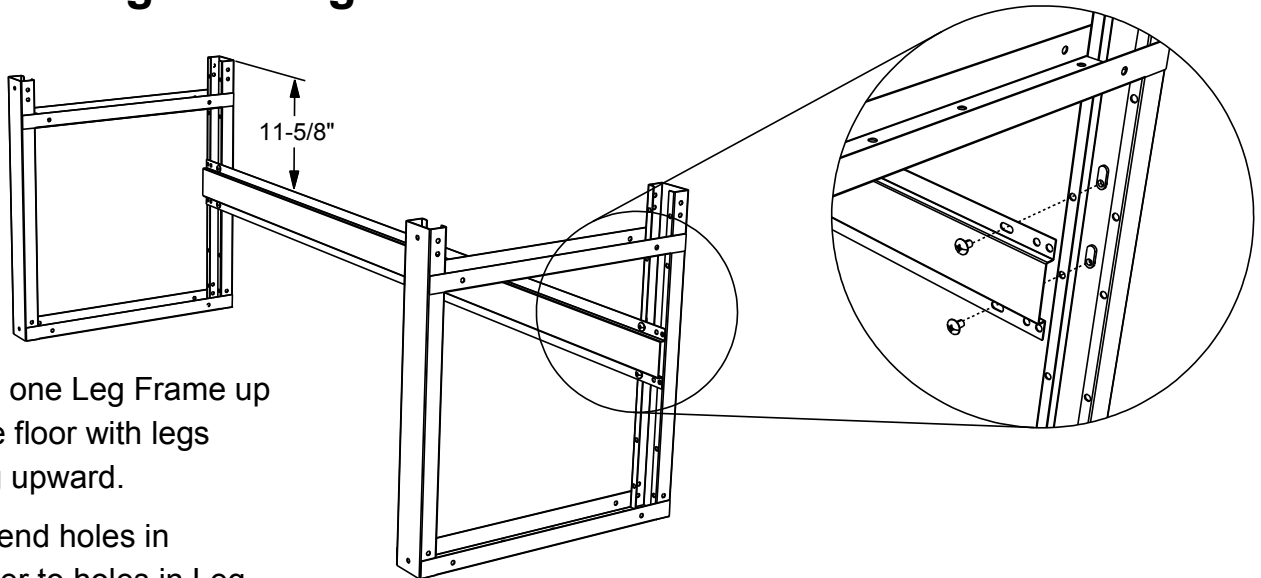

1. Stand one Leg Frame up on the floor with legs facing upward.
2. Align end holes in Stringer to holes in Leg Frame at approximately 11-5/8".
3. Loosely fasten together with (4) **A** screws and (4) **C** weldnuts.
4. Repeat Steps 1-3 to the other leg Frame on opposite end of the Stringer. Tighten all hardware.  
**“NOTE”** - This completes the Leg Frame Assembly.

## 2 Leg Channels to Steel Top (Skip step for wood top)

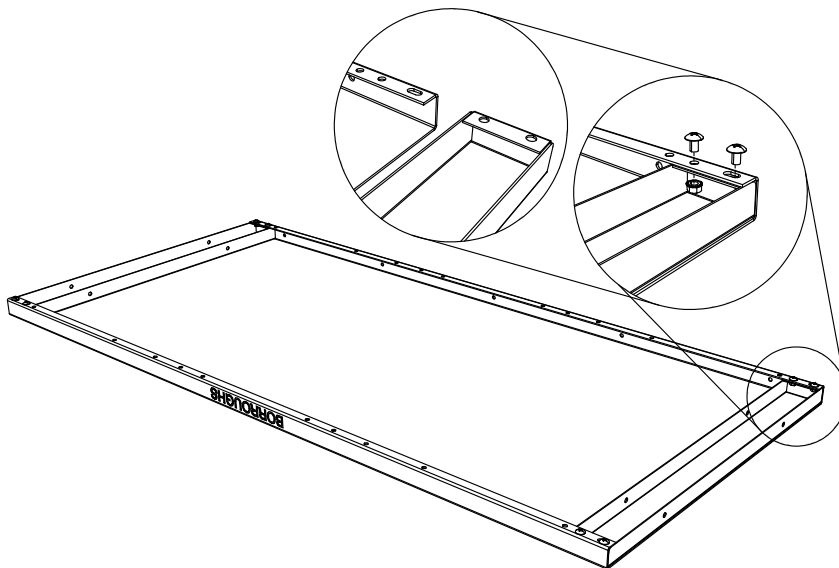

**“NOTE”** - Peel off protective film if stainless tops are being used.

1. Lay Top face-down on flat, clean surface such as a blanket or the cardboard packaging.
2. Insert Leg Channel into end of top with open area of channel facing upward.
3. Align Leg Channel holes with obround and first hole of top flange.
4. Loosely fasten together with (4) **A** screws and (4) **B** Nuts.
5. Repeat steps 2-4 to other Leg Channel on opposite end of top. Tighten all hardware.

## 3 Leg Frame Assembly to Steel Top (Skip step for wood top)

1. Insert Leg Frame Assembly into Leg Channels.

**“NOTE”** - The Stringer should be located on the opposite side to the Borroughs logo that is stamped on the flange of the top.

2. Align Leg Frame Assembly holes with Leg Channel holes.
3. Loosely fasten together with (4) **A** screws and (4) **B** nuts.
4. Repeat Steps 2-3 to the opposite side. Tighten all hardware.

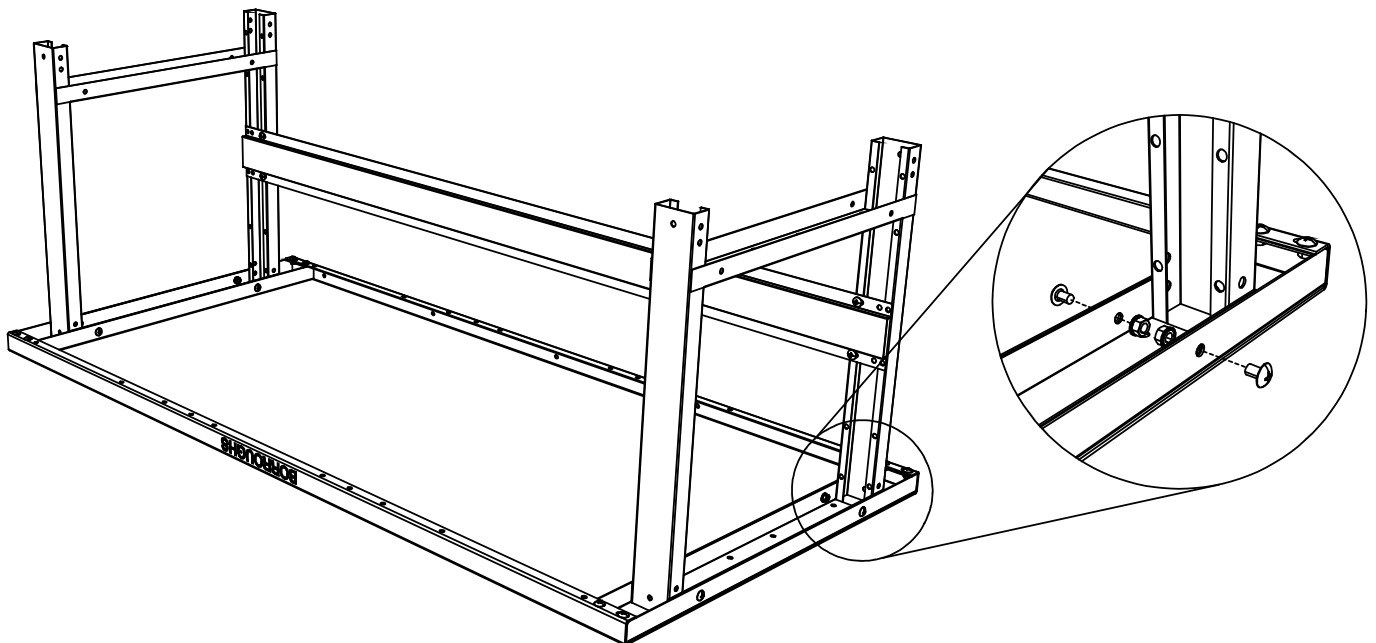
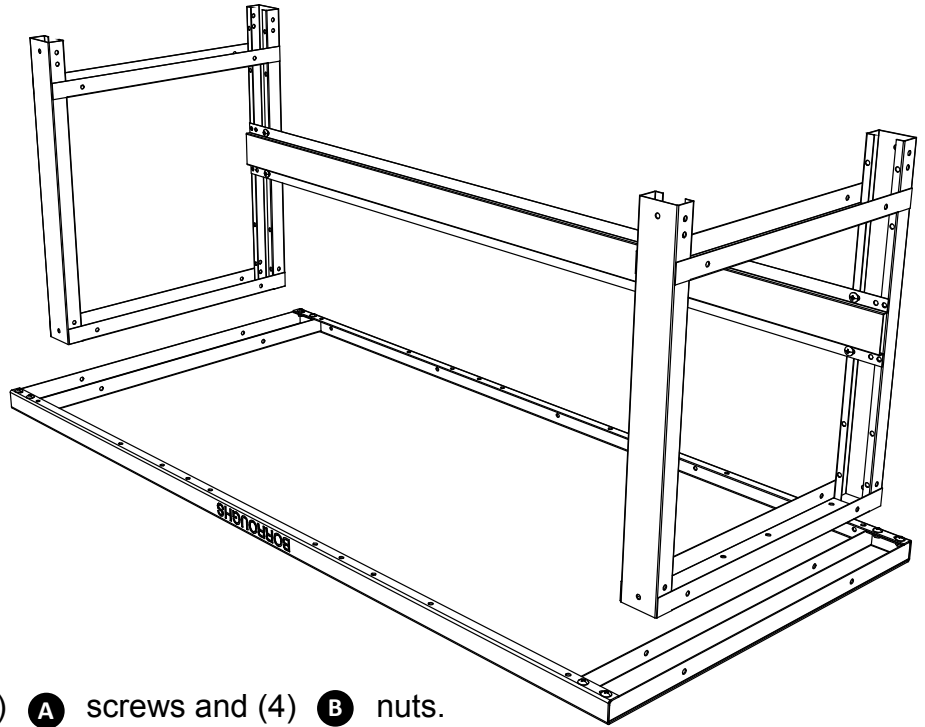

## 4 Leg Frame Assembly to Wood Top (Skip step for steel top)

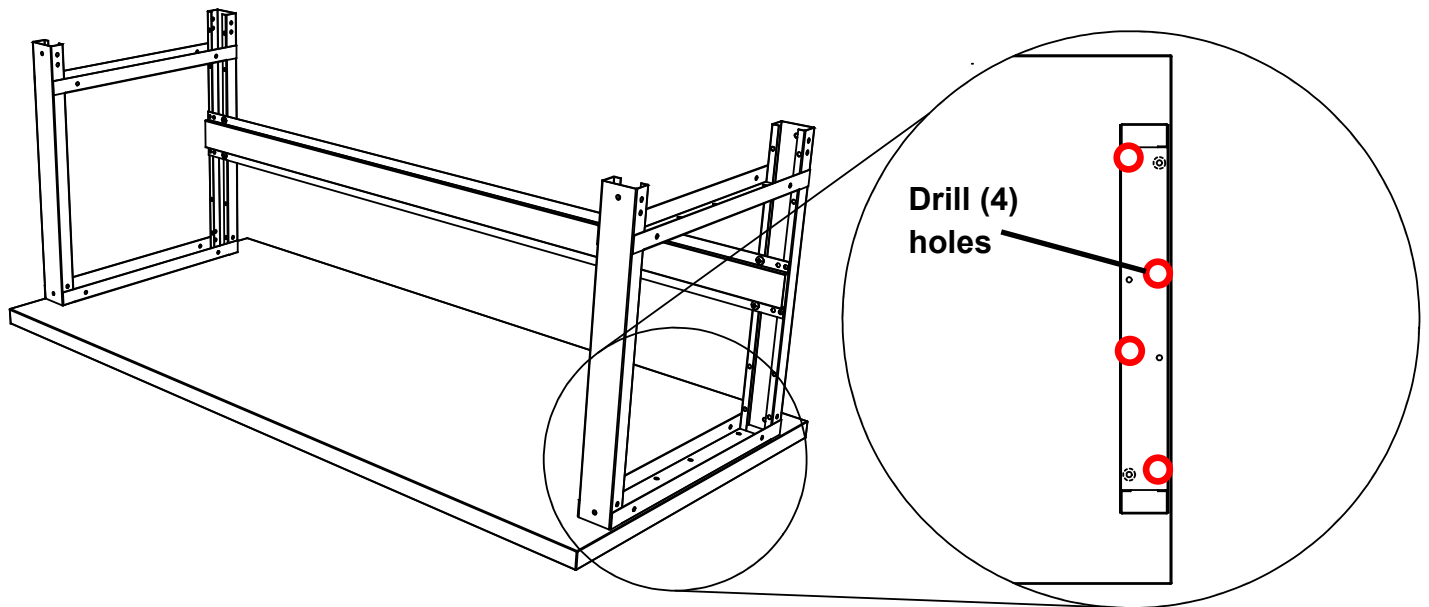

1. Determine best side of Top. Lay that side face-down on flat, clean surface such as a blanket or the cardboard packaging.
2. Locate Leg Frame Assembly onto Wood Top and center right to left and front to back.
3. Use the holes in Leg Frame Assembly as a template to mark on wood top where to drill.

**“NOTE”** - Only (4) of the (8) holes in the Leg Frame Assembly are required for attachment.

4. Drill (8), 1/4” diameter holes 1” deep into the top.
5. Fasten Leg Frame Assembly to the wood top with (8) **L** lag screws and (8) **M** washers.

## 5 Leg Foot Assembly

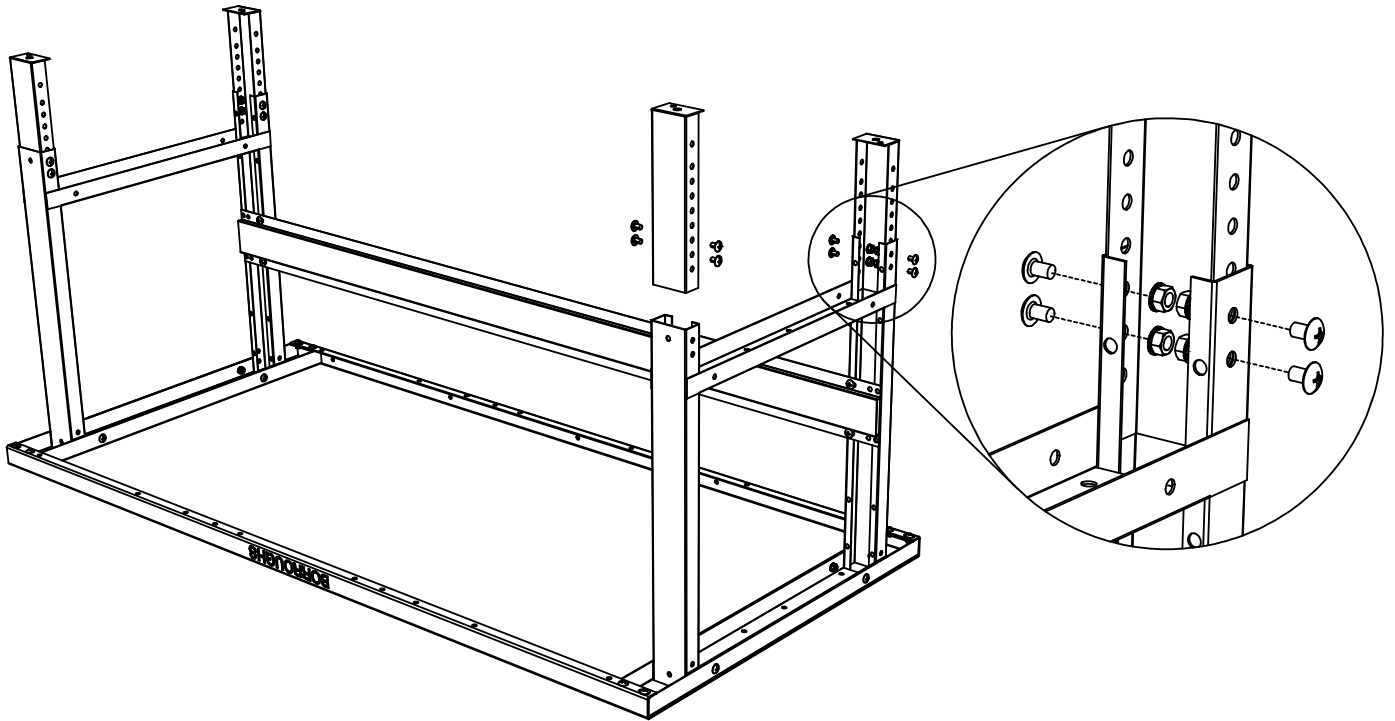

1. Insert Leg Foot into end channel of the Leg Frame Assembly.
2. Align holes to specific level (1" vertical adjustability).

**“NOTE”** - Overall workbench height (min/max)

Steel Top—30-3/4" / 36-3/4"

Wood Top—32-1/4" / 38-1/4"

Add 4-1/4" to dimensions if casters are used.

3. Fasten together with (4) **A** Screws and (4) **B** Nuts.
4. Repeat steps 1-3 to other (3) Leg Feet.



## 6 Leg Leveler Assembly

(Skip step for casters)

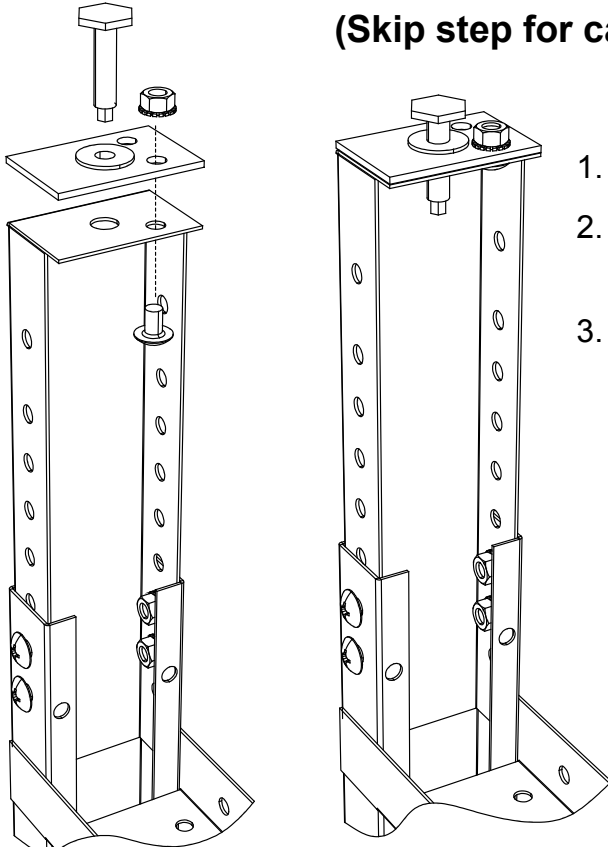

1. Insert Leg Lever into Leg Foot.
2. Align hole and fasten together with (1) **A** Screw and (1) **B** Nut.
3. Repeat steps 1-2 to other (3) Leg Levelers.

## 7 Caster Assembly

(Skip step for casters)

1. Locate Caster Plate over Leg Foot with plate flange to outside of workbench.
2. Align holes and fasten together with (2) **A** Screws and (2) **B** Nuts.
3. Insert the threaded stem of caster through Caster Plate and Leg Foot.
4. Fasten together with (1) **H** Nut and (1) **K** Washer.
5. Repeat Steps 1-4 to other (3) casters.

**“NOTE”** - Casters w/Brakes should be located on the same end of workbench.

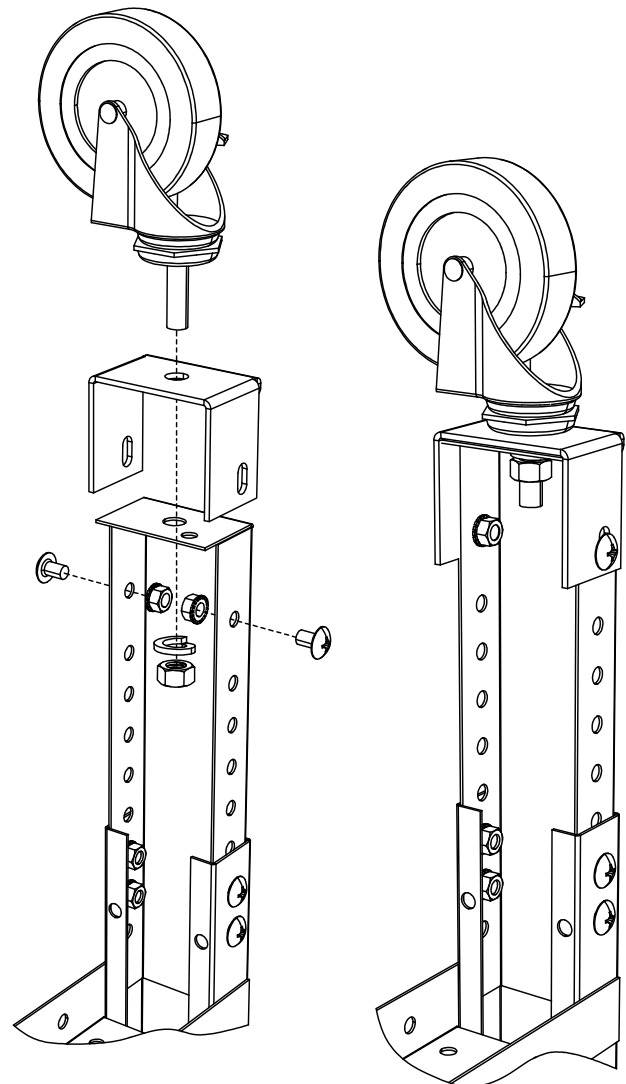

## 8 Final Assembly

1. Ensure all fasteners are properly tightened.

**⚠ CAUTION**

2. Rotate the Workbench to upright position. Requires (2) people. Do not attempt to tip bench on its side with a single person, as it is unstable in this position and may cause harm to you or damage to workbench integrity.
3. Move Workbench to final location. Requires (2) people.
4. If the Workbench utilizes Leg Levelers, make adjustments using a 7/8" wrench to ensure unit is properly leveled.
5. This completes the assembly of the Basic Workbench.

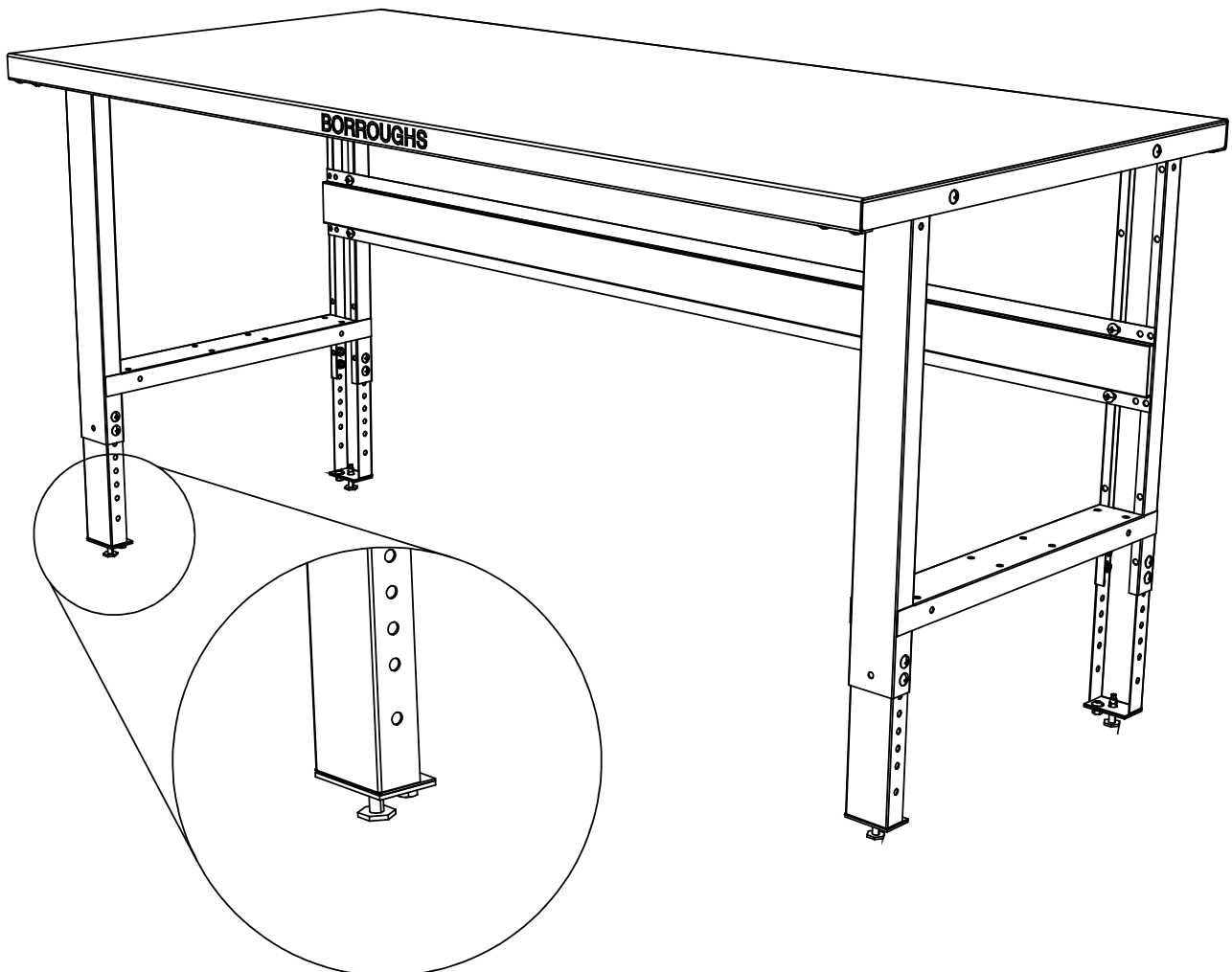

## Bottom Shelf

### Parts List

Item	Description	Qty
1	Bottom Shelf	1
2	Hardware Bag—Shelf (BOR00002-00) Each consists of (4) <b>A</b> , (4) <b>B</b> fasteners	1

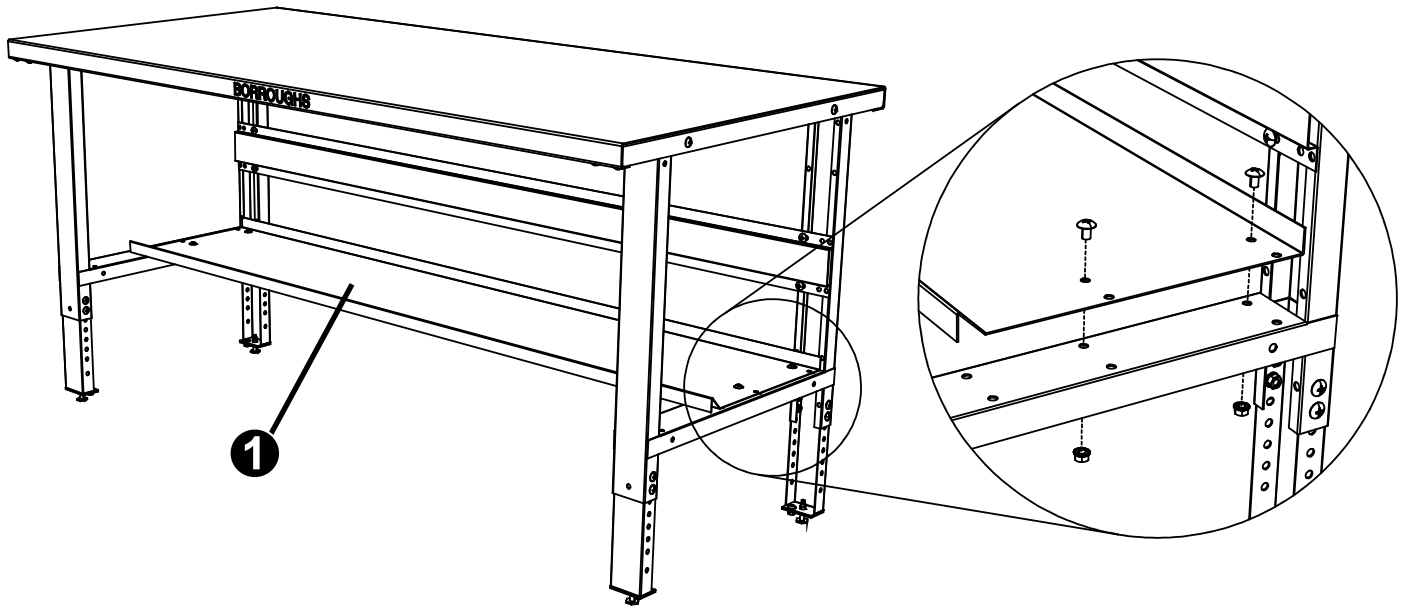

## Bottom Shelf Assembly

1. Position Bottom Shelf over left and right Leg Frames.

“NOTE” - The ninety degree shelf flange is located at the back.

2. Align holes in Bottom Shelf to holes in Leg Frames.
3. Fasten together with (4) **A** screws and (4) **B** nuts.

“NOTE” - Only (4) of the (8) holes in the Bottom Shelf are required for attachment.

**This Completes the Bottom Shelf Assembly**

## Parts List

Item	Description	Qty
1	Footrest	1
2	Hardware Bag—Footrest (BOR865) Each consists of (2) <b>D</b> , (2) <b>E</b> , (2) <b>F</b> fasteners	1

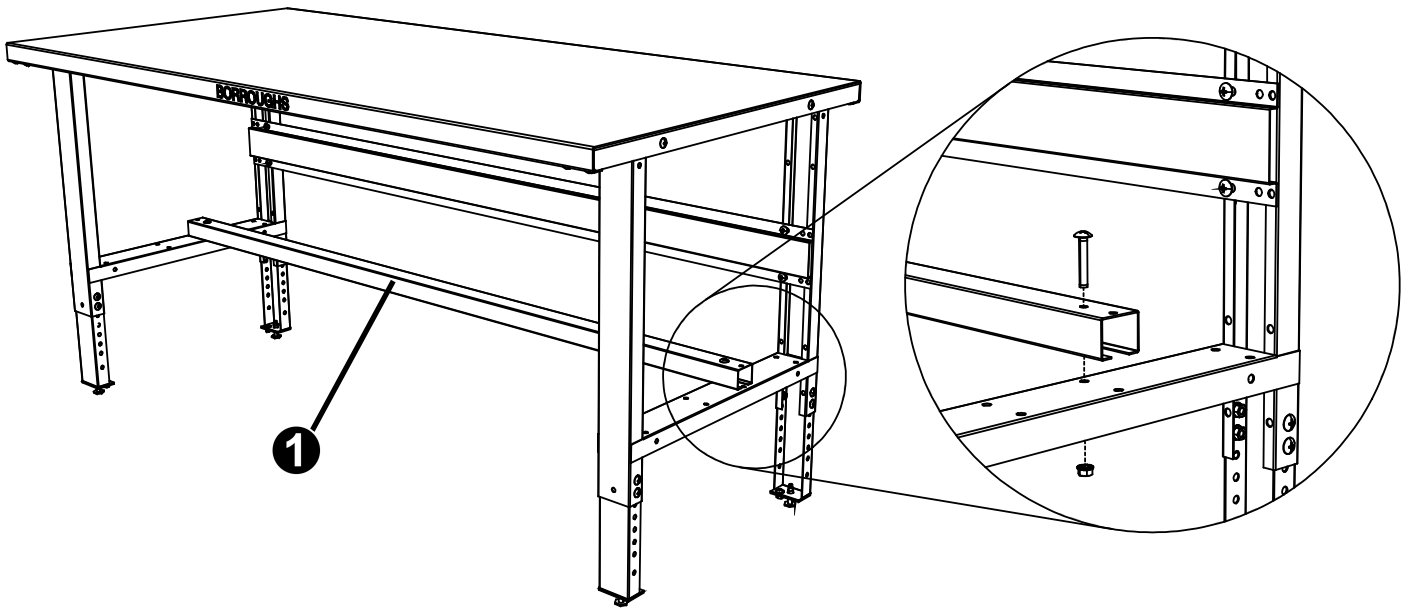

## Footrest Assembly

1. Position Footrest over left and right Leg Frames.
2. Align inner end holes in Footrest to inner holes in Leg Frames.

“NOTE” - Footrests can be located at any one of the four locations in the frame.

3. Fasten together with (2) **F** screws, (2) **D** washers, and (2) **E** nuts.

“NOTE” - Only (2) of the (4) holes in the Footrest are required for attachment.

**This completes the Footrest Assembly**

## Guards

### Parts List

Item	Description	Qty
1	End Guard	2
2	Back Guard	1
3	Hardware Bag—Guards (ECM-0029) Each consists of (11) <b>A</b> , (11) <b>B</b> , (11) <b>L</b> , (11) <b>M</b> fasteners	1

## Guard Assembly (Steel Top)

“NOTE” - Peel off protective film if stainless guards.

1. Align Back Guard holes over holes in back flange of Top.

“NOTE” - Locate end flanges to front of workbench.

2. Loosely fasten together with (5) **A** screws and (5) **B** nuts.

3. Align End Guard holes over holes in side flange of top.

“NOTE” - End Guard overlaps Back Guard flange.

4. Loosely fasten together with (3) **A** screws and (3) **B** nuts.
5. Repeat Steps 3-4 for other End Guard.
6. Ensure Assembly is properly aligned and tighten all hardware.

**This completes the guard assembly.**

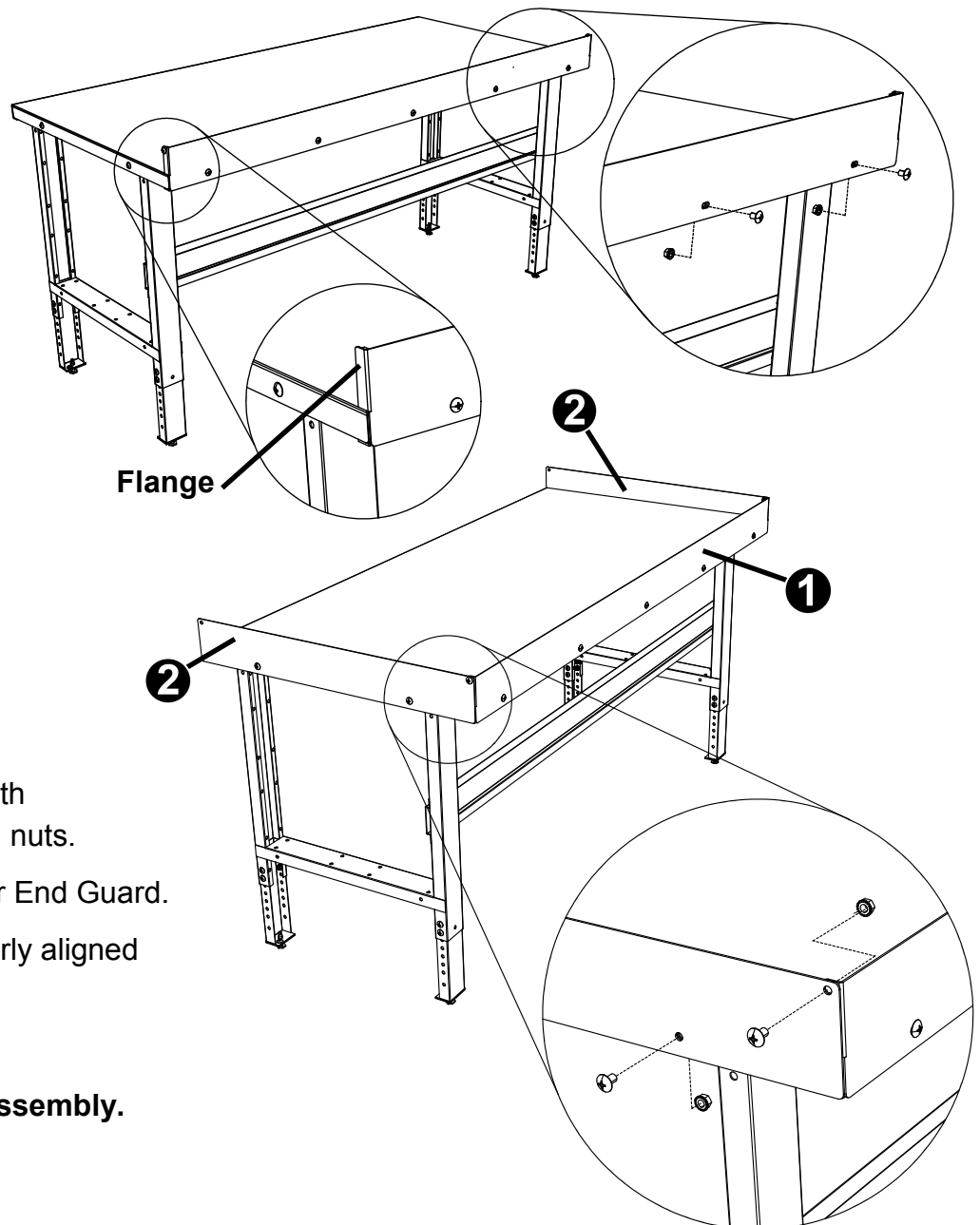

## Guards

### Guard Assembly (Wood Top)

“NOTE” - Peel off protective film if stainless guards.

1. Position Back Guard with its bottom edge flush to bottom edge of wood top.

“NOTE” - locate end flanges to front of workbench.

2. Use the holes in Back Guard as a template to mark on top where to drill.
3. Drill (5), 1/4” diameter holes; 1” deep into top.
4. Loosely fasten together with (5) **L** screws and (5) **M** washers.

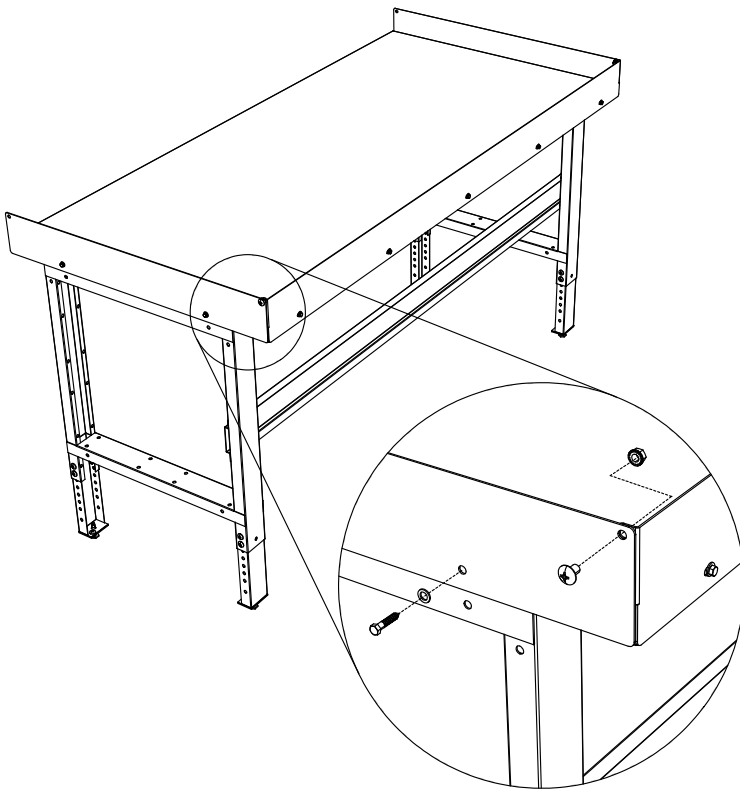
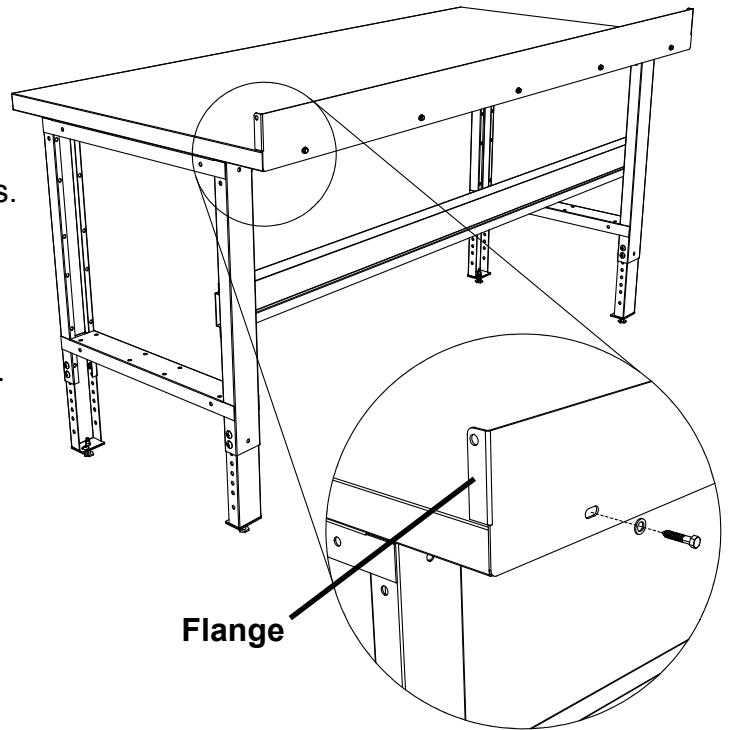

5. Position End Guard with its bottom edge flush to bottom edge of top and align hole with hole in Back Guard.
6. Use holes in the End Guard as a template to mark on top where to drill.
7. Drill (2), 1/4” diameter holes; 1” deep into top.
8. Loosely fasten together with (2) **L** screws, (2) **M** washers, (1) **A** screw, and (1) **B** nut.
9. Repeat steps 5-8 to install other End Guard.
10. Ensure Assembly is properly aligned and tighten all hardware.

**This completes the Guard assembly.**

## Top Shelf

### Parts List

Item	Description	Qty
1	Top Shelf	1
2	End Panel	2
3	Hardware Bag—Top Shelf (ECM-0031) each consists of (10) <b>A</b> , (10) <b>B</b> , (4) <b>L</b> , (4) <b>M</b> fasteners	1

## Top Shelf Assembly

1. Position Top Shelf on workbench so that one end is overhanging.
2. Position End Panel outside the over hanging Shelf and align the holes.
3. Loosely fasten together with (3) **A** screws and (3) **B** nuts.
4. Repeat steps 1-3 for other End Panel.
5. Ensure assembly is properly aligned and tighten all hardware.

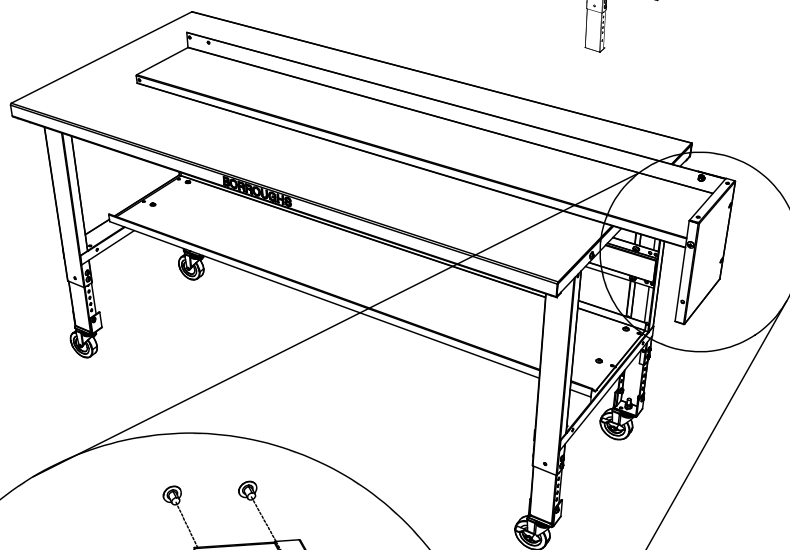
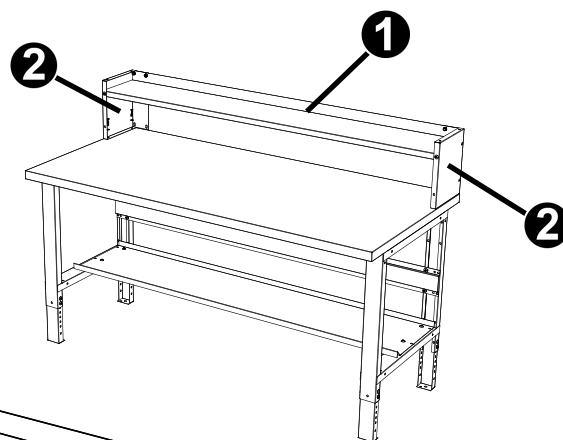

**This completes Top Shelf Sub- Assembly.**

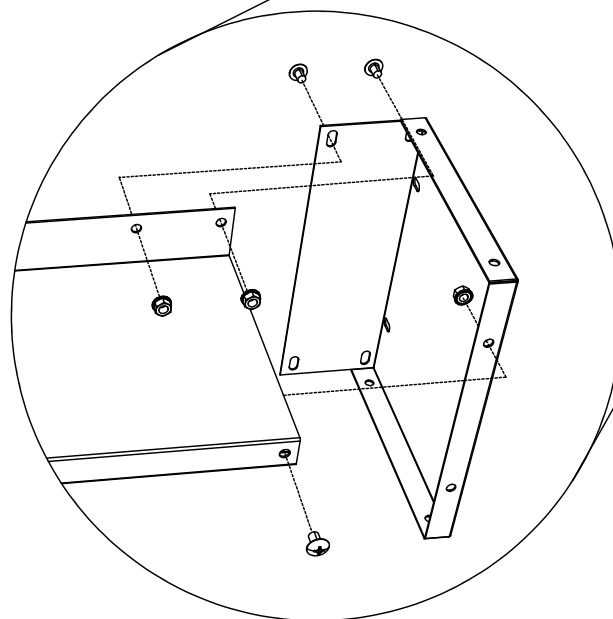



## Top Shelf Assembly (Steel Top)

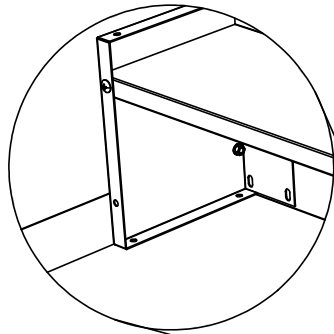

1. If workbench features Guards, remove fasteners that joins their corners together (both sides).
2. Position Top Shelf Assembly flush against back and sides of the top.

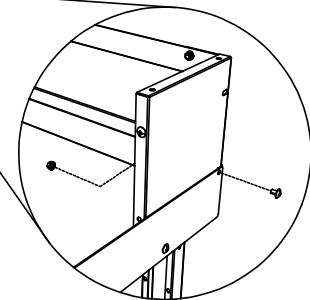
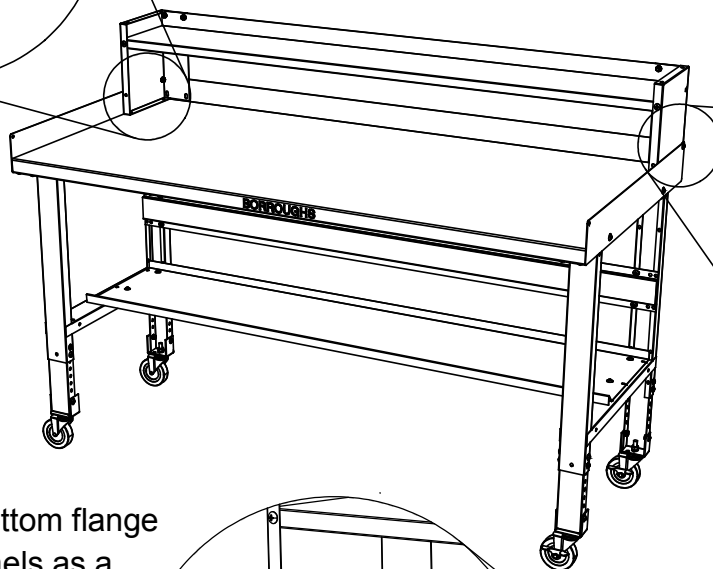

3. Use holes in bottom flange of both end panels as a template to mark on top where to drill.
4. Set Top Shelf Sub-Assembly aside to provide space for drilling.
5. Drill (4), 3/8" diameter holes through top and frame (both sides).
6. Reposition Top Shelf Sub-Assembly and fasten into place using (4) **A** screws and (4) **B** nuts.

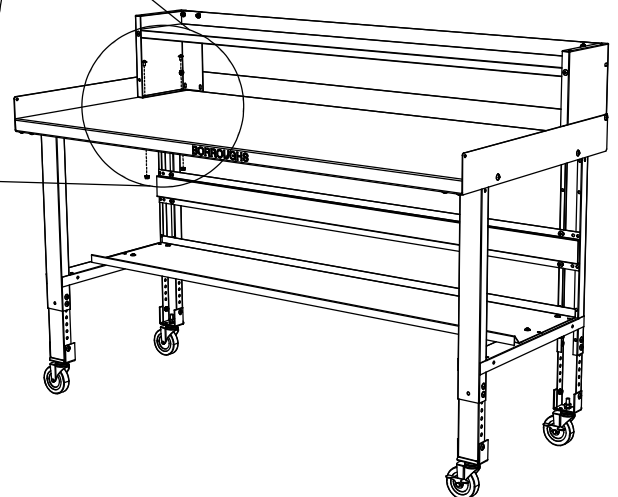
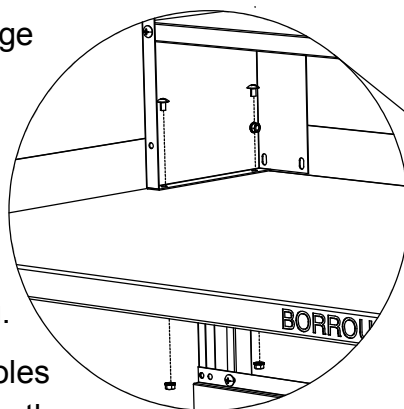

**This completes top shelf assembly for steel tops.**



## Top Shelf Assembly (Wood Top)

1. If workbench features Guards, remove fasteners that joins their corners together (both sides).
2. Position Top Shelf Assembly flush against back and sides of top.
3. Use holes in bottom flange of both end panels as a template to mark on top where to drill.
4. Set Top Shelf Sub Assembly aside to provide space for drilling.
5. Drill (4), 1/4" diameter holes; 1" deep through top (2 per side).
6. Reposition Top Shelf Sub Assembly and fasten into place using (4) **L** screws and (4) **M** washers.

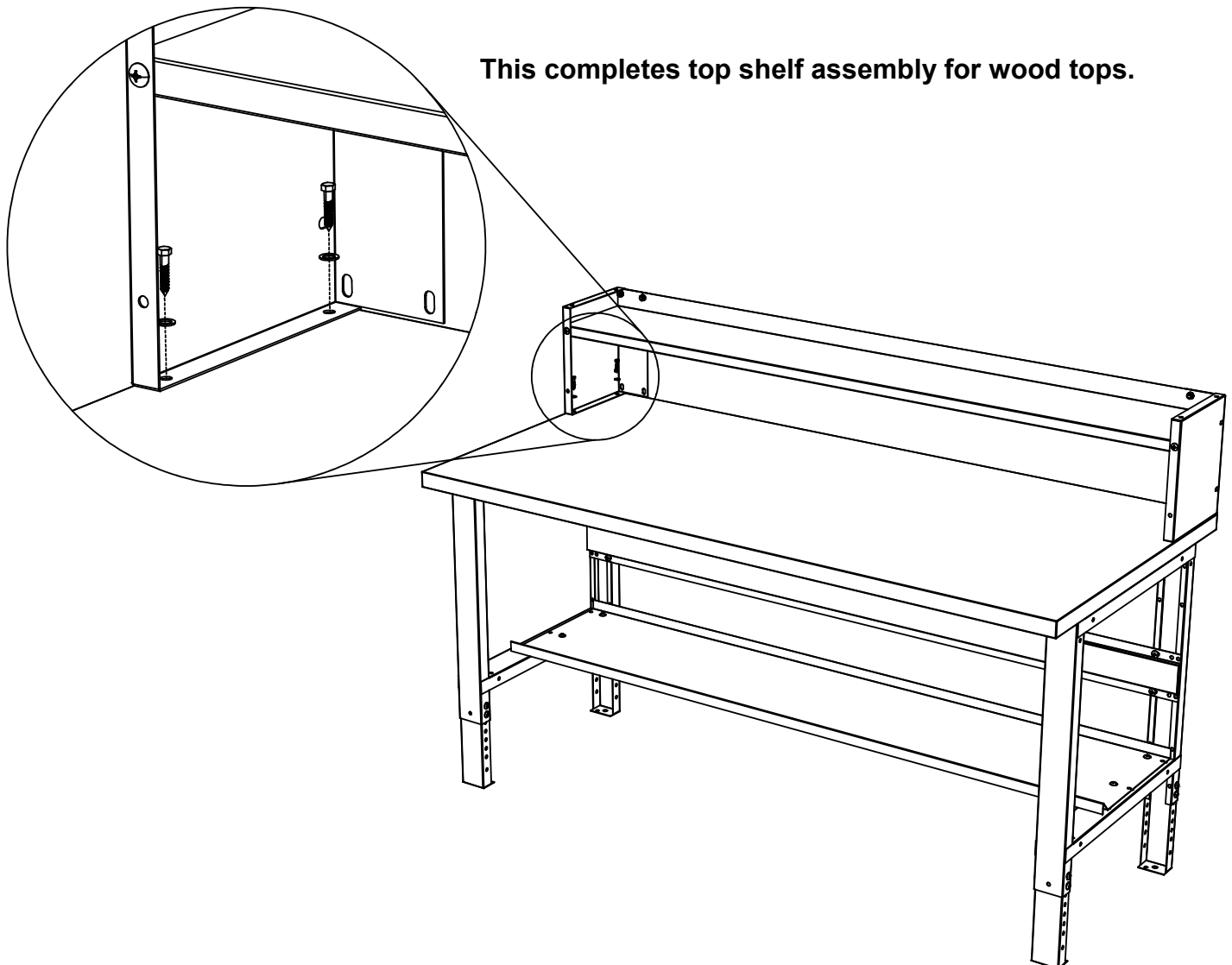



## Warranty Information

### Warranty

Borroughs Corporation extends to the original purchaser from the date of purchase, a 5-year limited warranty against manufacturing defects in material and workmanship. If a Borroughs product fails to perform because of a manufacturing defect, Borroughs will examine it. If found defective, it will be repaired or replaced at our option. This warranty applies only to Borroughs products acquired directly from Borroughs Corporation or from an authorized Borroughs Distributor.

This warranty does not apply to any product which has been subject to misuse, negligence, or accident; has been damaged in shipment, storage, or installation; has been misapplied or has been modified or repaired by unauthorized persons or been repaired with non-standard Borroughs replacement parts. This warranty specifically excludes claims for indirect, incidental, or consequential damages arising in any way from a product defect. This warranty is exclusive, and exists in lieu of all other warranties, either expressed or implied.

This warranty gives you specific legal rights; you may also have other rights which may vary from state to state. Contact your Borroughs Distributor to obtain warranty service. You must make a written claim. Provide a copy of your purchase record and a written description of the warranty problem with your claim.

If you are unable to contact your Distributor, contact:

**Borroughs Corporation, Customer Service Manager,  
3002 N. Burdick St., Kalamazoo, MI 49004-3483.  
Phone: 1-800-748-0227**