

# USE AND CARE GUIDE

---

## LED SECURITY LIGHT DUSK TO DAWN

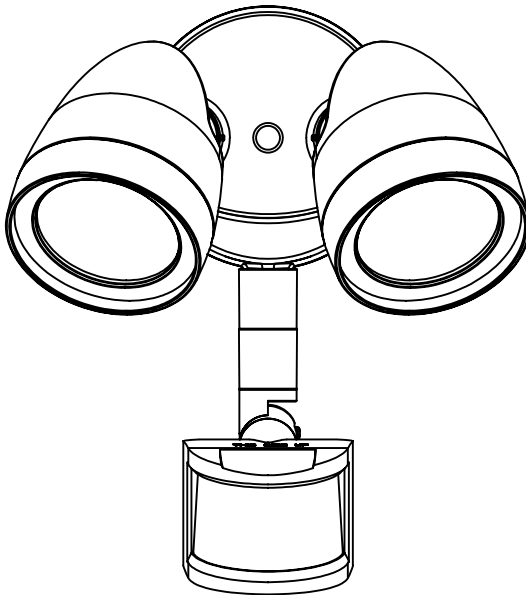

Questions, problems, missing parts?  
Call ETiSSL Customer Service  
8 a.m. - 5 p.m., CST, Monday - Friday  
1-855-ETi-SSLI (1-855-384-7754)

[www.ETiSSL.com](http://www.ETiSSL.com)



---

### THANK YOU

*We appreciate the trust and confidence you have placed in ETI through the purchase of this LED light.  
Visit us online to see our full line of products. Thank you for choosing ETI!*



# Table of Contents

Table of Contents .....	3	Hardware Included.....	4
Safety Information .....	3	Installation .....	5
Warranty .....	3	Maintenance .....	7
Pre-Installation .....	4	Light Distribution .....	7
Planning Installation .....	4	PIR Sensor Testing.....	8
Tools Required .....	4	Care & Cleaning .....	11
Package Contents .....	4	Troubleshooting .....	11

## Safety Information



**WARNING:** Carefully read and understand the information given in this manual before beginning the assembly and installation. Failure to do so could lead to electric shock, fire, or other injuries which could be hazardous or even fatal.



**WARNING:** Ensure the electricity to the wires you are working on is shut off. Either remove the fuse or turn off the circuit breaker.



**WARNING:** Changes or modifications not expressly approved by the party responsible for compliance could void the use authority to operate the equipment.

**NOTICE:** This equipment has been tested and found to comply with the limits for a Class B digital device, pursuant to Part 15 of the FCC Rules. These limits are designed to provide reasonable protection against harmful interference in a residential installation.

This equipment generates, uses and can radiate radio frequency energy and, if not installed and used in accordance with the instructions, may cause harmful interference to radio communications.

However, there is no guarantee that interference will not occur in a particular installation. If this equipment does cause harmful interference to radio or television reception, which can be determined by turning the equipment off and on, the user is encouraged to try to correct the interference by one or more of the following measures:

- Reorient or relocate the receiving antenna.
- Increase the separation between the equipment and the receiver.
- Connect the equipment into an outlet on a circuit different from that to which the receiver is connected.
- Consult the dealer or an experienced radio/TV technician for help.

## Warranty

### WHAT IS COVERED

The manufacturer warrants this lighting fixture to be free from defects in materials and workmanship for a period of five (5) years from date of purchase. This warranty applies only to the original consumer purchaser and only to products used in normal use and service. If this product is found to be defective, the manufacturer's only obligation, and your exclusive remedy, is the repair or replacement of the product at the manufacturer's discretion, provided that the product has not been damaged through misuse, abuse, accident, modifications, alterations, neglect, or mishandling.

### WHAT IS NOT COVERED

This warranty shall not apply to any product that is found to have been improperly installed, set-up, or used in any way not in accordance with the instructions supplied with the product. This warranty shall not apply to a failure of the product as a result of an accident, misuse, abuse, negligence, alteration, faulty installation, or any other failure not relating to faulty material or workmanship. This warranty shall not apply to the finish on any portion of the product, such as surface and/or weathering, as this is considered normal wear and tear.

The manufacturer does not warrant and specifically disclaims any warranty, whether express or implied, of fitness for a particular purpose, other than the warranty contained herein. The manufacturer specifically disclaims any liability and shall not be liable for any consequential or incidental loss or damage, including but not limited to any labor / expense costs involved in the replacement or repair of said product.

Contact the Customer Service Team at 1-855-384-7754 or visit [www.ETISSL.com](http://www.ETISSL.com).

# Pre-Installation

## PLANNING INSTALLATION

Before beginning assembly, installation, or operation of the product, make sure all parts are present. Compare parts with package contents list and hardware contents list above. If any part is missing or damaged, do not attempt to assemble, install, or operate the product. Contact Customer Service for replacement parts.

This light fixture is suitable for wall mounting or eave mounting only. It is not suitable for ground mounting installation. The light fixture should be mounted a minimum of 6.5 ft. (2.0 m) above the ground. If two walls intersect, the distance between the intersecting line and the light fixture should be more than 2 ft. (0.6 m).



**NOTE:** Keep your receipt and these instructions for proof of purchase.

If you are unfamiliar with electrical installations, we recommend you contact a qualified electrician to do the installation.

## TOOLS REQUIRED

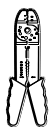

Wire Strippers



Safety Goggles



Ladder



Silicone Sealant



Philips Screwdriver



Electrical Tape



Wire Cutters



Gloves

## PACKAGE CONTENTS

Part	Description	Quantity
A	Light Head	2
B	Light Fixture Base	1
C	PIR Sensor	1

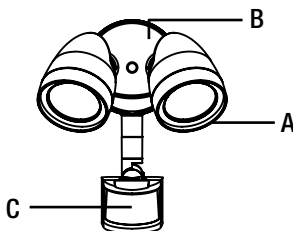

## HARDWARE INCLUDED



**NOTE:** Hardware not shown to actual size.

Part	Description	Quantity
AA	Mounting Screw (long)	1
BB	Mounting Screw (short)	2
CC	Grounding Screw (green)	1
DD	Rubber Plug	1
EE	Wire Connector	3
FF	Mounting Bracket	1
GG	Foam Gasket	1

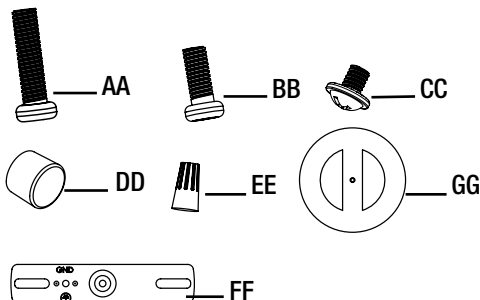

# Installation



**WARNING: RISK OF ELECTRIC SHOCK.** Ensure the electricity to the wires you are working on is shut off. Either remove the fuse or turn off the circuit breaker before removing the existing light fixture or installing the new one.

With power disconnected to the electrical box, remove the existing fixture. Make a sketch of how the current fixture is wired (by wire color) or mark the wires with masking tape and a pencil so you will know how to properly reconnect the wires to the new LED light fixture.

## 1 Attaching the mounting bracket to the electrical box

- Attach the mounting bracket (FF) to the electrical box using the two short mounting screws (BB). The stamped word “GND” faces away from the electrical box during the installation.

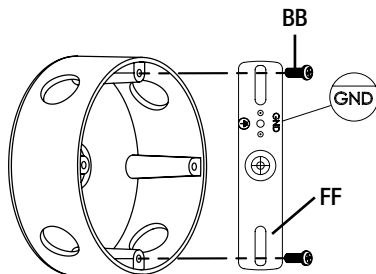

## 2 Attaching the foam gasket to the electrical box

- Position the foam gasket (GG) between the electrical box and the back of the light fixture base (B) to create a weathertight seal.
- Pull the wires from the electrical box through one of the two openings in the foam gasket (GG).

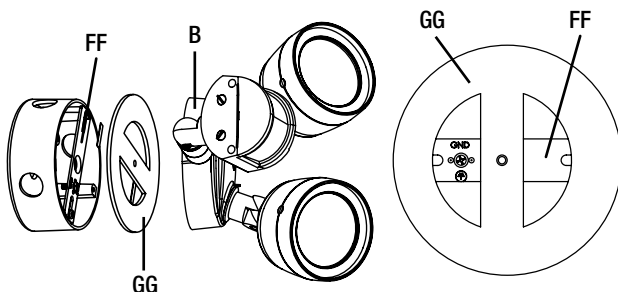

## 3 Making the electrical connections

- Connect the hot and neutral (black and white) wires from the light fixture base (B) to the same color wires from the electrical box.
- Connect the ground wire from the light fixture base (B) to the ground wire from the electrical box, then attach the ground wire to the grounding screw (CC) on the mounting bracket (GG).
- Cover the wire connections using the wire connectors (EE).

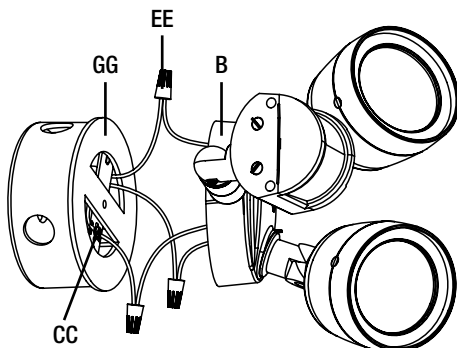

## Installation (continued)

### 4 Attaching the light fixture to the mounting bracket

- Install the light fixture base (B) to the mounting bracket (FF) using the long mounting screw (AA) provided, making sure no wires are visible outside the light fixture.
- Insert the rubber plug (DD) into the hole on the light fixture base (B) for a finished appearance.

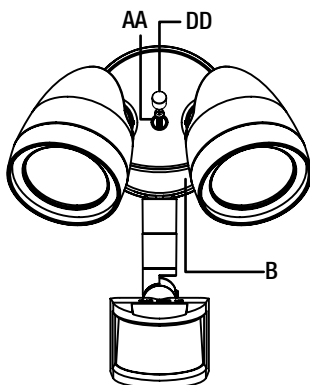

### 5 Sealing the light fixture

- Apply silicone sealant (not included) to the edges of the light fixture base (B) so that the fixture can be completely waterproof and dustproof.

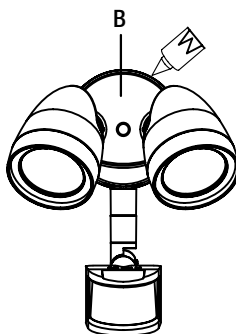

### 6 Adjusting the light heads

- Move each light head (A) into the desired position with your hand, as needed.



**NOTE:** If mounted with the photocell sensor in the down position, the angle between the light head and the wall should be larger than 45° for best performance.



**NOTE:** As an option, the light fixture can be installed with the photocell sensor positioned at the top of the security light.

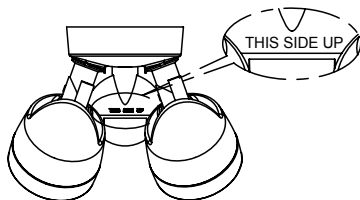
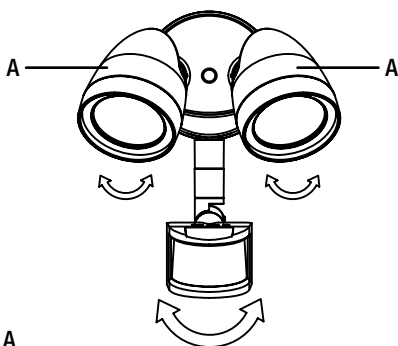
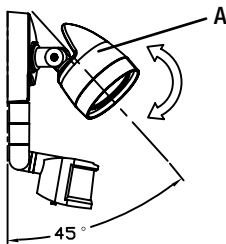
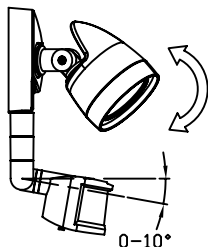

# Maintenance

## To replace the photocell

- Remove the rubber plug (DD) and long mounting screw (AA) from the light fixture base (B).
- Unscrew the two wire connectors (EE) to disconnect the photocell (C).
- Replace with a new photocell (Model # EP-120R or equivalent) using the same two wire connectors (EE).

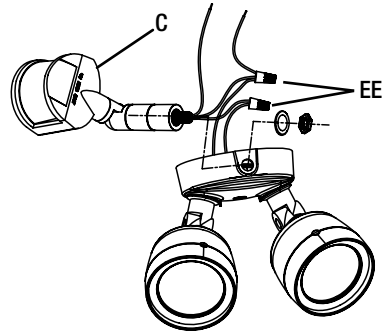
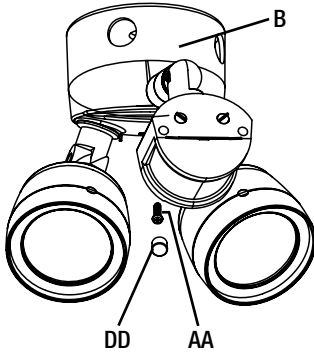

# Light Distribution

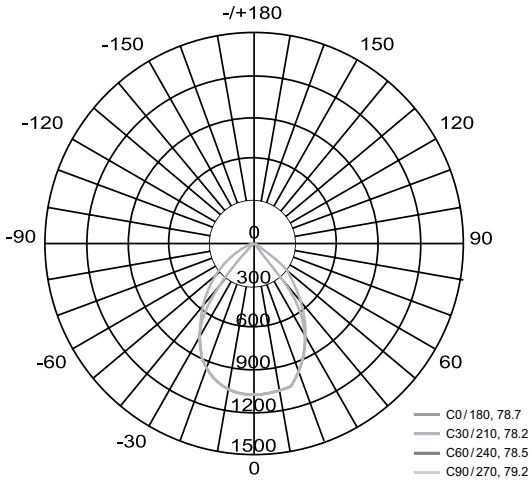

AVERAGE BEAM ANGLE (50%) : 78.7 DEG

# PIR Sensor Testing

## 1 Lighting the product and preheat

- When power is first applied, the light will turn on immediately. Waiting for 20 seconds to allow the sensor to warm up.

## 2 Test Mode

- The motion sensor must be tested before setting the time and sensitivity levels. The TEST option is located on the TIMER control knob on the underside of the sensor head. To test the fixture, switch the wall switch that controls power to the fixture to the ON position and turn the rotary knob to the "TEST" area. During test mode, the lights will come on for 20 seconds, regardless of motion detection or the time of day. The light will shut off automatically after 20 seconds. Leave the rotary knob in the "TEST" area and test the sensitivity by crossing in the path of the sensor. The light will come on only if it senses movement. Once movement stops, it will turn off in 5 seconds. The test is now complete.

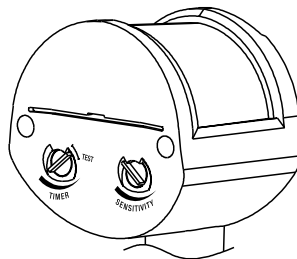

## 3 Sensitivity Set-up

- The control knob located on the opposite side is Marked SENSITIVITY, which determines the degree of Motion detection. Rotating this knob clockwise raises the sensitivity of the motion sensor for up to 60 ft. of distance. Rotating the knob counterclockwise lowers the sensitivity down to as close as 5 ft. It may be necessary to adjust the "SENSITIVITY" knob several times until the desired setting is achieved. NOTE: The higher sensitivity level increases the Likelihood of a false activation being triggered.
- When selecting a location, be aware that the motion sensor is more sensitive to movement across its coverage area and less sensitive to movement toward or away from the motion sensor (Fig.1).

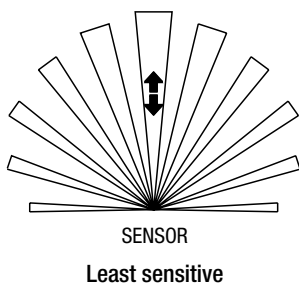
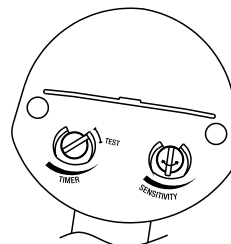
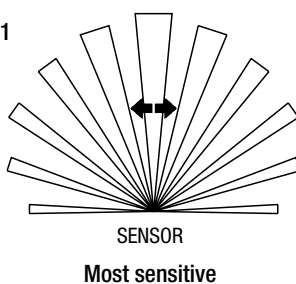

Fig.1





# PIR Sensor Testing (continued)

## 4 1. Auto Mode Set-up

- Once the fixture has been tested for proper operation and sensitivity, rotate the TIMER control knob past the “TEST” setting into the timer settings. The timer settings indicate how long the light stays on after the PIR senses motion.

## 2. Auto Mode Operating

- Rotate the TIMER control knob past the “TEST” setting into the timer settings. The timer settings indicate how long the light stays on after the PIR senses motion. Rotating this knob clockwise raises the stay on time of the motion sensor for up to 5minutes. Rotating the knob counterclockwise shorten the stay on time to as close as 10seconds (can’t past test position). It may be necessary to adjust the TIMER knob several times until the desired ON time is achieved.

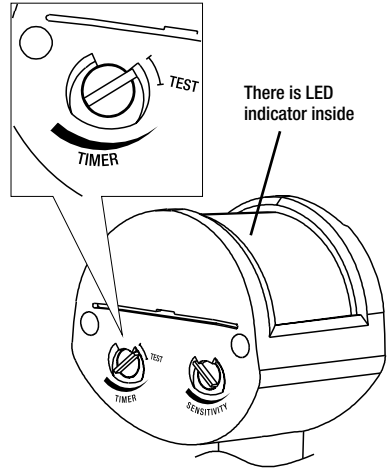

## 5 Manual Override Mode (8-hours auto Rest)

- To shift to the manual override mode, set the VR knob to “AUTO” mode. Turn the wall switch “OFF” and then turn it “ON” within 2 seconds.
- To shift back to the “AUTO” mode, turn the wall switch “OFF” and then turn it “ON” within 2 seconds again.
- The light will turn off automatically at dawn.

## PIR Sensor Testing (continued)

### 6 Troubleshooting

- Extremely hot or cold weather could affect the performance of the built-in sensor that detect body heat. Certain winter clothing can shield a person's body heat from the sensor during extremely cold weather. During extremely hot weather, the sensor may not be able to distinguish the difference between normal body temperature and the surrounding high temperature. The sensor will begin to work normally once weather conditions return to normal.

<b>Problem</b>	<b>Possible Cause</b>	<b>Corrective Action</b>
Light does not come on at night when Motion detected.	<ol style="list-style-type: none"><li>1. No power is being delivered to the fixture.</li><li>2. Another light source cause the security light to think it is daylight.</li><li>3. Wiring inside electrical box is loose.</li></ol>	<ol style="list-style-type: none"><li>1. Check that circuit breaker and/or wall switch power is on.</li><li>2. Turn off surrounding lights and/or re-aim the sensor head.</li><li>3. After turning power off to the fixture, reconnect any loose wiring.</li></ol>
Security light comes on during the day.	<ol style="list-style-type: none"><li>1. Dusk-to-Dawn sensor is a shaded area and is fooled into thinking it is nighttime.</li><li>2. Dusk-to-Dawn sensor is faulty.</li></ol>	<ol style="list-style-type: none"><li>1. Shine a flashlight onto the light sensor. If the security light turns off then the fixture is mounted in an area that does not allow enough light to enter the sensor. Relocate security light.</li><li>2. If under warranty, contact Customer Service.</li></ol>
Security light cycles ON and OFF continuously.	<ol style="list-style-type: none"><li>1. Dusk-to-Dawn sensor is sensing reflected light from the security light.</li></ol>	<ol style="list-style-type: none"><li>1. Change the position of the light head, aim light away from the reflecting surfaces.</li><li>2. Put a small piece of black electrical tape over the Dusk-to-dawn sensor.</li><li>3. Relocate the security light to a different location where it no longer causes reflected light.</li></ol>
Security light comes on for no apparent reason at night.	<ol style="list-style-type: none"><li>1. Light is sensing motion in the detection zone.</li></ol>	<ol style="list-style-type: none"><li>1. Make sure the sensor is not picking up moving objects such as bushes, trees, traffic, water, etc.</li><li>2. Test the motion sensor by covering up the front curved lens with cardboard to block the view. If the light turns off then something in the detection zone is triggering the sensor. Reposition the motion sensor or change the sensitivity (distance) of the sensor.</li></ol>

## Care & Cleaning



**CAUTION:** Before attempting to clean the fixture, disconnect the power to the fixture by turning the breaker off or removing the fuse from the fuse box.

- Clean the fixture with a soft, dry cloth.
- Do not use cleaners with chemicals, solvents, or harsh abrasives.

## Troubleshooting



**WARNING:** Before doing any work on the fixture, disconnect power to the light fixture.

Minor problems often can be fixed without the help of an electrician.

Problem	Possible Cause	Corrective Action
The fixture will not light.	The power is off.	Ensure the power supply is on.
	The circuit breaker is off.	Ensure the circuit breaker is in the on position.
	There is a bad connection.	Check to ensure proper wire connections are made. Contact a qualified electrician.
	There is a defective switch.	Contact a qualified electrician.
	The photocell is not working.	Replace the photocell according to the instructions in the Maintenance section of this Use and Care Guide.
The fuse blows or the circuit breaker trips when the light is turned on.	The wires are crossed or the power wire is grounding out.	Check the wire connections. Contact a qualified electrician or call Defiant customer service 1-855-384-7754.
The lights flash on and off.	The light reflected from the wall onto the photocell hampers the operation.	Reposition the light heads away from the wall. If the fixture is mounted with the photocell sensor in the down position, the angle between the light head and the wall should be larger than 45° for best performance.



Questions, problems, missing parts?  
Call ETiSSL Customer Service  
8 a.m. - 5 p.m., CST, Monday - Friday

**1-855-ETI-SSL (1-855-384-7754)**

**[www.ETiSSL.com](http://www.ETiSSL.com)**

Retain this manual for future use.