



Whatever you do in bed, Sealy supports it.™

The Reflexion®-4 Adjustable Base

OWNER'S MANUAL



The Reflexion®-4 base can be used in conjunction with both Sealy-Posturepedic and Optimum mattresses.

The Reflexion[®]-4 Adjustable Base



TABLE OF CONTENTS

- 2 Safety Precautions
- 4 Parts List
- 6 Installation Guide
- 8 Using the Remote Control
- 10 Programming the Remote Control
- 11 Lowering the Bed in a Power Outage
- 12 Troubleshooting
- 14 Warranty

Model Number: IC-ABF-A18-WWM-U-W

Safety Precautions

ATTENTION!

IMPORTANT SAFETY INSTRUCTIONS. PLEASE READ THESE INSTRUCTIONS THOROUGHLY BEFORE USING THIS PRODUCT.

ELECTRICAL SAFETY

Always unplug this Adjustable Base from the electrical outlet before any cleaning or maintenance of the bed frame. To safely disconnect, make sure all controls are in the off position, then remove the plug from the outlet.

Keep cord away from heated surfaces. Keep air openings free of lint, hair and the like — never operate when air openings are blocked. Never drop or insert any object into any opening. Use only indoors.

Cease use of this bed frame and contact a qualified service center for repair if:

- It has a damaged cord or plug
- It is not working properly
- It has been dropped or damaged
- It has been dropped into water

GROUNDING SAFETY

To reduce the risk of electric shock, electrical fire, or faulty operation of this product, your Adjustable Base features a polarized plug meant to be used only with a grounded electrical outlet. If this plug does not fit into your outlet, contact a qualified electrician to install a properly grounded outlet. Failure to use a properly grounded outlet for this product will compromise this important grounding safety feature. The use of adapters is not recommended unless the outlet is checked by a qualified electrician to ensure the proper grounding of the adapter.

NOTE:

Unauthorized modifications to this product could void the electrical portion of your warranty.

NOTE:

For optimal safety, your Adjustable Base should be plugged into a surge protector (not supplied with this Adjustable Base).

WARRANTY WARNING!

This Adjustable Base is specifically designed to require no maintenance by you, the user. Any opening or tampering with the control box, motors or hand controls (with the exception of the battery compartment, if equipped) will result in a void of the warranty. Only those authorized may conduct repairs or part replacement on your Adjustable Base.

IN-HOME USE ONLY

This Adjustable Base is designed exclusively for in-home use.

HOSPITAL DISCLAIMER:

It is NOT designed for hospital use and is NOT designed to meet hospital standards. Do not use this bed with TENT TYPE oxygen therapy equipment or use near explosive gases.

IMPORTANT SAFETY FEATURES

Weight Fail Safe Feature — In the case that an overload of weight is placed on the head or foot mechanism, the control unit will automatically stop all functions. The control unit will automatically resume all functions 30 seconds after excess weight is removed.

Locking Caster Feature — This Adjustable Base may be equipped with special locking casters. For your safety, these casters will prevent bed movement when all casters are in the locked position. To lock casters, push down the safety latch on the caster. To resume product mobility, lift the safety latch up.

NOTE:

If your Adjustable Base is positioned on a hard floor surface such as hardwood or tile, it is strongly recommended that rubber caster cups or carpet squares are placed under the casters in addition to locking them in place. Casters will not roll when locked, but may slide on an uncarpeted surface.

CONSUMERS WITH PACEMAKERS

It is possible that the (optional) vibrating feature of this bed may be interpreted falsely by some pacemakers as movement and/or exercise. This is common with any product that produces a vibrating motion, and may or may not affect your pacemaker. Please consult your physician with any concerns.

RADIO FREQUENCY IS 433.92 MHZ

FCC compliance device complies with part 15 of the FCC Rules. Operation is subject to the following two conditions:

- 1 This device may not cause harmful interference
- 2 This device must accept any interference received, including interference that may cause undesired operation

Any change to the antenna or the device could result in the device exceeding the RF exposure requirements and void user's right to operate the device.

The input transformer voltage is AC120V 60HZ; the output voltage is DC24V 3A. In the case of a short-circuit, a fuse on the transformer will blow to protect the electrical equipment of the device (Fuse: 1A~1.5A). Should this occur, you should seek professional assistance to fix the problem, and call Customer Care at: 1-800-499-1965.

PRODUCT RATINGS

Lift Motor Restrictions — The lift motors in this bed are NOT designed to operate continuously for more than 3 minutes over a 30 minute time period, or approximately 10% duty cycle. To ensure reliable functionality and full life of this product, do not attempt to exceed these limits.

NOTE:

Attempting to circumvent or exceed this rating will shorten the life expectancy of the product and may void the warranty.

Weight Restrictions — The recommended weight limits on our Adjustable Bases are:

- Twin/Twin Extra Long/Split Queen/Split CA King: 575 pounds
- Full/Full Extra Long: 600 pounds
- Queen: 650 pounds

The structure of the bed will support the recommended weight when distributed evenly across the bed. **Maximum weight the bed can support per person is 250 pounds. The head and foot sections are not designed to individually support or lift this amount of weight.** For optimal performance, entering and exiting the Adjustable Base with the bed in the flat or level position is recommended.

NOTE:

Exceeding the recommended weight restrictions could damage your Adjustable Base and void your warranty.

SMALL CHILDREN AND PETS WARNING

Immediately dispose of all packing materials as it can pose a smother risk to small children and pets. Injury could occur also if children or pets are permitted to play on or under the bed. Do not allow children to operate this bed without adult supervision.

SAVE THESE INSTRUCTIONS!

Proper operation of your Adjustable Base is necessary to ensure the long life and durability you expect from a high-quality product. The manufacturer has tested and inspected this product prior to shipment.

Parts List

Before discarding any packing materials, check the Adjustable Base carton and verify all items in the parts list are included.



REMOTE CONTROL (1)



MATTRESS RETAINER BRACKET (1) *

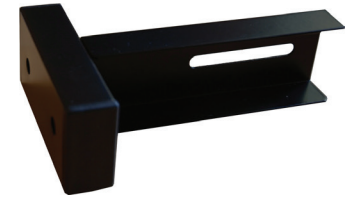

INNER HEADBOARD BRACKET (2) **



BED LEG (4)

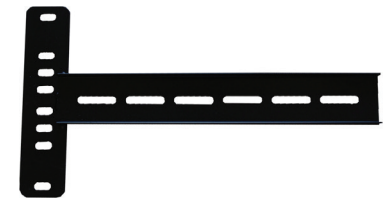

OUTER HEADBOARD BRACKET (2) **

* Indicates part is attached to base for shipping purposes.

** These items are not included. These are optional HBD brackets and parts that can be purchased from your supplier or distributor.

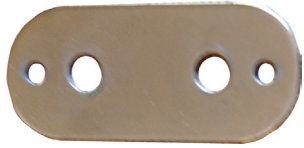

1/4 INCH RETAINER WASHER (2) *



RETAINER BOLT (4) *



ALLEN KEY WRENCH (1)



5/16 INCH WASHER (12) **



HEADBOARD BRACKET BOLT (6) **

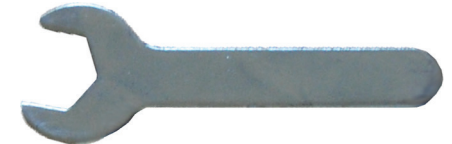

WRENCH (1) **



5/16 INCH NUT (6) **

* Indicates part is attached to base for shipping purposes.

** These items are not included. These are optional HBD brackets and parts that can be purchased from your supplier or distributor.

Installation Guide

STEP 1

For safety reasons, the following should be performed by 2 people. Carefully lift the bed frame unit out of the shipping carton with the top side facing downward.

STEP 2: ASSEMBLE THE BED LEGS

For this step, you will need 4 bed legs (C), which can be found in the accessories box. Turn each bed leg (C) in a clockwise direction into the threaded holes on the frame as shown. Repeat the bed leg assembly for all 4 legs (C) provided.

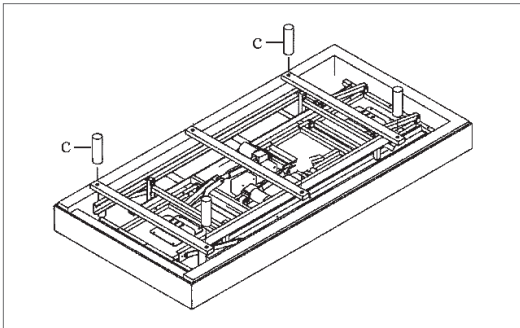

DO NOT OVERTIGHTEN THE BED LEGS.

NOTE:

Bed may be equipped with special locking casters (sold separately). To prevent movement of this product, all casters should be in the locked position. It is recommended that rubber caster cups or carpet squares (not included) are placed under casters in addition to locking them in place. Casters will not roll when locked, but may slide on an uncarpeted surface.

STEP 3

Remove and extend the power cord from the frame.

IMPORTANT!

MAKE SURE POWER CORDS DO NOT OBSTRUCT ANY ADJUSTABLE BASE MECHANISMS.

STEP 4

Take plastic wrapping off the base frame.

STEP 5

Carefully rotate the base frame over so the top side is facing upward.

NOTE:

Be careful not to rest the frame on its side. The weight may damage the legs.

STEP 6

Plug the power cord into a grounded electrical outlet.

NOTE:

For optimal safety, a surge protector should be used (not supplied with this Adjustable Base).

STEP 7

Install batteries in remote control.

Test all functions on the remote control to ensure all features are operational.

If the bed does not work, refer to Troubleshooting on page 12.

STEP 8

Return bed to flat or level position.

STEP 9: ASSEMBLE THE MATTRESS RETAINER BRACKET

Fasten the mattress retainer bracket (B) to the front of the bed frame using the retainer bolts (F) and 1/4 inch retainer washers (H), as shown in the diagram below.

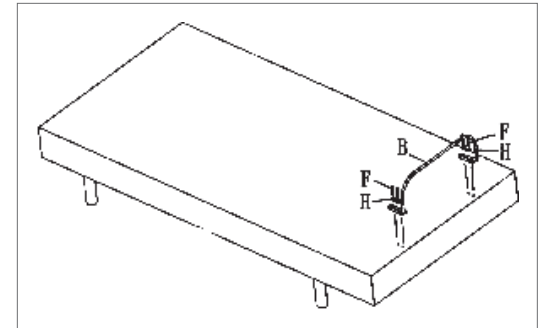

NOTE:

Use ONLY the allen wrench to fasten the retainer bolts. DO NOT use a power screwdriver as it may overtighten the bolts. Mattress retainer hardware must NOT be overtightened.

NOTE:

If a headboard is to be installed, owners who have purchased the optional HBD bracket kit continue on to step 10. If the Adjustable Base is to be set up without a headboard, proceed to step 11.

IMPORTANT!

FAILURE TO FOLLOW THE INSTALLATION STEPS AS THEY APPEAR IN THIS GUIDE COULD RESULT IN DAMAGE TO YOUR ADJUSTABLE BASE.

MAKE SURE TO POSITION THE BOTTOM OF THE HEADBOARD CROSS MEMBER NO MORE THAN 3 INCHES (76.2 MM) BETWEEN THE HEADBOARD AND THE TOP OF THE MATTRESS.

STEP 10: ASSEMBLE THE HEADBOARD BRACKET (SOLD SEPARATELY)

Use the hand control to elevate the head of the bed so the bed base frame is reachable.

A

Slide the inner headboard bracket (D) horizontally with the "C" opening facing down under the crossbar. Position the bracket (D) in the guide peg on the bottom of the crossbar. Insert a headboard bolt (G) fitted with a 5/16 inch washer (I) through the pre-drilled hole in the crossbar and into the pre-drilled slotted hole in the "C" channel inner headboard bracket. Tighten in place with a 5/16 inch washer (I) and 5/16 inch nut (J). Repeat on the other side.

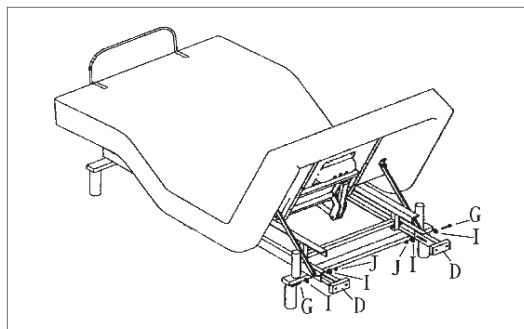

B

Place the open side of the outer headboard bracket (E) onto the exposed square tube of the inner headboard bracket (D) to create a tight fit between (D) and (E). Insert a retainer bolt (G) fitted with a 5/16 inch washer (I) into the outer headboard bracket (E) and through the inner headboard bracket (D). Hand tighten using a 5/16 inch washer (I) and a 5/16 inch nut (J). (Leave loose enough for adjusting.) Repeat on the other side.

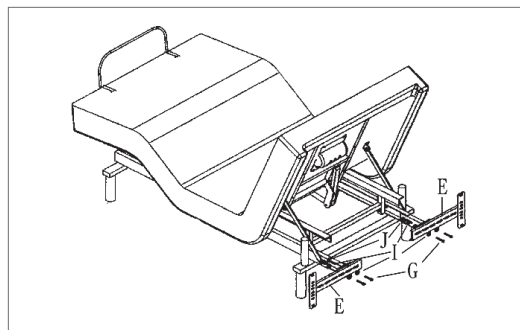

C

When headboard brackets are assembled, make sure there is a space of 1.5 to 2 inches (38.1 to 50.8 mm) between the edge of the bed base and the headboard brackets.

D

Securely fasten the headboard bolts (not included with your Adjustable Base) to the end of the headboard bracket assembly.

E

Measure the distance from the center of one mounting hole in the headboard to the center of the other.

F

Measure the distance from the center of one mounting hole in the headboard bracket assembly to the center of the other.

G

If you need to adjust the headboard brackets, unscrew the bolts holding the outer headboard brackets and move them the necessary distance. Reinstall the bolts and securely tighten.

STEP 11

Place your mattress on the Adjustable Base surface. Installation is now complete.

If the bed comes with a programming option, turn to Using the Remote Control on page 8 to proceed.

Using the Remote Control

A: Under Bed Light
(on back of Remote)

B: Raises the Head
of the Bed

C: Lowers the Head
of the Bed

F: Returns Head and
Foot to Flat Position
(hold 3 seconds)

I: Increases the Intensity
of Vibration (Head)

J: Decreases the Intensity
of Vibration (Head)

M: Stops Massage



LED Signature Light

D: Raises the Foot
of the Bed

E: Lowers the Foot
of the Bed

G: Pre-Programmed
Memory Positions

H: Full Body Massage

K: Increases the Intensity
of Vibration (Foot)

L: Decreases the Intensity
of Vibration (Foot)

N: Turns on Massage Wave
1, 2 or 3

UNDER BED LIGHT (A)

Press the button to turn on or off the under bed light. (button on back of remote control)

HEAD AND FOOT POSITION ADJUSTMENTS (B, C, D, E)

Use to raise or lower the head and foot sections of your Adjustable Base. The premium "Wall-Glide" feature will automatically synchronize with all head and foot adjustments.

BED "FLAT" BUTTON (F)

Press down and hold for 3 seconds to return bed to the flat position.

PRE-PROGRAMMED MEMORY POSITION (G)

These 3 program function keys allow you to select the most popular positions with 1 touch.

FULL BODY MASSAGE (H)

Press to activate both the head and foot massages at the same time.

HEAD AND FOOT MESSAGE ADJUSTMENTS (I, J, K, L)

Use to activate the massage feature on the head and foot of the bed (starting at intensity 4 of 8). Gradually increase or decrease intensity of massage vibration by pressing the appropriate button. The lowest setting on each massage unit will turn off the respective vibration.

IMPORTANT!

FOR YOUR SAFETY, READ THE OWNER'S MANUAL CAREFULLY AND COMPLETELY BEFORE OPERATING THIS PRODUCT. ELECTRIC SHOCK MAY OCCUR IF ELECTRICAL COMPONENTS ARE NOT INSTALLED OR OPERATED ACCORDING TO THESE GUIDELINES.

The massage feature is programmed with an Auto Shut-Off Timer that will automatically turn off the massage after 15 minutes of continuous use.

STOP BUTTON (M)

Hold down for 2 seconds to stop massage.

NOTE:

You must stop massage before alternating between massage functions.

WAVE MESSAGE ADJUSTMENTS (N)

Activates both units to wave mode massage.

NOTE:

You must stop the massage in order to activate another massage setting such as full body or another wave massage.

REMOTE FEATURES

NOTE:

This bed may show minor intermittent performance because of typical RF interference. This is normal in the operation of the bed, not a defect.

- The buttons are backlit, when a button is pressed, to aid in the visibility of the remote in low light environments.

- It is not necessary to face the receiver to operate the remote control. Remote signal is best transmitted within 9 feet (3 meters) of the receiver.

SAFETY

- In the case that an overload of weight is placed on the head or foot mechanism, the control unit will automatically stop all functions. The control unit will automatically resume all functions 30 seconds after excess weight is removed.
- Massage motors will automatically shut off after running continuously for 15 minutes. All massage functions will be operational again after 5 minutes. Automatic Shut Off will occur after 15 minutes of continuous use.
- The input transformer voltage is AC120V 60HZ, the output voltage is DC24V 3A. In the case of a short-circuit, a fuse on the transformer will blow to protect the electrical equipment (Fuse: 1A~1.5A). Should this occur, you **MUST** seek professional assistance to replace the fuse. Call Customer Care at: 1-800-499-1965.

NOTE:

The changes or modifications not expressly approved by the party responsible for compliance could void the user's authority to operate the equipment.

NOTE:

To comply with the FCC RF exposure compliance requirements, no change to the antenna or the device is permitted. Any change to the antenna or the device could result in the device exceeding the RF exposure requirements and void user's authority to operate the device.

This device complies with part 15 of the FCC Rules. Operation is subject to the following two conditions:

- 1 This device may not cause harmful interference
- 2 This device must accept any interference received, including interference that may cause undesired operation

Programming the Remote Control

NOTE:

Programming by the user is only needed on replacement remotes.

Follow steps 1 through 6 below to use the remote control with 1 power base.
To use the remote control with 2 power bases, repeat the steps for the second power base using the same remote.

STEP 1

Insert batteries into the remote control (2 x AA batteries).

STEP 2

Make sure your Adjustable Base is plugged into a working grounded outlet or surge protector.

STEP 3



Hold down the "Learn" button for 3 seconds to initiate the RF learning mode.

STEP 4



The LED signature light will illuminate. This means the RF frequency code setting function has been activated.

STEP 5



Press any button on the remote control.

STEP 6



When the receiver light flashes, the RF frequency code learning process is complete.

Lowering the Bed in a Power Outage

Your Adjustable Base is equipped with an emergency lowering feature. Follow the steps below in the event that your base is in the raised position during a power outage.

NOTE:

The 2 alkaline 9 volt batteries are only rated for single use. After the emergency lowering, replace with new batteries.

STEP 1



Locate and remove the 9 volt battery cover.

STEP 3



Replace the battery cover.

STEP 2



Install 2 alkaline 9 volt batteries (not included).

STEP 4



Press either the "Flat" button (F) or the individual lowering buttons (C, E) to lower your bed to the level position.

Troubleshooting

In the event the Adjustable Base fails to operate, investigate the problems and possible solutions provided below.

REMOTE CONTROL LED ILLUMINATES AND APPEARS NORMAL, BUT WILL NOT OPERATE BED

- 1 Is the power cord plugged into a working and grounded electrical outlet?

NOTE:

A grounded, electrical surge protection device is recommended (not supplied).

- 2 Test outlet by plugging in an appliance you know works properly.
- 3 Check low amp fuse on the control box under bed. Replace fuse if blown.

NONE OF THE FUNCTIONS ON THE ADJUSTABLE BASE WILL OPERATE

- 1 Re-program the remote control (as indicated in the Manual provided with this product, for programming procedures).
- 2 Unplug the power cord. After 45 seconds, plug in to electrical outlet. This should reset the electronic components.
- 3 The home electrical circuit breaker may have been tripped. Reset circuit breaker if needed.
- 4 Check surge protection device or electrical outlet to insure working order. Test outlet by plugging in a known working appliance.
- 5 Check low amp fuse on control box under bed. Replace fuse if blown.

REMOTE CONTROL FUNCTION KEYS WILL NOT ILLUMINATE

- 1 Replace batteries in the remote control.
- 2 Check that batteries are installed properly.

HEAD OR FOOT SECTION FUNCTION KEY WILL ELEVATE BED, BUT WILL NOT RETURN TO THE HORIZONTAL (FLAT) POSITION

- 1 Your bed may be obstructed preventing smooth operation. Remove obstructions from around and under the bed.
- 2 Check that head section has clearance from headboard or wall.
- 3 Headboard may be too close the edge of the mattresses. Verify a 1.5 to 2 inch (38.1 to 50.8 mm) distance between headboard brackets and mattress. Adjust if required.

ACTIVATING HEAD OR FOOT LIFT FUNCTION CAUSES "PULSING" OR "STUTTERING" WHEN OPERATING FEATURE

- 1 Check batteries and installation in remote.
- 2 Assure that the function key is pressed directly and firmly.
- 3 Radio frequency interference from other remotes or electronic devices may be affecting normal operation.

MESSAGE MOTORS SEEM EXCESSIVELY LOUD DURING OPERATION

- 1 Hard surface flooring may cause added vibration. To correct, place carpet pieces or rubber furniture cups under each leg or caster of the bed.
- 2 Elevate the head or foot section a short distance (with the remote control) to realign the lift/lower mechanisms with the bed support platform.
- 3 Check that the bed is not in direct contact with a wall, nightstand, or other object that may cause vibration or noise.
- 4 If Adjustable Base is installed on top of a bed frame, check that the massage motors are not causing bed frame (or bed frame components) to vibrate or rattle.
- 5 Check that the headboard attachment hardware is tightened firmly (if used).

IF YOU EXPERIENCE ANY TROUBLE
WITH YOUR ADJUSTABLE BASE WITHIN
THE WARRANTY PERIOD, PLEASE
CONSULT THE TROUBLESHOOTING
GUIDE PROVIDED WITH YOUR
FRAME AND ONLINE (IF APPLICABLE).
IF PROBLEMS PERSIST, PLEASE CALL.

CUSTOMER SERVICE

TOLL FREE NUMBER:

1-800-499-1965

Please have your receipt ready
and available.

THANK YOU AND ENJOY YOUR
ADJUSTABLE BASE!



Warranty

**ADJUSTABLE BASE:
20-YEAR LIMITED WARRANTY**
SEALY, INC. ("SEALY®") GUARANTEES
THAT WE WILL, AT SEALY'S OPTION,
REPLACE OR REPAIR PURCHASER'S
REFLEXION® SYSTEM IF IT IS DEFECTIVE
DUE TO FAULTY WORKMANSHIP
OR MATERIALS, SUBJECT TO
THE LIMITATIONS DESCRIBED IN
THIS WARRANTY.

**YEAR 1: FULL COVERAGE
OF PARTS AND LABOR**

Your Reflexion® adjustable base system is warranted against defects in the workmanship or materials for a period of one (1) year from the warranty commencement date. Electronics, electrical components, drive motors and massage motors are included. Upon notice during the first year from the warranty commencement date, Sealy will send replacement parts (at no cost to the purchaser) for any defective part to the purchaser, and Sealy will pay all authorized labor and transportation costs associated with the repair or replacement of any parts Sealy determines to be defective. This one (1) year warranty shall not apply if purchaser does not return any and all defective parts to Sealy within 15 days of purchaser's receipt of replacement part.

**YEARS 2 AND 3: FULL COVERAGE
OF PARTS ONLY**

Upon notice during the years two and three (2–3) from the warranty commencement date, Sealy will offer replacement parts for any defective part to the purchaser. Electronics, electrical components, drive motors and massage motors are included. This two (2) year warranty shall not apply if purchaser does not return any and all defective parts to Sealy within 15 days of purchaser's receipt of replacement part. Purchaser shall bear all service, transportation, labor, and shipping costs related to the delivery and/or replacement of the defective part.

**YEARS 4 THROUGH 20: PRORATED
COVERAGE OF PARTS ONLY**

Upon notice during the fourth through the twentieth (4–20) years from the warranty commencement date, Sealy will offer replacement parts (upon terms and conditions set forth in this paragraph) for any mechanical bed part found to be defective. Electronics, electrical components, drive motors and massage motors are excluded. Purchaser shall pay 1/17th of the then current replacement cost of the defective part multiplied by the number of years after three (3) years from the warranty commencement date, and Sealy shall bear the remainder of the cost of the replacement part. This seventeen (17) year warranty shall not apply if purchaser does not return any and all defective parts to Sealy within 15 days of purchaser's receipt of replacement part. Purchaser shall bear all service, transportation, labor, and shipping costs related to the delivery and/ or replacement of the defective part. After the 20th year,

purchaser shall bear the entire cost of repair and replacement of all parts and materials, including labor and transportation.

**ADDITIONAL TERMS
AND CONDITIONS**

This warranty does not apply;

- a to any damage caused by the purchaser;
- b if there has been any unauthorized repair or replacement of the unit's parts;
- c if the unit has been mishandled (whether in transit or by other means), subjected to physical or electrical abuse or misuse, or otherwise operated in any way inconsistent with the operation and maintenance procedures outlined in the Complete Reference Guide, this warranty, and any other applicable document published or approved by Sealy;
- d to damage to mattresses, fabric, cables, electrical cords or items supplied by Resellers;
- e if there has been any unnecessary service calls, including costs for in-home service calls solely for the purpose of educating the consumer about the unit for finding an unsatisfactory power connection; and
- g if the recommended weight restrictions are not followed (Twin Long, Split/Dual CA King: 300 lbs.; Queen: 425 lbs.), the warranty will be void.

Repairs to or replacement of the Reflexion® system or its components under the terms of this limited warranty will apply to the original warranty period and will not serve to extend such period.

The decision to repair or to replace defective parts under this warranty shall be made, or case to be made, by Sealy at its option and in its sole discretion.

REPAIR OR REPLACEMENT SHALL BE THE SOLE REMEDY OF THE PURCHASER. THERE SHALL BE NO LIABILITY ON THE PART OF SEALY FOR ANY SPECIAL, INDIRECT, INCIDENTAL, OR CONSEQUENTIAL DAMAGES OR FOR ANY OTHER DAMAGE, CLAIM, OR LOSS NOT EXPRESSLY COVERED BY THE TERMS OF THIS WARRANTY. THIS LIMITED WARRANTY DOES NOT INCLUDE REIMBURSEMENT FOR INCONVENIENCE, REMOVAL, INSTALLATION, SETUP TIME, LOSS OF USE, SHIPPING, OR ANY OTHER COSTS OR EXPENSES. SEALY MAKES NO OTHER WARRANTY WHATSOEVER, EXPRESS OR IMPLIED, AND ALL IMPLIED WARRANTIES OF MERCHANTABILITY AND FITNESS FOR A PARTICULAR PURPOSE ARE DISCLAIMED BY SEALY AND EXCLUDED FROM THIS AGREEMENT.

Some states do not allow the exclusion or limitation of incidental or consequential damages, so the above limitation or exclusion may not apply to every purchaser. This warranty gives the purchaser specific legal rights, and the purchaser may also have other rights, which may vary from state to state. This warranty is valid in all 50 states, Puerto Rico, and Canada. This warranty is valid only for the original purchaser of the product. An original purchaser is one who purchases the product directly from Sealy, Inc. or an authorized Reseller of Sealy, Inc. If you are not the original purchaser of this product, you take it "as is" and "with all faults."

If you did not purchase this Reflexion® system directly from Sealy, Inc., we will require proof of purchase from you demonstrating that you are the original purchaser and eligible to make a valid claim under this warranty. This warranty begins on the "warranty commencement date" which is the date of purchase for new unused units, and the date of manufacture for units that have been used as floor or display models. Thus, on a floor model unit, the warranty is a portion of the limited 20-year warranty. If original proof of purchase is not provided by purchaser, Sealy reserves the right to determine if the unit is not covered by this warranty or to use the manufacturing date as the warranty commencement date. This limited warranty gives you specific legal rights. You may also have other rights that vary from state to state.

BINDING ARBITRATION AND CLASS ACTION WAIVER FOR U.S. RESIDENTS

a This section applies to any dispute except it does not include a Dispute relating to the enforcement or validity of your, Sealy's, or any of our licensors' intellectual property rights. "Dispute" means any dispute, action, or other controversy between you and Sealy concerning your Sealy mattress or this warranty, whether in contract, warranty, tort, statute, regulation, ordinance, or any other legal or equitable basis. "Dispute" will be given the broadest possible meaning allowable under law.

- b In the event of a dispute, you or Sealy must give the other a Notice of Dispute, which is a written statement that sets forth the name, address and contact information of the party giving it, the facts giving rise to the dispute, and the relief requested. You must send any Notice of Dispute by U.S. Mail to Sealy, Inc., ATTN: Office of General Counsel, 1000 Tempur Way, Lexington, KY 40511. Sealy will send any Notice of Dispute to You by U.S. Mail to Your address if we have it or to your email address if we have it. You and Sealy will attempt to resolve any dispute through informal negotiation within 60 days from the date the Notice of Dispute is sent. After 60 days, you or Sealy may commence arbitration.
- c You may also litigate any dispute in small claims court in your county of residence or Fayette County, Kentucky if the dispute meets all requirements to be heard in the small claims court. You may litigate in small claims court whether or not you negotiated informally first.
- d If you and Sealy do not resolve any dispute by informal negotiation or in small claims court, any other effort to resolve the dispute will be conducted exclusively by binding arbitration. You are giving up the right to litigate (or participate in as a party or class member) all disputes in court before a judge or jury. Instead, all disputes will be resolved before a neutral arbitrator, whose decision will be final except for a limited right of appeal under the Federal Arbitration Act. Any court with jurisdiction over the parties may enforce the arbitrator's award.

Warranty (continued)

- e Any proceedings to resolve or litigate any dispute in any forum will be conducted solely on an individual basis. Neither You nor Sealy will seek to have any dispute heard as a class action, private attorney general action, or in any other proceeding in which either party acts or proposes to act in a representative capacity. No arbitration or proceeding will be combined with another without the prior written consent of all parties to all affected arbitrations or proceedings.
- f Any arbitration will be conducted by the American Arbitration Association (the "AAA") under its Commercial Arbitration Rules applying U.S. Federal Rules of Procedure and U.S. Federal Rules of Evidence. The AAA Supplementary Procedures for Consumer-Related Disputes will also apply. For more information, see www.adr.org or call 1-800-778-7879. You agree to commence arbitration only in your county of residence or in Fayette County, Kentucky. Sealy agrees to commence arbitration only in your county of residence. You may request a telephonic or in-person hearing by following the AAA rules. In a dispute involving \$10,000 or less, any hearing will be telephonic unless the arbitrator finds good cause to hold an in-person hearing instead. The arbitrator may award the same damages to you individually as a court could. The arbitrator may award declaratory or injunctive relief only to you individually, and only to the extent required to satisfy your individual claim.
- g Sealy will promptly reimburse your filing fees and pay the AAA's and arbitrator's fees and expenses as provided below. If you reject Sealy's last written settlement offer made before the arbitrator was appointed ("Sealy's last written offer"), your dispute goes all the way to an arbitrator's decision (called an "award"), and the arbitrator awards you more than Sealy's last written offer, Sealy will give you three incentives: (i) pay the greater of the award or \$5,000; (ii) pay twice your reasonable attorney's fees, if any; and (iii) reimburse any expenses (including expert witness fees and costs) that your attorney reasonably accrues for investigating, preparing, and pursuing your claim in arbitration. The arbitrator will determine the amount of fees, costs, and expenses unless you and Sealy agree on them. For purposes of this limited warranty, an email shall be considered a written communication.
- h In any arbitration you commence, Sealy will seek its AAA or arbitrator's fees and expenses, or your filing fees if reimbursed, only if the arbitrator finds the arbitration frivolous or brought for an improper purpose. In any arbitration Sealy commences, Sealy will pay all filing, AAA, and arbitrator's fees and expenses. Sealy may also seek its attorney's fees or expenses from you in any arbitration. Fees and expenses are not counted in determining how much a dispute involves.
- i This warranty governs to the extent it conflicts with AAA's Commercial Arbitration Rules and Supplementary Procedures for Consumer-Related Disputes.
- j To the extent permitted by law, any claim or dispute under this Limited Warranty must be filed within one year in small claims court, an arbitration proceeding, or in court, if so permitted herein. The one-year period begins when the claim or Notice of Dispute first could be filed. If a claim or dispute is not filed within one year, it is permanently barred.
- k If the class action waiver is found to be illegal or unenforceable as to all or some parts of a dispute, then it will not apply to those parts. Instead, those parts will be severed and proceed in a court of law, with the remaining parts proceeding in arbitration. If any other provision of this section is found to be illegal or unenforceable, that provision will be severed with the remainder of this section remaining in full force and effect.

All parts of this Limited Warranty apply to the maximum extent permitted by law or unless prohibited by law. This Limited Warranty gives the purchaser specific legal rights, and the purchaser may also have other rights, which may vary from state to state.

If you experience any trouble with your Reflexion® system during the warranty period, please consult the troubleshooting section of your Reference Guide. If problems persist after following these instructions, please call: 1-800-499-1965.

IF YOU EXPERIENCE ANY TROUBLE WITH YOUR ADJUSTABLE BASE
WITHIN THE WARRANTY PERIOD, PLEASE CONSULT THE TROUBLESHOOTING
GUIDE PROVIDED WITH YOUR FRAME AND ONLINE (IF APPLICABLE).
IF PROBLEMS PERSIST, PLEASE CALL.

CUSTOMER SERVICE TOLL FREE NUMBER:
1-800-499-1965

Please have your receipt ready and available.

THANK YOU AND ENJOY YOUR ADJUSTABLE BASE!

Model Number: 609663

Serial Number: _____

(Place your serial number here for ready reference.)

