



X-3400A, X-3500, X-3700

OWNER'S MANUAL



XPOWER MANUFACTURE, INC.
220 Clary Avenue
San Gabriel, CA 91776, USA

[Tel: 626-285-3301](tel:626-285-3301), [Fax: 626-285-3300](tel:626-285-3300)

PLEASE READ AND SAVE THESE INSTRUCTIONS



Index

Introduction.....	2
Operation Instructions.....	3
Safety Instructions.....	4
Maintenance Instructions/Troubleshooting.....	5-6
Specifications.....	7
Parts List.....	8-9
Accessories	10-12
Warranty/Service.....	13
Warranty Registration Form	14

Introduction

Introducing XPOWER's unique and highly innovative air scrubbers: X-3400A, X-3500 & X-3700. Using the advanced technology 4-stage filtration system that includes a washable outer round nylon mesh, an inner nylon mesh, pleated media filter, HEPA and activated carbon filters – you can be sure the XPOWER Air Scrubbers can contain ground-water contaminants that lead to environmental and human toxicity. The 4-stage air filtration system captures a wide range of compounds and prevents organism migration from location to location.

Features:

- Advanced filtration technology: X-3400A with 3-stage filter system; X-3500 & X-3700 with 4-stage filter system
- HEPA filter captures 99.9% of smaller particles down to 0.3-microns
- Low amp usage with high airflow capacity from 600 to 750 CFM
- Easy cord wrap design
- Filter change light illuminates when insufficient air passes through the HEPA filter
- Stackable, compact and lightweight design
- X-3400A with GFCI daisy chain capability - connects up to 3 units using one power circuit
- 2 airflow positions – upright (vertical) or horizontal
- Durable and rugged ABS housing with 1 year warranty

Operation

In order to remove airborne particles from the surrounding environment, XPOWER Air Scrubbers are designed to draw air through a series of filters and deliver the purest air. Each filter stage operates with progressively higher efficiency. The unit removes airborne particles like hair, skin flakes, visible dust, mold spores, pollen, pet dander and miscellaneous debris.

1. XPOWER Air Scrubbers are shipped ready-to-use. Prior to plugging the unit into the power source, inspect completely for any shipping damage.
2. Carefully place the Air Scrubbers upright on a stable, flat dry surface.
3. Plug the electrical cord into the power outlet.
4. The unit is capable to be used at 2 different angle positions: vertical and horizontal.
5. Turn the switch control knob to desired speed and make sure the unit operates normally.
6. To reduce the risk of injury, close supervision is necessary when the machine is used near children. Do not allow children to play with or around the Air Scrubber at any time.



Air Scrubbers Storage

Air Scrubbers can be stacked (up to 5) on their sides for storage. Stacking feature is not secure for transportation

Safety Instructions

1. To prevent electric shock, do not operate the unit in standing water. Never plug in or unplug the unit with wet hands or while standing in water.
2. To avoid risk of injury, do not direct air flow at face or body.
3. Use only with GFCI protected receptacles. Please contact a qualified electrician for verification and / or installation of a GFCI receptacle if necessary.
4. Do not operate any unit with a damaged cord or plug. Discard Air Scrubbers or return to an authorized service facility for examination and/or repair.
5. Air Scrubber is automatically operated device. To reduce the risk of injury, disconnect from power supply before servicing.
6. Do not run cord under carpet. Do not cover cord with throw rugs, runners, or similar coverings. Do not route cord under furniture or appliances. Arrange cord away from traffic area and where it will not be tripped over.
7. Do not allow children to play with or around the Air Scrubbers at any time.
8. Do not move or carry the Air Scrubbers while unit is operating.
9. Keep air intakes and exhausts clean at all times. Avoid clogging or blocking to prevent the machine from overheating. Blocking the air intake could result in a fire or electrical hazards.
10. Always place the Air Scrubbers on a smooth and level surface for safe operation.
11. Unplug the unit before performing any maintenance, cleaning, or servicing.
12. Any misuse or abuse of this product will void the warranty.

Maintenance Instructions

1. To keep the Air Scrubber clean, use a damp cloth to wipe the surface of the housing.
2. Never clean the Air Scrubber with water.
3. When not in use, unplug and store the Air Scrubber in a dry indoor place out of reach of children.
4. Always disconnect the Air Scrubber from its power source before performing any maintenance or cleaning.

Filter Replacement

Always wear a respirator and personal protective gadgets when removing or replacing filters. Lay the Air Scrubber flat, unlock top latch of the housing, open the inlet panel and remove filters.

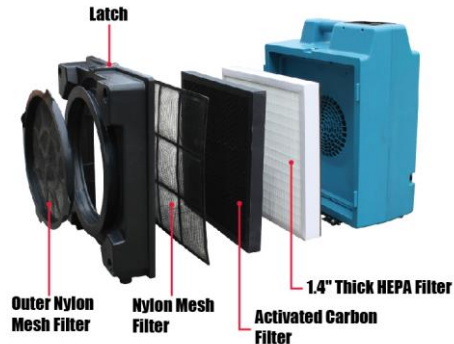

SYMPTOM	POSSIBLE CAUSE	ACTION
Motor not running	Switched off	Make sure unit is plugged in and switch is turned to ON mode
	Power failure	Check outlet/change to another outlet
	Wiring failure	Contact XPOWER for service/repair.
Scraping noise from fan	Obstruction at the intake or exhaust of fan	Remove obstruction
	Fan broken	Contact XPOWER for service/repair
Weak air flow	Obstructed vents and/or filters	Clean out vents/inlets/filters
Change light illuminated	Insufficient airflow caused by clogged filters	Replace the filters

Specifications

Model	X-3400A	X-3500	X-3700
Volt / Frequency	115V / 60Hz	115V / 60Hz	115V / 60Hz
Power	220W	220W	220W
Amp	2.8 Amp	2.3 Amp	2.3 Amp
Rated Airflow (On High)	600 CFM	550 CFM	550 CFM
Speed	Variable Speed	Variable Speed	Variable Speed
Unit Weight	28.8 LBS	33.5 LBS	31.8 LBS
Unit / Box Dimensions (L x W x H)	19.6" x 12.3" x 21.6" / 21.3" x 14" x 23"	19.6" x 12.3" x 21.6" / 20" x 12.7" x 22"	18.5" x 12.3" x 21.6" / 21.3" x 14" x 23"
Power Cord (Length/Size)	13'/14AWG	13'/18AWG	13'/18AWG
Housing	Injection-molded ABS	Injection-molded ABS	Injection-molded ABS
Filtration System	3-Stage	4-Stage	4-Stage
HEPA Efficiency	99.97% against 0.3-micron airborne particles		
Airflow Position	2 positions: Horizontal and Vertical		
GFCI Daisy chain	Yes	No	No

X-3400A Parts list

Item No.	Parts Name	Item No.	Parts Name
1	Removable Air Inlet Foam Cap	2	Air Inlet
3	Inlet Panel	4	Latch
5	16"x16" Nylon Mesh Filter	6	Activated Carbon Filter
7	2" Thick HEPA Filter	8	GFCI Receptacle
9	Front Housing	10	Pressure Switch
11	Fan	12	Motor
13	HEPA Filter Change Light	14	Speed Control Knob
15	Control Panel	16	Potentiometer
17	Air Outlet Grill	18	Rear Housing

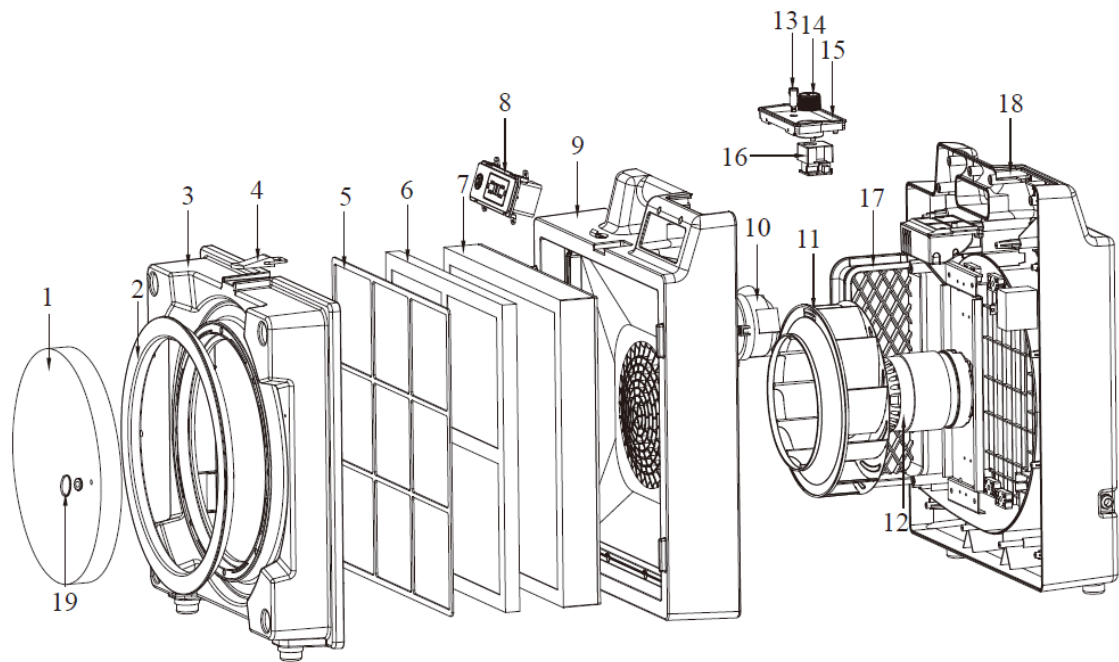

Accessories

X-3400A GFCI Daisy Chain

XPOWER X-3400A Air Scrubber is GFCI daisy chainable with a low 2.8 amp draw.

The 12-amp on-board circuit breaker will allow three (3) additional X-3400A units to run on one circuit at the same time.

X-3400A Air Scrubber has an on-board Circuit Breaker. If the Auxiliary Outlet overloads, the Circuit Breaker will trip. If the Breaker does trip, unplug the units and press the Circuit Breaker Reset button. Plug the units back into the power source and turn on the switch.



Filter Change Light

The Red Filter Change Light will illuminate when accumulated debris is over-saturated, filter needs to be changed



Filter Description



X-3400A

3-STAGE FILTER SYSTEM

1st stage - Nylon Mesh Filter

2nd stage - Pleated Media Filter

3rd stage - 2" Thick HEPA Filter



X-3500

4-STAGE FILTER SYSTEM

1st stage - Outer Nylon Mesh Filter

2nd stage - Nylon Mesh Filter

3rd stage - Activated Carbon Filter

4th stage - 1.4" Thick HEPA Filter



X-3700

4-STAGE FILTER SYSTEM

1st stage - Nylon Mesh Filter

2nd stage - Pleated Media Filter

3rd stage - Activated Carbon Filter

4th stage - 2" Thick HEPA Filter



12" Ø I.D.
Outer Nylon
Mesh Filter



16"x16"
Nylon
Mesh Filter



16"x16"
Pleated
Media Filter



16"x16"
Activated
Carbon Filter



16"x16"
HEPA Filter
1.4" Thick / 2" Thick

XPOWER Limited Warranty (USA)

XPOWER's Limited Warranty covers the unit (excludes POWER CORD) from defects in material and craftsmanship. The Warranty covers normal use for a term of one year from the original date of purchase including parts, labor and one way shipping. Non-contiguous states must pay for roundtrip freight. A purchase receipt must be provided.

Important!

This warranty does not cover or apply to defects due directly or indirectly to misuse, abuse, disassembly, alteration, corrosive chemicals, improper voltage, fire, flood, negligence, accident, improperly or incorrectly performed maintenance or repair, or failure to perform necessary maintenance or repair, or if the use of this product is not in compliance with the instructions and specifications for its use.

Service

For Warranty service and parts replacement (US customers only), you must:

- A. Call 1-855-855-8868 for a RMA (Return-Merchandise-Authorization) number.
- B. Have original proof of purchase.
- C. Use the original undamaged packaging or an industrial certified packaging method.

End user will be responsible to ship the unit (with RMA Number showing on the shipping label) to the XPOWER Service Department. XPOWER to inspect, assess and advise the repairs needed and the applicable cost, if any.

For customers outside the US, please contact XPOWER Distributor in your country or region for Warranty service and parts replacement.

WARRANTY REGISTRATION (for US customers only)

For your product warranty, please complete and mail / fax this form to XPOWER MANUFACTURE, INC.

Address: 220 Clary Ave., San Gabriel, CA 91776. Tel: 626-285-3301; Fax: 626-285-3302

Company Name / Contact Person / Title _____

Address _____ City _____

State / Province _____ Zip _____ Country _____

Phone _____ Fax _____ E-mail _____

Model # _____ Serial # _____

Date of Purchase ____/____/____ Purchased From _____

-

From: _____

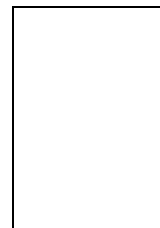

TO:
XPOWER MANUFACTURE, INC.
220 Clary Avenue
San Gabriel, CA 91776, USA
Tel: 626-285-3301; Fax: 626-285-3302

