

HOME
DECORATORS
COLLECTION

Item # 0000000000
Model # 11211

USE AND CARE GUIDE

1 LIGHT CRYSTAL MINI PENDANT (POLISHED NICKEL FINISH)

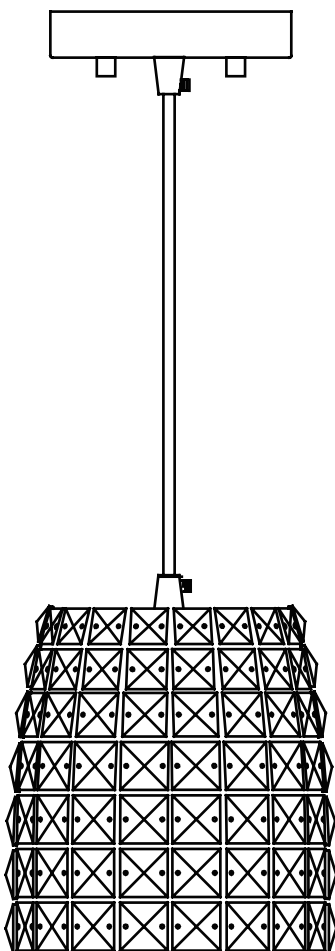

Questions, problems, missing parts? Before returning to the store,
call Home Decorators Collection Customer Service
8 a.m. - 7 p.m., EST, Monday - Friday, 9 a.m. - 6 p.m., EST, Saturday

1-800-986-3460

HOMEDEPOT.COM/HOMEDECORATORS

THANK YOU

We appreciate the trust and confidence you have placed in Home Decorators Collection through the purchase of this Pendant. We strive to continually create quality products designed to enhance your home. Visit us online to see our full line of products available for your home improvement needs. Thank you for choosing Home Decorators Collection!

Table of Contents

Table of Contents.....	2	Hardware Included.....	3
Safety Information.....	2	Package Contents.....	4
Warranty.....	2	Installation.....	5
Pre-Installation.....	3	Care & Cleaning.....	7
Planning Installation.....	3	Troubleshooting.....	7
Tools Required.....	3		

Safety Information

- Consult a qualified electrician for the installation of this fixture.
- If you have any non-electrical questions about this fixture, please contact our Customer Service Team at 1-800-986-3460 or visit www.homedepot.com/HomeDecorators. Please reference your SKU 0000000000 or (UPC 0000000000).
- Keep your receipt and these instructions for proof of purchase.



WARNING: Before starting installation of this fixture or removal of a previous fixture, disconnect the power by turning off the circuit breaker or by removing the fuse at the fuse box.



CAUTION: Inspect the wire insulation for any cuts, abrasions, or exposed copper that have occurred during shipping. If there is a defect in the wire, do not continue the assembly process. Please call our Customer Service Team at 1-800-986-3460.

Warranty

LIMITED WARRANTY

WHAT IS COVERED

The manufacturer warrants this lighting fixture to be free from defects in materials and workmanship for a period of three (3) years from date of purchase. This warranty applies only to the original consumer purchaser and only to products used in normal use and service. If this product is found to be defective, the manufacturer's only obligation, and your exclusive remedy, is the repair or replacement of the product at the manufacturer's discretion, provided that the product has not been damaged through misuse, abuse, accident, modifications, alterations, neglect, or mishandling.

WHAT IS NOT COVERED

This warranty shall not apply to any product that is found to have been improperly installed, set-up, or used in any way not in accordance with the instructions supplied with the product. This warranty shall not apply to a failure of the product as a result of an accident, misuse, abuse, negligence, alteration, or faulty installation, or any other failure not relating to faulty material or workmanship. This warranty shall not apply to the finish on any portion of the product, such as surface and/or weathering, as this is considered normal wear and tear. The manufacturer does not warrant and specially disclaims any warranty, whether express or implied, of fitness for a particular purpose, other than the warranty contained herein. The manufacturer specifically disclaims any liability and shall not be liable for any consequential or incidental loss or damage, including but not limited to any labor/expense costs involved in the replacement or repair of said product.

Contact Customer Care at 1-800-986-3460 or visit www.HomeDepot.com/HomeDecorators.

Pre-Installation

PLANNING INSTALLATION

Read all of these instructions before assembling and installing. To avoid damaging this product, assemble it on a soft, non-abrasive surface such as carpet or cardboard. Inspect each part for defects that may have occurred during shipping. Keep your receipt and these instructions for proof of purchase.

TOOLS REQUIRED



Safety goggles



Pliers



Phillips screwdriver



Flathead screwdriver



Wire strippers



Wire cutters



Ladder



Electrical tape

HARDWARE INCLUDED



NOTE: Hardware not shown to actual size.



AA

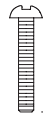

BB



CC



DD



EE



FF



GG

Part	Description	Quantity
AA	Wire nut	3
BB	Outlet box screw	2
CC	Ground screw	1
DD	Circular strap	1
EE	Mounting screw	2
FF	Hex nut	2
GG	Lock knob	2

Pre-Installation (continued)

PACKAGE CONTENTS

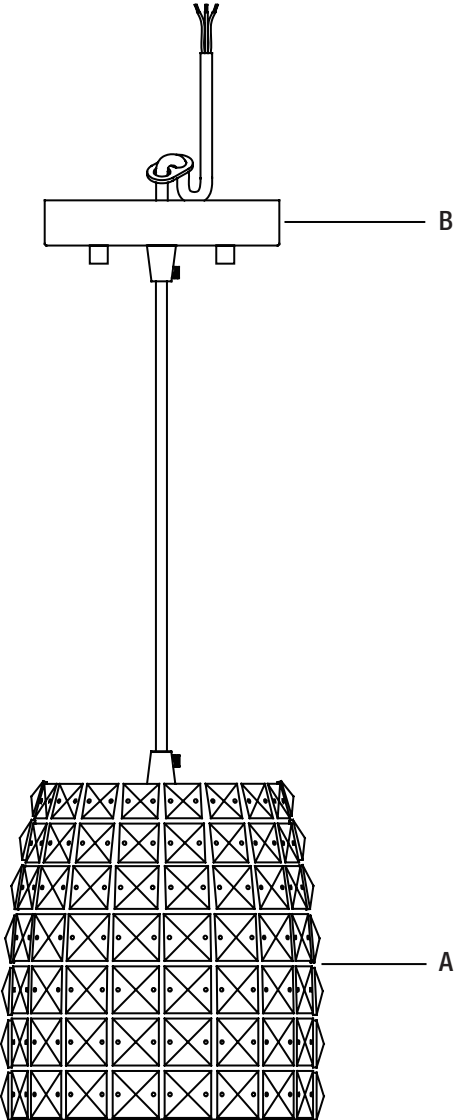

Part	Description	Quantity
A	Fixture body	1
B	Canopy	1

Installation

1 Installing the circular strap

- Unscrew the lock knobs (GG) from the mounting screws (EE).
- Secure the circular strap (DD) to the outlet box (not included) with the outlet box screws (BB), make sure the "GND" on the circular strap (DD) facing out. Tighten until snug.

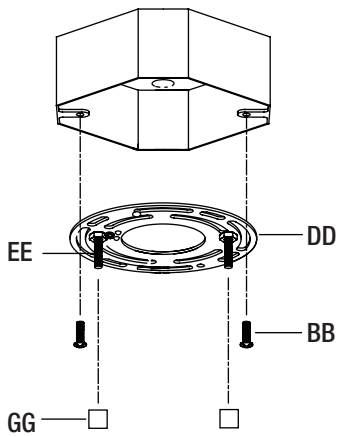

2 Adjusting the length of cable

- Carefully unpack the fixture, and lay out all the parts on a clean or soft surface.
- Unscrew the set screw on the side of the cable clamp with a flathead screwdriver (not provided) and adjust the buckle, pull the cable up or down to your desired length if necessary but never less than 4 in. from the mounting area or ceiling.
- Cut off the excess cable but allow for 6 in. to remain from the canopy (B) for installation.
- Separate a portion of the pendant cable from the interior insulated wire and expose about 1/2 in. of the insulated wire. (See Fig. 1).

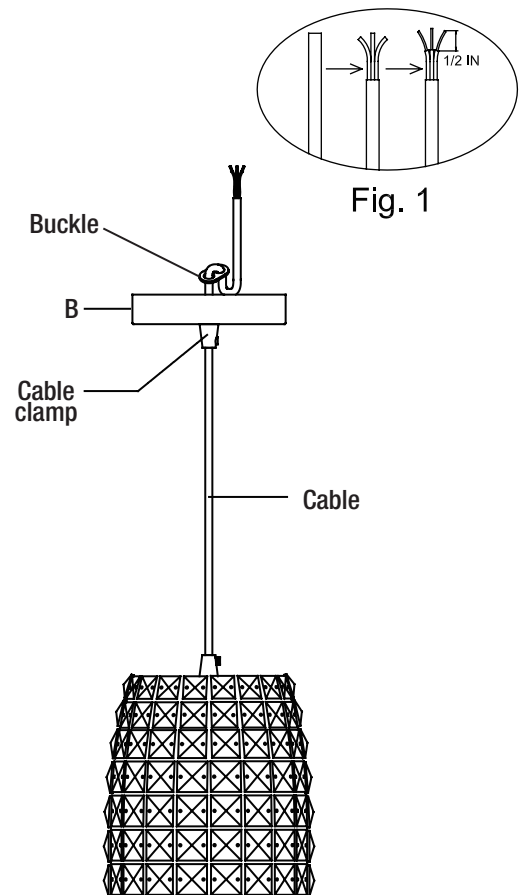

Installation (continued)

3 Making the electrical connections

CAUTION: Ensure that the outlet box in your home is properly grounded.

NOTE: Always use wire nuts (AA) or marrettes (included) to connect wires, and push all excess wires and connections back into the outlet box.

- Attach the ground (GREEN or BARE) fixture wire to either the ground screw (CC) on the circular strap (DD) or the ground (usually GREEN or BARE) wire from the outlet box. If attaching to ground wire from the outlet box, fasten the wires together with a wire connector (AA), and tightly wrap with electrical tape (not included).
- Connect the neutral (WHITE or IDENTIFIED side) fixture wire to the neutral (usually WHITE) wire from the outlet box. Fasten wires together with a wire connector (AA), and tightly wrap the wire connector (AA) with electrical tape.
- Connect the hot (BLACK or PLAIN side) fixture wire to the hot (usually BLACK) wire from the outlet box. Fasten wires together with a wire connector (AA), and tightly wrap the wire connector (AA) with electrical tape.

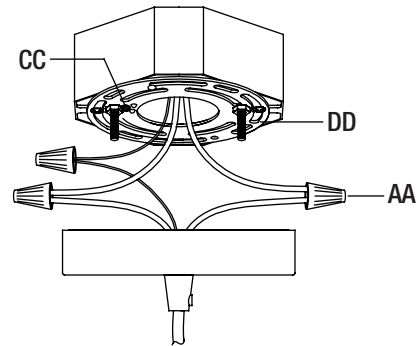
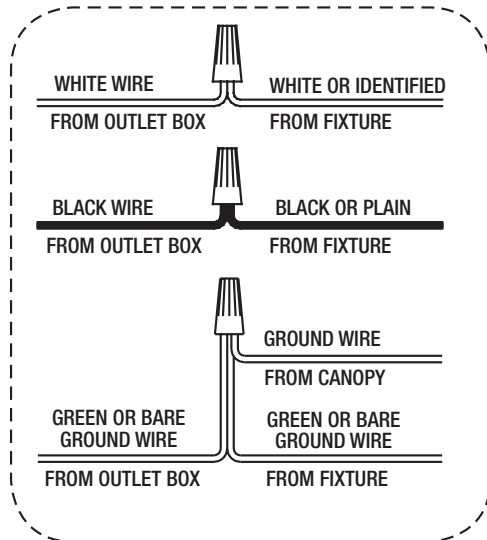

4 Installing the canopy and bulb

- Adjust the mounting screws (EE) in place and fasten the hex nut (FF) if necessary. Lift the canopy (B) upwards to the mounting screws (EE) and secure it with the lock knobs (GG). Hand tighten until snug.
- Install (1) Medium base bulb up to 60 watts or CFL or LED equivalent (sold separately) into the socket.

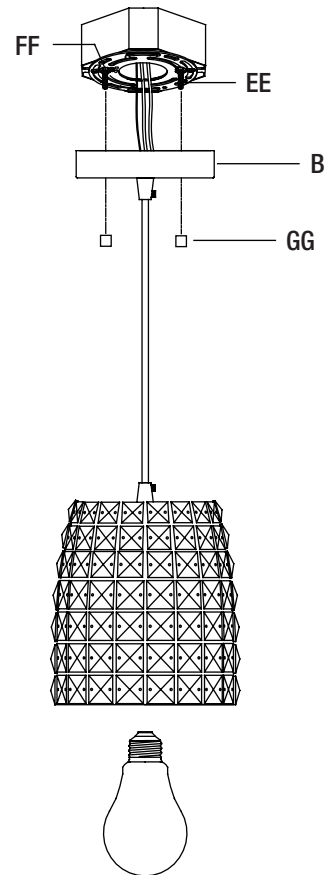

Care and Cleaning

- To clean the outside of the fixture, use a dry or slightly dampened clean cloth (use clean water, never a solvent) to wipe the shade and surface of the fixture.
- To clean the inside of the fixture, first disconnect power to the fixture by turning off the circuit breaker or by removing the fuse at the fuse box. Next, use a dry or slightly dampened clean cloth (use clean water, never a solvent) to wipe the inside shade and interior surface of the fixture.
- Do not use any cleaner with chemicals, solvents, or harsh abrasives. Use only a dry, soft cloth to dust or wipe carefully.

Troubleshooting

Problem	Possible Cause	Solution
□ The bulb will not light.	□ The bulb is burned out.	□ Replace the light bulb.
	□ The power is off.	□ Ensure that the power supply is turned on.
	□ The circuit breaker is off.	□ Ensure that the circuit breaker is set to the ON position.
□ The fuse blows or the circuit breaker trips when the light is turned on.	<ul style="list-style-type: none"> □ There are too many items on one circuit. □ There is a faulty wire connection. 	<ul style="list-style-type: none"> □ Unplug the other items on the circuit. □ Check the wire connections. □ Contact a qualified electrician or call the Customer Service Team at 1-800-986-3460.

HOME DECORATORS COLLECTION

Questions, problems, missing parts? Before returning to the store,
call Home Decorators Collection Customer Service
8 a.m. - 7 p.m., EST, Monday - Friday, 9 a.m. - 6 p.m., EST, Saturday

1-800-986-3460

[HOMEDEPOT.COM/HOMEDECORATORS](https://www.homedepot.com/homedecorators)

Retain this manual for future use.