



WGen550

Portable Generator
5500 Running Watts | 6850 Peak Watts

⚠ WARNING

Operating, servicing and maintaining this equipment can expose you to chemicals including engine exhaust, carbon monoxide, phthalates, and lead, which are known to the State of California to cause cancer and birth defects or other reproductive harm. To minimize exposure, avoid breathing exhaust, do not idle the engine except as necessary, service your equipment in a well-ventilated area and wear gloves or wash your hands frequently when servicing your equipment. For more information go to www.P65Warnings.ca.gov.

DISCLAIMERS:

All information, illustrations and specifications in this manual are based on the latest information available at the time of publishing. The illustrations used in this manual are intended as representative reference views only. Moreover, because of our continuous product improvement policy, we may modify information, illustrations and/or specifications to explain and/or exemplify a product, service or maintenance improvement. We reserve the right to make any change at any time without notice. Some images may vary depending upon which model is shown.

ALL RIGHTS RESERVED:

No part of this publication may be reproduced or used in any form by any means – graphic, electronic or mechanical, including photocopying, recording, taping or information storage and retrieval systems – without the written permission of MWE Investments LLC.

⚠ DANGER



This manual contains important instructions for operating this generator. For your safety and the safety of others, be sure to read this manual thoroughly before operating the generator. Failure to properly follow all instructions and precautions can cause you and others to be seriously hurt or killed.

WGen5500 TECHNICAL SPECIFICATIONS

Model Number	Running Watts	Peak Watts	Fuel Tank Size (L/G)	Rated Speed (RPM)	Ignition Type	Spark plug	Engine Disp (cc)	Stroke X Bore	Oil Capacity (L)	Oil Type	THD
WGen5500	5500	6850	25/6.6	3600	TCI	F7TC	420	66X90	1.10	10W30	<23%

NOTICE

Even with a carburetor modification, engine horsepower will decrease about 3.5% for each 300 meter (1,000 foot) increase in altitude. The effect of altitude on horsepower will be greater if no carburetor modification is made. A decrease in engine horsepower will decrease the power output of the generator. Contact our service team to order altitude kits.

FOR YOUR RECORDS:

Date of Purchase:	
Generator Model Number:	
Purchased from Store/Dealer:	
Generator Serial Number:	

HAVE QUESTIONS? Email us at service@wpowereq.com or call 1-855-944-3571

IMPORTANT: KEEP YOUR PURCHASE RECEIPT TO ENSURE TROUBLE-FREE WARRANTY COVERAGE.

PRODUCT REGISTRATION

To ensure trouble-free warranty coverage, it is important you register your Westinghouse generator. You can register your generator by either:

1. Filling in the product registration form below and mailing to:

Product Registration
 MWE Investments LLC
 777 Manor Park Drive
 Columbus, Ohio 43228

2. Registering your product Online at wpowereq.com/register
 To register your generator you will need to locate the serial number:

WHERE IS MY SERIAL NUMBER?

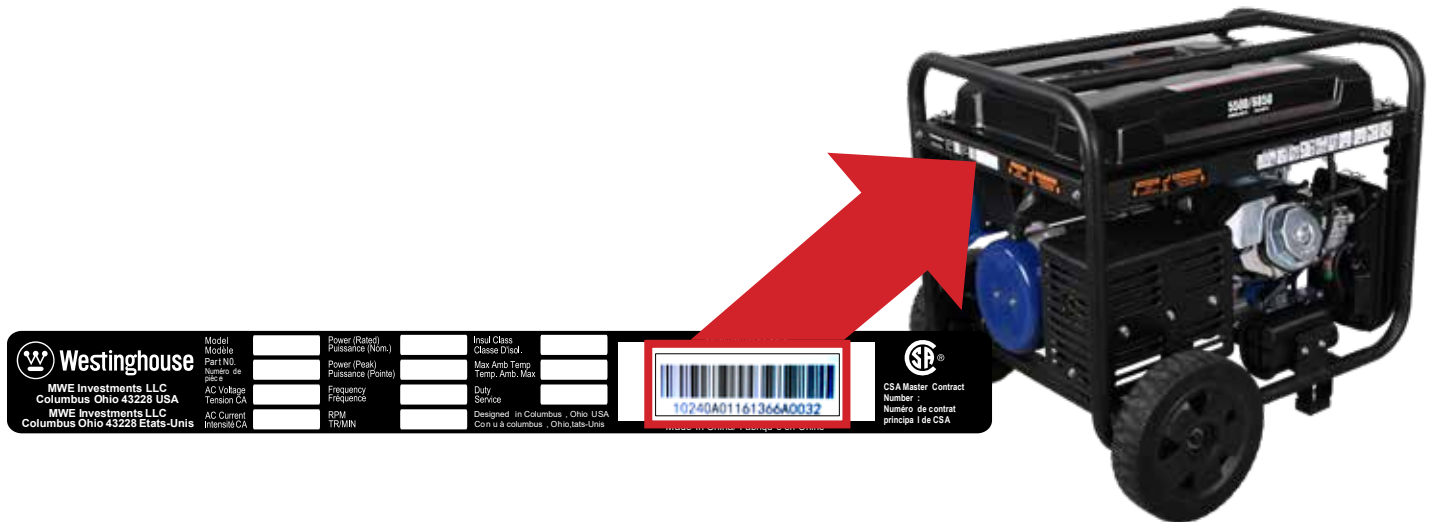

WESTINGHOUSE PRODUCT REGISTRATION FORM

PERSONAL INFORMATION

GENERATOR INFORMATION

First Name: _____ Model Number: _____

Last Name: _____ Serial Number: _____

Street Address: _____ Date Purchased: _____

Street Address: _____ Purchased From: _____

City, State, ZIP: _____

Country: _____

Phone Number: _____

E-Mail: _____



TABLE OF CONTENTS

WGEN5500 TECHNICAL SPECIFICATIONS	2	MAINTENANCE	20
PRODUCT REGISTRATION	3	Maintenance Schedule	20
Locate Serial Number	3	Inspecting and Cleaning the Spark Arrestor	21
Product Registration	3	Draining the Carburetor Float Bowl	21
Product Registration Form	3	Engine Oil Maintenance	22
SAFETY	5	Engine Oil Specification	22
Safety Definitions	5	Checking Engine Oil	22
Safety Symbol Definitions	5	Adding Engine Oil	22
General Safety Rules	6	Changing Engine Oil	23
Safety Labels and Decals	7	Air Filter Maintenance	23
UNPACKING	9	Cleaning the Air Filter	23
What Comes in the Box	9	Spark Plug Maintenance	24
Wheel Kit Accessories Box	9	Checking and Adjusting Valve Lash	25
ASSEMBLY	10	Testing GFCI Outlets	25
Installing Wheels and Feet	10	Cleaning the Generator	25
FEATURES	11	Storage	26
Generator Features	11	TROUBLE SHOOTING	26
Control Panel Features	13	EXPLODED AND ENGINE VIEWS	28
OPERATION	14	WGen5500 Exploded View	28
Before Starting the Generator	14	WGen5500 Engine View	30
Altitude Conversion Kit	14	SCHEMATICS	32
Power Cord	15	WGen5500 Schematic	32
Using Extension Cords	15	GENERATOR SPECIFICATIONS	33
Using Westinghouse Power Cord	15		
Transfer Switch Connections	16		
How to Float the Neutral Ground	16		
Engine Fluids and Fuel	16		
Adding Gasoline to the Fuel Tank	17		
Power Output and Demand	18		
Starting the Generator	18		
Manual Start	18		
Stopping the Generator	19		
Normal Operation	19		
During an Emergency	19		

SAFETY

SAFETY DEFINITIONS

The words DANGER, WARNING, CAUTION and NOTICE are used throughout this manual to highlight important information. Be certain that the meanings of these alerts are known to all who work on or near the equipment.



This safety alert symbol appears with most safety statements. It means attention, become alert, your safety is involved! Please read and abide by the message that follows the safety alerts symbol.

DANGER

Indicates a hazardous situation which, if not avoided, *will* result in death or serious injury.

WARNING

Indicates a hazardous situation which, if not avoided, *could* result in death or serious injury.

CAUTION

Indicates a hazardous situation which, if not avoided, *could* result in minor or moderate injury.

NOTICE

Indicates a situation which can cause damage to the generator, personal property and/or the environment, or cause the equipment to operate improperly.

NOTE: Indicates a procedure, practice or condition that should be followed in order for the generator to function in the manner intended.

SAFETY SYMBOL DEFINITIONS

Symbol	Description
	Safety Alert Symbol
	Asphyxiation Hazard
	Burn Hazard
	Burst/Pressure Hazard
	Don't leave tools in the area
	Electrical Shock Hazard
	Explosion Hazard
	Fire Hazard
	Lifting Hazard
	Pinch-Point Hazard
	Read Manufacturer's Instructions
	Read Safety Messages Before Proceeding
	Wear Personal Protective Equipment (PPE)

SAFETY

GENERAL SAFETY RULES

DANGER



Never use the generator in a location that is wet or damp. Never expose the generator to rain, snow, water spray or standing water while in use. Protect the generator from all hazardous weather conditions. Moisture or ice can cause a short circuit or other malfunction in the electrical circuit.



Never operate the generator in an enclosed area. Engine exhaust contains carbon monoxide. Only operate the generator outside and away from windows, doors and vents.

WARNING



- Voltage produced by the generator could result in death or serious injury.
- Never operate the generator in rain or a flood plain unless proper precautions are taken to avoid being subject to rain or a flood.
 - Never use worn or damaged extension cords.
 - Always have a licensed electrician connect the generator to the utility circuit.
 - Never touch an operating generator if the generator is wet or if you have wet hands.
 - Never operate the generator in highly conductive areas such as around metal decking or steel works.
 - Always use grounded extension cords. Always use three-wire or double-insulated power tools.
 - Never touch live terminals or bare wires while the generator is operating.
 - Be sure the generator is properly grounded before operating.

WARNING



- Gasoline and gasoline vapors are extremely flammable and explosive under certain conditions.
- Always refuel the generator outdoors, in a well-ventilated area.
 - Never remove the fuel cap with the engine running.
 - Never refuel the generator while the engine is running. Always turn engine off and allow the generator to cool before refueling.
 - Only fill fuel tank with gasoline.
 - Keep sparks, open flames or other form of ignition (such as match, cigarette, static electric source) away when refueling.
 - Never overfill the fuel tank. Leave room for fuel to expand. Overfilling the fuel tank can result in a sudden overflow of gasoline and result in spilled gasoline coming in contact with HOT surfaces. Spilled fuel can ignite. If fuel is spilled on the generator, wipe up any spills immediately. Dispose of rag properly. Allow area of spilled fuel to dry before operating the generator.
 - Wear eye protection while refueling.
 - Never use gasoline as a cleaning agent.
 - Store any containers containing gasoline in a well-ventilated area, away from any combustibles or source of ignition.
 - Check for fuel leaks after refueling. Never operate the engine if a fuel leak is discovered.

WARNING



Never operate the generator if powered items overheat, electrical output drops, there is sparking, flames or smoke coming from the generator, or if the receptacles are damaged.



Never use the generator to power medical support equipment.



Always remove any tools or other service equipment used during maintenance from the generator before operating.

NOTICE

Never modify the generator.

Never operate the generator if it vibrates at high levels, if engine speed changes greatly or if the engine misfires often.

Always disconnect tools or appliances from the generator before starting.

SAFETY

SAFETY LABELS AND DECALS

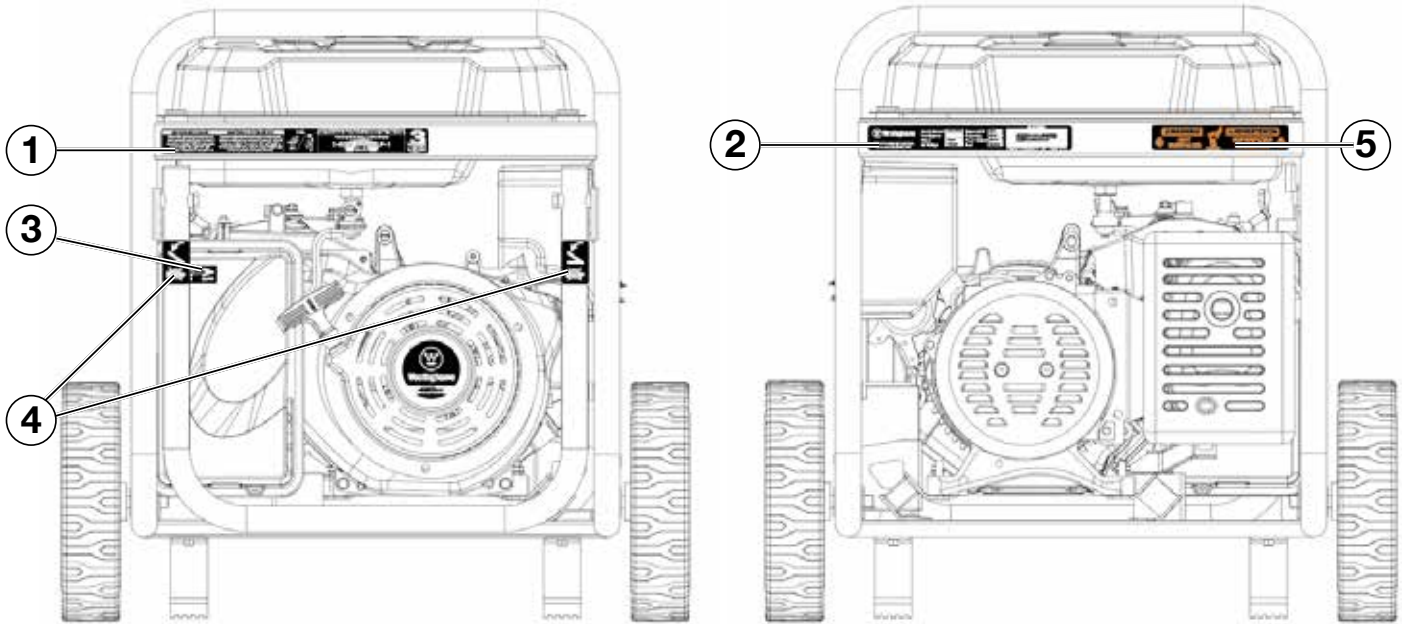

1	MAINTAIN AIR CLEANER	MANTENGA EL FILTRO DE AIRE		FOR TECHNICAL ASSISTANCE or SERVICE CALL TOLL FREE Para la ayuda técnica y servicio llamada 1-855-944-3571	
	Rinse with cleansing solvent and dry once every 50 hours (every 10 hours if operating in dusty conditions) and then immerse in clean engine oil until saturated. Squeeze out excessive oil.	Limpielo según las instrucciones en el manual del usuario y séquelo una vez cada 50 horas (o cada 10 horas en condiciones cuando haya mucho polvo) entonces sumérgalo en aceite de motor limpio hasta saturarse, exprima el aceite de sobra.			

2	Westinghouse MWE Investments LLC Columbus Ohio 43228 USA MWE Investments LLC Columbus Ohio 43228 Etats-Unis	Modelo	Power (Rated)	Inul Class	Serial No./No. de Série	CSA Master Contract Number : Numéro de contrat principal de CSA
		Part No./Número de pieza	Power (Peak)	Max Amb Temp	SERIAL NUMBER	
	AC Voltage	Putissance (Pointe)	Temp, Amb, Max			
	Tension CA	Frequency	Duty Service			
	AC Current	Frequencia	Designed in Columbus, Ohio USA			
	Intensité CA	TR/MIN	Conçu à Columbus, Ohio, États-Unis			
			Made in China/ Fabriqué en Chine			

3

ON = COLD START
OFF = RUN/WARM START

4

5

⚠ WARNING		⚠ ADVERTENCIA
HOT SURFACES		SUPERFICIES CALIENTES

SAFETY

SAFETY LABELS AND DECALS

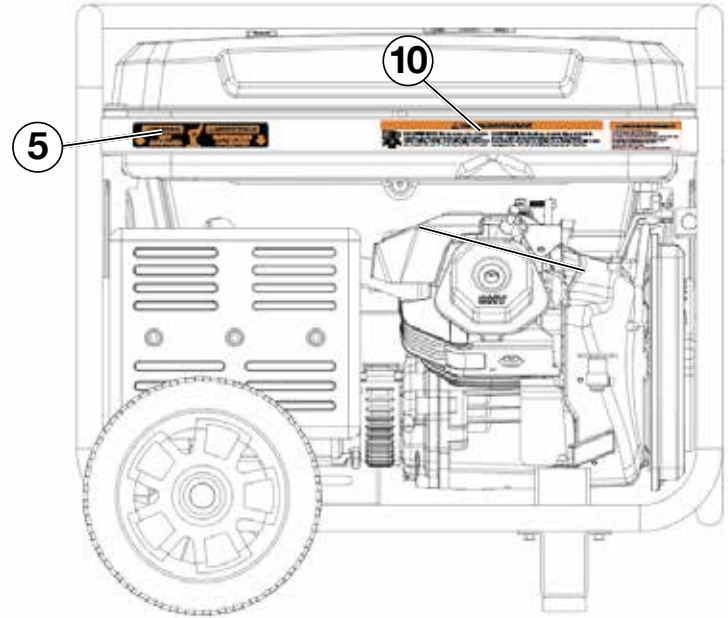
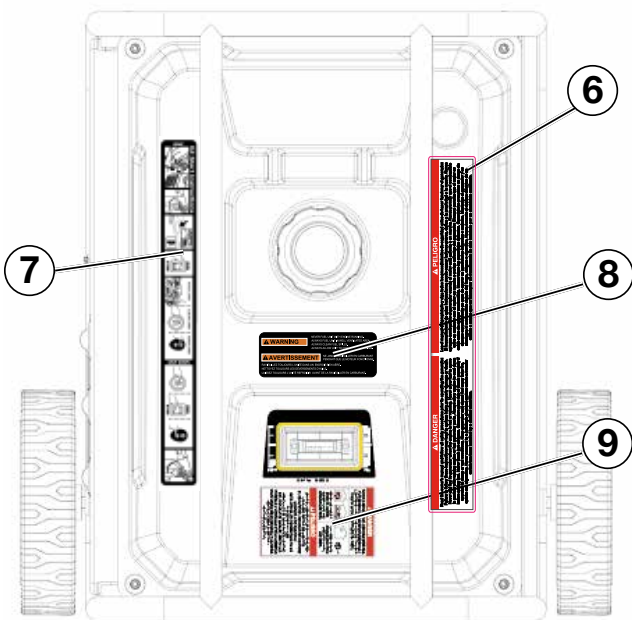

<p>6</p>	<p>⚠ DANGER</p> <p>Read the owner's manual and follow all safety procedures prior to operating the generator. Failure to follow these instructions may lead to serious injury, property damage or death. Never add fuel to generator when the engine is hot or running. Never allow fuel to come in contact with running engine or hot generator parts. Always allow engine to cool down before adding fuel. Never touch hot surfaces. Generators pose risk of shock especially if operated in damp or wet conditions. Keep generator and stored fuel away from fire, sparks and cigarettes. Never connect to a building's electrical system unless a transfer switch has been installed by a certified electrician.</p>	<p>⚠ PELIGRO</p> <p>Lea el manual del propietario y siga todos los procedimientos de seguridad antes de hacer funcionar el generador. El incumplimiento de estas instrucciones puede causar lesiones graves, daños a la propiedad o la muerte. Nunca agregue combustible al generador cuando el motor está caliente o en marcha. Nunca permita que el combustible entre en contacto con el motor en marcha o partes calientes del generador. Siempre permita que el motor se enfríe antes de agregar combustible. Nunca toque las superficies calientes. Generadores presentan un riesgo de choque especialmente en caso de operar en condiciones húmedas o mojadas. Mantenga el generador y su almacena el combustible alejado del fuego, chispas o cigarrillos. Nunca conecta al sistema eléctrico de un edificio a menos que un interruptor de transferencia ha sido instalado por un electricista certificado.</p>
-----------------	---	---

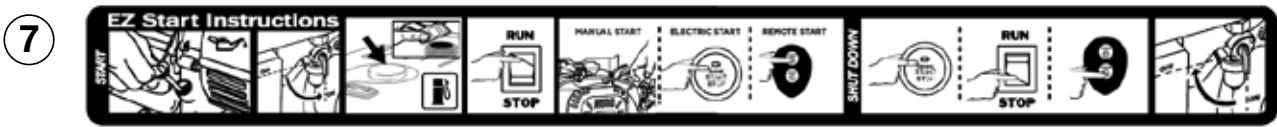

8

⚠ WARNING NEVER FUEL UNIT WITH ENGINE RUNNING. ALWAYS FUEL UNIT IN WELL VENTILATED AREA. ALWAYS CLEAN FUEL SPILLS. ALWAYS ALLOW UNIT TO COOL BEFORE FUELING.

⚠ AVERTISSEMENT NE JAMAIS RAVITAILLER EN CARBURANT PENDANT QUE LE MOTEUR FONCTIONNE. RAVITAILLER TOUJOURS L'UNITÉ DANS UN ENDROIT BIEN AÉRÉ. NETTOYEZ TOUJOURS LES DÉVERSEMENTS D'HUILE. LAISSEZ TOUJOURS L'UNITÉ REFRIGÉRER AVANT DE LA RAVITAILLER EN CARBURANT.

9

⚠ DANGER USING A GENERATOR INDOORS CAN KILL YOU IN MINUTES. GENERATOR EXHAUST CONTAINS CARBON MONOXIDE. THIS IS A POISON YOU CANNOT SEE OR SMELL.

NEVER USE INSIDE A HOME OR GARAGE, EVEN IF DOORS AND WINDOWS ARE OPEN.

ONLY USE OUTSIDE AND FAR AWAY FROM WINDOWS, DOORS, AND VENTS.

⚠ PELIGRO USAR EL GENERADOR EN INTERIORES LO PUEDE MATAR EN MINUTOS. EL ESCAPE DEL GENERADOR CONTIENE MONÓXIDO DE CARBONO. ESTE GAS ES UN VENENO QUE NO SE PUEDE VER NI OLER.

NUNCA USE EL GENERADOR DENTRO DEL HOGAR O EL GARAJE, AUN SI LAS PUERTAS Y VENTANAS ESTÁN ABIERTAS. SOLO USELO EN EXTERIORES Y LEJOS DE VENTILACIONES, PUERTAS Y VENTANAS ABIERTAS.

10

⚠ WARNING/AVERTISSEMENT

TOXIC FUMES HAZARD. Running engines gives off carbon monoxide, an odorless poisonous gas that can cause nausea, fainting, or death. Do not start engine indoors or in an enclosed area, even if the windows and doors are open.

DANGER TOXIQUE. Faire fonctionner un moteur dégage de l'oxyde de carbone, un gaz inodore toxique qui peut provoquer la nausée, évanouissement ou la mort. Ne démarrer pas le moteur à l'intérieur ou dans une espace clos, même si les fenêtres et les portes sont ouvertes.



⚠ WARNING/AVERTISSEMENT

FOR ELECTRICAL EQUIPMENT ONLY
POUR MATÉRIEL ÉLECTRIQUE SEULEMENT

FOR USE IN A WEATHER-PROTECTED WELL VENTILATED AREA
EMPLOYER UNOQUEMENT DANS UN ENDROIT BIEN AÉRÉ
À L'ABRI DES INTÉMPÉRIES ET BIEN AÉRÉ

NEUTRAL BONDED TO FRAME
NEUTRE MIS À LA BASSE À LA CARCASSE DU MOTEUR

UNPACKING

⚠ CAUTION	
	Always have assistance when lifting the generator. The generator is heavy; lifting it could cause bodily harm.
	Avoid cutting on or near staples to prevent personal injury.

Tools required – box cutter or similar device.

1. Carefully cut the packing tape on top of the carton.
2. Fold back top flaps to reveal the manual.
3. Remove the Wheel Kit Accessories cardboard box.
4. Carefully cut two sides of the carton to remove the generator.

WHAT COMES IN THE BOX

Manual
Quick Start Guide/Maintenance Schedule
1.1 Liter Bottle of SAE 10W30 Oil (1)
Spark Plug Socket Wrench (1)
Wheel Kit Accessories Box
Funnel (1)

WHEEL KIT ACCESSORIES BOX

Open the Wheel Kit Accessories box and verify the contents against the list right. If any parts are missing, please locate an authorized Westinghouse Generator dealer at service@wpowereq.com or call 1-855-944-3571.

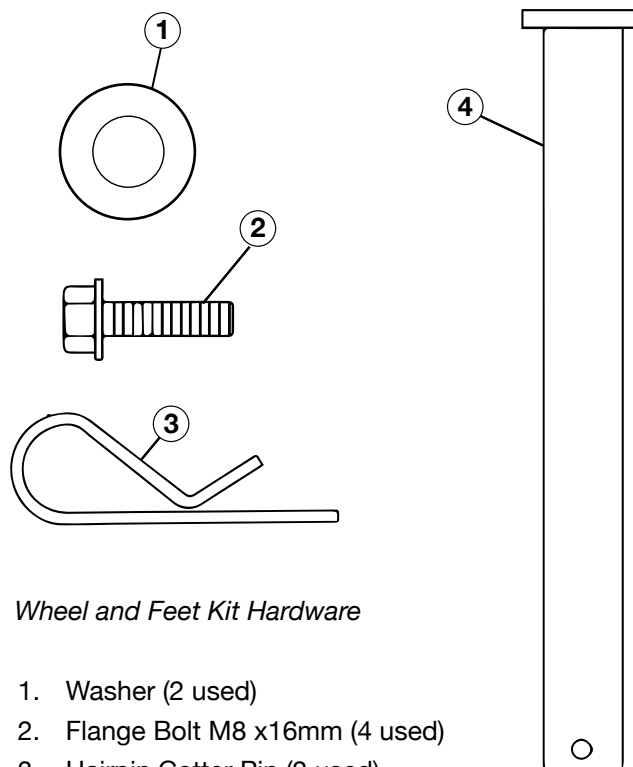

Wheel and Feet Kit Hardware

1. Washer (2 used)
2. Flange Bolt M8 x16mm (4 used)
3. Hairpin Cotter Pin (2 used)
4. Wheel Axle Pin (2)



ASSEMBLY

INSTALLING WHEELS AND FEET



BEFORE ASSEMBLING THE GENERATOR, REVIEW THE SAFETY SECTION STARTING ON PAGE 5.

⚠ CAUTION



Never lift the generator without assistance. The generator is heavy and lifting without assistance could result in personal injury.



Never use the handles as a lifting point to support the entire weight of the generator. Only use the handles to move the generator by lifting the handles and using the wheels to move the generator.



Use caution when collapsing the handles. Hands and fingers could get caught and pinched.

NOTICE

Assembling the generator will require lifting the unit on one side. Make sure all engine oil and fuel are drained from the unit prior to assembling. Once assembled, the wheel kit is not intended for on-road use. The wheel kit is designed for use on this generator only.

INSTALLING FEET TO FRAME

1. Place generator on a flat surface.
2. Place a piece of cardboard or other soft material to tip the generator onto, to protect the frame paint and prevent the generator from sliding. Tip the generator onto the side.
3. Install the mounting feet to the frame using the M8 flange bolts included.
1 - Mounting Foot
2 - Flange Bolts M8

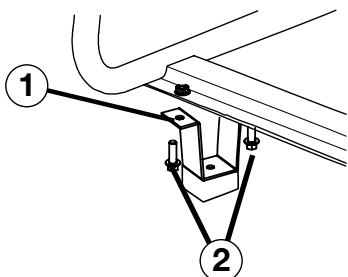

Figure 1 - Assemble Mounting Feet to Frame

INSTALLING WHEELS TO FRAME

1. Insert axle pin through washer and wheel.

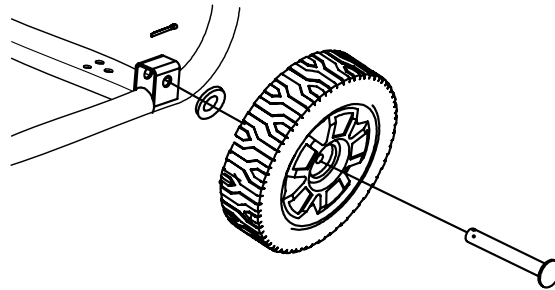

Figure 2 - Wheel Assembly

2. Install the wheel with axle pin through the axle bracket on the frame. The eye of the bolt should be facing toward the inside of the generator.

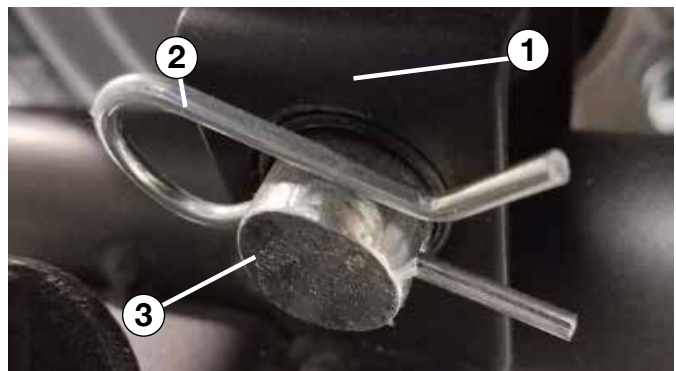

Figure 3 - Assemble Wheel to Frame

3. Install the hairpin cotter through the axle pin to lock it in place.
1 - Axle Bracket
2 - Hairpin Clip
3 - Axle Pin
4. Repeat previous steps on other wheel.

FEATURES



- ① **Engine Control Switch:** Allows fuel to flow to engine and energizes the ignition system.
- ② **Fuel Cap:** Close until clicking sound is heard.
- ③ **Control Panel:** Contains the circuit breakers and outlets.
- ④ **Oil Fill Plug/Dipstick:** Must be removed to add and check oil.
- ⑤ **Oil Drain Plug:** Must be removed to drain engine oil
- ⑥ **Never Flat Wheels:** For easy portability
- ⑦ **Fuel Shut off Valve:** Controls the flow of fuel to the engine.
- ⑧ **Manual Choke:** Choke must be set manually by adjusting choke lever.
- ⑨ **Single Piece Handle:** Includes rubber grip. Allows you to easily push or pull unit with one hand.

FEATURES



- ⑫ **Fuel Gauge:** Indicates fuel level.
- ⑬ **Spark Plug Boot (Wire):** Must be removed when servicing the engine or the spark plug.
- ⑭ **CARB Canister:** Required for models sold into and used in California.
- ⑮ **Muffler and Spark Arrester:** Avoid contact until engine is cooled down. Spark arrester prevents sparks from exiting the muffler. It must be removed for servicing.
- ⑯ **Alternator Cover:** Gain access to alternator wiring.

FEATURES

CONTROL PANEL FEATURES

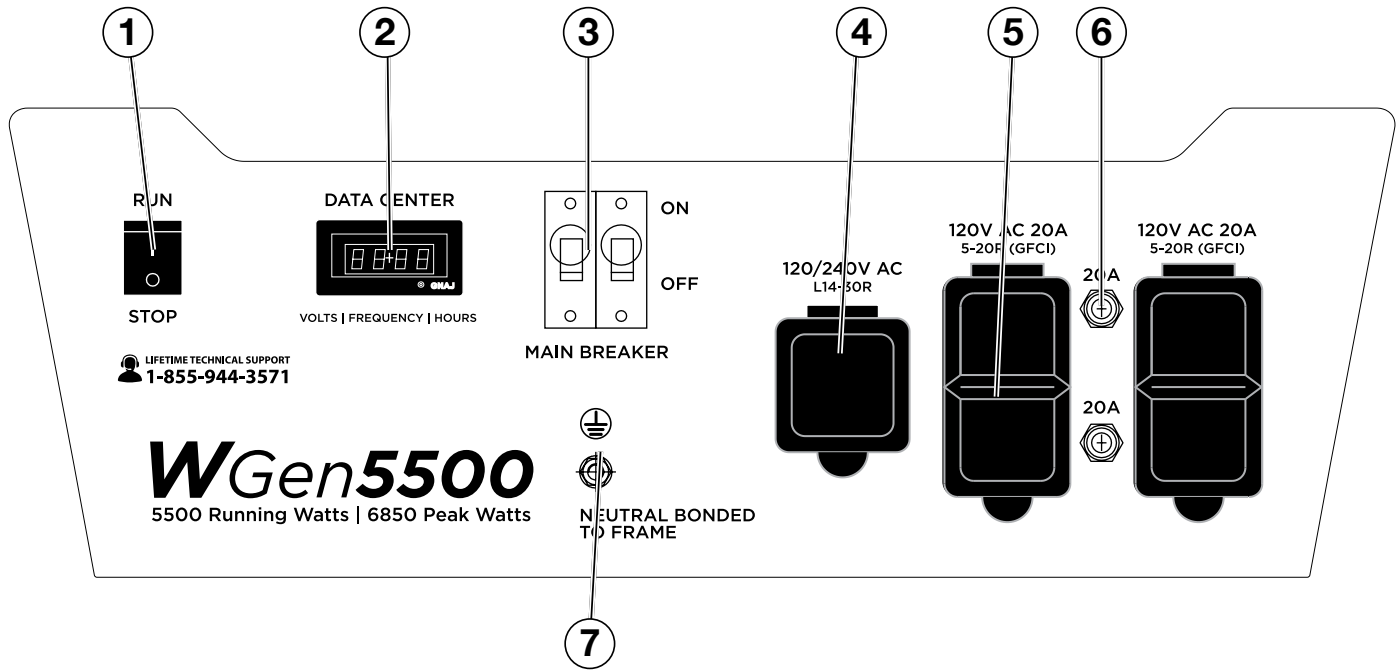

Figure 4 - Control Panel Features

- ① **Engine Control Switch:** Allows fuel to flow to engine and energizes the ignition system.
- ② **Data Center:** The VFT Meter is an LED display that will rotate through volts, frequency, and lifetime run hours. You can press the **MODE** button to cycle through the different displays.

The frequency and voltage can vary +/- 5% and still be within tolerance.

U250	Voltage
F-60	Frequency in hertz
00:07	Lifetime run hours
- ③ **Main Circuit Breaker:** The main circuit breaker controls total output of all outlets to protect the generator.
- ④ **120/240-Volt, 30-Amp Twist Lock Outlet (NEMA L14-30R):** Outlet can supply either 120V or 240V output.
- ⑤ **120-Volt, 20-Amp Duplex GFCI Outlets (NEMA 5-20R):** Each outlet is capable of carrying a maximum of 20 amps on a single receptacle or a combination of both receptacles.
- ⑥ **20-Amp Circuit Breakers:** Each circuit breaker limits the current that can be delivered through the 120-volt duplex outlets to 20amps.
- ⑦ **Ground Terminal:** The ground terminal is used to ground the generator.

OPERATION



BEFORE STARTING THE GENERATOR



BEFORE STARTING THE GENERATOR, REVIEW SAFETY SECTION STARTING ON PAGE 5.

Location Selection – Before starting the generator, avoid exhaust and location hazards by verifying:

- You have selected a location to operate the generator that is outdoors and well ventilated.
- You have selected a location with a level and solid surface on which to place the generator.
- You have selected a location that is at least 15 feet (4.5 m) away from any building, other equipment or combustible material.
- If the generator is located close to a building, make sure it is not located near any windows, doors and/or vents.

⚠ DANGER	
Using a generator indoors CAN KILL YOU IN MINUTES. Generator exhaust contains carbon monoxide. This is a poison you cannot see or smell.	
 	
NEVER use inside a home or garage, EVEN IF doors and windows are open.	Only use OUTSIDE and far away from windows, doors, and vents.
Avoid other generator hazards. READ MANUAL BEFORE USE.	

⚠ WARNING	
	Always operate the generator on a level surface. Placing the generator on non level surfaces can cause the generator to tip over, causing fuel and oil to spill. Spilled fuel can ignite if it comes in contact with an ignition source such as a very hot surface.

NOTICE	
Only operate the generator on a solid, level surface. Operating the generator on a surface with loose material such as sand or grass clippings can cause debris to be ingested by the generator that could: <ul style="list-style-type: none">• Block cooling vents• Block air intake system	

Weather – Never operate your generator outdoors during rain, snow or any combination of weather conditions that could lead to moisture collecting on, in or around the generator.

Dry Surface – Always operate the generator on a dry surface free of any moisture.

No Connected Loads – Make sure the generator has no connected loads before starting it. To ensure there are no connected loads, unplug any electrical extension cords that are plugged into the control panel receptacles.

NOTICE
Starting the generator with loads already applied to it could result in damage to any appliance being powered off the generator during the brief start-up period.

Grounding the Generator – The National Electric Code (NEC), as well as many local electrical codes, may require the generator to be connected to earth ground. The most common application that requires a ground rod is when you are using the generator as a separately derived system to provide back up power to your house. Typically this is when a transfer switch has a switched neutral.

As the generator application has many variables that cannot be determined by the manufacturer of the generator, a licensed electrician will need to determine if a grounding rod is needed.

If a licensed electrician has determine the application requires a ground rod, make sure it is connected to earth ground by connecting the ground terminal on the control panel to earth ground using copper wire (minimum 10 AWG). Consult a qualified electrician for local grounding requirements.

Neutral Bonded: There is a permanent conduct or between the generator (stator winding) and the frame.

⚠ WARNING	
	Be sure the generator is properly connected to earth ground before operating. The generator must be grounded to prevent electrical shock due to faulty appliances.

High Altitude Operation

Engine power is reduced the higher you operate above sea level. Output will be reduced approximately 3.5% for every 1000ft of increased altitude from sea level. This is a natural occurrence and cannot be adjusted by engine. Increased exhaust emissions can also result due to increased fuel mixture. Other issues include hard starting, increased fuel consumption and spark plug fouling. Contact our service team **1-855-944-3571** for altitude part kits.

High Altitude Carburetor Kit Part Number: 140545

OPERATION

POWERCORD

Using Extension Cords

Westinghouse Portable Power assumes no responsibility for the content within this table. The use of this table is the responsibility of the user only. This table is intended for reference only. The results produced by using this table are not guaranteed to be correct or applicable in all situations as the type and construction of cords are highly variable. Always check with local regulations and a licensed electrician prior to installing or connecting an electrical appliance

Extension Cord Wire Gauge Size

AMPS	LENGTH OF EXTENSION CORD (ft)								
	10	20	30	40	50	60	80	100	120
5	20	18	16	14	12	12	10	10	8
10	18	16	14	12	12	10	10	8	8
15	16	14	12	12	10	10	8	8	6
20	14	12	12	10	10	8	8	6	6
25	12	12	10	10	8	8	6	6	6
30	12	10	10	8	8	6	6	6	6
35	10	10	8	8	6	6	6	6	6

Using Westinghouse Power Cord

Use the extension cord chart to determine the size of the conductor for extension cord applications. Determine the distance of the generator to the appliance on the top line of the chart. Then select the rated amperage of the generator on the left side of the chart. Where the two meet is the size of the conductor required for the application.

When using the WCG25/WCG20 power cord (sold separate) connect to the 120/240V outlet. The opposite end of the power cord is a fan tail receptacle with 2 green receptacles and 2 red receptacles. Each receptacle is rated at 120 volts AC. To balance the load on the generator's alternator, use the red and green identifiers on the fan tail receptacle. To keep the load balanced, connect the loads so that both color receptacles are used. An example is one in red and one in green. Do not connect 2 in red and none in green, or 2 in green and none in red. If only one color receptacle is used with multiple loads, the alternator may experience an unbalanced load, causing undue vibration to generator.

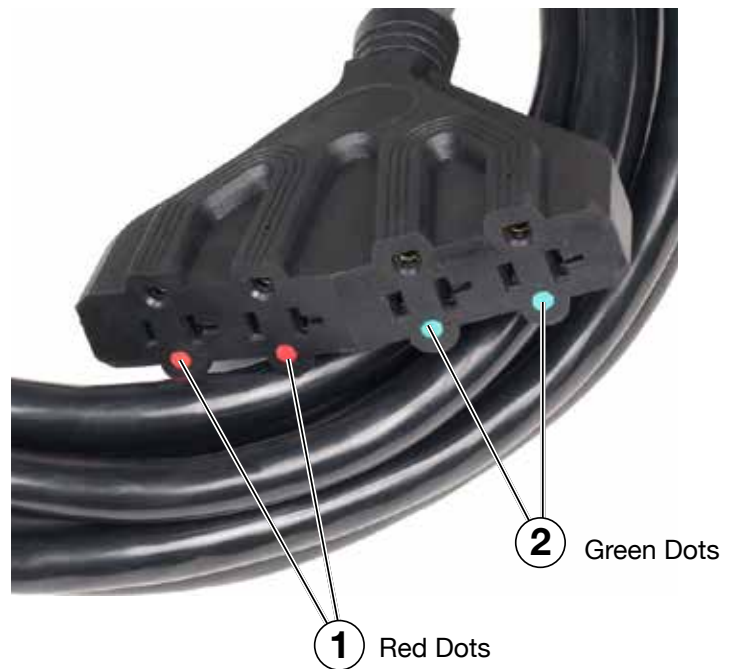

- WCG25/WCG20 Extension Cord

OPERATION

CONNECTING THE GENERATOR TO A BUILDING ELECTRICAL SYSTEM

It is recommended to use a manual transfer switch when connecting directly to a buildings electrical system. Connecting a portable generator to a buildings electrical system must be made in strict compliance with all national and local electrical codes and laws, and be completed by a qualified electrician.

TRANSFER SWITCH CONNECTIONS

The Westinghouse generator is wired with the neutral bonded to ground. If you are connecting your generator to a panel board transfer switch, a licensed electrician will need to consider removing the bonded neutral to ensure proper operation of household GFCI circuits. Begin by removing the alternator cover (16 on page 12). Once the cover is off remove the nut that holds the bonded ground jumper wire (see “2” in Figure 6). Once the nut is removed take the bonded jumper wire off and re-secure the nut. Next remove the screw holding the neutral ground wire (see “1” in Figure 6). Attach the bonded jumper wire (2) to the neutral ground (1) and tighten the screw.

If the bonded neutral is removed the generator must be relabeled as floating neutral on the control panel.

If your generator is equipped with GFCI receptacles, removing the bonded neutral may not allow proper operation of the GFCI receptacles. Always keep the jumper wire in case it is needed for future use when not connected to a transfer switch.

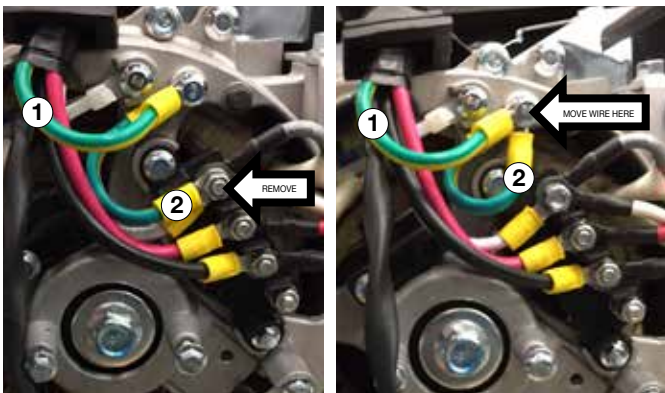

- ① Alternator Neutral Ground Wire (white/Green)
- ② Alternator Bonded Jumper Wire (white/Green)

Figure 6

ADDING / CHECKING ENGINE FLUIDS AND FUEL



BEFORE ADDING/CHECKING ENGINE FLUIDS AND FUEL, REVIEW SAFETY SECTION STARTING ON PAGE 5.

DANGER



Filling the fuel tank with gasoline while the generator is running can cause gasoline to leak and come in contact with hot surfaces that can ignite the gasoline.

Before starting the generator, always check the level of:

- Engine oil
- Gasoline in the fuel tank

Once the generator is started and the engine gets warm, it is not safe to add gasoline to the fuel tank or engine oil to the engine while the engine is running or the engine and muffler are hot.

CHECKING AND / OR ADDING ENGINE OIL

WARNING



Internal pressure can build in the engine crankcase while the engine is running. Removing the oil fill plug/dipstick while the engine is hot can cause extremely hot oil to spray out of the crankcase and can severely burn skin. Allow engine oil to cool for several minutes before removing the oil fill plug/dipstick.

The unit as shipped does not contain oil in the engine. You must add engine oil before starting the generator for the first time. See *Checking Engine Oil* and *Adding Engine Oil* on page 22 for instructions on checking engine oil level and the procedure for adding engine oil.

NOTICE

The engine does not contain engine oil as shipped. Attempting to start the engine can damage engine components. The owner of the generator is responsible to ensure the proper oil level is maintained during the operation of the generator. Failure to maintain the proper oil level can result in engine damage.

OPERATION

ADDING GASOLINE TO THE FUEL TANK

WARNING



Never refuel the generator while the engine is running.



Always turn the engine off and allow the generator to cool before refueling.

Required Gasoline – Only use gasoline that meets the following requirements:

- Unleaded gasoline only
- Gasoline with maximum 10% ethanol added
- Gasoline with an 87 octane rating or higher

Filling the Fuel Tank – Follow the steps below to fill the fuel tank:

1. Shut off the generator.
2. Allow the generator to cool down so all surface areas of the muffler and engine are cool to the touch.
3. Move the generator to a flat surface.
4. Clean area around the fuel cap.
5. Remove the fuel cap by rotating counterclockwise.
6. Slowly add gasoline into the fuel tank. Be very careful not to overfill the tank. The gasoline level should NOT be higher than the filler neck (see Figure 7).
7. Install the fuel cap by rotating clockwise until you hear a click, indicating the cap is completely installed.

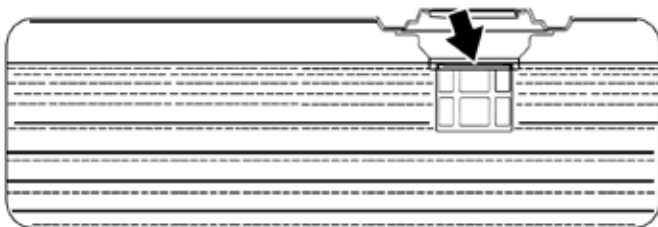

Figure 7 - Maximum Gasoline Fill Level

CAUTION



Avoid prolonged skin contact with gasoline. Avoid prolonged breathing of gasoline vapors.

BEFORE STARTING THE GENERATOR



BEFORE STARTING THE GENERATOR, REVIEW SAFETY SECTION STARTING ON PAGE 5.

Before attempting to start the generator, verify the following:

- The engine is filled with engine oil. See *Checking Engine Oil* on page 22.
- The generator is situated in a proper location (*Location Selection* on page 14).
- The generator is on a dry surface (*Weather and Dry Surface* on page 14).
- All loads are disconnected from the generator (*No Connected Loads* on page 14).
- The generator is properly grounded the Generator (page 14).

DANGER



Never use the generator in a location that is wet or damp. Never expose the generator to rain, snow, water spray or standing water while in use. Protect the generator from all hazardous weather conditions. Moisture or ice can cause a short circuit or other malfunction in the electrical circuit.



Never operate the generator in an enclosed area. Engine exhaust contains carbon monoxide. Only operate the generator outside and away from windows, doors and vents.

NOTICE

The engine is equipped with a low oil shutdown switch. If the oil level becomes low, the engine may shut down and not start until the oil is filled to the proper level. Poor oil quality may interfere with the operation of the low oil shutdown switch.

The owner of the generator is responsible to ensure the proper oil level is maintained during the operation of the generator. Failure to maintain the proper oil level can result in engine damage.

NOTICE

DO NOT connect 240V loads to a 120V receptacles. DO NOT connect 3-phase loads to the generator. DO NOT connect 50Hz loads to the generator. Let engine stabilize and warm up for a few minutes before adding load.

OPERATION

POWER OUTPUT AND DEMAND

The generator should not be run completely unloaded for extended periods otherwise the engine may be damaged. It is recommended that the generator should always be operated with at least one-third of its rated 120-Volt AC power output. 120-Volt AC devices have two different electric power demands that must be taken into consideration, namely the running power and the starting/peak power. Both are measured in Watts (typically abbreviated as “W”).

The steady state continuous load is the running power demand and this is often marked on the device near its model number or serial number. Sometimes the device might only be marked with its voltage (i.e. 120 V) and current draw (e.g. 6 Amp or 6 A), in which case the running power demand in Watts can be obtained by multiplying the voltage times the current, e.g. $120\text{ V} \times 20\text{ A} = 2,400\text{ W}$.

Simple resistive 120-Volt AC devices such as incandescent bulbs, toasters, heaters, etc. have no extra power demand when starting, and so their starting power demands are the same as their running power demands.

More complex 120-Volt AC devices containing inductive or capacitive elements such as electric motors have a momentary extra power demand when starting, which can be up to seven times the running power demand or more. Manufacturers of such devices rarely publish this starting power demand and so it's often necessary to estimate it. A rule of thumb for devices fitted with an electric motor is to apply a starting power multiplier of 1.2 for small hand-held or portable devices and a value of 3.5 for larger stationary devices. For example, a 900 W angle grinder can be assumed to have a starting power demand of at least $1.2 \times 900\text{ W}$, which equals 1,080 W. Similarly, a 1,650 W air compressor can be assumed to have a starting power demand of at least $3.5 \times 1,650\text{ W}$, which equals 5,775 W. To prevent overloading of the generator's 120-Volt AC system:

1. Add up the running power demand of all the 120-Volt AC devices that will be connected to the generator at one time. This total must not be greater than the generator's specified running power output.
2. Add up the running power demand again, but for the largest motor-driven device use the value of its starting power demand instead of its running power demand. This total must not be greater than the generator's specified starting power output.
3. The total running power demand of all the devices that will be connected to any one of the generator's outlets must not exceed the generator's specified running power output or 3,700 W, whichever is the lesser.

STARTING THE GENERATOR

Be sure to check oil levels before starting. If it is the first time starting make sure to add oil (see *Adding Engine Oil* page 22).

1. Make sure nothing is plugged into power outlets
2. Make sure the circuit breakers are properly set (see Figure 8).

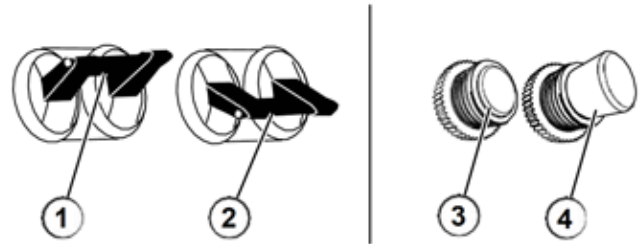

Figure 8 - Breakers

- ① 240/120V Main Circuit Breaker Operating Position
- ② 240/120V Main Circuit Breaker Tripped Position
- ③ 120V Circuit Breaker Operating Position
- ④ 120V Circuit Breaker Tripped Position

3. Move the fuel shutoff valve to the **ON** position (see Figure 9).

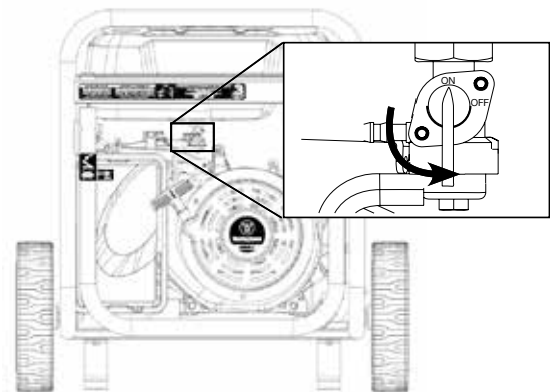

Figure 9 - Fuel Shut Off - ON

4. If the engine is cold, move the choke lever to the **ON** position (see Figure 10 below). If the engine is warm turn choke **OFF**.

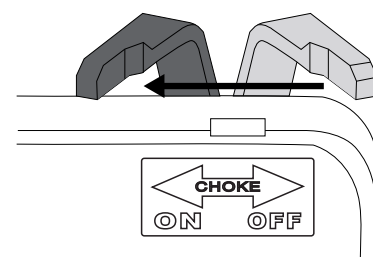

Figure 10 - Choke - ON

OPERATION

5. Push the engine control switch into the **RUN** position (see Figure 11).

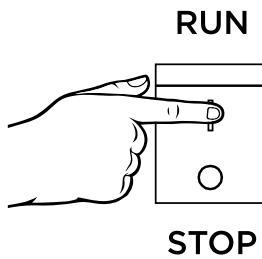

Figure 11 - Engine Control Switch - RUN

6. Firmly grasp and pull the recoil handle slowly until you feel increased resistance. At this point, apply a rapid pull while pulling up and slightly away from the generator (see Figure 12).

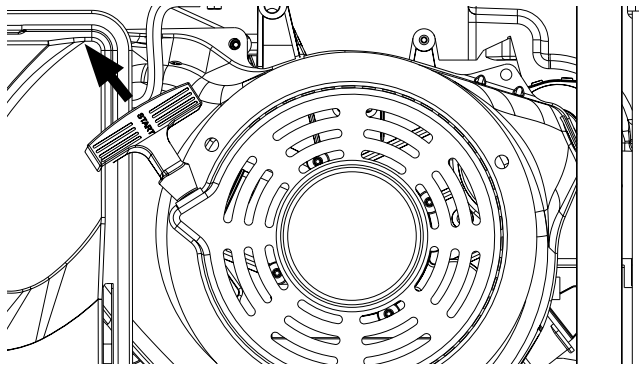
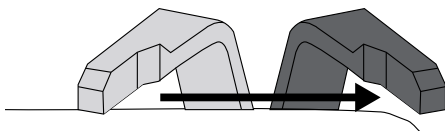

Figure 12 - Engine Recoil Handle - Pull

7. As the engine starts and stabilizes, gradually move the choke lever back to the **OFF** position.



8. Plug in electric devices.

STOPPING THE GENERATOR

Normal Operation

During normal operation, use the following steps to stop your generator:

1. Remove any connected loads from the control panel receptacles.
2. Allow the generator to run at "no load" to reduce and stabilize engine and alternator temperatures.
3. Position the engine control switch to **STOP**.

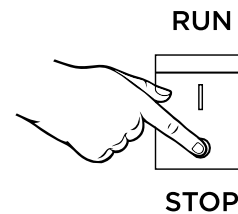

Figure 13 - Stopping the generator

NOTE If you plan to store the generator after use, stop the generator by turning the fuel shutoff valve to the **OFF** position and allow the fuel to be consumed from the carburetor.

4. Turn the fuel shutoff valve to the **OFF** position.

During an Emergency

If there is an emergency and the generator must be stopped quickly, position the engine control switch to the **STOP** position immediately.

MAINTENANCE



BEFORE PERFORMING MAINTENANCE ON THE GENERATOR, REVIEW THE SAFETY SECTION STARTING ON PAGE 5, AS WELL AS THE FOLLOWING SAFETY MESSAGES.

⚠ WARNING



Avoid accidentally starting the generator during maintenance by removing the spark plug boot from the spark plug. For electric start generators, also disconnect the battery cables from the battery (disconnect the black negative (-) cable first) and place the cables away from the battery posts to avoid arcing.



Allow hot components to cool to the touch prior to performing any maintenance procedure.



Internal pressure can build in the engine crankcase while the engine is running. Removing the oil fill plug/ dipstick while the engine is hot can cause extremely hot oil to spray out of the crankcase and can severely burn skin. Allow engine oil to cool for several minutes before removing the oil fill plug/dipstick.



Always perform maintenance in a well-ventilated area. Gasoline fuel and fuel vapors are extremely flammable and can ignite under certain conditions.

MAINTENANCE SCHEDULE

⚠ WARNING



Failure to perform periodic maintenance or not following maintenance procedures can cause the generator to malfunction and could result in death or serious injury.

NOTICE

Periodic maintenance intervals vary depending on generator operating conditions. Operating the generator under severe conditions, such as sustained high-load, high-temperature, or unusually wet or dusty environments, will require more frequent periodic maintenance. The intervals listed in the maintenance schedule should be treated only as a general guideline.

⚠ CAUTION



Avoid skin contact with engine oil or gasoline. Prolonged skin contact with engine oil or gasoline can be harmful. Frequent and prolonged contact with engine oil may cause skin cancer. Take protective measures and wear protective clothing and equipment. Wash all exposed skin with soap and water.

Following the maintenance schedule is important to keep the generator in good operating condition. The following is a summary of maintenance items by periodic maintenance intervals.

TABLE 1: MAINTENANCE SCHEDULE - OWNER PERFORMED

Maintenance Item	Before Every Use	After First 20 Hours or First Month of Use	After 50 Hours of Use or Every 6 Months	After 100 Hour of Use or Every 6 Months	After 300 Hours of Use or Every Year
Engine Oil	Check Level	Change	Change	-	-
Cooling Features	Check/Clean	-	-	-	-
Air Filter	Check	-	Clean*	-	Replace
Spark Plug	-	-	-	Check/Clean	Replace
Spark Arrestor	-	-	-	Check/Clean	-

*Service more frequently if operating in dry and dusty conditions

MAINTENANCE

TABLE 2: MAINTENANCE SCHEDULE - AUTHORIZED WESTINGHOUSE SERVICE DEALER PERFORMED

Maintenance Item	Before Every Use	After First 20 Hours or First Month of Use	After 50 Hours of Use or Every 6 Months	After 100 Hour of Use or Every 6 Months	After 300 Hours of Use or Every Year
Valve Clearance	-	-	-	-	Check/Adjust
Fuel Filter	-	-	-	Check/Clean	-
Idle Speed	-	-	-	-	Check/Adjust

CLEANING THE SPARK ARRESTOR

⚠ WARNING

 Hot Surfaces. When operating machine, do not touch hot surfaces. Keep machine away from combustibles during use. Hot surfaces could result in severe burns or fire.

Check and clean the spark arrestor after every 100 hours of use or 6 months.

1. Generator must be cold to perform this maintenance.
2. Move the inverter to a flat, level surface.
3. Remove the 6 screws holding the muffler cover in place (see Figure 14).

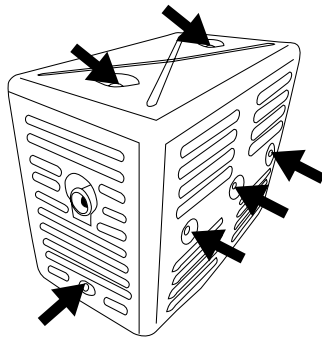

Figure 14: Remove screws holding muffler cover

4. Once the cover is removed, locate the screw on the tip of the muffler and remove. Pull the spark arrestor out of the muffler. (see Figure 15).

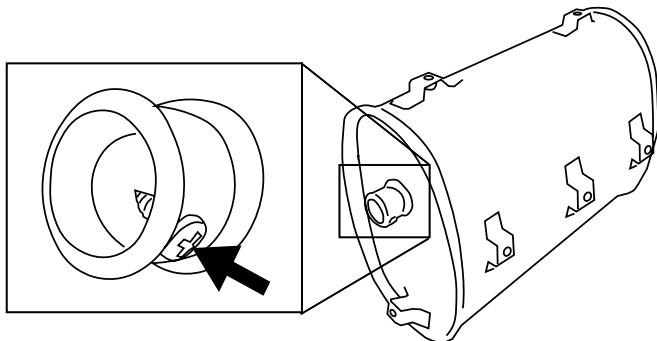

Figure 15: Remove spark arrestor

5. If the spark arrestor screen shows signs of wear (rips, tears or large openings in the screen), replace the spark arrestor screen. **NOTE:** Only use Westinghouse spark arrestors as replacements.
6. If screen is not torn then clean using a wire brush, commercial solvent, or compressed air. Remove any dirt and debris that may have collected on the spark arrestor screen (see Figure 16).

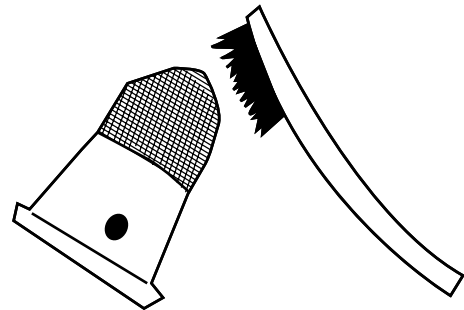
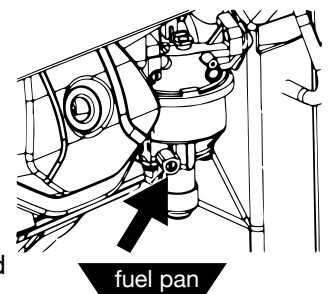

Figure 16: Clean spark arrestor

7. Install the spark arrestor back into the muffler. Make sure to fully push it in so that it is tight on the tip of the muffler.
8. Replace the muffler cover and tighten all 6 screws.

DRAINING CARBURETOR FLOAT BOWL

1. Make sure the generator is off and you are away from any open flames.
2. Place pan (or suitable container) under the carburetor assembly.
3. Loosen screw at bottom of the bowl and allow gas to drain out.
4. After all the gas has drained out, tighten the screw.



MAINTENANCE

ENGINE OIL MAINTENANCE

Engine Oil Specification

1. Only use the engine oil specified in Figure 17.
2. Only use 4-stroke/cycle engine oil. **NEVER USE 2-STROKE/CYCLE OIL.** Synthetic oil is an acceptable substitute for conventional oil.

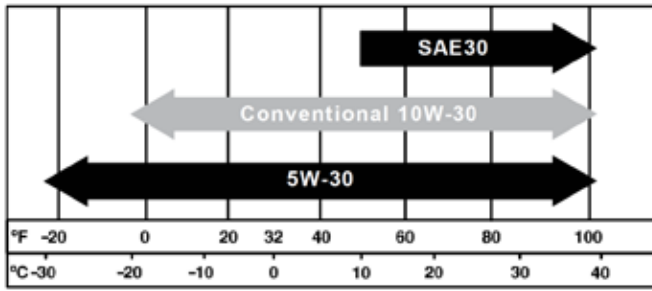

Figure 17 - Recommended Oil

CHECKING ENGINE OIL

NOTICE

Always maintain proper engine oil level. Failure to maintain proper engine oil level could result in severe damage to the engine and/or shorten the life of the engine. Always use the specified engine oil. Failure to use the specified engine oil can cause accelerated wear and/or shorten the life of the engine.

Engine oil level should be checked before every use.

1. Always operate or maintain the generator on a flat surface.
2. Stop engine if running.
3. Let engine sit and cool for several minutes (allow crankcase pressure to equalize).
4. With a damp rag, clean around the oil fill plug/dipstick.
5. Remove oil fill plug/dipstick (see Figure 18 below).

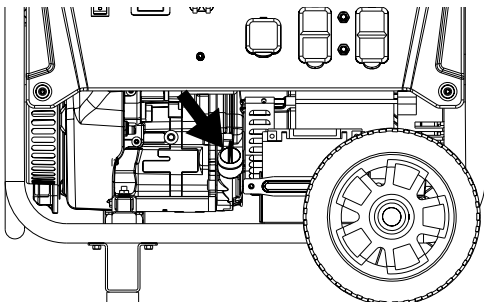

Figure 18 - Oil Fill Plug/Dipstick

6. Check oil level: When checking the engine oil, remove the oil fill plug/dipstick and wipe it clean. Thread the oil fill plug/dipstick all the way back in and then remove and check the oil level on the oil fill plug/dipstick.
 - **Acceptable Oil Level** – Oil is visible on the crosshatches between the H and L lines on the oil fill plug/dipstick (see Figure 19).
 - **Low Oil** – Oil is below the L line on the oil fill plug/dipstick.

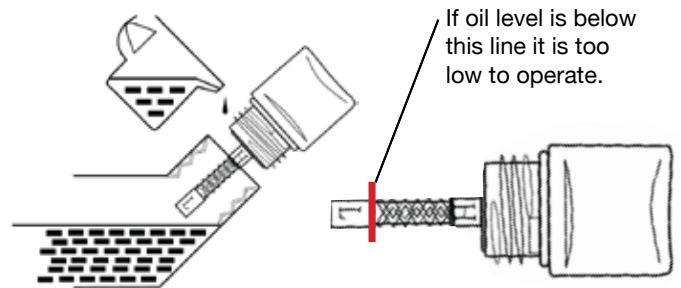

Figure 19 - Checking Oil Level

ADDING ENGINE OIL

1. Always operate or maintain the generator on a flat surface.
2. Stop engine if running.
3. Let engine sit and cool for several minutes (allow crankcase pressure to equalize).
4. Thoroughly clean around the oil fill plug/dipstick.
5. Remove oil fill plug/dipstick and wipe clean.
6. Select the proper engine oil as specified in Figure 17.
7. Using the supplied funnel, slowly add engine oil to the engine. Stop frequently to check the level to avoid overfilling.
8. Continue to add oil until the oil is at the correct level. See Figure 19.
9. Replace the oil fill plug/dipstick.

MAINTENANCE

CHANGING ENGINE OIL

1. Always operate or maintain the generator on a flat surface.
2. Stop the engine.
3. Let engine sit and cool for several minutes (allow crankcase pressure to equalize).
4. Place oil pan (or suitable container) under the oil drain plug (see Figure 20).
5. With a damp rag, thoroughly clean around the oil drain plug.
6. Remove the oil drain plug (see Figure 20). Once removed, place the oil drain plug on a clean surface.

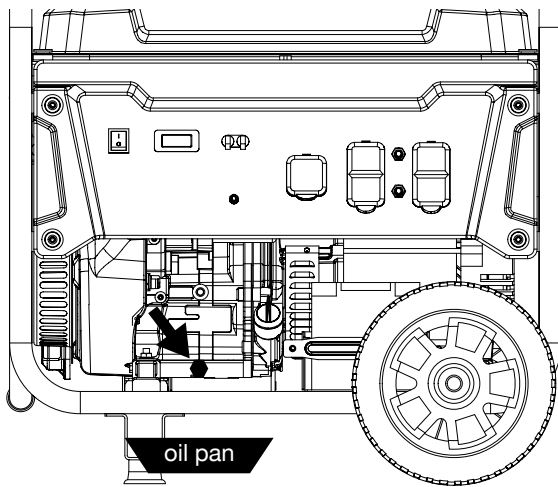

Figure 20 - Oil Drain Plug

7. Allow oil to completely drain.
8. Replace oil drain plug.
9. Fill crankcase with oil following the steps outlined in *Adding Engine Oil* on page 22.

NOTICE

Never dispose of used engine oil by dumping the oil into a sewer, on the ground, or into ground water or waterways. Always be environmentally responsible. Follow the guidelines of the EPA or other governmental agencies for proper disposal of hazardous materials. Consult local authorities or reclamation facility.

AIR FILTER MAINTENANCE

⚠ WARNING



Never use gasoline or other flammable solvents to clean the air filter. Use only household detergent soap to clean the air filter.

Cleaning the Air Filter

The air filter must be cleaned after every 50 hours of use or 3 months (frequency should be increased if generator is operated in a dusty environment).

1. Turn off the generator and let it cool for several minutes if running.
2. Move the generator to a flat, level surface.
3. Unclip the clips on the top and bottom of the air filter cover (Figure 21).

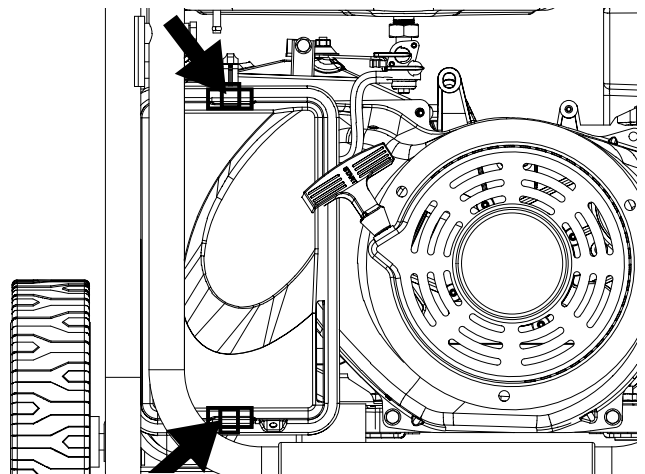

Figure 21 - Unclip air filter

4. Remove the black coarse air filters.
5. Wash the foam air filter elements by submerging the elements in a solution of household detergent soap and warm water. Slowly squeeze the foam to thoroughly clean.

NOTICE

NEVER twist or tear the foam air filter element during cleaning or drying. Only apply slow but firm squeezing action.

6. Rinse in clean water by submerging the air filter elements in fresh water and applying a slow squeezing action

MAINTENANCE

Cleaning the Air Filter - Continued from Page 23

NOTICE

Never dispose of soap cleaning solution used to clean the air filter by dumping the solution into a sewer, on the ground, or into ground water or waterways. Always be environmentally responsible. Follow the guidelines of the EPA or other governmental agencies for proper disposal of hazardous materials. Consult local authorities or reclamation facility.

7. Dispose of used soap cleaning solution properly.
8. Dry the air filter elements by again applying a slow firm squeezing action.
9. Once the air filters are dry, coat the air filters with clean engine oil (see Figure 22).



Figure 22

10. Squeeze the filters to remove any excess oil.
11. Install the filters back into the unit. Make sure the gray (fine) air filter goes in first followed by the black (coarse) air filter on the outside.
12. Install the air filter cover and secure the air filter assembly.

SPARK PLUG MAINTENANCE

The spark plug must be checked and cleaned after every 100 hours of use or 6 months and must be replaced after 300 hours of use or every year.

1. Stop the generator and let it cool for several minutes if running.
2. Move the generator to a flat, level surface.
3. Remove the spark plug boot by firmly pulling the plastic spark plug boot handle directly away from the engine (see Figure 23).

NOTICE

Never apply any side load or move the spark plug laterally when removing the spark plug. Applying a side load or moving the spark plug laterally may crack and damage the spark plug boot.

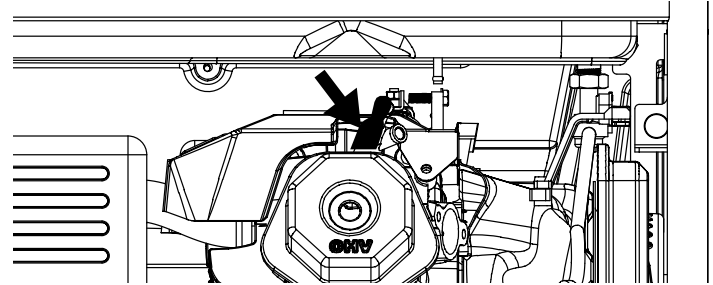
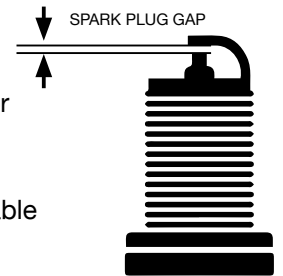

Figure 23 - Remove Spark Plug Boot

4. Clean area around the spark plug.
5. Using the 13/16" spark plug socket wrench provided, remove the spark plug from the cylinder head.
6. Place a clean rag over the opening created by the removal of the spark plug to make sure no dirt can get into the combustion chamber.

Inspect the spark plug for:

- Cracked or chipped insulator
- Excessive wear
- Spark plug gap (the acceptable limit of 0.027–0.032 in. [0.70 – 0.80 mm]).



NOTICE

Use only recommended spark plugs when servicing. The manufacturer is not responsible for engine damage when using spark plugs not recommended by the manufacturer.

7. Install the spark plug by carefully following the steps outlined below:
 - a. Carefully insert the spark plug back into the cylinder head. Hand-thread the spark plug until it bottoms out.
 - b. Using the 13/16" spark plug socket wrench provided, turn the spark plug to ensure it is fully seated.
 - c. Replace the spark plug boot, making sure the boot fully engages the spark plug's tip.

Recommended Spark Plug Replacement:

NGK: (1034) BP7ES (Replacement)

Torch: F7TC (OE Spark Plug)

Westinghouse Part Number: 180526

MAINTENANCE

CHECKING AND ADJUSTING VALVE LASH

⚠ CAUTION



Checking and adjusting valve lash must be done when the engine is cold.

1. Remove the rocker arm cover and carefully remove the gasket. If the gasket is torn or damaged, it must be replaced.
2. Remove the spark plug so the engine can be rotated more easily.
3. Rotate the engine to top dead center (TDC) of the compression stroke. Looking through the spark plug hole, the piston should be at the top.
4. Both the rocker arms should be loose at TDC on the compression stroke. If they are not, rotate the engine 360°.
5. Insert a feeler gauge between the rocker arm and the push rod and check for clearance (see Figure 24). See Table 3 for valve lash specifications.

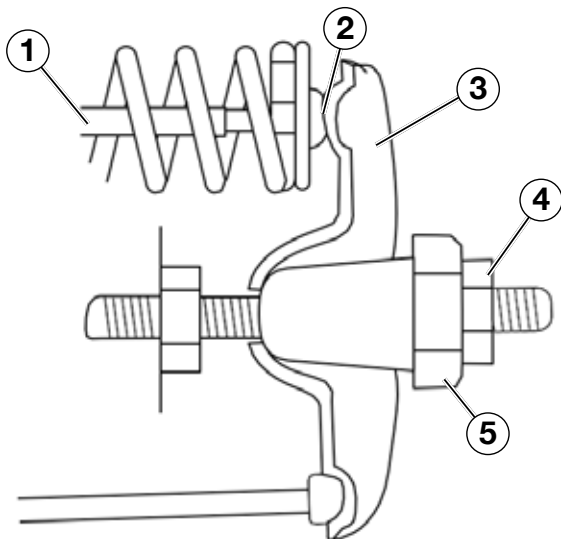

Figure 24

(1) Push Rod, (2) Feeler Gauge Area
(3) Rocker Arm, (4) Jam Nut, (5) Adjusting Nut

(Table 3) Standard Valve Lash

	Intake Valve	Exhaust Valve
Valve Lash	0.0035 ± 0.0043 in (0.09 ± 0.11 mm)	0.0043 ± 0.0051 in (0.11 ± 0.13 mm)
Bolt Torque	8-12N.m	8-12N.m

6. If an adjustment is required, hold the adjusting nut and loosen the jam nut.
7. Turn the adjusting nut to obtain the correct valve lash. When the valve lash is correct, hold the adjusting nut and tighten the jam nut to 106 in-lb (12 N•m).
8. Recheck the valve lash after tightening the jam nut.
9. Perform this procedure for both the intake and exhaust valves.
10. Install the rocker arm cover, gasket and spark plug.

TESTING GFCI OUTLETS

1. Start the generator and allow it to warm up.
2. Press the test button on the GFCI outlet.

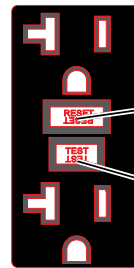

Reset Button

Test Button

3. The reset button should pop out and there will be no power from the outlets. If the reset button does not pop out, the GFCI outlet is not working correctly and must be repaired before the generator can be operated.
4. Press the reset button to restore power to the outlet.

CLEANING THE GENERATOR

It is important to inspect and clean the generator after every use.

Clean All Engine Air Inlet and Outlet Ports – Make sure all engine air inlet and outlet ports are clean of any dirt and debris to ensure the engine does not run hot.

Clean All Engine Cooling Fins – Use a damp rag and a brush to loosen and remove all dirt on or around the engine's cooling fins.

Clean All Alternator Cooling Air Inlets and Exhaust Ports – Make sure the cooling air inlets and exhaust ports of the alternator are free of any debris and obstructions. Use a vacuum cleaner to remove dirt and debris stuck in the cooling air inlets and exhaust ports.

General Cleaning of the Generator – Use a damp rag to clean all remaining surfaces.

MAINTENANCE

STORING GENERATOR

⚠ WARNING



Never store a generator with fuel in the tank indoors or in a poorly ventilated area where the fumes can come in contact with an ignition source such as a: 1) pilot light of a stove, water heater, clothes dryer or any other gas appliance; or 2) spark from an electric appliance.

NOTICE

Gasoline stored for as little as 60 days can go bad, causing gum, varnish and corrosive buildup in fuel lines, fuel passages and the engine. This corrosive buildup restricts the flow of fuel, preventing an engine from starting after a prolonged storage period.

Proper care should be taken to prepare the generator for any storage.

1. Make sure the Engine Switch is switched to **STOP** so the generator does not draw power from battery.
2. Clean the generator as outlined in *Cleaning the Generator*.
3. Drain all gasoline from the fuel tank as best as possible.

4. With the fuel shut off valve open, start the engine and allow the generator to run until all the remaining gasoline in the fuel lines and carburetor is consumed and the engine shuts off.
5. Close the fuel shut off valve.
6. Drain the remaining gas in the carburetor float bowl outlined in *Draining Carburetor Float Bowl* on page 21.
7. Change the oil (see *Changing Engine Oil* on page 23).
8. Remove the spark plug (see *Spark Plug Maintenance* on page 24) and place about 1 tablespoon of oil in the spark plug opening. While placing a clean rag over the spark plug opening, slowly pull there coil handle to allow the engine to turn over several times. This will distribute the oil and protect the cylinder wall from corroding during storage.
9. Replace the spark plug (see *Spark Plug Maintenance* on page 24).
10. Move the generator to a clean, dry place for storage.

TROUBLESHOOTING

⚠ WARNING



Before attempting to service or troubleshoot the generator, the owner or service technician must first read the owner's manual and understand and follow all safety instructions. Failure to follow all instructions may result in conditions that can lead to voiding of the EPA certification or product warranty, serious personal injury, property damage or even death.

PROBLEM	POTENTIAL CAUSE	SOLUTION
Engine is running, but no electrical output	1. Circuit breakers are tripped.	1. Reset the circuit breakers and check for overload condition.
	2. The power cord's plug connector is not fully engaged in the generator's outlet.	2. Verify plug connector is firmly engaged in the generator's outlet. If using the 240V outlet, make sure plug connector is rotated 1/4 turn in the clockwise direction.
	3. Faulty or defective power cord	3. Replace power cord.
	4. Faulty or defective electrical appliance	4. Try connecting a known good appliance to verify the generator is producing electrical power.
	5. GFCI outlet is tripped	5. Press the reset button on the GFCI outlet.
	6. If trying 1-5 above does not solve the problem, the cause might be the generator has a fault.	6. Take the generator to your nearest authorized service dealer.

TROUBLESHOOTING

PROBLEM	POTENTIAL CAUSE	SOLUTION
Engine will not start or remain running while trying to start.	1. Fuel shutoff valve is in the OFF position.	1. Move the fuel shut off valve to the ON position.
	2. Generator is out of gasoline.	2. Add gasoline to the generator.
	3. Fuel flow is obstructed.	3. Inspect and clean fuel delivery passages.
	4. Starting battery may have insufficient charge	4. On electric start models only. Check battery output and charge battery as necessary.
	5. Dirty air filter	5. Check and clean the air filter.
	6. Low oil level shut down switch is preventing the unit from starting.	6. Check oil level and add oil if necessary.
	7. Spark plug boot is not fully engaged with the spark plug tip.	7. Firmly push down on the spark plug boot to ensure the boot is fully engaged
	8. Spark plug is faulty.	8. Remove and check the spark plug. Replace if faulty.
	9. Dirty/plugged spark arrestor	9. Check and clean the spark arrestor.
	10. Stale fuel	10. Drain fuel and replace with fresh fuel.
	11. If trying 1-11 above does not solve the problem, the cause might be the generator has a fault.	11. Take the generator to your nearest authorized service dealer.

Generator suddenly stops running.	1. Generator is out of fuel.	1. Check fuel level. Add fuel if necessary.
	2. The low oil shut down switch has stopped the engine.	2. Check oil level and add oil if necessary.
	3. Too much load	3. Restart the generator and reduce the load.
	4. If trying 1-3 above does not solve the problem, the cause might be a fault in the generator.	4. Take the generator to your nearest authorized service dealer.

Engine runs erratic; does not hold a steady RPM.	1. Dirty air filter	1. Clean the air filter.
	2. Applied loads maybe cycling on and off	2. As applied loads cycle, changes in engine speed may occur; this is a normal condition.
	3. If trying 1-3 above does not solve the problem, the cause might be a fault in the generator	3. Take the generator to your nearest authorized service dealer.

WGen5500 EXPLODED VIEW

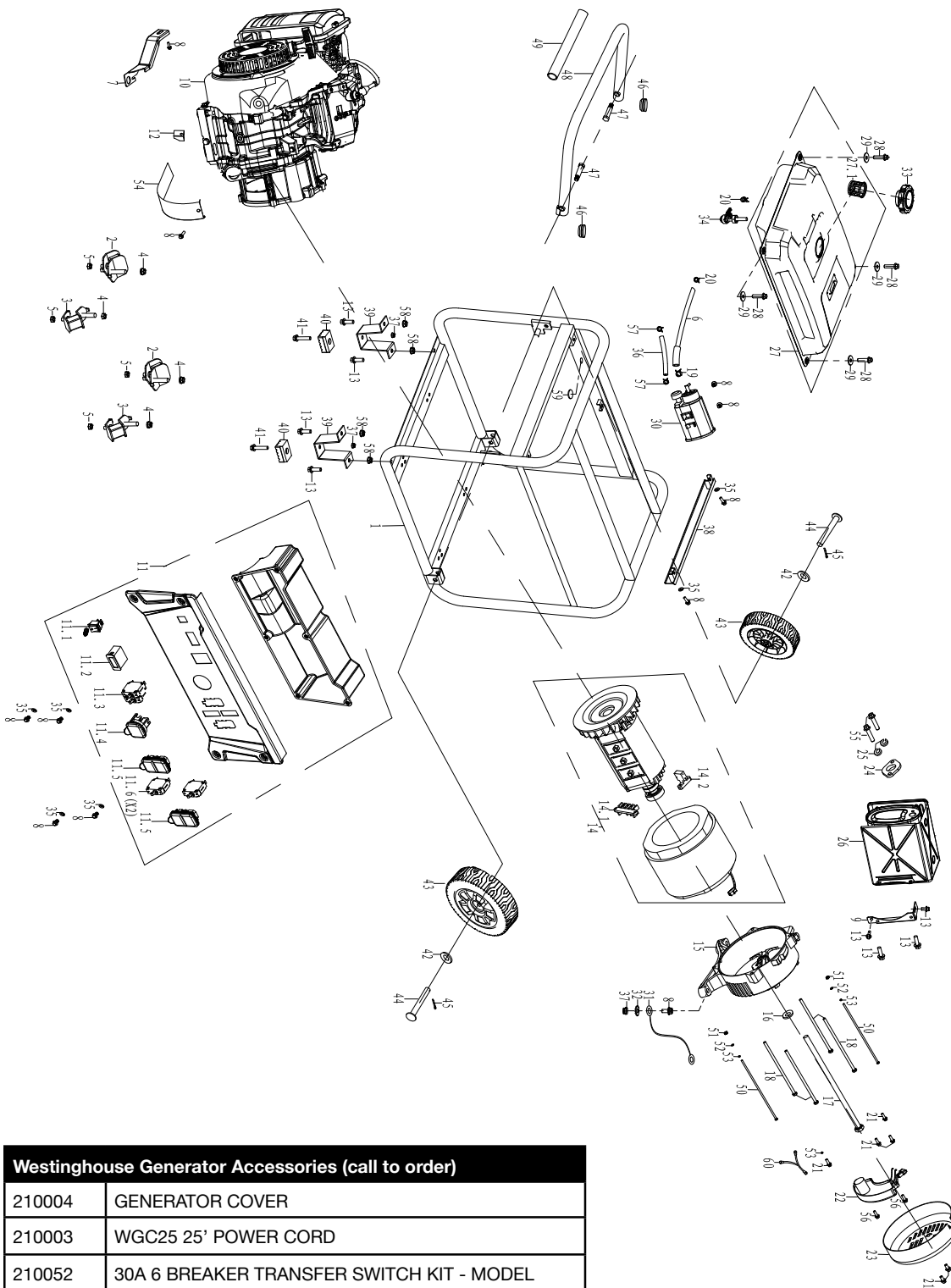

Westinghouse Generator Accessories (call to order)	
210004	GENERATOR COVER
210003	WGC25 25' POWER CORD
210052	30A 6 BREAKER TRANSFER SWITCH KIT - MODEL WHMTS30
210075	25' Cord 30AMP Transfer Switch
210076	50A 6 BREAKER TRANSFER SWITCH KIT - MODEL WHMTS50
210051	25' Cord 50AMP Transfer Switch

WGen5500 EXPLODED VIEW PART NO.

No.	Part.	Description
1	100533	FRAME
2	100552	ISOLATOR B
3	100553	ISOLATOR A
4	100551	NUT M10
5	180524	NUT M8
6	150507	CONNECTING PIPE
7	180563	BRACKET, AIR CLEANER
8	120505	BOLT M6X12
9	110504	MUFFLER BRACKET
10	180564	ENGINE ASSY
11	130501	CONTROL PANEL
11.1	130502	SWITCH ASSEMBLY
11.2	130503	MULTIFUNCTION METER
11.3	130504	CIRCUIT BREAKER 30/2P/23A
11.4	130505	L14-30R
11.5	130506	GFCI RECEPTACLE
11.6	130507	CIRCUIT BREAKER 30/1P/20A
12	180562	DUST PROOF SHEET
13	100516	BOLT M8X16
14	120520	MOTOR ASSEMBLY
14.1	120503	GROUNDING POST COMP
14.2	120502	CARBON BRUSH COMP
15	120504	MOTOR STAND
16	100540	GASKET, ROTOR BOLT Φ10.5xΦ30x4
17	120522	BOLT M10X1.25X255
18	120521	BOLT M6X165
19	100592	CLIP, FUEL LINE Φ9.5
20	140508	CLIP, FUEL LINE Φ7.5
21	120537	BOLT M5X12
22	120523	AUTOMATIC VOLTAGE REGULATOR
23	120519	END COVER, GENERATOR
24	110501	GASKET, EXHAUST PIPE
25	110502	SPRING WASHER
26	110517	MUFFLER COMP
27	150500	FUEL TANK ASSEMBLY
27.1	150506	FUEL FILTER
28	120536	BOLT M6X25

No.	Part.	Description
29	150501	WASHER FUEL TANK
30	150512	CARBON TANK COMP
31	120507	FRAME WIRE
32	120508	BEARING Φ8
33	150505	FUEL TANK CAP COMP
34	150502	FUEL COCK
35	100547	WASHER
36	150510	CONNECTING PIPE
37	120506	NUT M6
38	100530	ROLL BAR
39	100512	SUPPORT, FRAME
40	100515	VIBRATION ISOLATION PAD,SQUARE
41	100518	BOLT M6X25
42	100510	FLAT WASHER Φ13XΦ37X4
43	100506	WHEEL
44	100504	AXLE
45	100508	COTTER PIN
46	100527	PLUG, HANDLE
47	100525	BOLT, HANDLE M10XΦ12.5X53.5
48	100521	HANDLE ASSEMBLY
49	100523	RUBBER, HANDLE
50	120535	BOLT M5X204
51	120510	NUT M5
52	120511	FLAT WASHER Φ5
53	120512	SPRING WASHER Φ5
54	180561	GUARD COVER,CRANKCASE
55	110503	BOLT M8X30
56	120518	BOLT M5X16
57	150516	CLIP, FUEL LINE Φ8
58	100520	NUT M8
59	100529	VIBRATION ISOLATION PAD
60	120516	GROUNDING WIRE

WGen5500 ENGINE VIEW

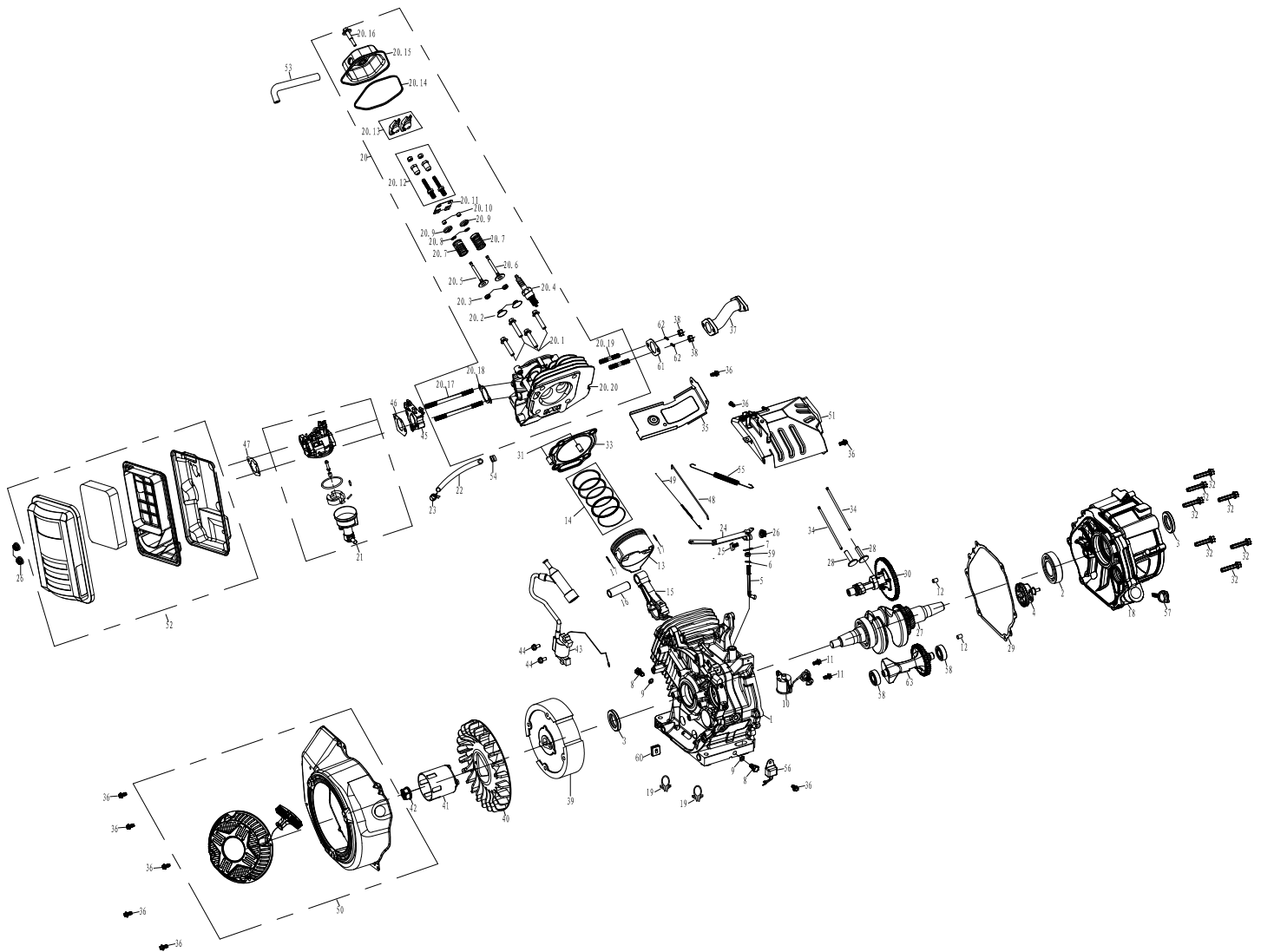

No.	Part.	DESCRIPTION
1	190418	CRANKCASE
2	180536	BALL BEARING
3	180504	OIL SEAL
4	190225	GOVERNOR ASSEMBLY
5	190410	SHAFT, GOVERNOR ARM
6	190409	WASHER, GOVERNOR ARM SHAFT
7	190408	PIN, LOCK
8	180507	BOLT DRAIN PLUG
9	180508	WASHER, DRAIN PLUG
10	180586	SWITCH ASSEMBLY, OIL LEVEL
11	130536	BOLT M6X16

WGen5500 ENGINE VIEW PART NO.

12	180604	DOWEL PIN, CASE COVER
13	190407	PISTON
14	190406	PISTON RING SET
15	190405	ROD ASSEMBLY., CONNECTING
16	190404	PIN, PISTON
17	180791	CLIP, PISTON
18	180534	COVER ASSEMBLY, CRANKCASE
19	170502	CLIP
20	190417	CYLINDER HEAD ASSEMBLY
20.1	180523	BOLT M10X80
20.2	180752	RETURNER, INTAKE VALVE
20.3	180753	OIL SEAL, VALVE
20.4	180526	SPARK PLUG
20.5	180743	VALVE,IN
20.6	180780	VALVE EXHAUST
20.7	190224	SPRING,VALVE
20.8	180744	LOCKING FLAPS
20.9	180755	SEAT, VALVE SPRING,EX
20.10	180756	ROTATOR
20.11	180798	PLATE,PUSH ROD GUIDE
20.12	180636	ADJUSTER ROCKER ARM
20.13	180799	ROCKER ASSY
20.14	180528	HEAD COVER GASKET
20.15	180527	COVER COMP, CYLINDER HEAD
20.16	180529	LOCK BOLT
20.17	140503	BOLT, STUD
20.18	140510	PACKING,INTAKE
20.19	180571	BOLT, STUD
20.20	180514	CYLINDER HEAD
21	140500	CARBURETOR ASSEMBLY
22	140507	FUEL LINE
23	140508	CLIP,FUEL LINE
24	180515	GOVERNOR ARM
25	300075	BOLT,GOVERNOR ARM
26	120506	NUT M6
27	190416	CRANKSHAFT ASSEMBLY
28	190402	LIFTER,VALVE
29	180574	PACKING, CASE COVER
30	190415	CAMSHAFT ASSEMBLY
31	180742	PIN DOWEL
32	180808	BOLT M8X40
33	190414	GASKET, CYLINDER HEAD

34	180810	ROD, PUSH
35	180520	SHROUD
36	120505	BOLT M6X12
37	180521	EXHAUST PIPE
38	180524	NUT M8
39	180573	FLYWHEEL ASSEMBLY
40	180502	FAN, RECOIL STARTER
41	180501	PULLEY, STARTER
42	180500	CRANKSHAFT NUT
43	180505	IGNITION COIL ASSY
44	100518	BOLT M6X25
45	140502	INSULATOR, CARBURETOR
46	140509	PACKING, CARBURETOR
47	140505	SPACER, CARBURETOR
48	180516	ROD, GOVERNOR
49	180517	SPRING, THROTTLE RETURN
50	170500	RECOIL STARTER ASSEMBLY
51	180519	SHROUD ASSY, UPPER
52	160500	AIR CLEANER ASSEMBLY
53	180533	TUBE, BREATHER
54	140506	RUBBER, FUEL
55	180518	SPRING, GOVERNOR
56	180509	AMPLIFIER
57	180531	DIPSTICK
58	190413	BALL BEARING
59	190412	SEAL, GOVERNOR ARM SHAFT
60	180510	RUBBER STARTER ASSY
61	180522	EXHAUST GASKET
62	110502	SPRING WASHER
63	190401	BALANCING SHAFT
0	230523	1.1L OIL BOTTLE
0	160037	AIR FILTER ELEMENT

WGen5500 SCHEMATIC

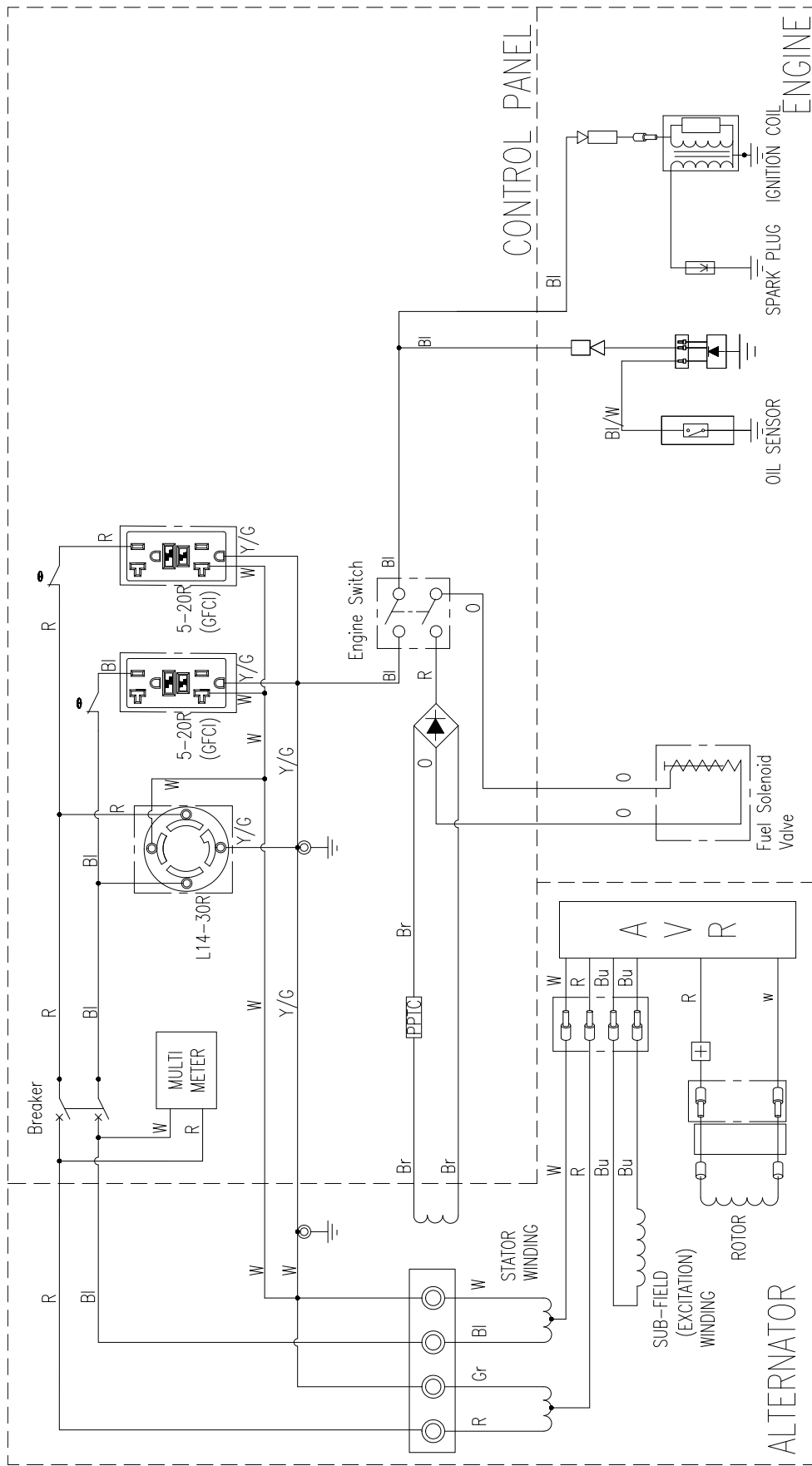

WGen5500 Specifications

Gasoline Running Watts	5500
Gasoline Peak Watts	6850
Running Amps	23 amps
Peak Amps	28 amps
AC Voltage	120/240 Volts
AC Frequency	60 Hz
Engine Horse Power (HP)	13 HP
Total Harmonic Distortion (THD)	<23%
Automatic Voltage Regulator (AVR)	Yes
Starting System	Recoil
Battery	No
Push Button Start	No
Mobile App Compatible	No
Engine Displacement	420cc
Engine Brand	Westinghouse
Engine Type	OHV 4 Stroke
Engine RPM	3600
Operational Volume (dBA)	72 dBA
Spark Plug (included)	Torch F7TC
Carburetor Kit Required to Operate at Altitude	Yes
Altitude Carburetor Kit Number (sold separate)	140545
Auto Idle Control	No
Built-in Inverter	No
Engine Lubrication	Splash
Recommended Oil	SAE 10W30
Oil Bottle Size (included)	1.1 qt. (37.2 oz.)
Oil Capacity (Quarts/Ounces)	1.1 qt. (37.2 oz.)
Low Oil Shutdown	Automatic
Fuel Type	Unleaded Gasoline, 10% Ethanol or less
Fuel Shut Off	Manual
Fuel Tank Material	Steel
Fuel Tank Capacity (Gallons/Liters)	6.6 gal. (25 L)
Run Time at %25 Load (hrs.)	20 hrs.
Run Time at %50 Load (hrs.)	15 hrs.
Gasoline Fuel Gauge	Yes
Choke type	Manual

Choke Location	Above Air Filter
AC Outlets	(1) 120/240V 30A (L14-30R), (2) Duplex 120V 20A GFCI (5-20R)
Ground	Neutral Bonded
Covered Outlets	Yes
Transfer Switch Ready	Yes
Westinghouse Portable Transfer Switch Ready (ST Switch)	No
GFCI Outlets	Yes
VFT Data Center (volts, frequency, lifetime hours)	Yes
RV Ready Outlet	No
Overload Protection (circuit breaker)	Yes
Handle Style	Single Handle with Foam Grip
Wheel Kit Included	Yes
Wheel Size	10 in. Diameter, 2.5 in. Wide
Wheel Type	Polyurethane
Frame Thickness in. (mm)	1.25 in. (32 mm)
Emissions	EPA, CARB
Canada CSA Compliant	Yes
Muffler	Pulse-Flo™
Spark Arrestor	Yes
Residential Warranty	3 Years or 1000 hrs
Commercial Warranty	6 Months or 1000 hrs
Assembled Length in. (mm)	26.75 in. (680 mm)
Assembled Width in. (mm)	26.5 in. (673 mm)
Assembled Height in. (mm)	26.125 in. (664 mm)
Extended Length in. (mm)	40.7 in. (1033.8 mm)
Carton Length in. (mm)	31.25 in. (794 mm)
Carton Width in. (mm)	21.5 in. (546 mm)
Carton Height in. (mm)	23.5 in. (596 mm)
Dry Unit Weight lb. (kg)	174 lb. (88 kg)
Shipping Weight lb. (kg)	182 lb. (91.6 kg)
UPC	855464003971
GTIN	00855464003971



WestinghousePortablePower.com

Service Hotline: (855) 944-3571

**777 Manor Park Drive
Columbus, OH 43228**

™ & © 2016 Westinghouse Electric Corporation
© 2016 MWE Investments, LLC. All Rights Reserved.

Version 07.23.18KD