



**SERVICE MANUAL  
PARTS LIST**

**SHAMPOO POLISHER**

***MODELS:***

**P-620 A**

**P-800**

**P-820 A**

**SERVICE**

KOBLENZ ELECTRICA S.A. DE C.V.  
E-mail: [thorne\\_scsm@koblenz-electric.com](mailto:thorne_scsm@koblenz-electric.com)

NOVEMBER-06  
LP-P620A-200611

## INDEX

	PAGE
I.- FINAL TEST FOR PRODUCT SAFETY	3
II.- REPLACEMENT PROCEDURES	3
III.- TROUBLE SHOOTING CHART	6
IV.- ELECTRICAL RATING	7
V.- WIRING DIAGRAM	7
VI.- SCHEMATIC ,EXTERNAL PARTS	8
VII.- EXTERNAL MACHINE PARTS LIST	9
VIII.- SCHEMATIC ,INTERNAL PARTS	10
IX.- INTERNAL MACHINE PARTS	11

## I. - FINAL TEST FOR PRODUCT SAFETY

AT THE COMPLETION OF ANY REPAIR THE PRODUCT SHOULD BE ELECTRICALLY TESTED FOR RUNNING AND ELECTRIC STRENGTH AS FOLLOWS

### ELECTRIC TEST

- A). - Set hi-pot meter at 1500 V
- B). -Product Switch to on position.
- C). -Touch one probes of tester to on blade of power cord plug and touch other probe to handle tube. There should be no breakdown.

### RUNNING

#### RUN THE MACHINE WITHOUT BRUSHES ( FREE RUNNING ) AND CHECK :

- A) . -There should be no unusual noise or vibration.
- B) . -The carbon brushes spark should be small and uniform
- C) . – The current shall be no more than 1.5 A
- D) .- Run the machine with scrubbing brushes on the floor ,the current shall be 3.0 A

## II. - REPLACEMENT PROCEDURES ASSEMBLY

### 1.TO REPLACED A FIELD ( 41 ) OR ARMATURE ( 63 )

- 1.1.-Disconnected elbow hose connector ( 41 ) from tray assembly ( 95 )
- 1.2.- Remove cover ( 31 ) by removing four cover screws ( 93 )
- 1.3.-Pull open the connector on the motor cable ( 19 )
- 1.4.- Remove the connector support ( 87 ) with the connector block ( 75 )
- 1.5.-Remove gear cover plate screws ( 61 ) from both sides along with cover plates and gaskets ( 84-85-86 )
- 1.6.-Remove the four motor covers screws ( 61-99 ) and the motor cover ( 60 )
- 1.7.-Remove the bearing clamp screws ( 68 ) from both sides along with the bearing clamps ( 69 )
- 1.8.- Remove the carbon brush holder assembly ( 62 )
- 1.9.-Remove the field support screws ( 64 ) and field supports ( 65-66 )
- 1.10.-To replace the field , the connector block ( 75 ) must be removed , push the retaining tab of each terminal with a pin and release it by pulling it pulling it out .
- 1.11.-The field ( 67 ) and armature ( 63 ) may now be lifted out replacement .

### 2.- TO REASSEMBLE

- 2.1.-Position the armature in the field so that the armature commutator is on the same side as the field leads
- 2.2.-Position an armature bearing package ( 70-71-72-74 ) on each end of the armature shaft so that the rectangular projection on the seal is facing the armature winding and is between the bearing and armature .
- 2.3.-Position the armature ( 63 ) and the field ( 67 ) in the motor frame ( 88 ) making sure the leads side of the field ( 67 ) are placed close to the bottom windows in the motor frame ( 88 ) witch are next to the carbon brush holder ( 62 ) .
- 2.4.-The armature bearing and seals on the armature ( 63 ) ate positioned in their respective places in the motor frame ( 88 ) making sure the two straight sides on the boss of the bearings are in the vertical position.
- 2.5.-Hold the field position replacing the fields supports ( 65,66 ) and screws ( 64 )
- 2.6.-Replace the carbon brush holder ( 62 ) and carbon brushes .
- 2.7.-Make sure that armature thrust plates and the armature thrust balls are in position on the ends of the armature shaft.
- 2.8.- Replace armature bearing clamps ( 69 ) on top of the armature bearing ,with screws ( 68 )
- 2.9.-Adjust endplay by adding thin plates until there is 0.005"-0.010" clearance between the armatures thrust plate on the fan end of the unit .measured by a feeler gage.
- 2.10.-Replace the cover plates ,gaskets and screws ( 84-85-86 ) and ( 61 ) .
- 2.11.-place the block ( 75i), n the detent connector ( 75 ) , and push close the connector on motor cable ( 24 ) .
- 2.12.- Place the unit into the cover ( 31 ) and secure with the four cover screws ( 93 ) .
- 2.13.-Reconnect the elbow hose connector ( 41 ) into the tray ( 95 )

### **3 .- TO REPLACE GEAR ( 77 OR 78 ) OR A SPINDLE ( 79 )**

- 3.1.- Remove the four cover screws ( 93 ) separate the base plate ( 92 ) and motor assembly from cover ( 31 )
- 3.2.-Pull open the connector on motor cable ( 19 )
- 3.3.- Remove the motor cable bushing with the motor cable ( 19 )
- 3.4.-Remove the connector support ( 87 ) with connector block ( 75 ) ,now the motor assembly may be worked on more easily.
- 3.5.-Remove the spindle brush drive pin ( 96D ) by driving it out with a cylindrical punch of suitable diameter and remove the pin insulator ( 96 E )
- 3.6.-Remove the spindle cap insulator ( 96A ) pressing the tab ( 96 C ) and pulling the cap out .
- 3.7.- Remove the caps from the tree screw insulators ( 94 ) by prying them of with a screw driver placed opposite the strap tab on the part and remove the three motor frame holding screws ( 93 )
- 3.8.-Remove the base plate ( 92 ) from the motor assembly .
- 3.9.-Remove frame insulators ( 83 ) ,spindle retainers ( 82 ) and washers ( 81 )
- 3.10.-Remove the gear case cobber plate screws ( 61 ) ,the cover plates and the cover plate gaskets ( 84-85-86 ) and the motor cover ( 60 ) ,this provides access to gearboxes.
- 3.11.-The gears ( 77 or 78 ) or spindle ( 79 ) may now be removed by lightly tapping the bottom of the spindle.
- 3.12.-Remove the spindle nuts ( 76 ) the gears ( 77 or 78 ) and their keys ( 80 )
- 3.13.-The gearboxes should be cleaned of all foreign material and old grease .
- 3.14.-Inpesct the condition of the armature shaft ( 63 ) and gears ( 77-78 ) ,if they are damaged ,replace them .
- 3.15.-The gears may be replaced by aligning the slot in the gear with the slot in the new or old spindle and reinserting the key ( 80 ) making sure the gear shoulder is placed below in contact with the motor frame and the gear ( 77 or 78 ) is leaning on the nut ( 76 ) .
- 3.16.-Position the gear ( 77 or 78 ) assembled to the spindle ( 79 ) in the motor frame ( 88 ) and replaces the washers ( 81 ) spindle retainer ( 82 ) and frame insulators ( 83 ) , the axial play of the spindle should be less than 0.10" .
- 3.17.-The gear boxes should be regressed with the grease provided in the bag together with the gears ,making sure all the grease is used ,the most of it applied in the contact zone of the gears
- 3.18.-Reassembly cover plates ,cover plate gaskets (84-85-86),motor cover ( 60 ) and screws ( 61-92) on reverse order used for disassembly .
- 3.19.-Replace the connector support ( 87 ) with the connector block ( 75 ) .
- 3.20.-Replace the motor cable bushing and push close the connector ion motor cable ( 19 )
- 3.21.-Reassemble the motor assembly to the base plate ( 83 ) in a reverse order used for disassembly ,making sure the frame spacers ( 83 ) and motor supports ( 90 ) are well positioned.

### **4.-TO REPLACE THE CARBON BRUSHER ( 62 )**

- 4.1.- Follow steps 1.1,1.2,1.6,1.8
- 4.2.- Replace the carbon brushes and reassemble .

### **5.-TO REPLACE THE MOTOR CABLE ( 19 )**

- 5.1.-Remove four covers screws ( 93 ) and remove base plate ( 92 ) from the cover ( 31 )
- 5.2.-Pull open the connector on motor cable ( 19 ) .
- 5.3.-Remove the motor cable bushing.
- 5.4.-Remove the switch box retaining screw ( 6 )
- 5.5.-Remove the switch box ( 5 ) from tube ( 2 ) .
- 5.6.-Remove the switch cover screws ( 4 ) and open the cover ( 9 )
- 5.7.-Disconnect the motor cable ( 19 ) from the switch ( 8 ) inserting a round needle of 1.5 mm diameter into the switch hole of each wire and pulling out the wire .
- 5.8.-Connect the new motor cable leads to the switch.
- 5.9.-Place the switch on the box replace the cover ( 9 ),the screws ( 4 ) and the knob ( 11 )
- 5.10.-Reassemble the switch boxes in the handle and secures it with the switch box retaining screw ( 6 ) .

### **6 .-TO REPLACE A LINE CORD ( 18 )**

- 6.1.- Follow steps 5.4,5.5 y 5.6.
- 6.2.-Disconnected the line cord ( 18 ) from the switch ( 8 ) inserting a round pointed needle of 1.5 mm diameter into the switch hole of each wire and pulling out the wire .
- 6.3.-after replacement is an accomplished ,the line cord ( 18 ) must be reassemble in exactly the same manner as it was prior to disassembly.

6.4.- Follow steps 5.9 and 5.10.

## **7 .-TO REPLACE THE SWITCH ( 8 ) .**

7.1.-Remove the switch box retaining screw ( 6 )

7.2.-Remove switch box ( 5 ) from handle tube ( 2 ) .

7.3.-Remove the switch cover screws ( 4 ) and open the cover ( 9 )

7.4.-The switch ( 8 ) is held in position by the switch box cover and can now be removed .

7.5.-Disconnctd switch ( 8 ) from line cord ( 18 ) and the motor ( 19 ) inserting a round pointed needle of 1.5 mm diameter into the switch hole of each wire and pilling out the wire ,replace it with a new switch making sure that wires are replaced on the same position as they were prior to removal .

7.6.-Place the switch on the box and replace the cover ( 9 ) ,the screws ( 4 ) and the knob ( 11 ) .

7.7.-Reassemble the switch on the box in the handle and secure with box retaining screw ( 6 ) .

## **8 .-TO REPLACE A FAULTY BRUSH SPINDLE INSULATOR ( 96 A )**

8.1.-Remove the spindle drive pin ( 96 D ) by driving it out with a cylindrical punch of suitable diameter and remove the pin insulator ( 96 E )

8.2.-Remove the spindle cap insulator ( 96 A ) by pressing the tab ( 96 C ) and pulling the cap insulator out .

8.3.-Assemble the spindle insulator ( 96 A ) makes certain that the holes in the spindle ( 79 ) and the spindle insulator ( 96 A ) is aligned.

8.4.-Reassemble the brush drive pin so that equal it is exposed on either side of the spindle insulator ( 96 E ) .

## **9 .-TO REPLACE A MOTOR FRAME ( 88 OR A BASE PLATE ) ( 92 )**

9.1.-Follow steps 1.1,1.2,1.3,3.2,3.2.3,3.5,3.6,3.7 and separate the base plate from the motor frame.

9.2.-Remove the screws ( 98 ) ,the washers ( 97 ) and the tray ( 95 ) .

9.3.-Base plate may now be replaced.

9.4.-To replace the motor frame ,follow steps 3.4,3.9,3.10,3.11.

9.5.-Remove four screws ( 64 ) and field supports ( 65-66 ) .

9.6.-Disconnect field wires from brush holder support ( 62 ) and remove it,

9.7.-Remove screws ( 68 ) and bearing clamps ( 69 ) .

9.8.-Remove push plates ( 73-74 ) and thrust balls ( 72 ) .

9.9.-Remove the field ( 67 ) and armature assembly ( 63 ) from the motor frame.

9.10.-The motor frame may now be replaced.

9.11.-For assembly of base plate ( 92 ) or motor frame ( 88 ) the steps are followed in reverse order.

### III.- TROUBLE SHOOTING CHART

PROBLEM	POSSIBLE CAUSE	SOLUTION
1) Shampooed / Polisher does not run	A) Defective Switch. B) Defective power cord. C) Defective internal wiring. D) Motor failure. E) Worn carbon brushes	Replace switch. Replace power cord. Check wire connection at switch, check motor Cord check armature and held and replace Armature and/ or field. Replace carbon brushes.
2) Excessive arcing	A) Dirt build up in motor B) Bad armature C) Worn carbon brushes	Blow with clean air Replace armature Replace carbon brushes.
3) Cleaning Brush does not run	A) Broken or missing drive pin. B) Gear failure.	Replace drive pin. Replace gear
4) Handle and yoke assembly does remain in " up " position	A) Worn or broken yoke spring	Replace yoke spring
5) Cleaning brush does not lock on spindle cap	A) Defective spindle cap or brush retainer	Replace spindle cap or retainer
6) Cleaning brush does not lock on coupling.	A) Defective coupling	Replace coupling.

**WHEN ORDERING, DO NOT FORGET TO SPECIFY:**

- ✓ **PART NUMBER**
- ✓ **DESCRIPTION**
- ✓ **MODEL NUMBER**

**NOTE: Drawing numbers are for identification purposes only.**

#### IV. - ELECTRICAL RATING

V~  
120

A  
4.2

Hz  
50/60

#### V. - WIRING DIAGRAM

MODEL P-620

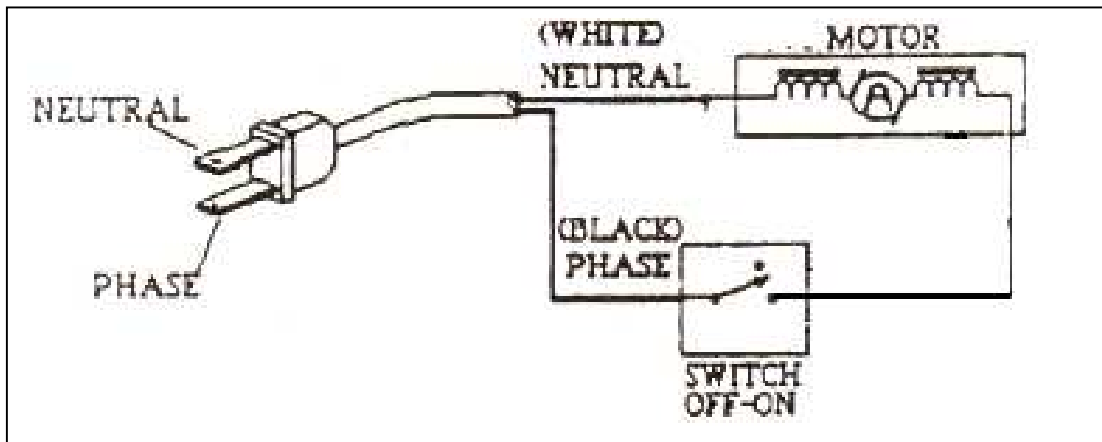

MODEL P-800 , P-820

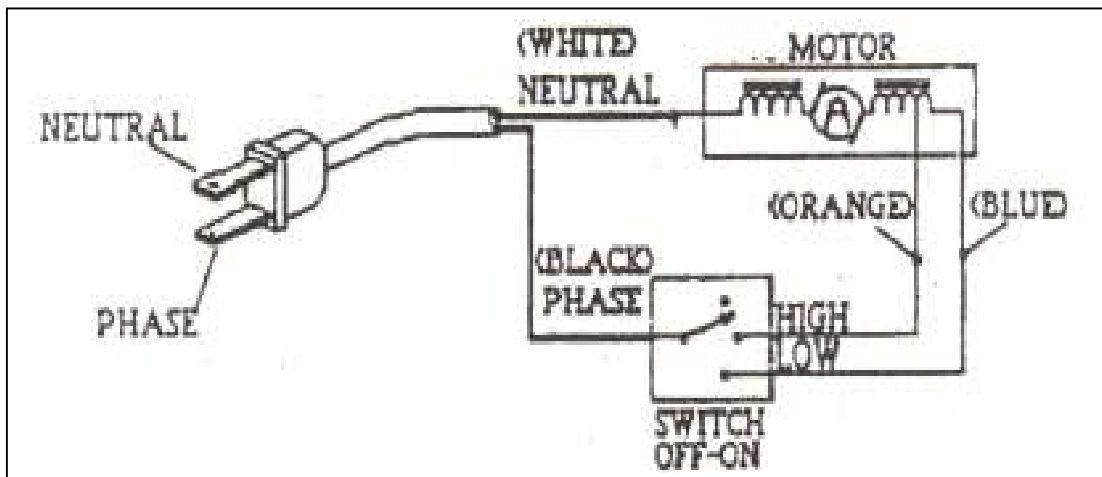

VI. - SCHEMATIC. EXTERNAL MACHINE PARTS

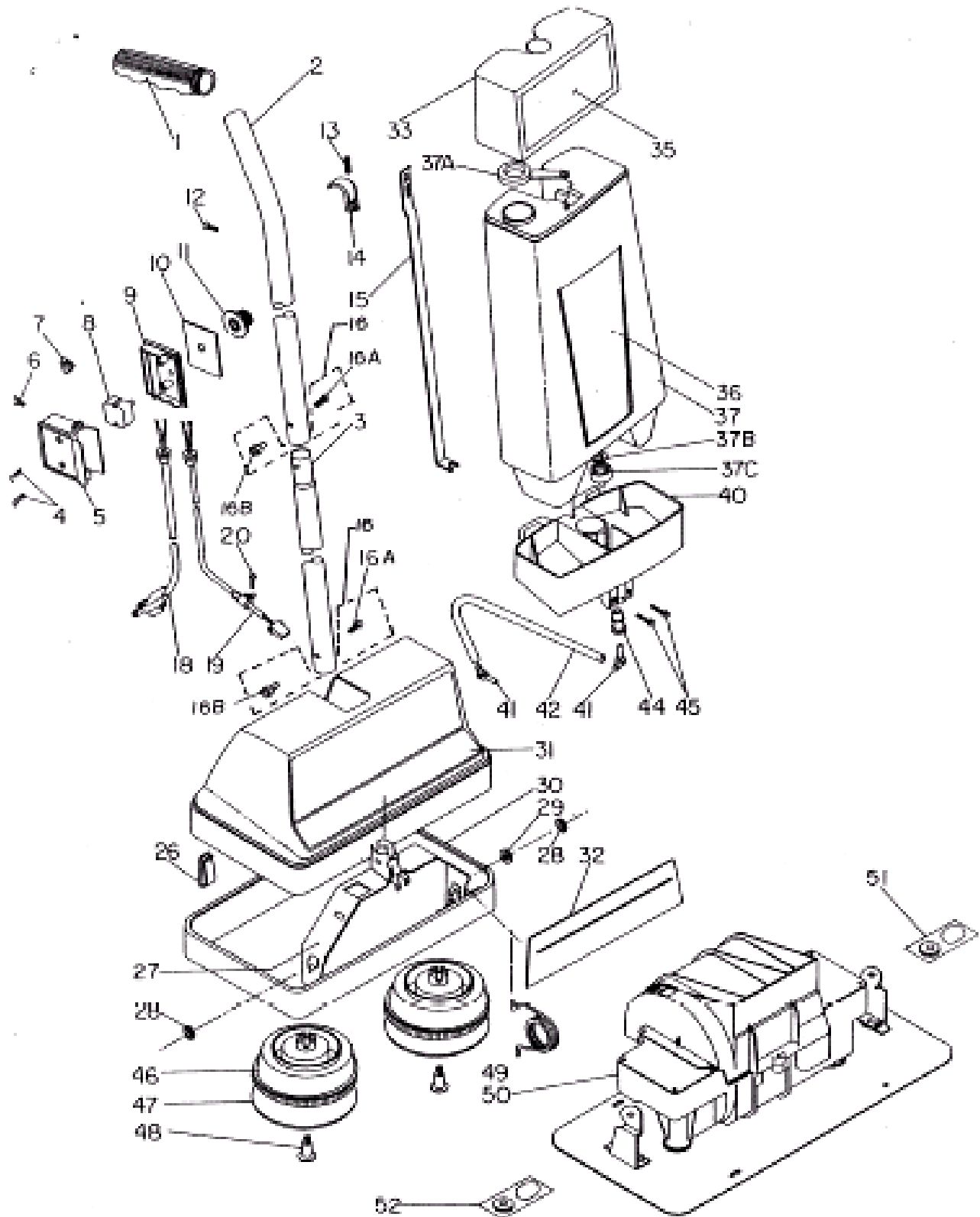



## VII.- EXTERNAL MACHINE PARTS LIST

No.	PART. No.	DESCRIPTION	P-620-A	P-800	P-820-A
1	13-0947-5	HANDLE GRIP	1	1	2
2	05-3676-3	UPPER HANDLE TUBE			1
2	05-4257-1	UPPER HANDLE TUBE	1		1
2	06-3674-8	UPPER HANDLE TUBE		1	
3	05-4256-3	LOWER HANDLE TUBE	1		
3	05-3684-7	LOWER HANDLE TUBE		1	
3	05-3686-2	LOWER HANDLE TUBE BLUE			1
4	01-0536-1	SELF-TAPPING SCREW #6-20	2	2	2
5	13-0950-9	BLACK SWITCH BOX	1	1	1
6	01-0154-3	SELF-TAPPING SCREW #6X5/16	1	1	2
7	10-0042-1	P. NOZZLE WIRE CONNECTOR	1	1	1
8	11-0082-5	2-SPEED SWITCH	1	1	1
9	13-0951-7	BLACK SWITCH BOX COVER	1	1	1
10	17-4131-3	BOX LABEL 1 SPEED	1		
10	17-2085-3	BOX LABEL 2 SPEED		1	
10	17-4090-1	BOX LABEL 2 SPEED			1
11	13-0952-5	BLACK SWITCH KNOB	1	1	1
12	01-0273-1	SCREW 6 x 5/8	1	1	1
13	24-0091-9	TRIGGER SPRING		1	1
14	13-1062-2	DISPENSER TRIGGER		1	1
15	05-1721-9	DISPENSER ROD		1	1
16	45-0330-6	HANDLE SCREW & NUT PACKAGE	2	2	2
16-A	01-0747-4	SCREW #10-32	2	2	2
16-B	02-0067-5	USE 02-0141-8	2	2	2
18	10-0099-1	POWER CORD, BLACK			
19	28-0403-7	MOTOR CABLE ASSEMBLY 1 SPEED	1		
19	28-0300-5	3-SPEED CABLE ASSEMBLY		1	1
20	01-0063-6	SCREW 6 X 1/2	1	1	1
26	05-2692-1	CLIP	1	1	1
27	46-2861-6	YOKE ASSEMBLY			1
27	46-2862-4	YOKE ASSEMBLY	1		
27	46-1180-2	YOKE ASSEMBLY		1	
28	04-0444-2	YOKE RETAINING	2	2	2
29	13-0715-6	SPACING WASHER	1	1	1
30	12-0457-7	FURNITURE GUARD	1	1	1
31	13-2586-9	COVER BLUE	1		1
31	13-0578-8	COVER BLUE		1	
32	17-4088-5	HEAD LEVEL	1		
32	17-2003-6	HEAD LEVEL		1	
33	13-0865-9	CONTAINER TOP		1	
35	17-2004-4	CONTAINER TOP LABEL		1	
36	17-4089-3	TANK LABEL			1
37	45-0533-5	120 OZ. TANK ASSEMBLY BLUE			1
37	45-0015-3	TANK 120 OZ		1	
37-A	13-0064-9	TANK CAP			
37-B	04-0136-4	WASHER VALVE SPRING CUP			
37-C	13-0068-0	VALVE CAP			
40	13-2588-5	CONTAINER BASE BLUE			1
40	13-0554-9	CONTAINER BASE WHITE		1	
41	13-0065-6	ELBOW HOSE CONNECTOR			2
42	13-0076-3	HOSE		.24 M	.24 M
44	12-0694-5	CONTAINER BASE SEAL		1	1
45	01-1093-2	SELF-TAPPING SCREW		2	2
46	45-0092-2	SHAMPOO BRUSH		2	2
46	45-0093-0	SCRUB BRUSH	2		
47	37-0094-5	TAN POLISHING PAD	2	2	2
47	37-0095-2	LAN WOOL HIGH LUSTER PAD	2	2	2
48	13-0141-5	PAD RETAINER	2	2	2
48	45-0268-8	PAD RETAINER	1	1	1
49	24-0244-4	YOKE SPRING			
50	46-1729-6	MOTORS ASSEMBLY 1 SPEED	1		
50	46-1570-4	MOTOR ASSEMBLY 2 SPEED		1	1
51	46-1717-1	REPLACEMENT GEAR AND GREASE	1	1	1
52	46-1718-9	REPLACEMENT GEAR AND GREASE	1	1	1
53	20-0529-6	ALL PURPOSE NEUTRAL CLEANER		1	1
53	20-0586-6	ALL PURPOSE HEAVY DUTY CLEANER		1	1
53	20-0587-4	CARPET SHAMPOO		1	1

# VIII. – SCHEMATIC , INTERNAL MACHINE PARTS

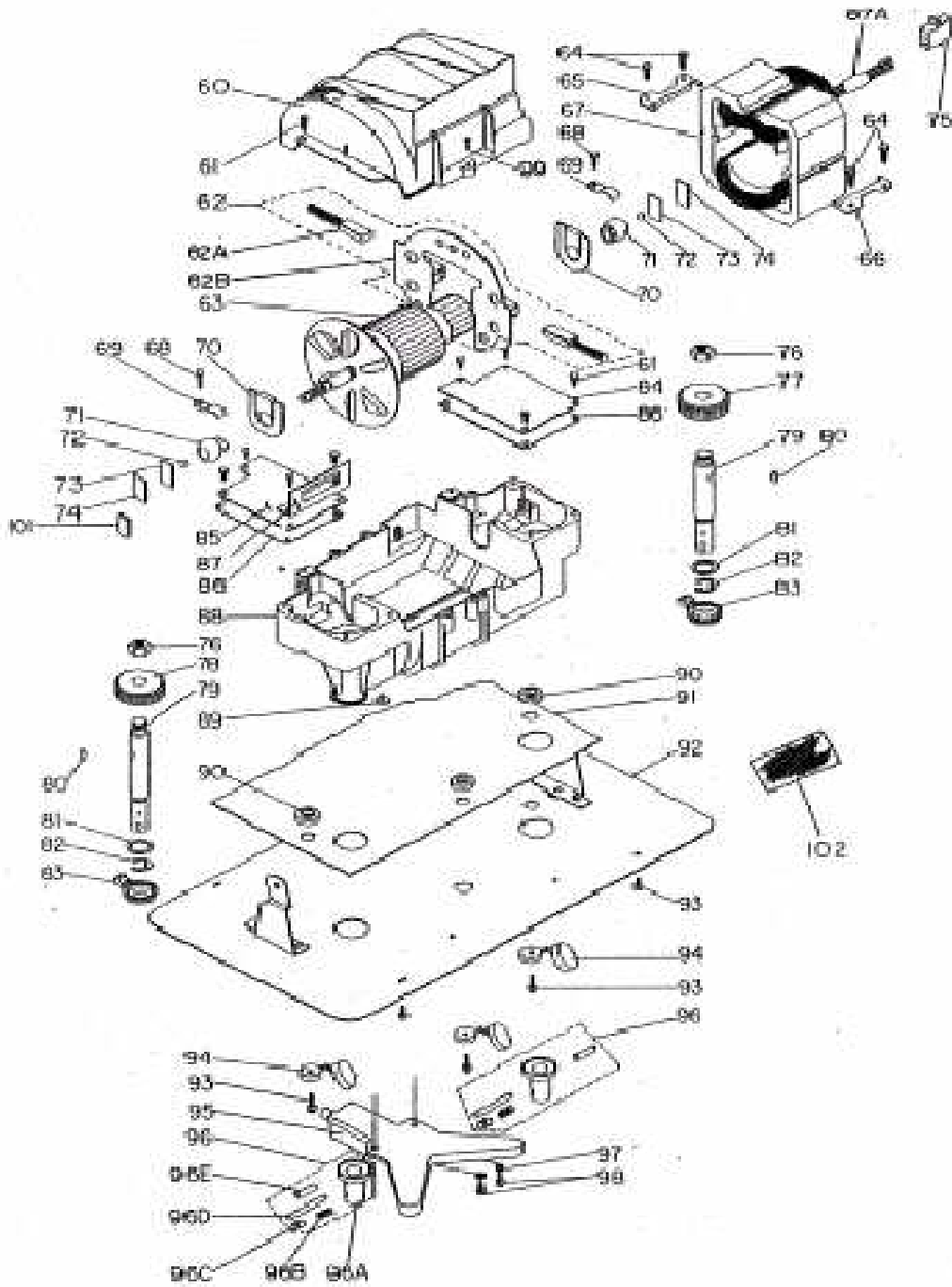

**IX .- INTERNAL MACHINE PARTS LIST**

No.	PART. No.	DESCRIPTION	P-620	P-800	P-820-A
60	13-1418-6	MOTOR COVER	1	1	1
61	01-1483-5	SELF-TAPPING SCREW #6 X 3/8	10	10	10
62	28-0324-5	BRUSH HOLDER ASS	1	1	1
62-A	46-0104-3	CARBON BRUSH & SPRING	1	1	1
62-B	46-0590-3	BRUSH HOLDER	1	1	1
63	28-0263-5	ARMATURE	1	1	1
64	01-1489-2	SCREW #8 X 1 1/2	4	4	4
65	05-2862-0	FIELD SUPPORT	1	1	1
66	05-2864-6	FRONT FIELD SUPPORT	1	1	1
67	28-0308-8	2-SPEED FIELD		1	1
67	28-0585-1	FIELD 1 SPEED	1		
67-A	08-1458-2	FIELD SLEEVE	1	1	1
68	01-1490-0	SCREW	2	2	2
69	05-0607-1	BEARING CLAMP	2	2	2
70	12-0133-4	ARMATURE BEARING SEAL	2	2	2
71	26-0026-0	ARMATURE BEARING	2	2	2
72	26-0001-3	BALL ARM SHAFT/R - 30465P2	2	2	2
73	25-0059-3	THICK PUSH PLATE	2	2	2
74	25-0060-1	THIN PUSH PLATE	4	4	4
75	10-0051-2	CONNECTOR BLOCK 3 SPEED	1		
75	10-0054-6	CONNECTOR BLOCK 3 SPED		1	1
76	02-0016-2	SPINDLE NUT	2	2	2
77	42-0011-9	RIGHT BRONZE GEAR	1	1	1
78	42-0012-7	LEFT BRONZE GEAR	1	1	1
79	25-1024-6	SPINDLE	2	2	2
80	25-0988-3	GEAR SPINDLE KEY	2	2	2
81	04-0018-4	WASHER .500 X .685	4	4	4
82	04-0238-8	SPINDLE RETAINER	2	2	2
83	13-1956-5	FRAME INSULATOR	2	2	2
84	23-0462-4	GEAR CASE COVER	1	1	1
85	23-0461-6	GEAR CASE COVER	1	1	1
86	37-0133-1	GASKET GEAR COVER	2	2	2
87	05-2718-4	CONNECTOR SUPPORT		1	1
87	05-2717-6	CONNECTOR SUPPORT	1		
88	23-0330-3	MOTOR FRAME ASSEMBLY	1	1	1
89	13-0059-9	FRAME SPACER	1	1	1
90	13-1040-8	MOTOR SUPPORT	3	3	3
91	13-0758-6	BASE INSULATOR	1	1	1
92	23-0499-6	BASE PLATE ASSEMBLY	1	1	1
93	01-1489-2	SCREW #8 X 1 1/2	7	7	7
94	13-0551-5	SCREW INSULATOR	3	3	3
95	13-0216-5	TRAY		1	1
96	46-1610-8	SPINDLE CAP INSULATOR PKG.	2	2	2
96-A	13-1038-2	SPINDLE CAP	2	2	2
96-B	24-0225-3	BRUSH LOCK SPRING	2	2	2
96-C	13-1039-0	LATCH NIB	2	2	2
96-D	25-0415-7	SPIRAL PIN 5/32 X 1	2	2	2
96-E	13-1135-6	BOLT INSULATOR	2	2	2
97	04-0002-8	WASHER .156 X .375		2	2
98	01-0154-3	SELF-TAPPING SCREW #6X5/16		2	2
99	01-0066-9	SCREW 6 X 7/8	1	1	1
101	25-1063-4	THIN THRUST PLATE	1	1	1

FACTORY AUTHORIZED SERVICE

Thorne Electric Company

610 Lanark Suite 205

San Antonio TX,78218

Tel (210) 590-1226

Fax (210) 590-1258

1-800-548-5741

FACTORY

Koblenz Electrica ,S.A. de C.V.

Av. . Ciencia No 28 Cuautitlán Izcalli

Edo. de México ,C.P. 54730

Tel : 5864-0300

Web site : <http://www.koblenz.electric.com>

SERVICE

KOBLENZ ELECTRICA S.A. DE C.V.

E-mail: [servicio@koblenz-electric.com](mailto:servicio@koblenz-electric.com)

LP-APVI500-200509

