

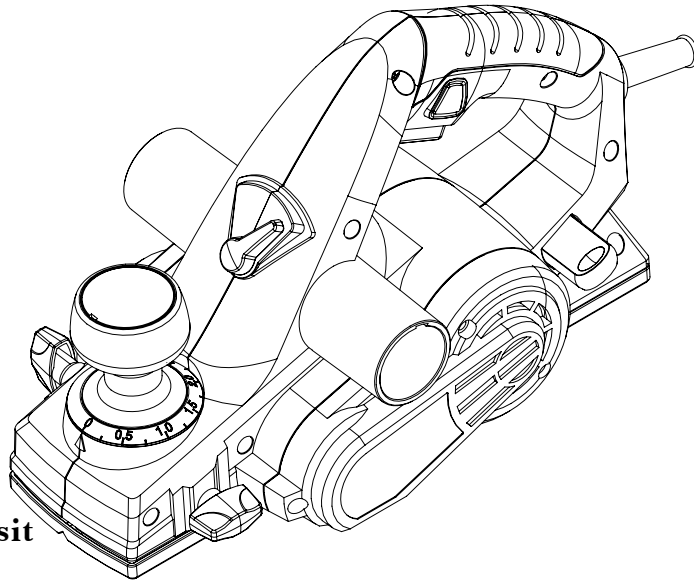

3-1/4-INCH HAND PLANER



Intertek
3148819

For replacement parts visit
WENPRODUCTS.COM

Model # 6530
bit.ly/wenvideo

IMPORTANT:

Your new tool has been engineered and manufactured to WEN's highest standards for dependability, ease of operation, and operator safety. When properly cared for, this product will supply you years of rugged, trouble-free performance. Pay close attention to the rules for safe operation, warnings, and cautions. If you use your tool properly and for intended purpose, you will enjoy years of safe, reliable service.

NEED HELP? CONTACT US!

Have product questions? Need technical support?
Please feel free to contact us at:

 **800-232-1195** (M-F 8AM-5PM CST)

 techsupport@wenproducts.com

 WENPRODUCTS.COM



TABLE OF CONTENTS

Technical Data	2
General Safety Rules	3
Specific Rules For The Planer	4
Electrical Information	6
Know Your Planer	7
Operation	8
Adjustments	12
Maintenance	14
Warranty Statement	14
Exploded View and Parts List	16

TECHNICAL DATA

Model Number:	6530
Motor:	120 V, 60 Hz, 6A
Speed:	17,000 RPM
Cutting Width:	3-1/4 in.
Cutting Depth:	1/8 in.
Rabbeting Depth:	11/16 in.
Weight:	6.5 lbs
Contents:	Hand Planer Dust Bag Rabbeting Depth Stop Parallel Guide Fence

Replacement planer blades (Model 6530B) can be ordered in two packs at wenproducts.com

GENERAL SAFETY RULES

Safety is a combination of common sense, staying alert and knowing how your item works.

SAVE THESE SAFETY INSTRUCTIONS.



WARNING! Read all safety warnings and all instructions. Failure to follow the warnings and instructions may result in electric shock, fire and serious injury. To avoid mistakes and serious injury, do not plug in your tool until the following steps have been read and understood.

WORK AREA SAFETY

1. Keep work area clean and well lit. Cluttered or dark areas invite accidents. Do not work on floor surfaces that are slippery with sawdust or wax. Keep the ground clear of tripping hazard.
2. Do not operate power tools in explosive atmospheres, such as in the presence of flammable liquids, gases or dust. Power tools create sparks which may ignite the dust or fumes.
3. Keep bystanders at a safe distance from the work area. Never allow children or pets near the tool.

ELECTRICAL SAFETY

1. Do not expose power tools to rain or wet conditions. Water entering a power tool will increase the risk of electric shock.
2. Power tool plugs must match the outlet. Never modify the plug in any way. Modified plugs with non-matching outlets will increase the risk of electric shock.
3. Check all power supplies periodically. Do not use defective cords. Damaged or entangled cords increase the risk of electric shock.
4. Do not abuse the cord. Never use the cord for carrying, pulling or unplugging the power tool. Keep cord away from heat, oil, sharp edges or moving parts.

PERSONAL SAFETY

1. Stay alert. Watch what you are doing and use common sense when operating a power tool. Do not use a power tool while you are tired or under the influence of drugs, alcohol or medication. A moment of inattention while operating power tools may result in serious personal injury.
2. Do not wear loose clothing, gloves, neckties, or jewelry (rings, watches, etc.) when operating the tool. Inappropriate clothing and items can get caught in moving parts and draw you in. Always wear non-slip footwear and tie back long hair.
3. Use personal protective equipment. Always wear safety goggles at all times that comply with ANSI Z87.1. Use ear protection such as plugs or muffs during extended periods of operation. Wear work gloves to protect your hands. Wear a face mask or dust mask to fight the dust.
4. Keep proper footing and balance at all times and do not overreach when operating the power tool.



WARNING: Dust generated from certain materials can be hazardous to your health. Always operate the tool in a well-ventilated area and wear dust mask. Use dust collection systems when processing wood and plastics. Dust extractors or dust bags must not be connected when processing metals.

GENERAL SAFETY RULES

POWER TOOL USE AND CARE

1. Avoid accidental start-ups. Make sure the power switch is in the OFF position before connecting the plug to a power source or carrying the tool.
2. Check power tool for damaged parts. Check for misalignment of moving parts, jamming, breakage, improper mounting, or any other conditions that may affect the tool's operation. Do not use the power tool if the switch does not turn ON/OFF. Any part that is damaged should be properly repaired or replaced before use.
3. Do not force the tool to do a job for which it was not designed. Use the correct power tool and accessories and follow the instructions for your application to prevent hazardous situations.
4. Remove adjustment tools. Always make sure all adjustment tools or wrenches are removed from the tool before turning on the power tool.
5. Keep guards in place and in working order before operating the tool. All protection and safety devices must be in place after completing repair and maintenance procedures
6. Never leave a running tool unattended. Do not leave the tool until it has come to a complete stop.

POWER TOOL MAINTENANCE

1. Always disconnect the power cord plug from the electrical outlet when making adjustments, changing parts, or storing power tools. Such preventive safety measures reduce the risk of starting the power tool accidentally.
2. Maintain power tools properly. Safely store power tools out of the reach of children. Always keep tools clean and in good working order. Follow instructions for lubricating and changing accessories.
3. Only have your power tool serviced by a qualified repair person using only identical replacement parts. Use of any other part can cause personal injury and damage to the tool.

SPECIFIC RULES FOR THE PLANER



WARNING: To prevent serious injury, do not operate this tool until the entire manual and all warnings have been read and understood.

WORKPIECE SAFETY

1. Secure the workpiece to a stable platform using clamps or another practical method. Never hold it in your hand or across your legs. Unstable support could result in a loss of control and personal injury.
2. Small workpieces must be adequately secured so that the rotating planer blades don't pick them up during the forward motion of the planer.
3. Check the workpiece for nails and other foreign objects. If there are nails, either remove them or set them well below the intended finished surface. Any article that encounters planer blades may be forcibly ejected from planer creating risk of injury.

SPECIFIC RULES FOR THE PLANER

OPERATION SAFETY

1. Always use ANSI Z87.1 approved safety glasses. Wear hearing protection to prevent hearing damage during operation. Use face mask or dust mask if cutting operation is dusty.
2. Keep handles and hands dry, clean and free from oil and grease. Slippery surfaces can cause you to lose control of the power tool.
3. Always hold the planer firmly with both hands for maximum control.
4. Only hold the power tool by insulated gripping surfaces in case the cutter contacts its own cord. Cutting a “live” wire may make exposed metal parts of the tool “live” and could give the operator an electric shock.
5. Always start the planer before the blade is in contact with the workpiece. Let the blade reach full speed before using the tool. The planer can vibrate and possibly kickback if the cutting speed is too slow.
6. Do not plane end grain, as the wood could splinter or possibly explode. Always plane along the grain direction of the wood, never plane against the grain direction.
7. Never pull the planer backwards over the workpiece. Loss of control may occur.
8. Do not put fingers or any objects into the chip extraction port.
9. Remove the plug from power source before removing chips. Do not clean out chips while the tool is running. Contact with the blade drum will cause injury as the blades are hidden from view and you may be cut if the blade is contacted.
10. Wait for the cutter to stop before setting the tool down. An exposed rotating cutter may engage the surface, leading to possible loss of control and serious injury.

MAINTENANCE SAFETY

1. Unplug the planer before making adjustments or changing accessories. Accidental start-ups may occur if the planer is plugged in during an accessory change.
2. Planer blades are sharp. Wear protective work gloves when removing/installing blades or turning the blade drum.
3. After changing blades, rotate the blade drum to make sure the blades don't hit any part of the blade head housing and that the blade locking screws are tight. Loose or misaligned blades have the potential to damage the tool and cause possible injury.
4. Develop a periodic maintenance schedule for your tool. When cleaning be careful not to disassemble any portion of the tool. Internal wires may be misplaced or pinched and safety guard return springs may be improperly mounted.
5. Certain cleaning agents such as gasoline, carbon tetrachloride, ammonia, etc. may damage plastic parts.

ELECTRICAL INFORMATION

GROUNDING INSTRUCTIONS

IN THE EVENT OF A MALFUNCTION OR BREAKDOWN, grounding provides the path of least resistance for an electric current and reduces the risk of electric shock. This tool is equipped with an electric cord that has an equipment grounding conductor and a grounding plug. The plug **MUST** be plugged into a matching outlet that is properly installed and grounded in accordance with **ALL** local codes and ordinances.

DO NOT MODIFY THE PLUG PROVIDED. If it will not fit the outlet, have the proper outlet installed by a licensed electrician.

IMPROPER CONNECTION of the equipment grounding conductor can result in electric shock. The conductor with the green insulation (with or without yellow stripes) is the equipment grounding conductor. If repair or replacement of the electric cord or plug is necessary, **DO NOT** connect the equipment grounding conductor to a live terminal.

CHECK with a licensed electrician or service personnel if you do not completely understand the grounding instructions or whether the tool is properly grounded.

USE ONLY THREE-WIRE EXTENSION CORDS that have three-pronged plugs and outlets that accept the tool's plug as shown in Fig. A. Repair or replace a damaged or worn cord immediately.

CAUTION: In all cases, make certain the outlet in question is properly grounded. If you are not sure, have a licensed electrician check the outlet.

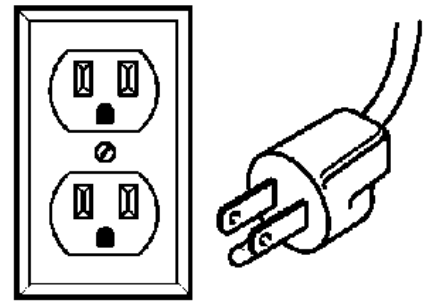

Fig. A

WARNING: This tool is for indoor use only. Do not expose to rain or use in damp locations.

GUIDELINES AND RECOMMENDATIONS FOR EXTENSION CORDS

Make sure your extension cord is in good condition. When using an extension cord, be sure to use one heavy enough to carry the current your product will draw. An undersized cord will cause a drop in line voltage resulting in loss of power and overheating. The table below shows the correct size to be used according to cord length and nameplate ampere rating. When in doubt, use a heavier cord. The smaller the gauge number, the heavier the cord.

AMPERAGE	REQUIRED GAUGE FOR EXTENSION CORDS			
	25 ft.	50 ft.	100 ft.	150 ft.
6A	18 gauge	16 gauge	14 gauge	12 gauge

Make sure your extension cord is properly wired and in good condition. Always replace a damaged extension cord or have it repaired by a qualified person before using it. Protect your extension cords from sharp objects, excessive heat and damp/wet areas.

Use a separate electrical circuit for your tools. This circuit must not be less than a #12 wire and should be protected with a 15A time-delayed fuse. Before connecting the motor to the power line, make sure the switch is in the **OFF** position and the electric current is rated the same as the current stamped on the motor nameplate. Running at a lower voltage will damage the motor.

WARNING: This tool must be grounded while in use to protect the operator from electric shock.

KNOW YOUR PLANER

Carefully unpack the hand planer from the box. Check all components and compare against the graph below. If any part is damaged or missing, please contact our customer service at (800) 232-1195, M-F 8-5 CST or email techsupport@wenproducts.com.

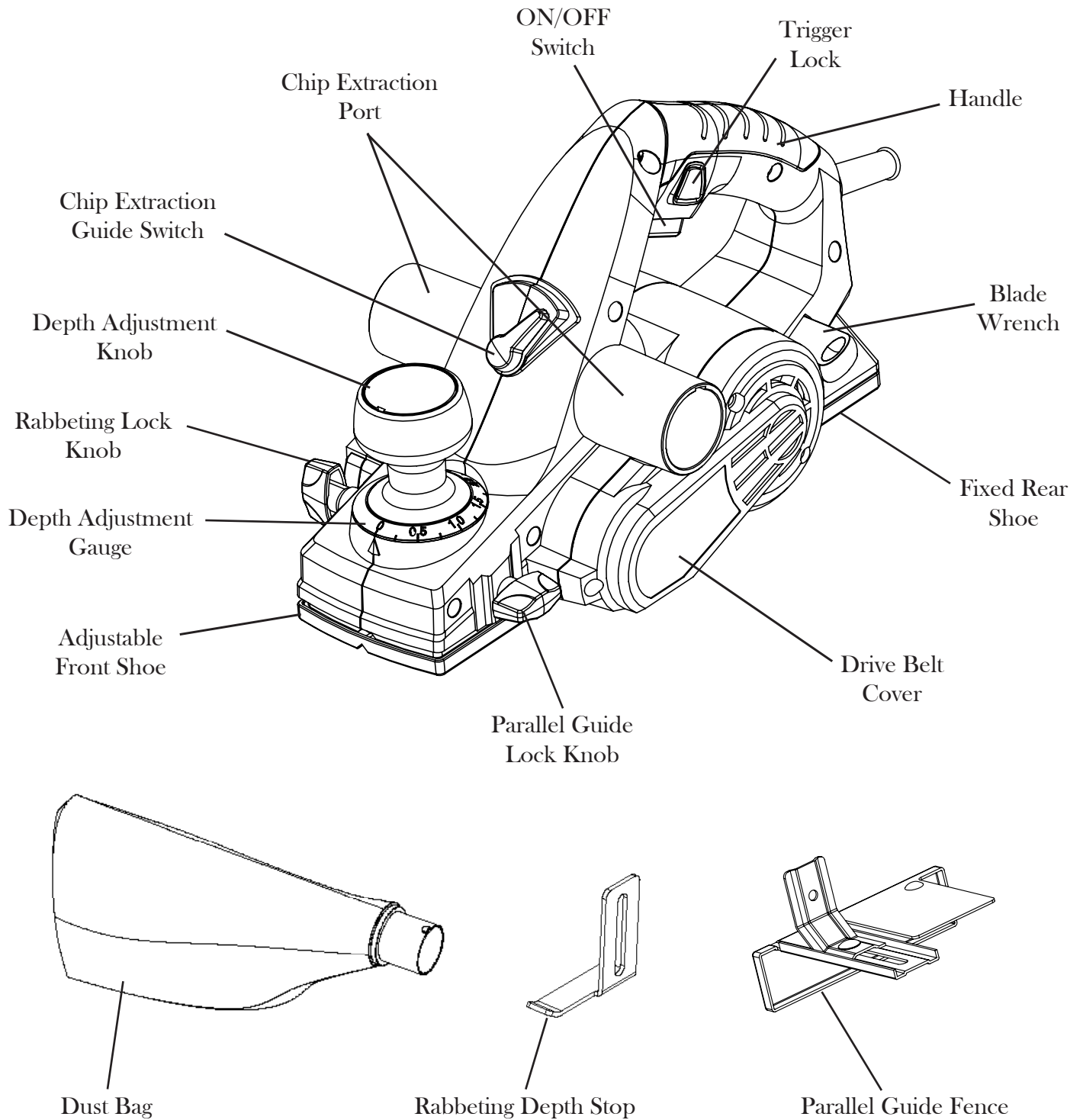

OPERATION



WARNING: To prevent serious injury, make sure all the instructions have been read and understood before operating this tool. Before plugging the machine into the power supply, always check that the trigger switch and trigger lock work properly.

USING THE SAFETY KICKSTAND

The safety kickstand (Fig. B - 1) on the back of the planer swings down to help keep the blade from coming into contact with the work surface when the planer is not in use.

The kickstand is designed to swing up and out of the way by itself when the back of the planer crosses the leading edge of the work-piece.

CONNECTING THE CHIP EXTRACTION PORT

The wood shavings can be set to flow from either side of the tool to suit the task at hand. Set the extraction guide switch (Fig. C) to point towards the extraction port that you wish the chips to flow towards.

If desired, attach the dust bag by sliding the nozzle onto the appropriate chip extraction port. For efficient operation, empty the dust bag when it is no more than half full, allowing for better airflow through the bag.

You can also connect your planer to a suitable dust extraction system through the extraction port. **Hose adaptors (not included) may be needed depending on the size of your dust hose.**

WARNING: Shavings may jam in the dust extraction port when cutting damp wood. Never stick your finger into the dust extraction port. Clean out the shavings with a stick, but only when the cutter has stopped running and the tool has been unplugged from the power source.

SWITCHING ON AND OFF

The tool is equipped with a trigger lock (Fig. D - 1) to avoid unintentional start-ups.

1. To turn the planer on, press the trigger lock (Fig. D - 1) and then squeeze the trigger switch (Fig. D - 2).

2. To switch off, release the trigger switch.

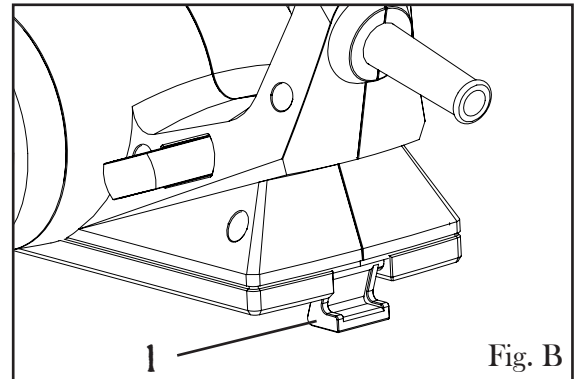

Fig. B

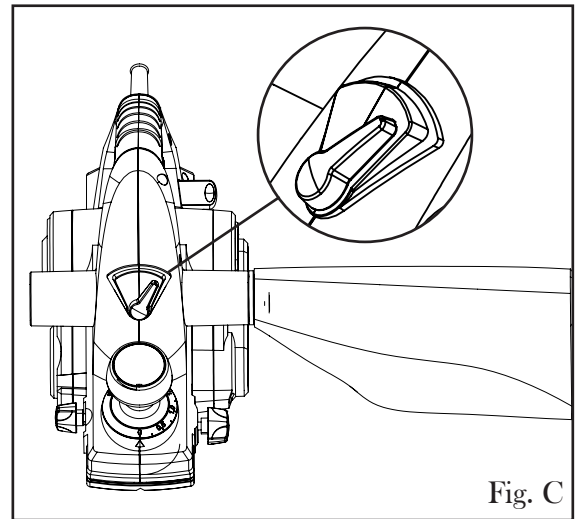

Fig. C

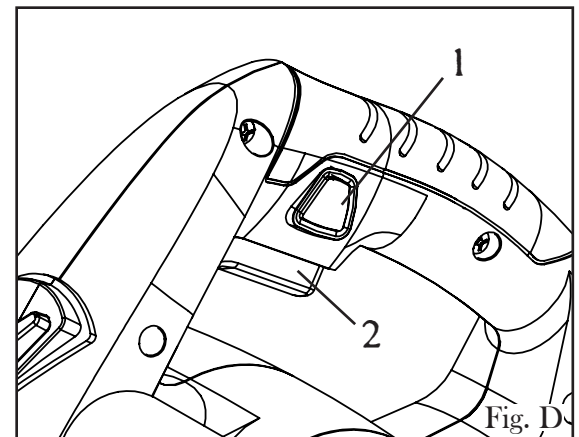

Fig. D

OPERATION

ADJUSTING THE CUTTING DEPTH

The cutting depth of a planer is determined by the height difference between the adjustable front shoe and the cutting edge of the blade. The depth adjustment knob extracts the front shoe to adjust how much blade is exposed, which determines the amount of material that will be removed. To adjust the cutting depth:

Rotate the depth adjustment knob (Fig. E - 1) until the indicator arrow (Fig. E - 2) aligns with the desired cutting depth on the depth gauge. Turn the depth adjustment knob clockwise for a deeper cut and counter-clockwise for a shallower cut.

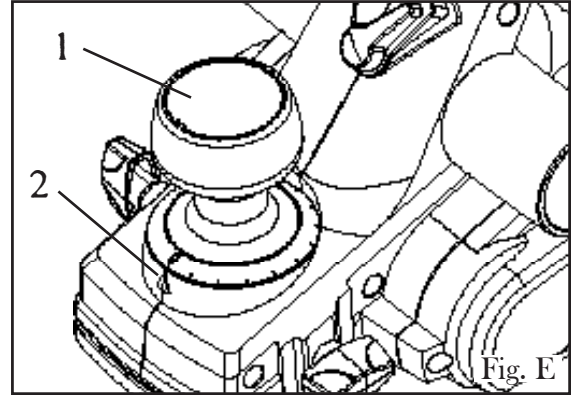

NOTE: The minimum cutting increment is 1/128 inch (0.2 mm). The maximum cutting depth of the planer is 1/8 inch. However, the more material you attempt to take off with each pass, the less even the final board will be. The appropriate cutting depth depends on the material of your workpiece. For optimum planing performance, the cutting depth should be less than 1/64 of an inch per pass. Make multiple progressive cuts, less than 1/64 inch per pass to achieve the total cutting depth. To accurately determine the depth of cut, plane a similar piece of scrap material and adjust the settings accordingly.



CAUTION: Always ensure that the number on the depth gauge is at the “0” position when the tool is not in use. However, even at “0”, a slightly protrusive blade could still make contact depending on how the blade was installed. Engage the safety kickstand to prevent the blade from contacting the workpiece.

THE DO'S AND DONT'S OF GRAIN DIRECTION

It is important that the planer should always be cutting in the same direction as the grain of the wood (Fig. F). There are six sides to every board: two face grains, two side/edge grains, and two end grains. You can plane along the direction of the grain with the face grain or side/edge grain facing upwards, but never plane with the end grain side facing upwards. Otherwise, the board has a chance of splintering and exploding inside of the planer, which could cause serious injury and damage.

When planing the face and side/edge grain, always plane in the direction of the grain. Do not plane perpendicular to the grain, otherwise the board also has a chance of splintering and exploding.



WARNING: never plane against the grain direction of the wood. Do not plane end grain, as the wood could splinter or possibly explode.

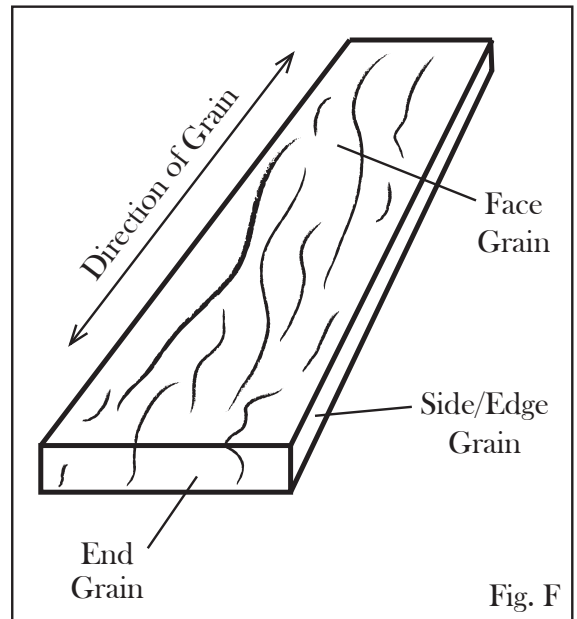

DETERMINING THE FEED RATE

The proper feed rate will depend on the type of material being cut and the depth of the cut. Moving the planer too fast may cause a poor quality of cut and can damage the blades or the motor; moving the machine too slowly may burn or mar the cut. Practice first on a scrap piece of material to gauge the correct feed rate and cutting dimensions.

OPERATION



WARNING: Wear safety goggles at all times that comply with ANSI Z87.1. Use ear protection such as plugs or muffs during extended periods of operation. Wear work gloves to protect your hands. Wear a face mask or dust mask to fight the dust.

PLANING OPERATION

1. Secure the workpiece to a stable platform. Make sure that the surface to be planed is face grain or side grain. Do not plane end grain, as the wood could splinter or possibly explode (see page 9 “The Do’s and Dont’s of Grain Direction”).
2. Hold the planer firmly with both hands. Rest the front shoe flat on the workpiece surface, ensuring that the blades do not make contact with the workpiece.
3. Switch the tool ON and wait for the blades to reach full speed.
4. Move the tool gently forward along the grain of the wood. Apply pressure on the front of the tool at the beginning of planing, and at the rear of the tool towards the end of the planing stroke.
5. Push the planer beyond the edge of the workpiece without tilting it downwards. Turn off the planer and wait for the cutter to stop before setting the tool down.

NOTE: The feed rate and the depth of cutting determine the quality of the finish. Increase the depth of cut for rough cutting and reduce the depth of the cut to achieve a smoother finish.



CAUTION: The motor may stall if improperly used or overloaded. Reduce the pressure (feed rate) or the depth of cut to prevent possible damage to the tool if the motor labors.

CHAMFERING OPERATION

The V-groove in the front shoe allows for quick and easy chamfers, creating a sloping edge on your workpiece.

1. Make sure that the workpiece is secured to a stable platform.
2. Hold the planer firmly with both hands. Align the V-groove in the front shoe of the planer with the corner edge of the workpiece (Fig. G). Be sure the blades are not touching the work. Place weight on the depth adjustment knob so that the V-groove is absolutely flat on the edge to be beveled.
3. Switch the tool ON and wait for the blades to reach full speed.
4. Push the planer forward along the grain of the wood with steady pressure on the front shoe.
5. Push the planer beyond the edge of the workpiece without tilting it downwards. Turn off the planer and wait for the cutter to stop before setting the tool down.

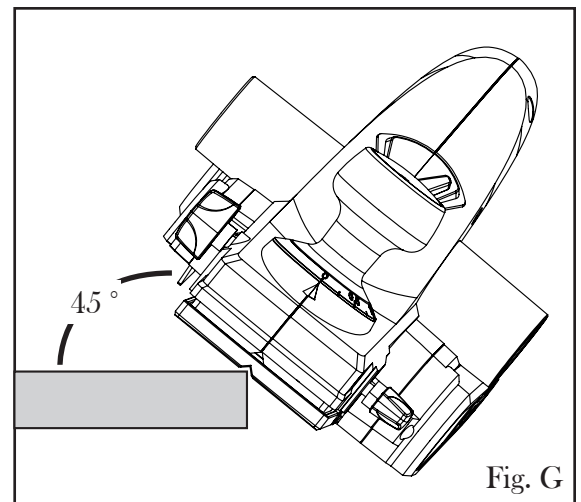

OPERATION



WARNING: To avoid injury from accidental startups, always ensure that the tool is switched OFF and unplugged from the power supply before making any adjustments to the planer.

USING THE PARALLEL GUIDE FENCE

The parallel guide fence ensures that the planer travels parallel to the edge of the wood, providing a straight cut at your desired cutting width. This feature is helpful for planing door edges, wood trim and boards. To attach the parallel guide fence:

1. Disconnect the planer from the power source.
2. Attach the parallel guide fence to the left-hand side of the planer using the lock knob (Fig. H - 1).
3. Loosen the wing nut (Fig. I - 1) on the parallel guide fence and slide the fence to set the desired cutting width indicated by the width gauge. Retighten the wing nut.

NOTE: To ensure a square cut, measure the front and back of the fence and use a square to make sure the guide is set straight.

4. Rest the front shoe flat on the workpiece surface and position the fence firmly against the edge of the workpiece (Fig. I). Follow instructions on page 10 “Planing Operation” to perform your cut.

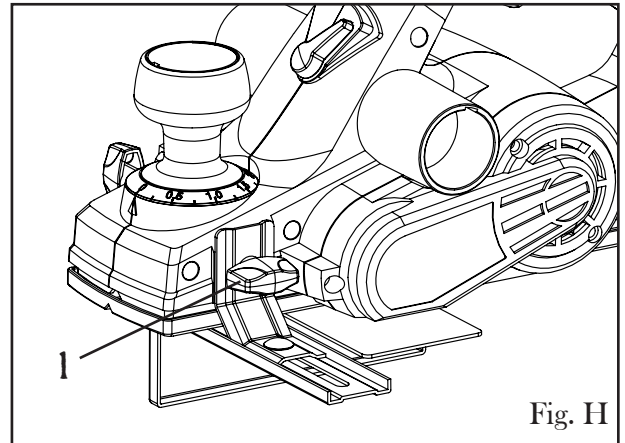

Fig. H

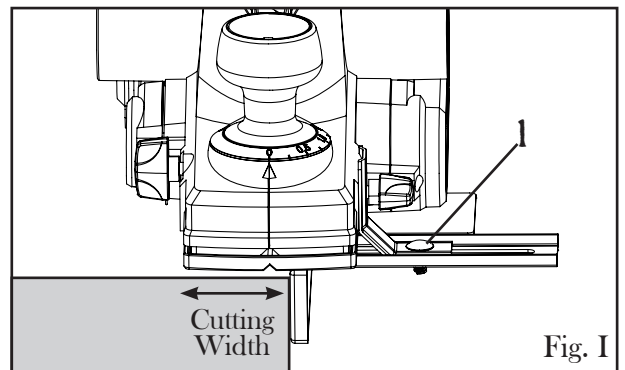

Fig. I

USING THE RABBETING DEPTH GUIDE

The rabbeting depth guide can be adjusted anywhere from 0 to 7/10 of an inch above the bottom plane of the front shoe. To attach the rabbeting depth guide:

1. Disconnect the planer from the power source.
2. Attach the rabbeting depth gauge to the right-hand side of the planer using the lock knob (Fig. J - 1). Position the rabbeting depth gauge to the desired depth against the rabbet level tick mark on the side housing. Then tighten the lock knob.
3. If desired, use the parallel guide fence in conjunction with the rabbeting depth guide to create a straight rabbeting cut.
4. Make multiple progressive cuts to achieve the total cutting depth. The required rabbeting depth is achieved when the depth gauge is flush with the unplanned section of the workpiece to the right-hand side of the tool (Fig. K).

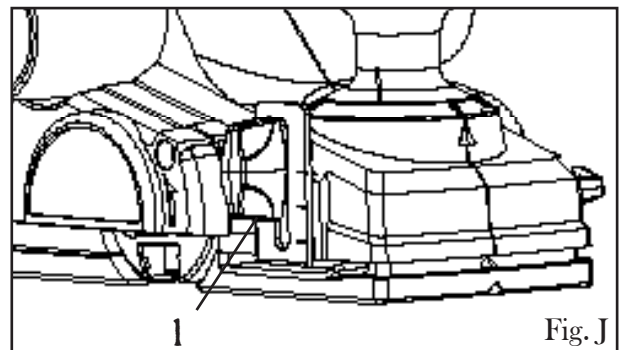

Fig. J

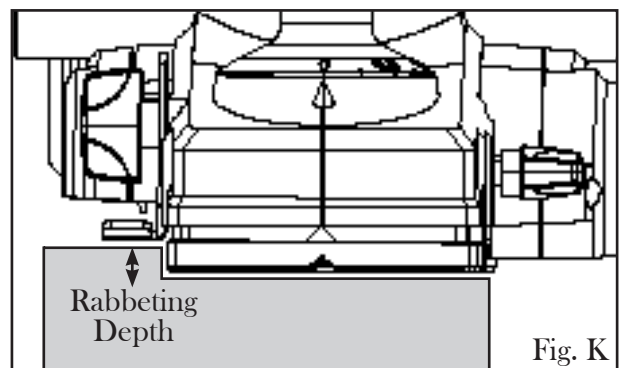

Fig. K

NOTE: The rabbeting depth gauge allows only approximate depth settings. If it is necessary to rabbet to a precise depth, plane a scrap piece of wood, measure the rabbeted depth, and adjust the setting as necessary.

ADJUSTMENTS



WARNING: To avoid injury from accidental startups, always ensure that the tool is switched OFF and unplugged from the power supply before making adjustments or installing or removing blades.

REMOVING OR INSTALLING PLANER BLADES



WARNING: Planer blades are sharp and fragile. Wear protective gloves to protect your hands. Handle the blades carefully to avoid personal injury or damage to the blades.



WARNING: Do not attempt to sharpen or use resharpened blades of any kind. Use only blades designed for use with this model. Other blades may not clamp securely in the blade holder, causing vibration and a decrease in performance.

Condition of blades will affect the precision of cuts. Observe the quality of the cut that the planer produces to check the condition of the blades. Dull blades will tear wood fibers and produce fuzzy surfaces. Raised grain will occur on the wood when the cutting blades are dull or have been nicked.

NOTE: Blades on this planer are reversible and should always be reversed or replaced as a matched set. Unbalanced blades can cause vibration and poor planing action while shortening the life of the blade and the tool. Keeping a spare set of blades on hand is recommended. Replacement blades (Model 6530B) can be ordered in two packs at wenproducts.com.

1. Disconnect the planer from the power source.
2. Put the planer on a secure work surface and turn it upside down. Carefully rotate the blade drum to expose the clamping screws (Fig. L - 1).
3. Loosen the three clamping screws using the onboard blade wrench located on the back of the planer. Rotate the blade wrench towards the blade guard side to loosen the screw (Fig. M).

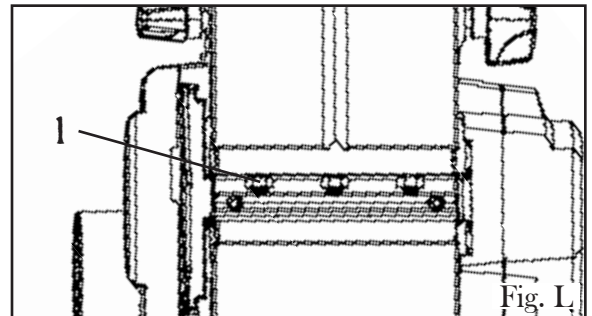

CAUTION: The blade drum can rotate so be careful not to contact the blade with your hand. If the screw is difficult to loosen, try tightening it a little and then loosen it.

4. Hold the blade drum in place and carefully slide the blade (Fig. N - 1) out towards the blade guard side. You can also use a wooden block to push the blade out of the blade drum.
5. Clean out all chips or foreign matter adhering to the blade drum and the blade using a soft brush or compressed air.
6. Each planer blade has two cutting edges and may be reversed when one of the cutting edges becomes dull or chipped.

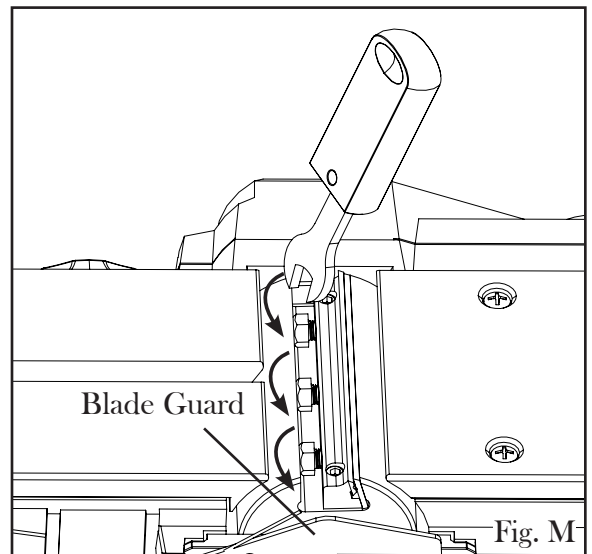

- If one edge is dull, reverse the blade.
- If both edges are dull, remove the old blade and replace it with a new one.

(Continued on the next page)

ADJUSTMENTS



WARNING: To avoid injury from accidental startups, always ensure that the tool is switched OFF and unplugged from the power supply before making adjustments or installing or removing blades.

7. Slide the blade with the good side up into the blade retainer of the blade drum (Fig. N). **NOTE:** The flat side of the blade should be facing the front of the planer and the ridged side of the blade should be facing the back of the planer.

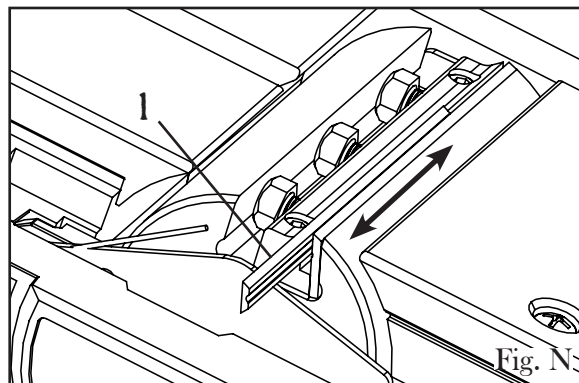

8. To ensure an even cut, the blade should align with the outside edge of the front and rear shoes. Place a straight edge along the outside edge of the front and rear shoe (Fig. O). Slide the planer blade to just contact the straight edge so that it is in line with the outside edge of the shoes.

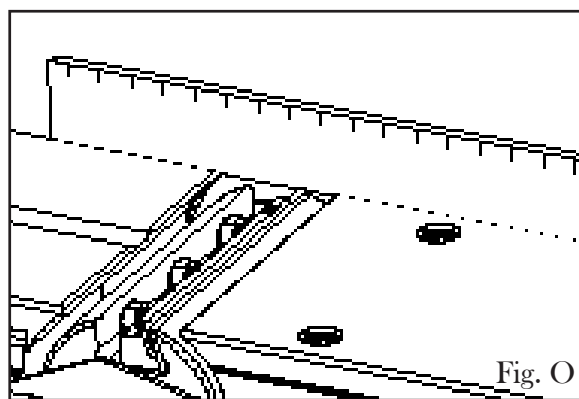

9. The blades must be mounted so that the cutting edge is absolutely level (parallel to the surface of the rear shoe). Check that both ends of the blade protrude out evenly from the blade retainer of the blade drum.

NOTE: The planed surface will end up rough and uneven if blades are not set properly or securely.

10. Tighten the clamping screws using the blade wrench, ensuring that all three screws are tightened evenly (Fig P).

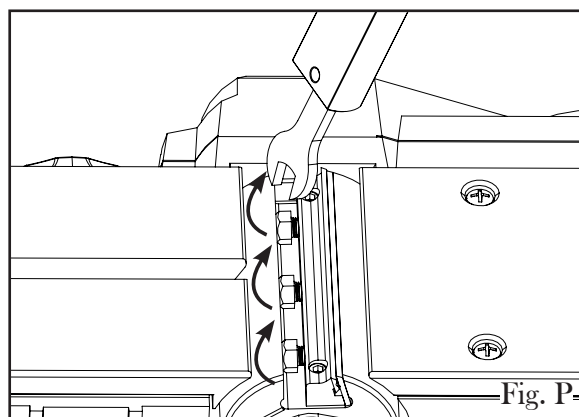

11. Repeat steps 2 - 10 for the installing/changing the second blade. It is important to reverse or replace the two blades at the same time so they are balanced with one another. Both blades should be set to the same cutting level and alignment, otherwise the planed surface will be rough and uneven.



CAUTION: Tighten all clamping screws carefully when attaching the blades to the planer. A loose clamping screw can be extremely dangerous. Check regularly to make sure that all six clamping screws are tightened securely.

MAINTENANCE



WARNING: To prevent serious injury from accidental operation, make sure that the planer is turned off and unplugged from power source before installation, cleaning and maintenance operations.



WARNING: Preventive maintenance performed by unauthorized personnel may result in misplacing of internal wires and components, possibly causing a serious hazard. We recommend that all tool service be performed by a WEN Service Center.

CLEANING

Keep the planer clean of any wood chips, dust, dirt or debris. Ventilation openings and switch levers must be kept clean and free of foreign matter. The tool may be cleaned most effectively with compressed dry air. Always wear safety goggles when cleaning tools with compressed air. Do not attempt to clean these components by inserting pointed objects through openings.



WARNING: Certain cleaning agents and solvents damage plastic parts. Some of these are: gasoline, carbon tetrachloride, chlorinated cleaning solvents, ammonia and household detergents that contain ammonia.

CARBON BRUSHES

To maintain maximum efficiency of the motor, we recommend changing the carbon brushes every 60 hours of operation. Replacement carbon brushes (Model 6530-038) are available at wenproducts.com. Only genuine WEN replacement brushes designed specifically for your tool should be used. To inspect or replace the carbon brushes:

1. Unscrew and open the motor cover on the right (Fig. Q).
2. Carefully take out the two carbon brushes (Fig. R - 1) using pliers and replace with new brushes.
3. Replace the motor cover and secure with screws.

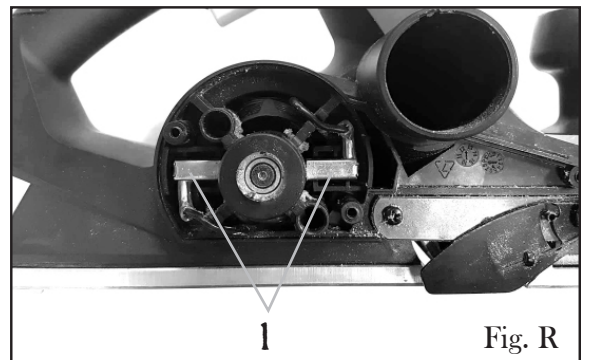
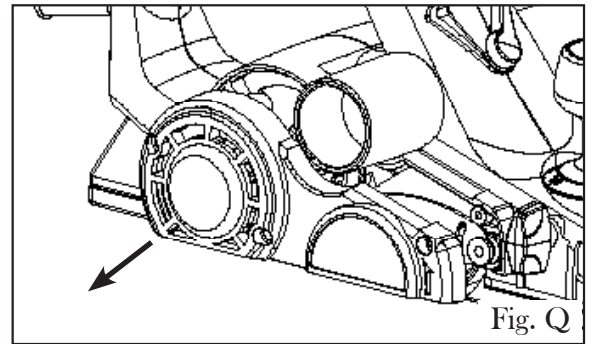

TOOL LUBRICATION

Your tool has been properly lubricated and is ready to use. It is recommended that tools with gears be regreased with a special gear lubricant at every carbon brush change.

DRIVE BELT

Inspect the drive belt every 60 hours of use. If the drive belt shows signs of drying out, cracking, tearing or improper tracking, it should be replaced. To replace the drive belt, unscrew and open the belt cover on the left (Fig. S). Replace with identical replacement belt and close the drive belt cover.

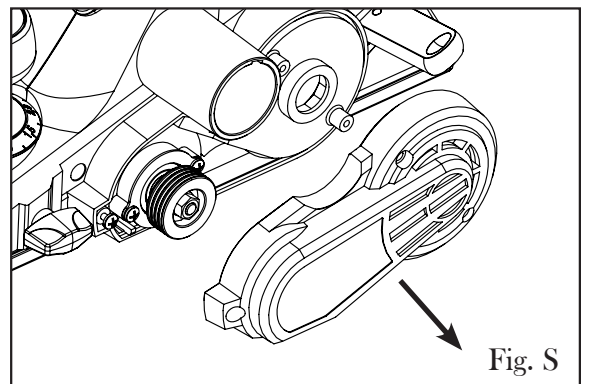

BEARINGS

Bearings that become noisy (due to heavy load or abrasive material cutting) should be replaced by a qualified technician as soon as possible to avoid overheating or motor failure.

LIMITED ONE YEAR WARRANTY

WEN Products is committed to building tools that are dependable for years. Our warranties are consistent with this commitment and our dedication to quality.

LIMITED WARRANTY OF WEN CONSUMER POWER TOOLS PRODUCTS FOR HOME USE

GREAT LAKES TECHNOLOGIES, LLC (“Seller”) warrants to the original purchaser only, that all WEN consumer power tools will be free from defects in material or workmanship for a period of one (1) year from date of purchase. Ninety days for all WEN products, if the tool is used for professional use.

SELLER’S SOLE OBLIGATION AND YOUR EXCLUSIVE REMEDY under this Limited Warranty and, to the extent permitted by law, any warranty or condition implied by law, shall be the repair or replacement of parts, without charge, which are defective in material or workmanship and which have not been misused, carelessly handled, or misrepaired by persons other than Seller or Authorized Service Center. To make a claim under this Limited Warranty, you must make sure to keep a copy of your proof of purchase that clearly defines the Date of Purchase (month and year) and the Place of Purchase. Place of purchase must be a direct vendor of Great Lakes Technologies, LLC. Third party vendors such as garage sales, pawn shops, resale shops, or any other secondhand merchant void the warranty included with this product. Contact techsupport@wenproducts.com or 1-800-232-1195 to make arrangements for repairs and transportation.

When returning a product for warranty service, the shipping charges must be prepaid by the purchaser. The product must be shipped in its original container (or an equivalent), properly packed to withstand the hazards of shipment. The product must be fully insured with a copy of the warranty card and/or the proof of purchase enclosed. There must also be a description of the problem in order to help our repairs department diagnose and fix the issue. Repairs will be made and the product will be returned and shipped back to the purchaser at no charge.

THIS LIMITED WARRANTY DOES NOT APPLY TO ACCESSORY ITEMS THAT WEAR OUT FROM REGULAR USAGE OVER TIME INCLUDING BELTS, BRUSHES, BLADES, ETC.

ANY IMPLIED WARRANTIES SHALL BE LIMITED IN DURATION TO ONE (1) YEAR FROM DATE OF PURCHASE. SOME STATES IN THE U.S., SOME CANADIAN PROVINCES DO NOT ALLOW LIMITATIONS ON HOW LONG AN IMPLIED WARRANTY LASTS, SO THE ABOVE LIMITATION MAY NOT APPLY TO YOU.

IN NO EVENT SHALL SELLER BE LIABLE FOR ANY INCIDENTAL OR CONSEQUENTIAL DAMAGES (INCLUDING BUT NOT LIMITED TO LIABILITY FOR LOSS OF PROFITS) ARISING FROM THE SALE OR USE OF THIS PRODUCT. SOME STATES IN THE U.S. AND SOME CANADIAN PROVINCES DO NOT ALLOW THE EXCLUSION OR LIMITATION OF INCIDENTAL OR CONSEQUENTIAL DAMAGES, SO THE ABOVE LIMITATION OR EXCLUSION MAY NOT APPLY TO YOU.

THIS LIMITED WARRANTY GIVES YOU SPECIFIC LEGAL RIGHTS, AND YOU MAY ALSO HAVE OTHER RIGHTS WHICH VARY FROM STATE TO STATE IN THE U.S., PROVINCE TO PROVINCE IN CANADA AND FROM COUNTRY TO COUNTRY.

THIS LIMITED WARRANTY APPLIES ONLY TO PORTABLE ELECTRIC TOOLS, BENCH POWER TOOLS, OUTDOOR POWER EQUIPMENT AND PNEUMATIC TOOLS SOLD WITHIN THE UNITED STATES OF AMERICA, CANADA AND THE COMMONWEALTH OF PUERTO RICO. FOR WARRANTY COVERAGE WITHIN OTHER COUNTRIES, CONTACT THE WEN CUSTOMER SUPPORT LINE.

EXPLODED VIEW AND PARTS LIST

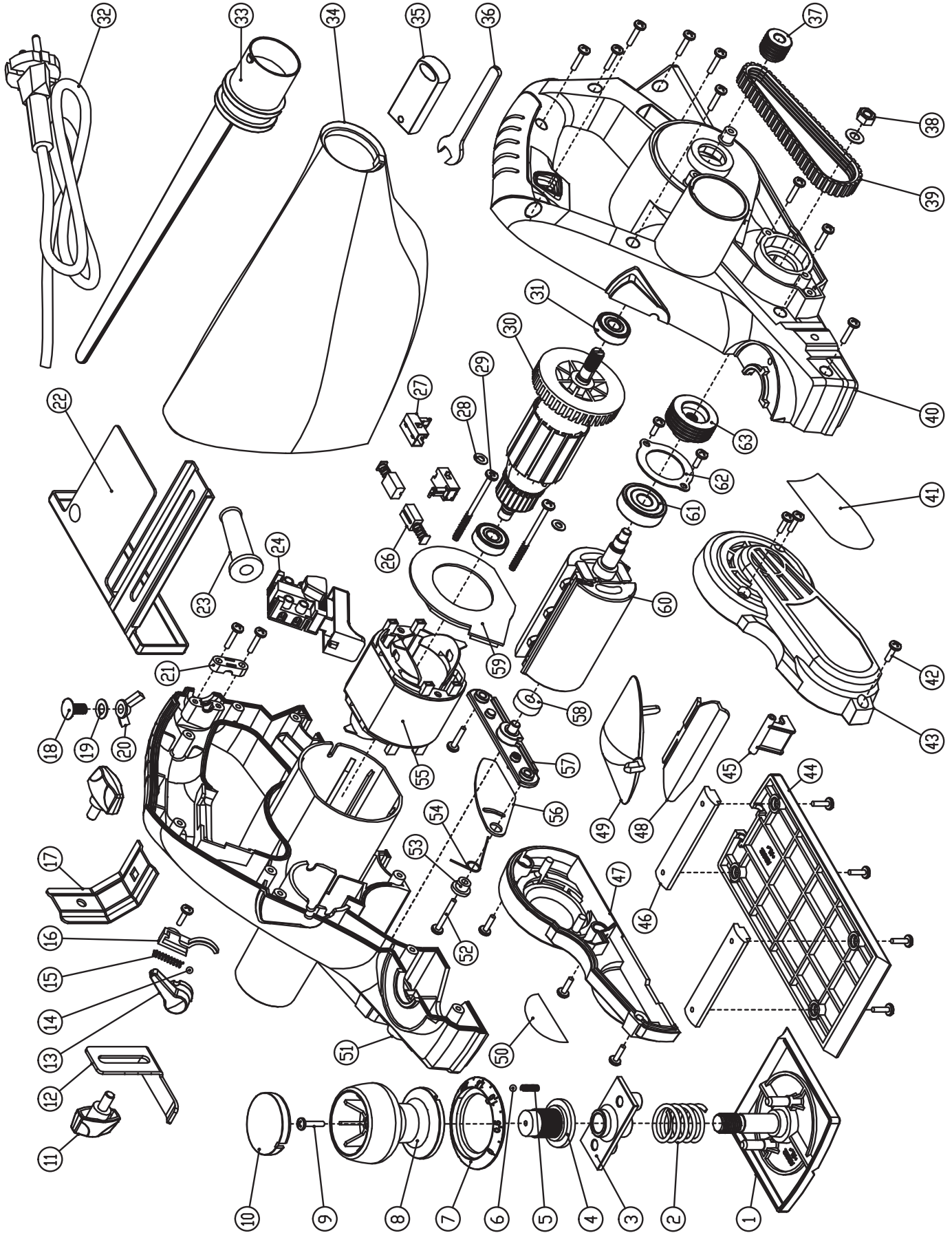

EXPLODED VIEW AND PARTS LIST

No.	Part No.	Description	Qty.	No.	Part No.	Description	Qty.
1	6530-013	Front Shoe	1	33	6530-067	Connecting Hose	1
2	6530-014	Adjust Spring	1	34	6530-068	Dust Bag	1
3	6530-015	Adjust Support	1	35	6530-064	Wrench Box	1
4	6530-008	Regulative Shaft	1	36	6530-063	Blade Wrench 40MN	1
5	6530-012	Front Shoe Ball Spring	1	37	6530-032	Driving Wheel	1
6	6530-010	Ball III3.5	1	38	6530-029	Nut M6	1
7	6530-009	Graduation Ring	1	39	6530-016	Belt	1
8	6530-007	Adjust Knob	1	40	6530-030	Left Housing	1
9	6530-004	Screw St4x16	13	41	6530-041	Logo Sticker	1
10	6530-006	Knob Cover	1	42	6530-042	Screw St4x13	13
11	6530-065	Lock Knob	2	43	6530-017	Belt Cover	1
12	6530-062	Depth Scale	1	44	6530-051	Rear Shoe	1
13	6530-057	Extraction Guide Knob	1	45	6530-046	Tool Park Rest	1
14	6530-011	Ball III4	1	46	6530-052	Panel Strip	2
15	6530-055	Extraction Guide Ball Spring	1	47	6530-002	Motor Cover	1
16	6530-056	Spring Seat	1	48	6530-048	Adjusting Plate Knob	1
17	6530-059	Fixation Frame	1	49	6530-054	Adjusting Plate	1
18	6530-060	Bolt M6x12	1	50	6530-001	Nameplate	1
19	6530-028	Washer 6	2	51	6530-005	Right Housing	1
20	6530-058	Thumb Nut M6	1	52	6530-070	Screw St4x25	1
21	6530-040	Cable Clamp	1	53	6530-018	Lock Sleeve	1
22	6530-061	Rabbeting Depth Stop	1	54	6530-019	Torsional Spring	1
23	6530-053	Cable Bushing	1	55	6530-037	Stator	1
24	6530-044	On/Off Switch	1	56	6530-020	Blade Guard	1
26	6530-038	Carbon Brush	2	57	6530-021	Tool Carrier	1
27	6530-039	Brush Lining	2	58	6530-022	Blade Drum Bearing 1	1
28	6530-036	Washer 4	2	59	6530-031	Air Deflector	1
29	6530-035	Screw St4x55	2	60	6530-023	Cutter Drum	1
30	6530-034	Rotor	1	61	6530-024	Blade Drum Bearing 2	1
31	6530-033	Rotor Ball Bearing	2	62	6530-026	Big Washer	1
32	6530-066	Power Cord	1	63	6530-027	Belt Pulley	1
				64	6530B	PlanerBlades(Not Pictured)	2

**THANKS FOR
REMEMBERING**

