



Item #699030

Model #AGL07908K01

USE AND CARE GUIDE

CAROL STREAM OTTOMAN / COFFEE TABLE

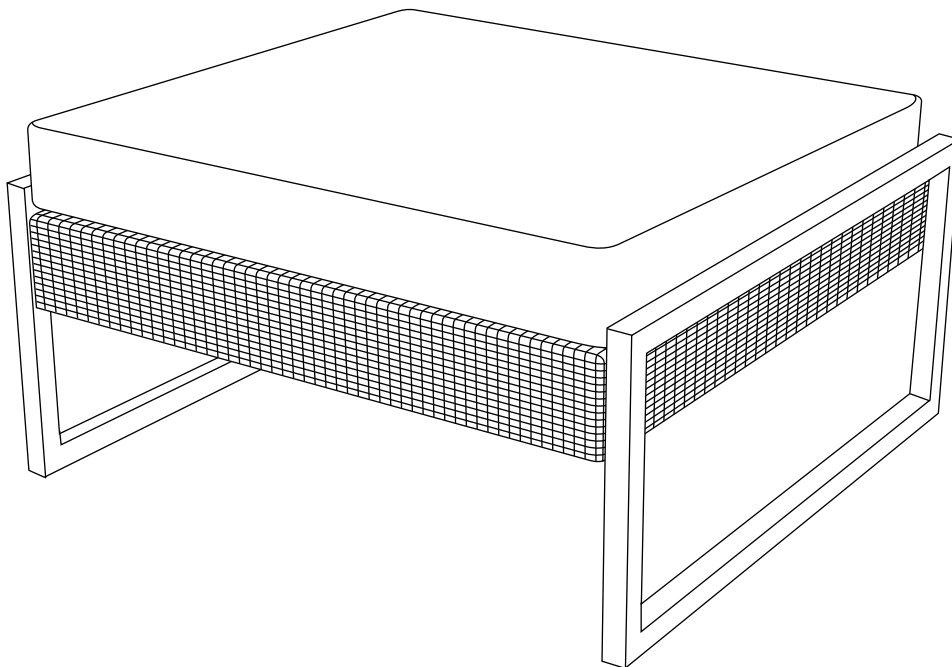

Questions, problems, missing parts? Before returning to the store,
call Hampton Bay Customer Service
8 a.m. - 7 p.m., EST, Monday - Friday, 9 a.m. - 6 p.m., EST, Saturday

1-855-HD-HAMPTON

HAMPTONBAY.COM

THANK YOU

We appreciate the trust and confidence you have placed in Hampton Bay through the purchase of this ottoman.

We strive to continually create quality products designed to enhance your home.

Visit us online to see our full line of products available for your home improvement needs.

Thank you for choosing Hampton Bay!

Table of Contents

Table of Contents.....	2	Assembly.....	5
Warranty	2	Maintenance	6
What is Covered	2	Care and Cleaning	6
What is Not Covered	2		
Pre-Assembly	3		
Planning Assembly.....	3		
Hardware Included.....	3		
Package Contents.....	4		

Warranty

3 Year Frame / 2 Year Fabric / 2 Year Wicker Limited Warranty

What is Covered

We warrant the frame to be free of manufacturing defects to the original purchaser for three years and the fabric and wicker for two years.

What is Not Covered

It remains the customer's responsibility for freight and packaging charges to and from our service center. This warranty does not cover commercial use, hardware, acts of nature, fire, freezing and abusive use. In addition, purchased parts are not covered under this warranty. We reserve the right to make substitutions with similar merchandise, if the model in question is no longer in production.

Contact Customer Care at 1-855-HD-HAMPTON or visit www.HamptonBay.com.

Pre-Assembly

PLANNING ASSEMBLY

Identify all parts packed in the carton against the parts list. Remove all protective materials. Place parts on a non-abrasive surface to avoid scratching. If you are missing any parts or are unsure how to proceed with the assembly, call our Customer Service Team at 1-855-HD-HAMPTON. Do not attempt assembly if any parts are missing or damaged.

Two people may be required to assemble the ottoman.

Damage to welds or frames resulting from over tightened bolts or improper assembly is not covered under our warranty. Please read all instructions carefully before assembly. If you have any questions regarding your assembly, call our Customer Service Team at 1-855-HD-HAMPTON.

HARDWARE INCLUDED



NOTE: Hardware not shown to actual size.

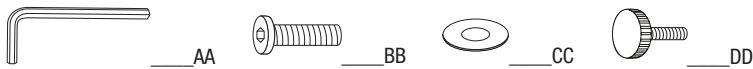

Part	Description	Order Part #	Quantity
AA	Hex Bolt Driver	HW0006	1
BB	1/4 in. x 30 mm Bolt	HW0038	8
CC	Ø6.5 x 1.0 mm Washer	HW0004	8
DD	Foot Cap (Preassembled)	FC0033	4

Pre-Assembly (continued)

PACKAGE CONTENTS

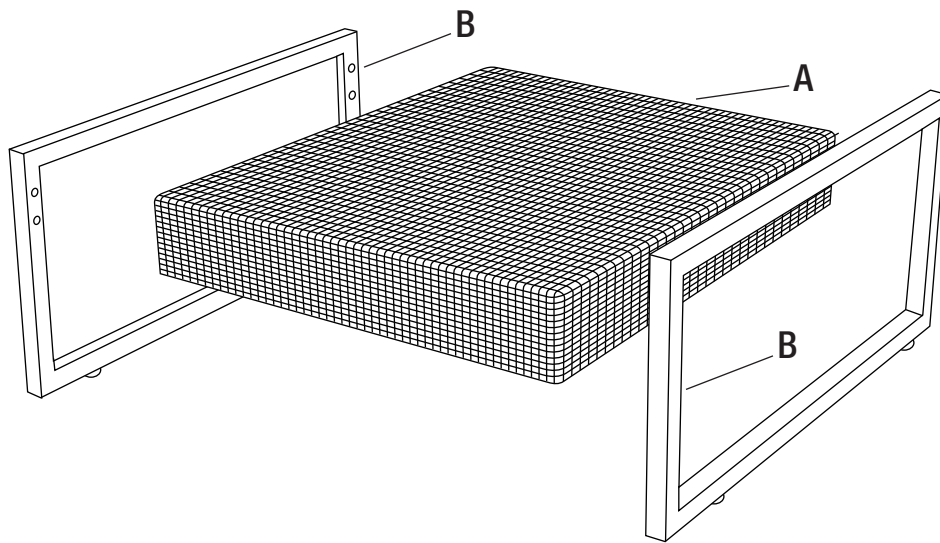

Part	Description	Order Part #	Quantity
A	Ottoman Frame	AA0620	1
B	Ottoman Leg	AA0621	2

Assembly

1 Attaching the legs

- Attach an ottoman leg (B) to the ottoman frame (A) by using four 1/4 in. x 30 mm bolts (BB) and Ø6.5 x 1.0 mm washers (CC).
- Guide the bolts (AA) through the holes in the ottoman frame (A) into the pre-drilled holes in the ottoman leg (B).
- Hand tighten only.
- Repeat for the other leg (B).

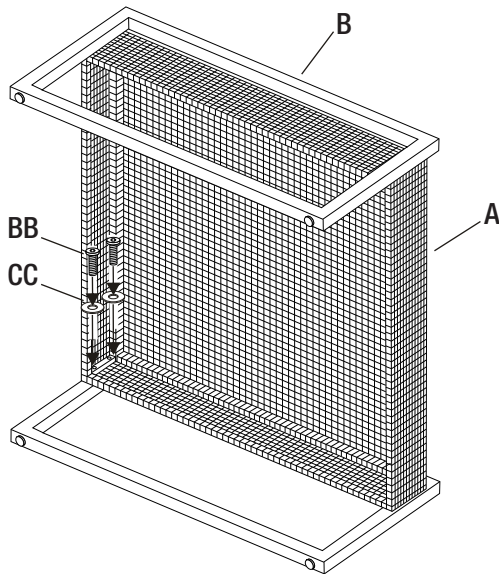

2 Tightening the bolts

- After making any necessary adjustments to the alignment of the chair, use the hex bolt driver (AA) to tighten all bolts (BB). Tighten each bolt a few revolutions at a time. In order to apply equal pressure to all bolt joints, we recommend working in a cross corner (X) pattern. Repeat until all bolts are tight. Do not over tighten. Over tightening may strip bolts.

Maintenance

FRAME:

Periodically clean and dry thoroughly. Be sure to drain any water accumulated inside the frames. To thoroughly drain the frames, remove the foot caps and tilt the frames, if necessary, to remove all water. This is critical. Water allowed to accumulate inside the frames and then exposed to sub-freezing temperatures can cause damage to the frame tubing. Such damage is not covered under the warranty. Always clean, drain, and dry thoroughly before storing for the winter. For best results, always store or cover your furniture when not in use. We recommend commercially available outdoor furniture covers. Any small nicks or scratches can be covered with a light application of touchup paint.

FABRIC (CUSHIONS/SLINGS):

The best way to maintain the appearance of cushions and slings is to store them in a dry area and out of the elements when not in use or cover with commercially available outdoor furniture covers.

Care and Cleaning

FRAME:

Use mild soap and warm water. Do not use abrasive materials, cleansers, or bleach products. Rinse with clean water and dry thoroughly.

FABRIC (CUSHIONS/SLINGS):

Wipe minor spills immediately. Clean with mild soap, warm clean water, and a soft cloth. Do not use abrasive materials, cleansers, or bleach products. Although fabric has been treated to resist stains, occasional use of commercially available fabric cleaners may be necessary. Follow the manufacturer's instructions.



Questions, problems, missing parts? Before returning to the store,
call Hampton Bay Customer Service
8 a.m. - 7 p.m., EST, Monday - Friday, 9 a.m. - 6 p.m., EST, Saturday

1-855-HD-HAMPTON

HAMPTONBAY.COM

Retain this manual for future use.