

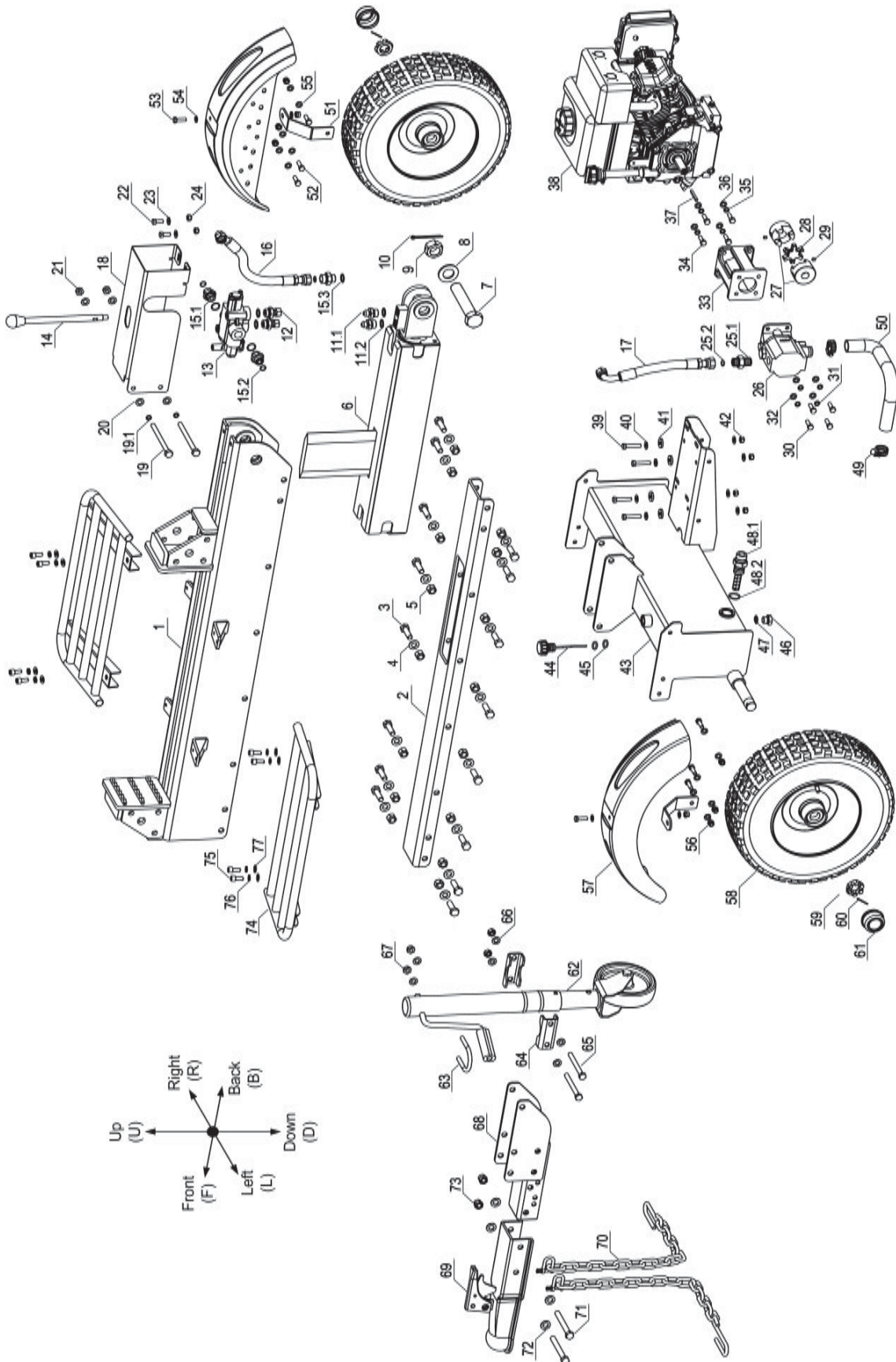





# EXPLODED DIAGRAM & PARTS LIST

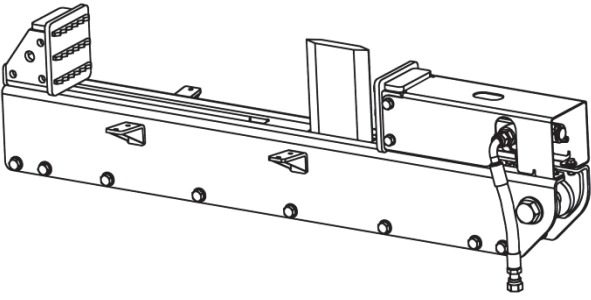
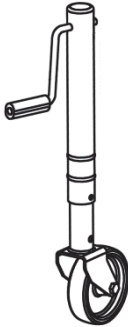
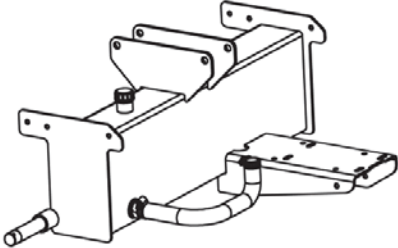
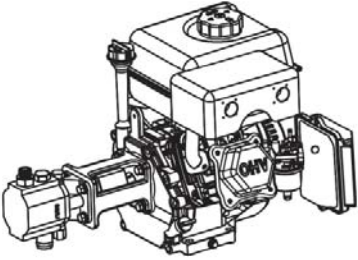
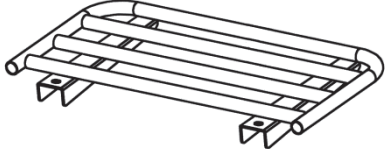
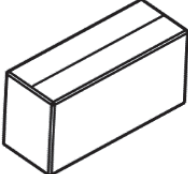

| REF # | PART #  | PART NAME                                     | SPECIFICATIONS           | QTY PER UNIT |
|-------|---------|---|--------------------------|--------------|
| 1     | 310-850 | Machine Body incl. End Plates 13 Ton          | 115*298*6mm/130*140*10   | 1            |
|       | 310-853 | Machine Body incl. End Plates 16 Ton          | 130*307*8mm/150*140*10   |              |
| 2     | 310-851 | Machine Body Bottom 13 Ton                    | W100                     | 1            |
|       | 310-854 | Machine Body Bottom 16 Ton                    | W114                     |              |
| 3     | 710-438 | Hex Head Bolt                                 | ZP, M12*35               | 16           |
| 4     | 750-621 | Flat Washer                                   | ZP, M12                  | 16           |
| 5     | 720-536 | Lock Nut                                      | ZP, M12                  | 16           |
| 6     | 530-480 | Cylinder, 13 Ton                              | 3.0 in.                  | 1            |
|       | 530-482 | Cylinder, 16 Ton                              | 3.5 in.                  |              |
| 7     | 760-137 | Pin, 13 TON                                   | PH, M27*141              | 1            |
|       | 760-132 | Pin, 16 TON                                   | PH, M32*165              |              |
| 8     | 750-623 | Flat Washer, 13 Ton                           | PH, M27*4                | 1            |
|       | 750-677 | Flat Washer, 16 Ton                           | PH, M32*6                |              |
| 9     | 720-815 | Bored Nut, 13 Ton                             | PH, M27                  | 1            |
|       | 720-872 | Bored Nut, 16 Ton                             | PH, M32                  |              |
| 10    | 760-744 | Split Pin                                     | Ø4*50                    | 1            |
| 11.1  | 510-211 | Hydraulic Adaptor                             | Straight, Hex24          | 2            |
| 11.2  | 730-077 | O Seal Ring                                   | Ø21*2.4                  | 4            |
| 12    | 510-224 | Hydraulic Adaptor                             | Straight Swing, Hex24/19 | 2            |
| 13    | 520-766 | Hydraulic Valve                               |                          | 1            |
| 14    | 520-405 | Control Handle Lever                          | Ø15*264                  | 1            |
| 15.1  | 510-448 | Hydraulic Adaptor                             | Straight, Hex27*36.5     | 3            |
| 15.2  | 730-619 | O Seal Ring                                   | Ø15*1.9                  | 3            |
| 15.3  | 730-077 | O Seal Ring                                   | Ø21*2.4                  | 3            |
| 16    | 560-409 | Hydraulic Hose (Valve - Reservoir)            | 1/2**350                 | 1            |
| 17    | 560-403 | Hydraulic Hose (Pump - Valve)                 | 1/2**300                 | 1            |
| 18    | 350-200 | Valve Cover 13 Ton                            | W118                     | 1            |
|       | 350-203 | Valve Cover 16 Ton                            | W135                     |              |
| 19    | 710-669 | Hex Head Bolt 13 Ton                          | ZP, M10*130 (8.8)        | 2            |
|       | 710-614 | Hex Head Bolt 16 Ton                          | ZP, M8*15                |              |
| 19.1  | 750-834 | Spring washer 16 Ton                          | ZP, M8                   | 4            |
| 20    | 750-525 | Flat Washer, 13 Ton                           | ZP, M10                  | 4            |
|       | 750-638 | Flat Washer, 16 Ton                           | ZP, M8                   |              |
| 21    | 720-120 | Lock Nut 13 Ton                               | ZP, M10                  | 2            |
| 22    | 710-637 | Hex Head Bolt                                 | ZP, M8*20 (8.8)          | 2            |
| 23    | 750-638 | Flat Washer                                   | ZP, M8                   | 2            |
| 24    | 720-500 | Lock Nut                                      | ZP, M8                   | 2            |
| 25.1  | 510-432 | Hydraulic Adapter on Pump for Connecting Hose | Straight, Hex27*45       | 1            |
| 25.2  | 730-619 | O Seal Ring                                   | Ø15*1.9                  | 1            |
| 26    | 550-308 | Two Stage Pump                                | 9 gpm (13T)              | 1            |
|       | 550-412 | Two Stage Pump                                | 11 gpm (16T)             |              |
| 27    | 550-702 | Coupling Shaft                                | 3/4"                     | 1            |
| 28    | 550-706 | Coupling Spider                               |                          | 1            |
| 29    | 740-600 | Set Screw                                     | Black Oxide, M6*10       | 2            |
| 30    | 710-637 | Hex Head Bolt                                 | ZP, M8*20 (8.8)          | 4            |
| 31    | 750-834 | Spring Washer                                 | ZP, M8                   | 4            |
| 32    | 750-638 | Flat Washer                                   | ZP, M8                   | 4            |
| 33    | 550-814 | Pump Mount                                    | Al                       | 1            |
| 34    | 710-632 | Hex Head Bolt                                 | ZP, 5/16-24*20 (8.8)     | 4            |
| 35    | 750-844 | Spring Washer                                 | Zinc, 5/16               | 4            |
| 36    | 750-617 | Flat Washer                                   | ZP, 5/16                 | 4            |

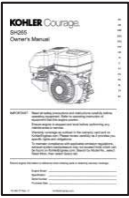
| REF # | PART NAME | SPECIFICATIONS               | QTY PER UNIT             |    |
|-------|-----------|------------------------------|--------------------------|----|
| 37    | 770-123   | Engine Shaft Square Key      | 3/16 X 1.75              | 1  |
| 38    | 960-327   | Gas Engine (Kohler 6.5)      |                          | 1  |
| 39    | 710-693   | Hex Head Bolt                | ZP, M8*40                | 4  |
| 40    | 750-638   | Flat Washer                  | ZP, M8                   | 8  |
| 41    | 960-429   | Vibration Isolator 22/28 Ton | Ø24*Ø9*3                 | 4  |
| 42    | 720-500   | Lock Nut                     | ZP, M8                   | 4  |
| 43    | 540-911   | Reservoir Tank               |                          | 1  |
| 44    | 540-328   | Vented Dipstick              | Ø4*83                    | 1  |
| 45    | 730--655  | O Seal Ring                  | Ø15*3.1                  | 2  |
| 46    | 710-877   | Oil Drain Screw              | PH, M16*15               | 1  |
| 47    | 730-064   | O Seal Ring                  | Ø20*2.4                  | 1  |
| 48.1  | 540-074   | Suction filter               | Straight, Adapter, Hex32 | 1  |
| 48.2  | 730-602   | O Seal Ring                  | Ø28*3.1                  | 1  |
| 49    | 760-377   | Hose Clamp                   | 1"                       | 2  |
| 50    | 560-315   | Oil Suction Hose             | Ø24*320                  | 1  |
| 51    | 330-674   | Fender Support               |                          | 2  |
| 52    | 710-661   | Hex Head Bolt                | ZP, M8*25 (8.8)          | 2  |
| 53    | 710-637   | Hex Head Bolt                | ZP, M8*20 (8.8)          | 6  |
| 54    | 750-699   | Flat Washer                  | ZP, Ø9* Ø24*1.5          | 2  |
| 55    | 750-638   | Flat Washer                  | ZP, M8                   | 14 |
| 56    | 720-500   | Lock Nut                     | ZP, M8                   | 8  |
| 57    | 330-612   | Fender                       |                          | 2  |
| 58    | 330-524   | Wheel                        | Pneumatic, 16*4.8*8 in.  | 2  |
| 59    | 720-836   | Castle Nut                   | ZP, 1-14                 | 2  |
| 60    | 760-744   | Split Pin                    | ZP, Ø4*50                | 2  |
| 61    | 330-631   | Dust Cap                     |                          | 2  |
| 62    | 320-455   | Wheeled Trailer Jack         |                          | 1  |
| 63    | 710-333   | U-bolt                       | ZP, M10 x 190            | 1  |
| 64    | 320-457   | Jack Clamp 13 Ton            | W26                      | 2  |
|       | 320-459   | Jack Clamp 16 Ton            | W35.5                    |    |
| 65    | 710-669   | Hex Head Bolt                | ZP, M10*130 (8.8)        | 2  |
| 66    | 750-525   | Flat Washer                  | ZP, M10                  | 6  |
| 67    | 720-120   | Lock Nut                     | ZP, M10                  | 4  |
| 68    | 320-431   | Tongue                       |                          | 1  |
| 69    | 320-437   | Hitch Coupler                | 2"*3"                    | 1  |
| 70    | 320-421   | Safety Chain                 |                          | 2  |
| 71    | 710-622   | Hex Head Bolt                | ZP, M12*100 (8.8)        | 2  |
| 72    | 750-621   | Flat Washer                  | ZP, M12                  | 4  |
| 73    | 720-536   | Lock Nut                     | ZP, M12                  | 2  |
| 74    | 320-913   | Log Tray                     |                          | 2  |
| 75    | 710-895   | Inner Hex Head Bolt          | Black Oxide, M8*20       | 8  |
| 76    | 750-075   | Spring Washer                | Black Oxide, M8          | 8  |
| 77    | 750-160   | Flat Washer                  | Black Oxide, M8          | 8  |

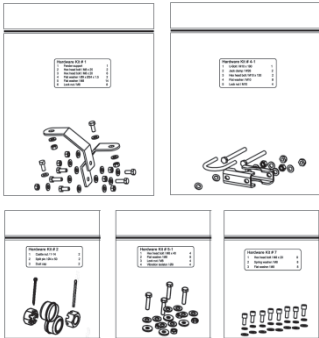
# PACKING LIST

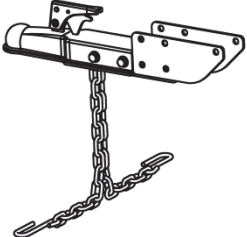
|   |  |   |
|---|--|---|
|    |   |   |
| <p>Beam assembly x 1</p>  | <p>Wheeled trailer jack assembly x 1</p>   |   |
|    |    |   |
| <p>Reservoir tank assembly x 1</p>  | <p>Engine / Pump assembly x 1</p>  |   |
|   |    |   |
| <p>Log tray &amp; Log dislodger assembly x 2</p>                                    | <p>Hardware kits box x 1, including:</p>   |   |
|  |    |  |
| <p>Fender x 2</p>   | <p>Control handle lever x 1</p>  | <p>Engine manual x 1</p>  |
|  |    |   |
| <p>Wheel x 2</p>  |   |   |
|  | <p>ASSEMBLY &amp; OPERATING INSTRUCTIONS</p> <p>MODEL NO. G013T21 / G016T21</p> <p>Owner's Manual</p> <p>Purchase Date: _____ Model NO: _____ Serial NO: _____</p> <p>Distributor: _____</p> <p>Booss Industrial, Inc. 123 Ambassador Drive, Suite 123, Naperville, IL 60563 USA<br/>Phone: (800) 780-8005 (24/7) Fax (331) 472-2876</p> |   |
| <p>Tongue assembly x 1</p>  | <p>Hardware kit #1, 2, 4, 5, 7</p>   | <p>Instruction manual x 1</p>   |