

# FEATURES AND BENEFITS

## KEY PARTS AND COMPONENTS

**A INVERTER DIRECT DRIVE MOTOR**  
The inverter motor directly connected to the tub produces less noise and vibration while offering outstanding durability with a longer lifespan.

**B ULTRA CAPACITY & NEVERUST™ STAINLESS STEEL TUB**  
The efficient design provides you with ultra large capacity.

**C TURBOWASH™**  
TurboWash™ reduces wash time without compromising performance. The precise drum movements and powerful water jets allow faster soaking, while the Smart Rinse™ Jet Spray allows quicker rinsing, saving you up to 30 minutes per load without sacrificing washing performance.

**D ALLERGIENE™**  
This powerful, high-temperature steam cycle is designed to reduce up to 95 percent of common household allergens such as dust mites and pet dander, and is certified by the Asthma and Allergy Foundation of America (AAFA).

**E REAR TOUCH PANEL**  
The easy to read LED display shows cycle options, setting, cycle status and estimated time remaining. The touch buttons offer more convenience and a premium design aesthetic.

**F SLAM PROOF™ LID**  
The Slam Proof™ lid is a safety device that closes the lid slowly. The Slam Proof™ hinges allow the lid to close gently and quietly, helping prevent injuries.

**G SMART DIAGNOSIS™**  
If you ever experience an issue with your LG washer, you don't have to worry. The SmartDiagnosis™ feature helps the service center diagnose problems over the phone, or with a simple app on your smart phone, helping you minimize costly, inconvenient service calls.

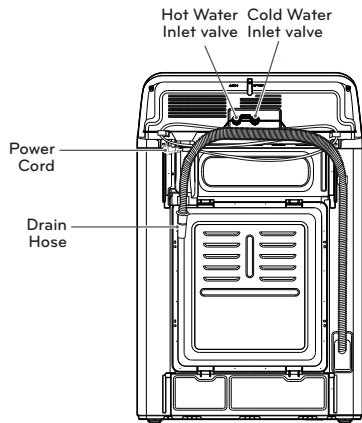
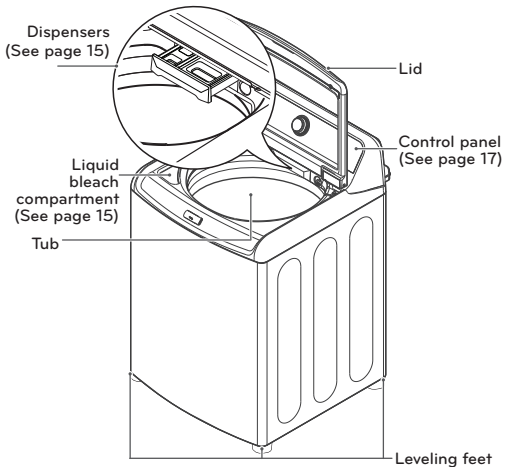

### INCLUDED ACCESSORY

- Tie Strap (for securing drain hose)



### REQUIRED ACCESSORY (sold separately)



Hot/cold water hoses

**Part Number**

- 5215FD3715U : Hot water hose
- 5215FD3715V : Cold water hose

• Required accessory is sold separately. It can be ordered through LG Website.  
US: [www.lg.com/us](http://www.lg.com/us)