GENERAL SAFETY PRECAUTIONS

WARNING: FAILURE TO READ AND FOLLOW THE SAFETY INSTRUCTIONS IN THIS OWNER'S MANUAL BEFORE INSTALLING OR USING YOUR ELECTRIC WINCH COULD RESULT IN DAMAGE TO YOUR WINCH AND SERIOUS OR FATAL INJURY!!

- ⚠ Check all safety and environmental conditions prior and during use.
- ⚠ Before use, ensure that you are familiar with all winching performance and operation such as speed & direction.
- ⚠ A wire rope should be replaced if it shows signs of excessive wear, broken wires, corrosion or any other defects.
- ⚠ The winches duty rating is S3 (intermittent – periodic)
- ⚠ If the winch fails to pull a load under normal conditions, stop the operation within 30 seconds otherwise motor damage may occur.
- ⚠ Ensure that the winch is connected to the correct voltage of 12VDC only.
- ⚠ Check that the freespool shifter is in the “Engaged” position during and after use.
- ⚠ Remove the remote control from the winch when not in use.
- ⚠ Do not wrap the wire rope around the load and back onto it self. Always use a strap to ensure that the wire rope does not fray or kink.
- ⚠ Keep hands and clothes away from the winch, wire rope, and fairlead during operation.
- ⚠ Never unplug the remote control and battery leads when winching a load.
- ⚠ To avoid insufficient power when winching a load, the vehicle should be running and in neutral.
- ⚠ When winching a heavy load, lay a heavy blanket or jacket over the wire rope near to the hook end
- ⚠ If excessive noise or vibration occurs when running, stop the winch immediately and return it for repair.

WARNING

- ⚠ The winch is rated for intermittent-periodic duty.
- ⚠ The winch is not to be used to lift, support or otherwise transport personnel.
- ⚠ A minimum of five (5) wraps of rope around the drum are necessary to support the rated load.
- ⚠ The rated line pull of the winch must be powerful enough to overcome the added resistance caused by whatever the vehicle is stuck in.
- ⚠ Never operate the winch under water.
- ⚠ Operate the winch cable in and cable out at no load after a winch was ingressed by water.

GENERAL SAFETY PRECAUTIONS

CAUTION



CUT AND BURN HAZARD

To avoid injury to hands and fingers:

- Always wear heavy leather gloves when handling a wire rope.
- Never let wire rope slip through your hands.
- Always be aware of possible hot surface at winch motor, drum or wire rope during or after winch use.

CAUTION

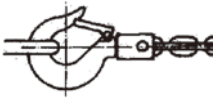

MOVING PARTS ENTANGLEMENT HAZARD

Moving Parts Entanglement Hazard

Failure to observe these instructions could lead to minor to moderate injury.

- Never apply load to hook tip or latch. Apply load only to the center of hook.
- Never use a hook whose throat opening has increased, or whose tip is bent or twisted.

WINCH SPECIFICATIONS DATAS:

Pulling Capacity	3,000 lbs (1363kgs)	Motor (12V)	1.5HP Series Wound
Gears	Split Ring	Gear Ratio	153:1
Control	Wired Wireless (Optional)	Clutch	Sliding Ring Gear
Cable (Dia.xl)	3/16" x 43ft.	Drum (Dia.xl)	1-1/4" x 2-7/8"
Braking	Automatic Inside	Mounting Pattern	3" Dia. x 4-7/8"

WINCH & ROLLER FAIRLEAD MOUNTING

1. It is very important that the winch shall be mounted on a flat hard surface in order to make sure the motor, drum and gearbox housing are aligned correctly.
2. If a different mounting plate is used, the thickness shall be 5 mm (3/16"). If different hardware is used, it must be grade 8 minimum.
3. Four (4) included M8x 25L Grade 8.8 High Tensile Steel Bolts must be used for securing the winch on the mounting plate in order to sustain the loads imposed on the winch mounting.
4. Two (2) included M8 x 20L Grade 8.8 High Tensile Steel Bolts must be used for securing the roller fairlead on the mounting plate.

WIRE CONNECTION

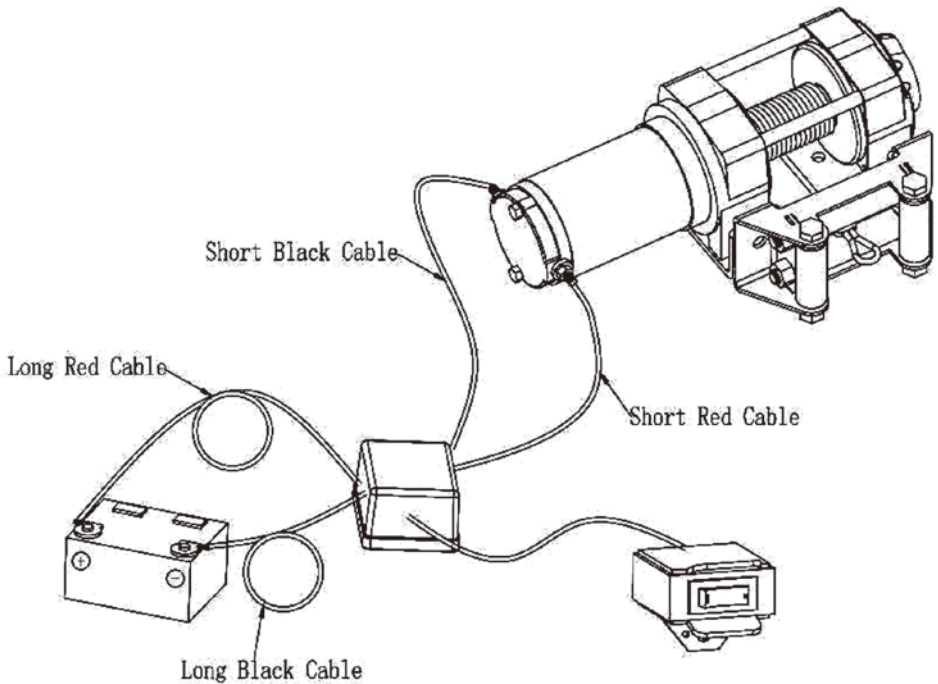

Long Red cable to Battery(+) Positive
Long Black cable to Battery(-) Negative
Short Red cable to Motor(+) Positive
Short Black cable to Motor(-) Negative

HANDLEBAR REMOTE CONTROL MOUNTING

Handlebar mounted trigger switch can be operated without removing your hand from the grip.

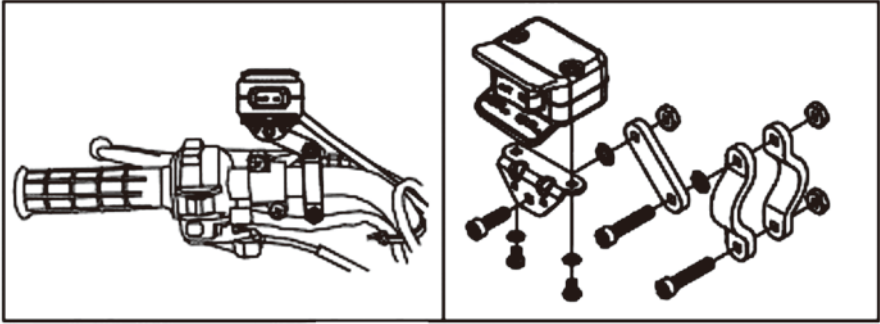

- It is recommended that the switch be installed on the left handlebar. A piece of electrical tape around the handlebar will help prevent rotation of mount on the handle bar.
- Do NOT tighten over any hoses or cables.

OPERATION

CABLE IN AND OUT

- 1). To determine “ Cable Out “, turn to the “Out” position
- 2). To determine “ Cable In “, turn to the “In” position
- 3). To stop winching, release the trigger level

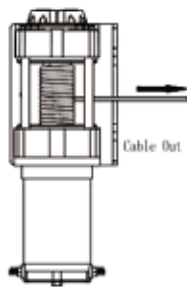
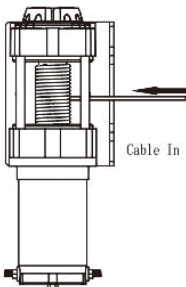

FREESPOOL FUNTION

The freespool allows rapid pay-out of the wire rope for hooking onto a load or anchor points and is operated by a freespool shifter located on the end of the winch.

- 1). To engage the freespool, turn the freespool shifter counter-clockwise to the “Engaged” position. The winch is now ready for pulling.
- 2). To disengage the freespool, turn the freespool shifter clockwise to the “Disengaged” position. Wire rope can now be free spooled off the drum.

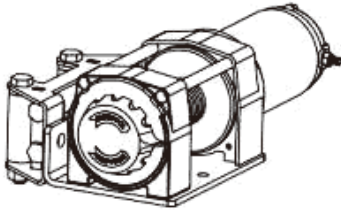

Freespool

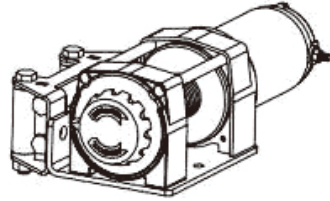

Engaged

MAINTENANCE

WIRE ROPE REPLACEMENT

Before installing a new wire rope, wrap the end of the wire rope with tape to prevent fraying. Wind the wire rope on the drum by pull a force to keep the tension constant. Never use a wire rope of a different size or material and only use aircraft grade wire ropes.

- 1). Disengage the freespool.
- 2). Spool the old wire rope, and then remove it from the drum.
- 3). Have horizontal roller and bolts apart from the roller fairlead, then place the replacement wire rope through the roller fairlead throat, pass below the drum, and insert it into the hole on the drum core.
- 4). Use a hex wrench to tighten the screw downwards to secure the wire rope.
- 5). Tighten the horizontal roller and bolt of roller fairlead
- 6). Wear leather gloves and use a strap when guiding the wire rope off the drum.



(Disengaged)

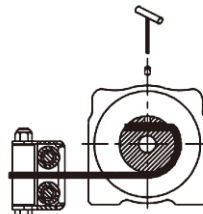

-
- 7). It is very important that the winch shall be mounted on a flat surface, with the wire rope feeding form the bottom of the drum.
 - 8). To rewind wire rope on the drum correctly , it is necessary to keep a slight load on the wire rope while cable in.

LUBRICATION

All moving parts in the winch are permanently lubricated at the time of assembly. Under normal conditions factory lubrication will suffice. If re-lubrication is necessary after repair or disassembly use a marine type grease.

CHECK THE SYSTEM

Before using the winch, verify the following:

- 1) Wiring to all components is correct. All loose wires are tie wrapped tight.
- 2) There are no exposed wiring or terminals. Cover any existing terminal exposures with terminal boots, heat shrink tubing or electricians tape.
- 3) Turn ATV key switch to ON position. Check winch for proper operation. The wire rope should spool in and out in the direction indicated on the switch.

KNOW YOUR WINCH

- Take time to fully understand your winch and the winching operation by reviewing the manual with your winch.