

RY141600 QUICK REFERENCE GUIDE

⚠ WARNING:

This Quick Reference Guide is not a substitute for reading the operator's manual. To reduce the risk of injury or death, user must read and understand operator's manual before using this product. All page references refer to the operator's manual.

FIRST TIME ASSEMBLY

1 Connect the spray wand to the trigger handle (see page 10).



2 Connect the high pressure hose to the trigger handle (see page 10).

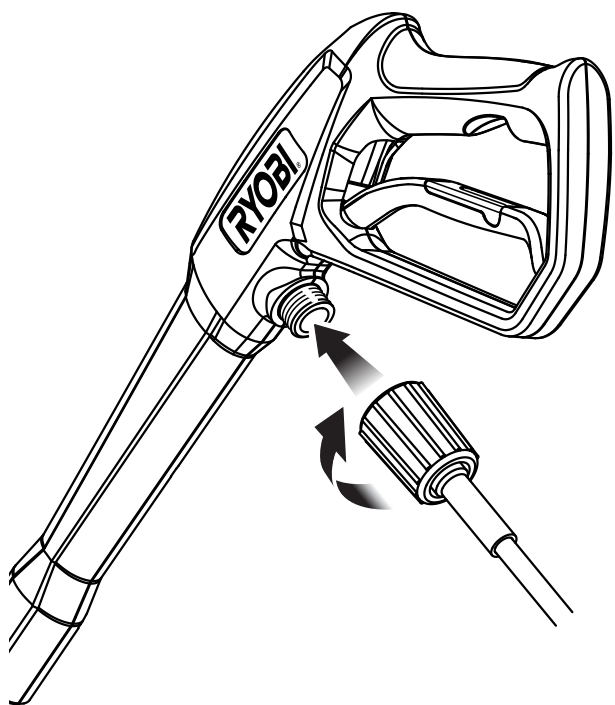

3 Connect the high pressure hose to the pump (see page 10).

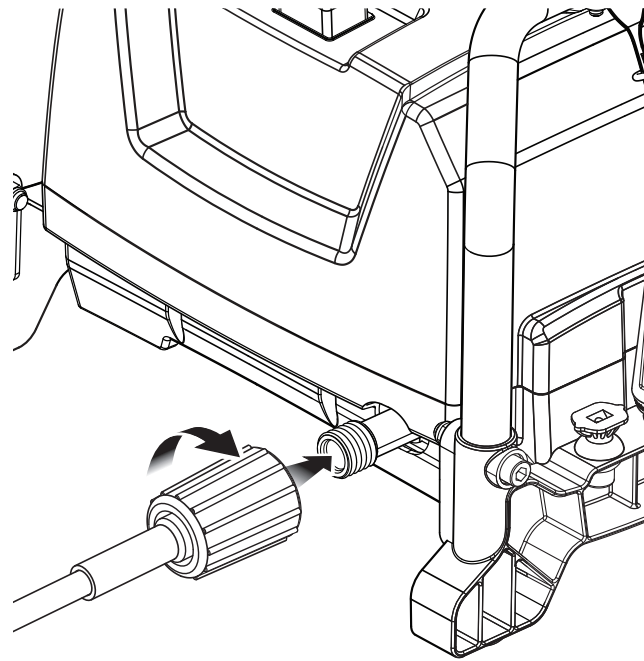

4 Connect the garden hose to the pump (see page 10).

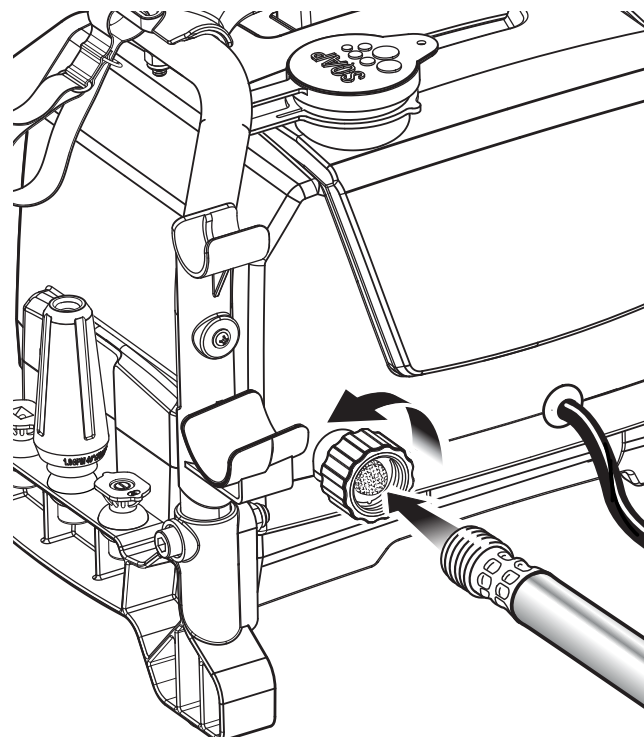

Completely uncoil garden hose or remove completely from reel to prevent kinks.

Turn water faucet on fully.

Make sure there are no leaks.

With no nozzle installed, squeeze the trigger to relieve air pressure. Hold the trigger until a steady stream of water appears.

STARTING THE UNIT

1 Connect the pressure washer to the power supply. Press the reset button on the plug to make sure the unit is ready for operation (see page 11).

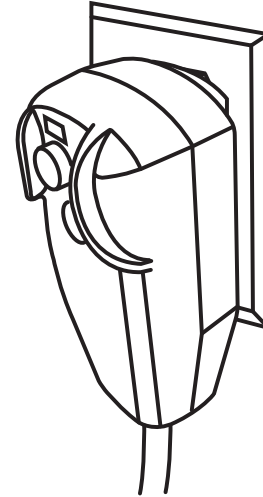

If using an extension cord, arrange a drip loop to avoid the possibility of the tool plug getting wet (see pages 3 and 8).

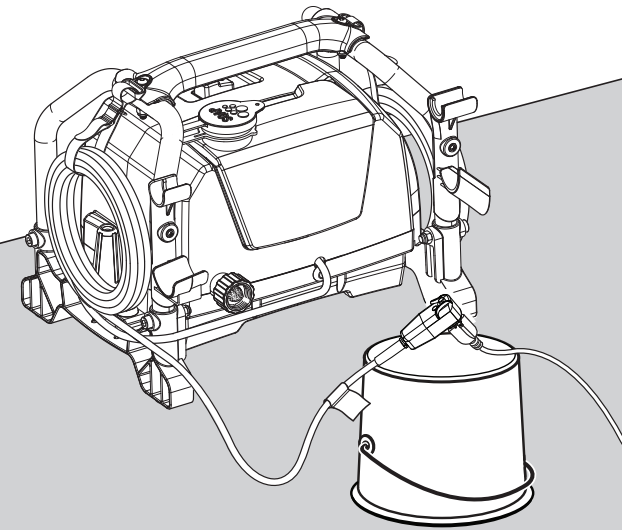

USE ONLY THIS SIZE EXTENSION CORD WHEN USING THIS PRODUCT:

Cord Length	Wire Size (A.W.G.)
25 ft.	14
50 ft.	12
100 ft.	Not Allowed

NOTE: A.W.G. = American Wire Gauge

2 Press switch ON to start the motor (see page 11).

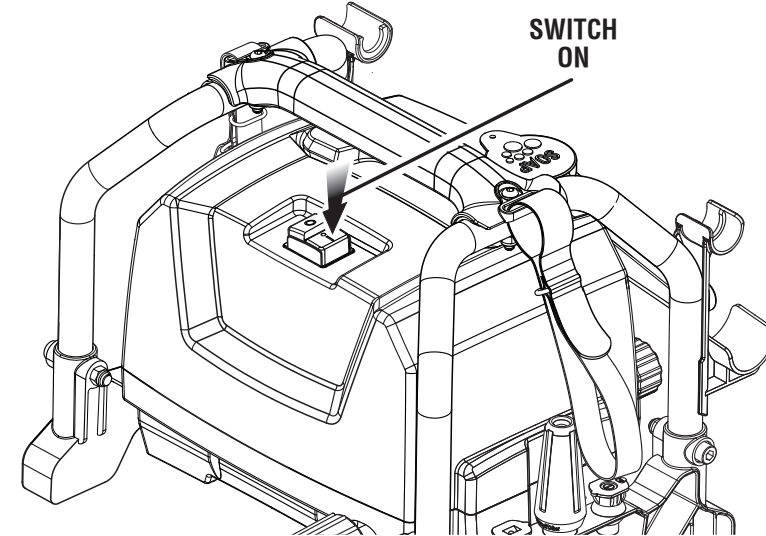

3 When finished, press switch OFF to stop the motor (see page 12).

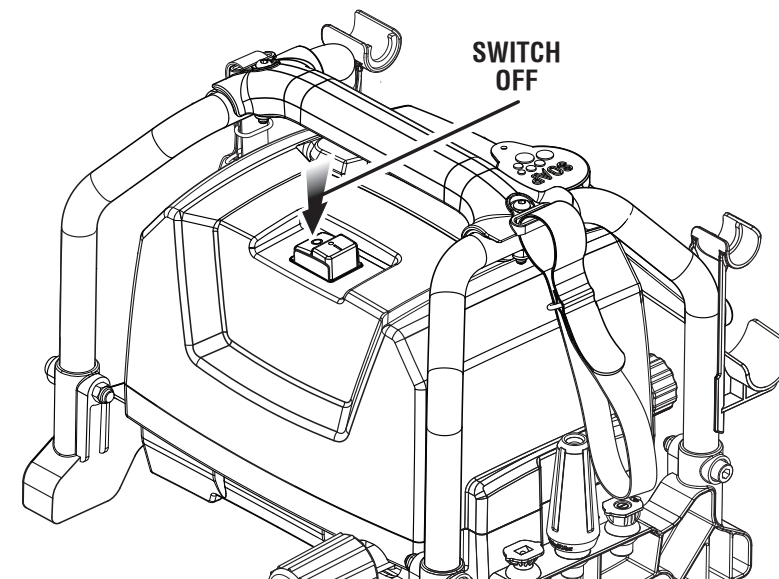

USING DETERGENT

1 Pour pressure washer detergent in soap tank (see page 13).

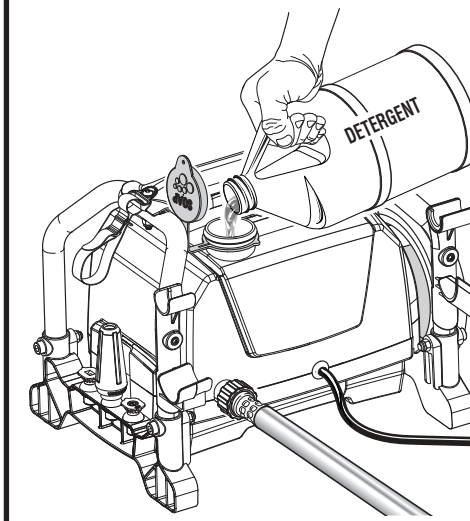

2 Install blue or black soap nozzle (see page 13).

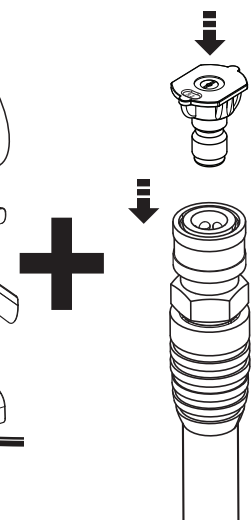

3 Squeeze trigger and wait approx. 5 seconds for soap (see page 13).

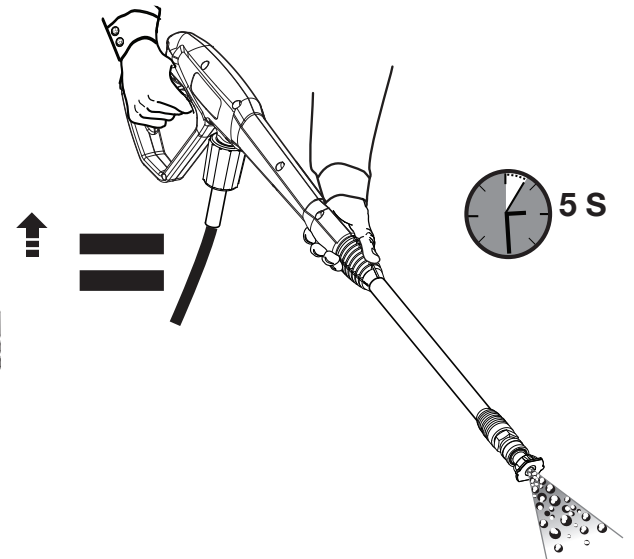

Use of soap nozzle will activate detergent injector at a 20:1 dilution ratio.

WARNING! Never use bleach or solvent-based detergent.

- Will damage your pump
- Will void your warranty
- Will damage plants/shrubs

NOZZLE SELECTION GUIDE

Use the chart below to determine the correct nozzle for your job.

TURBO NOZZLE 15° SOAP	HIGH PRESSURE (NO SOAP WHEN USING THESE NOZZLES)		LOW PRESSURE (FOR SOAP OR GENTLE RINSE)
	Turbo Nozzle	15°	Blue or Black Soap Nozzle
 ABRASIVE GENTLE			
Concrete, Brick, Masonry	✓	✓	✓
Siding, Gutters, House		✓	✓
Fencing, Deck, Patio		✓	✓
Lawn Equipment, Boat, RV		✓	✓
✓ Recommended Nozzle ✓ Use With Caution for Certain Applications			

BEFORE STORING THE UNIT

1 Always add Pump Protector to the unit after each use and before storing. This will significantly improve pump life. (See page 14.)

Pump protector is available from your local retailer. For further assistance, call customer service at 1-800-860-4050.

To add, follow the instructions provided by the Pump Protector manufacturer.



Make the most of your purchase! Go to www.ryobitools.com and register your new tool online. For questions about operating or maintaining your product please call, 1-800-860-4050.

RYOBI™