

16674-T



Call Us First!

DO NOT RETURN TO STORE.

For immediate help with assembly or product information
call our toll-free number:

1-888-827-9056

or email:

customerservice@backyardproductsllc.com

Our staff is ready to provide assistance.

April through October M - F 8:00 AM to 7:00 PM EST

Saturday 8:30 AM to 4:30 PM EST

November through March M - F 8:00 AM to 5:00 PM EST

ANTES DE DEVOLVERLO, ¡LLÁMENOS!

Si desea más información sobre el montaje, llámenos sin coste
adicional alguno al siguiente teléfono:

+1-888-827-9056

o correo electrónico:

customerservice@backyardproductsllc.com

Nuestro personal le proporcionará toda la ayuda que necesite.

Abril por octubre M - F 8:00 EST a 7:00 P.M. EST

el sábado 8:30 EST a 4:30 P.M. EST

noviembre por marzo M - F 8:00 EST a 5:00 P.M. EST

(This page intentionally left blank.)

(Esta página está intencionado en blanco.)

Customer Service
(Servicio al cliente)
1-888-827-9056
1000 Ternes Drive
Monroe, MI 48162

Heritage / Signature Series

8' Wide Saltbox

Techo a dos aguas 8'

Includes 8'x12' (244x367 cm), 8'x16' (244x488 cm)
Building Instructions

Instrucciones para edificios de
8'x12' (244x367cm), 8'x16' (244x488 cm)

Tools required (Herramientas necesarias)

- Hammer
(martillo)
- Phillips Screw-
driver
(Desarmador cruz)
- Level
(Nivel)
- Ladder
(escalera)
- Pencil
(lápiz)
- Tape Measure
(Cinta métrica)
- Utility Knife
(Navaja)
- Paint Tools
(Herramientas
para pintar)
- Caulk Gun
(pistola para ma-
sillado)
- Hand Saw
(Sierra portátil)
- Wood Glue
(Pegamento para
madera)

Optional Tools (Herramientas opcionales)

- Electric Drill w/
#2 Phillips Tip
(Taladro eléctrico
Broca "Phillips")
- Chalk Line
(Linea de marcar)
- Square
(Escuadra)
- Nail Pouch
(Bolsillo para
clavos)

- BEFORE YOU BEGIN -

First...

- Check with your local building authority before erecting.
- Read instructions thoroughly before you begin.

Building Codes

- Our buildings are designed to meet most local and national U.S. codes and are not meant to be used for living space.
- General construction drawings can be provided.
- Stamped certified drawings can be provided for a fee. Call for details.

Check All Parts

- If a part is missing, circle the part in question and call.
- Please note the primer color may vary on siding and trim parts. This is a factory applied primer intended for preparing your building for painting. This is NOT a finish coat. This primer color variation will not affect the look of your building once painted.

Important

- Lumber is graded from one side, use most attractive face to the outside.
- In a drawing, a dotted line represents a part hidden from view (like a part under a panel).

Assistance required

- Assistance is necessary to handle, fit, and secure some components.

Squareness is very Important!

- Keep 90° corners and 90° perpendiculars throughout the assembly to ensure all components fit together.

Check foundation size

- Before starting on your foundation, make sure you are building the correct size foundation for your building.

Always wear OSHA-APPROVED safety glasses throughout assembly process

- ANTES DE EMPEZAR -

Primero...

- Consulte la autoridad de construcción local antes de construir el edificio.
- Lea las instrucciones completamente antes de empezar.

Códigos de Construcción

- Hemos diseñado nuestros edificios a que conformen con todos los códigos de construcción locales y nacionales. Los edificios no están proyectados como residencia.
- Se disponen planes generales de construcción.
- Se disponen de planes certificados por un precio. Estos planes no garantizan la aprobación de los autoridades locales.

Compruebe todas las piezas

- Si falta una pieza, indícala con un círculo y llámenos.
- Aviso: El color del imprimador puede variar en la cobertura y las partes de la moldura. Este imprimador se aplica en la fábrica y es para preparar su edificio para pintar. NO es una capa de pintura terminada. La variación en el color del imprimador no afectará la apariencia de su edificio al pintarlo.

Importante

- La Madera está elaborada en un solo lado. Use el lado más atractivo en el exterior.
- Si falta una pieza, póngale un círculo y llámenos.
- En un dibujo una línea punteada representa una pieza no vista (por ejemplo, una pieza debajo de un panel)

Ayuda requerido

- Seleccione un sitio nivelado.
- Será necesario pedir ayuda para manejar, unir, y reforzar algunas piezas.

¡Es preciso escuadrar el edificio!

- Mantenga ángulos de 90° en las esquinas y los perpendiculares durante la construcción para asegurar que todas las piezas se unen correctamente.

Compruebe las dimensiones de la cimentación.

- Compruebe que las dimensiones de la cimentación son las correctas para el edificio.

Siempre lleve gafas de seguridad aprobadas por OSHA durante la construcción.

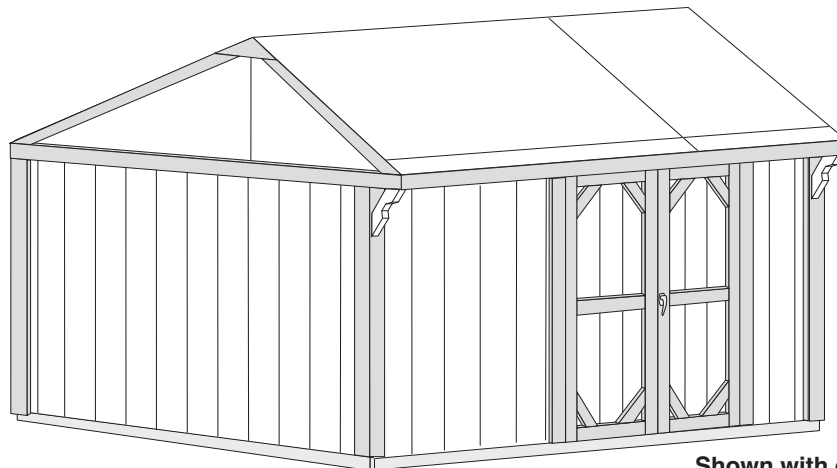

Shown with extenders











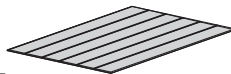
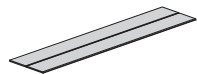
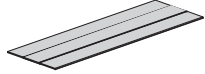
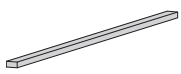
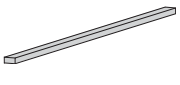
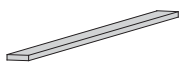
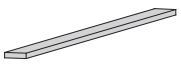
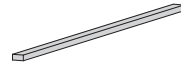
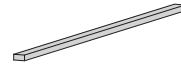
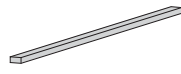

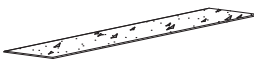

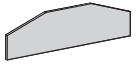

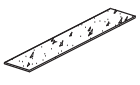

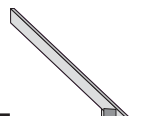
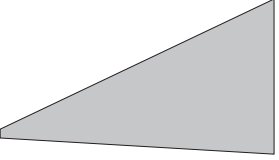
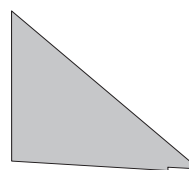
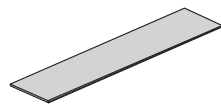
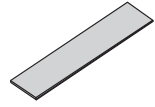

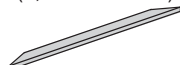
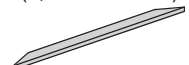

Demostrado con Extensiones

We manufacture kits from select construction grade lumber and engineered wood products. Construction grade lumber, a product cut from trees, has many natural characteristics and blemishes that may be present in some of the pieces you receive in your kit. Natural characteristics and blemishes in construction lumber may include knots, torn wood grain along edges, minor cracks/splits, twists, limited bark along edges and pitch pockets that may exude sap. Be assured that the individual parts have been cut and inspected to remove as many of the wood's natural, less appealing characteristics as possible. These characteristics and/or blemishes will not affect the strength, durability, or structural integrity of the finished product. Generally, the exterior trim parts selected for your kit are graded from only one side and should be installed with the most attractive side outward. Our limited warranty does not cover the natural characteristics and blemishes that occur with construction grade lumber products.

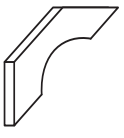
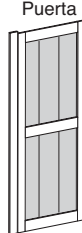
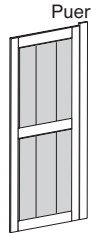
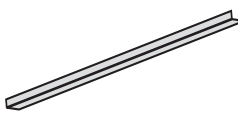
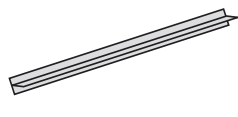
Fabricamos nuestros equipos de madera elaborada y de productos maquinados de madera. La madera elaborada, producto de árboles, tiene muchas características e imperfecciones naturales que puedan tener algunas piezas contenidas en el equipo. Estas imperfecciones y características pueden incluir nudos, grano rasgado sobre el borde, rajaduras/grietas pequeñas, torsiones, cortezas en el borde, y bolsos que exuden savia. Aseguramos que hemos cortado e inspeccionado las partes individuales para eliminar las características naturales menos atractivas posibles. Estas características y/o imperfecciones no afectarán la fuerza, durabilidad ni la integridad estructural del producto final. Por lo general, las piezas de moldura exterior seleccionadas para su equipo se elaboran de un solo lado y deben ser instaladas con la parte más atractiva por fuera. Nuestra garantía limitada no cubre las características e imperfecciones que ocurren con los productos de madera elaborada.

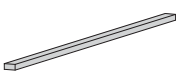
8' X 12' (244 x 366 cm)
PARTS LIST











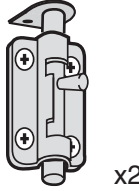
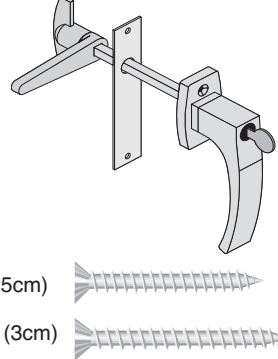

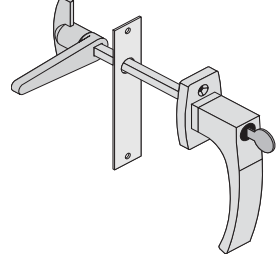
8' X 12' (244 x 366 cm)
LISTA DE PIEZAS

MURO	A 3/8"x48"x72" (.9x122x183 cm)  x7	B 3/8"x15-7/8"x72" (.9x40x183 cm)  x2	C 3/8"x23-7/8"x72" (.9x61x183 cm)  x2	SP 2"x4"x48" (5x10x122 cm)  x4	UM 2x4x68" (173 cm)  x23
	VK 2x6x92-1/2" (235 cm)  x2	VF 2x6x48" (122 cm)  x2	TJ 2x4x92-1/2" (235 cm)  x8	UN 2x4x94-1/2" (240 cm)  x2	RL 2x4x24" (61 cm)  x2
TECHCO	E 7/16"x48"x96" (1.1x122x244 cm)  x2	F 7/16"x47-7/8"x48" (1.1x122x122 cm)  x2	G 7/16"x4"x96" (1.1x10x244 cm)  x1	JF 1x4x60" (2.5x10x153 cm)  x5	Q Gusset Placa de unión  x12
	L 7/16"x23"x96" (1.1x59x244 cm)  x1	H 7/16"x23"x48" (1.1x61x122 cm)  x1	M 7/16"x4"x48" (1.1x10x122 cm)  x1	QG Rafter  x7	QF Viga  x7
ROOF	R 3/8"x3-1/8x64-7/8x30-13/16" (0.9x7.9x165x78 cm)  x2	S 3/8"x1-7/8x34-3/4x30-7/8" (0.9x4.6x88x78 cm)  x2	N 3/8"x9-3/16"x96" (0.95x23x244 cm)  x1	O 3/8"x9-3/16"x24-3/8" (0.95x23x63cm)  x2	
	YX 5/8"x4"x38-5/8" (1,6x10x99 cm)  x2	ZJL 5/8"x4"x41-3/4" (1,6x10x106 cm)  x1	ZJR 5/8"x4"x41-3/4" (1,6x10x106 cm)  x1	ZKL 5/8"x4"x56-1/2" (1,6x10x144 cm)  x1	ZKR 5/8"x4"x56-1/2" (1,6x10x144 cm)  x1
MOLDURA	ZO 5/8"x4"x72" (1,6x10x182 cm)  x4	ZP 5/8"x4"x72-3/8" (1,6x10x183 cm)  x6	ZJ 5/8"x3"x72" (1,6x7,6x182 cm)  x4	T 5/8"x5-7/8"x24" (1,6x15x61 cm) 1 Right / 1Left 1 Derecha / 1 izquierda  x2	Z Corbels  x2
	V Left Door Puerta izquierda  x1	W Right Door Puerta derecha  x1	DEL 68-1/2" Metal Door Edge "L"  x2	DWS 68-1/2" Weatherstrip  x1	P Metal Threshold Entrada de Metal  x1
TRIM	X 5/8"x3"x72" (1.6x7.6x183x cm)  x1	UP 2"x4"x68-1/2" (5x10x173 cm)  x2	ZWL 5/8"x4"x35-1/4" (1,6x10x90 cm)  x2	ZWR 5/8"x4"x35-1/4" (1,6x10x90 cm)  x2	Y 5/8"x4"x14" (1,6x10x36 cm)  x8
	DOOR				

**8' X 12' (244 x 366 cm)
PARTS LIST**

**8' X 12' (244 x 366 cm)
LISTA DE PIEZAS**

HARDWARE | FERRETERÍA

		Actual Size	Dimensiones Verdadera
 x2	 x2	3" (7.6 cm)	 x 301
		2" (5.0 cm)	 x 747
 1" (2.5cm)  x2 1-1/4" (3cm)  x2		2" (5.0 cm)	 x 238
		1-1/2" (3.8 cm)	 x 212
		3" (7.6 cm) ⊕	 x 20
		2" (5 cm) ⊕	 x 12
		1-5/8" (4.1 cm) ⊕	 x 10
		1" (2.5 cm) ⊕	 x 28
		1" (2.5 cm) ⊕	 x 34
		3/4" (19 mm) ⊕	 x 43

Lumber Sizes Nominal Size (Dimensión nominal)	Dimensiones de la madera Actual Size (Dimensiones verdaderas)
1 x 4 =	3/4" x 3-1/2" (1.9 x 8.9 cm)
2 x 4 =	1-1/2" x 3-1/2" (3.8 x 8.9 cm)
2 x 6 =	1-1/2" x 5-1/2" (3.8 x 14 cm)

Note
Double and Triple Letter Part identification letters are stamped on part and read horizontally, single letter part letters not stamped on parts.

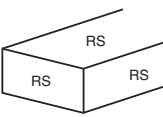



Aviso
Dos letras o tres letras de identificación están marcadas horizontalmente en las piezas. Letras de identificación de una sola letra no están en las piezas.

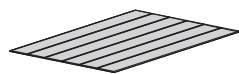
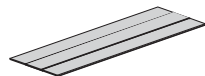

**8' X 4' (244 x 122 cm)
EXTENDER PARTS LIST**

**8' X 4' (244 x 122 cm)
LISTA DE PIEZAS DE EXTENSIÓN**

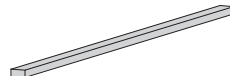
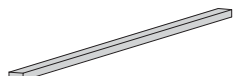
WALL | MURO

3/8"x48"x72" (.9x122x183 cm)  A x1	3/8"x23-7/8"x72" (.9x61x183 cm)  C x2	2x6x48" (5x15x122 cm)  VF x2	2x4x68" (5x10x173 cm)  UM x4	2x4x48" (5x10x122 cm)  SP x4
---	--	---	---	---



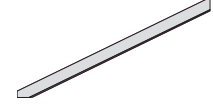
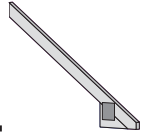

ROOF | TECHO

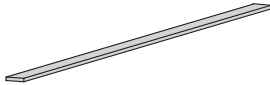
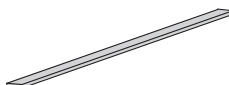
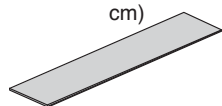
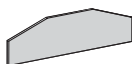
7/16"x47-7/8"x48" (1.1x122x122 cm)  J x2	7/16"x4"x48" (1.1x10x122 cm)  G x1	7/16"x23"x48" (1.1x58x122 cm)  K x1	Rafter  QG x2	Viga  QF x2
---	---	--	--	---

**MOLDURA
TRIM**

5/8"x4"x48" (1,6x10x122 cm)  ZT x2	1x4x60" (2.5X10X152 cm)  JF x2	3/8"x9-3/16"x47-7/8" (0.95x23x122 cm)  I x1	Gusset  Q x4
---	---	---	--

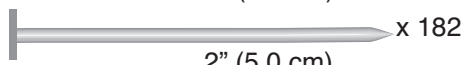
HARDWARE | FERRETERÍA

Actual Size	Dimensiones Verdadera
 x 56 3" (7.6 cm)	 x 12 2" (5.0 cm)
 x 182 2" (5.0 cm)	 x 48 1-1/2" (3.8 cm)

IMPORTANT!!!

Building Tip

IMPORTANTE!!!

Consejo

FOR THE BEST LOOKING FINISHED PRODUCT WE RECOMMEND THAT YOU INSPECT, SORT AND LAY OUT MATERIALS PRIOR TO BEGINNING ASSEMBLY OF YOUR BUILDING

CON EL FIN DE OBTENER EL PRODUCTO ACABADO DE MEJOR ASPECTO RECOMENDAMOS QUE INSPECCIONE, CLASIFIQUE Y ORGANICE LOS MATERIALES ANTES DE EMPEZAR A MONTAR SU EDIFICIO

HELPFUL MATERIAL NOTICE

AVISO ÚTIL SOBRE LOS MATERIALES

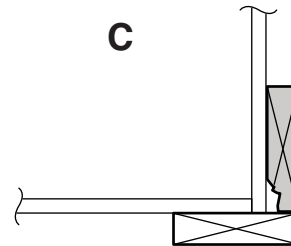
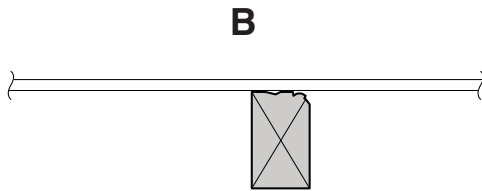
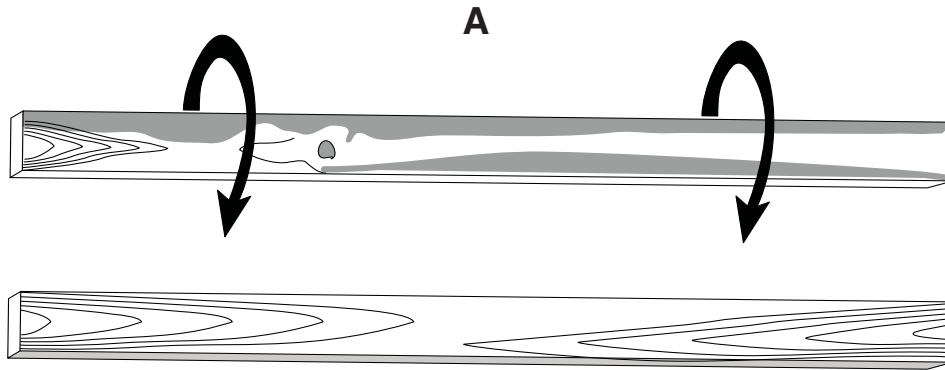

Wood is a natural product that has inherent blemishes. All interior framing is graded for structural strength and not appearance. Exterior trim is graded for one good side per industry standards.

- Blemishes can be easily installed to provide the best appearance. (Fig. A)
- Install wall framing with any blemished sides toward the siding and facing rear of building. (Fig. B)
- Install corner trim, gable trim and fascia with any blemished sides toward the siding material. (Fig. C)

Always install the material leaving the best edge and best surface visible.

Please remember that these blemishes in no way negatively affect the strength or integrity of our product.

La madera es un producto natural que tiene defectos inherentes. Todo la estructura interior ha sido aprobada por ofrecer una resistencia estructural y no por su aspecto. La guarnición exterior ha sido aprobada por tener un buen lado según las normas de la industria.

- La parte con defectos puede instalarse fácilmente de modo que el edificio tenga el mejor aspecto. (Fig. A)
- Instale el entramado de la pared con los lados con defectos apuntando hacia los costados y haciendo frente a la parte trasera del edificio. (Fig. B)
- Instale la guarnición de las esquinas, la guarnición de los hastiales y las impostas con los lados con defectos apuntando hacia el material lateral. (Fig. C)

Instale siempre el material dejando visibles el mejor borde y la mejor superficie.

Recuerde que estos defectos no afectan de forma negativa la resistencia o la integridad de nuestros productos.

Please feel free to call our Consumer Help Line - Toll Free
1-888-827-9056

April through October M - F 8:00 AM to 7:00 PM EST

Saturday 8:30 AM to 4:30 PM EST

November through March M - F 8:00 AM to 5:00 PM EST

Llame de forma gratuita a nuestra línea de ayuda al consumidor

1-888-827-9056

Abril por octubre M - F 8:00 EST a 7:00 P.M. EST

el sábado 8:30 EST a 4:30 P.M. EST

noviembre por marzo M - F 8:00 EST a 5:00 P.M. EST

FOUNDATION OPTIONS

(Not supplied with kit)

YOU MUST ASSEMBLE YOUR BUILDING ON A WOOD FLOOR OR CONCRETE SLAB.

SITE PREPARATION

- Site must be properly leveled.
- Site should have natural drainage and no standing water

OPCIONES PARA LA CIMENTACIÓN

(No incluidas)

HAY QUE CONSTRUIR EL EDIFICIO SOBRE UN BASE DE MADERA O DE CONCRETO.

PREPARACIÓN DEL SITIO

- El sitio debe de estar nivelado correctamente.
- Instale una barrera contra yerbajos debajo de la estructura.

A) Purchase our optional Floor Kit or build your own wood floor.

A) Compre nuestro equipo opcional para el suelo o construya su propio suelo de madera.

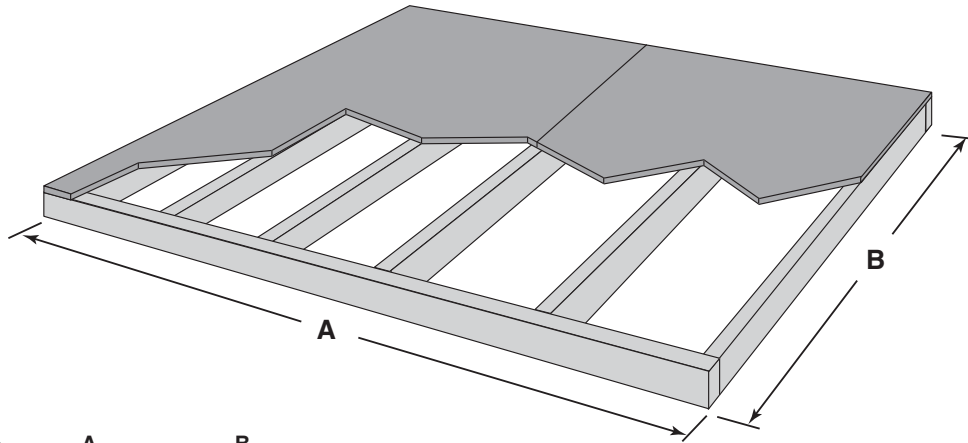

Building Size Dimensiones del edificio	A	B
8' x 12' (244 x 366 cm)	96" (244 cm)	144" (366 cm)
8' x 16' (244 x 488 cm)	96" (244 cm)	192" (488 cm)

Important: Square floor and level to ground before beginning assembly of building.

Importante: Asegure que el suelo está nivelado y escuadrado antes de construir el edificio.

B) Concrete Slab Foundation

B) Base en losa de concreto

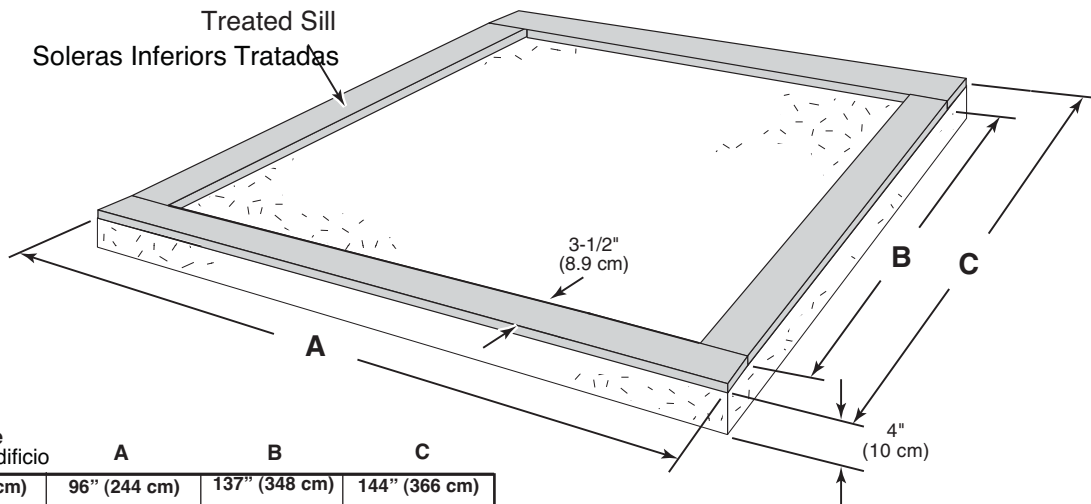

Building Size Dimensiones del edificio	A	B	C
8' x 12' (244 x 366 cm)	96" (244 cm)	137" (348 cm)	144" (366 cm)
8' x 16' (244 x 488 cm)	96" (244 cm)	185" (470 cm)	192" (488 cm)

Fasten treated 2x4 sill plates to slab using approved concrete anchors. (Treated sill plates and fasteners not included.)

Fije las soleras inferiores tratadas de tamaño 2x4 a la losa usando anclajes de concreto aprobados. (Las soleras y los anclajes no están incluidos.)



STOP Before proceeding, determine desired door location and build door wall first.



STOP Antes de continuar determine la posición de la puerta y construya el muro con la puerta primero.

**BUILD WALL
NUMBERS SPECIFIED
WALL NUMBER EQUALS
PAGE NUMBER**

**CONSTRUYA LOS NÚMEROS DE
LOS MUROS ESPECIFICADOS.
EL NUMERO DEL MURO CORRESPONDE
AL NUMERO DE LA PAGINA.**

8' X 12' (244x366 cm)

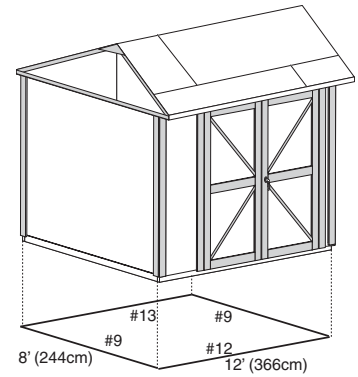
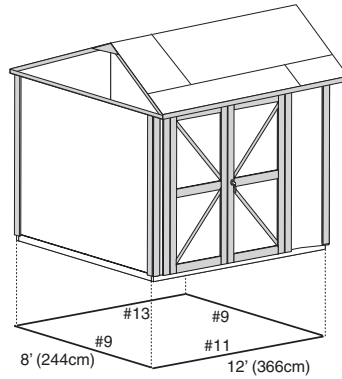
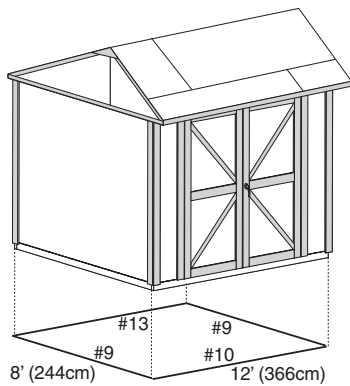

8' X 16' (244x488 cm)

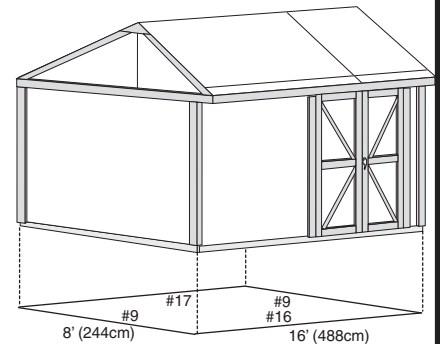
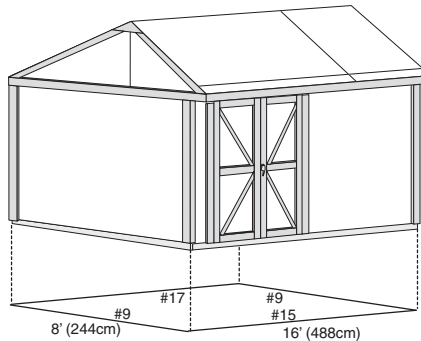
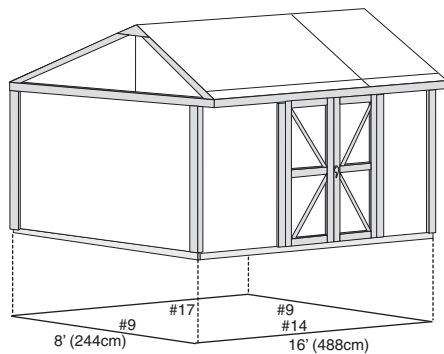

IMPORTANT!!!

Building Tip

YOUR BUILDING CAN BE CONFIGURED IN A VARIETY OF WAYS. BEFORE ERECTING WALLS, REFER TO PAGE 5 TO ENSURE YOU BUILT THE RIGHT WALLS FOR YOUR BUILDING.

IMPORTANTE!!!

Consejo

ES PRECISO ALINEAR LOS PANELES DE LOS MUROS Y DEL TECHO ANTES DE CLAVARLOS COMPLETAMENTE PARA ASEGURAR LA ESCUADRA.

Erecting the Walls

Make sure all walls are built as shown below.
BUILD DOOR WALL FIRST.

Construyendo los Muros

Asegure que se construyan los muros como en los dibujos abajo.
CONSTRUYA EL MURO CON PUERTA PRIMERO.

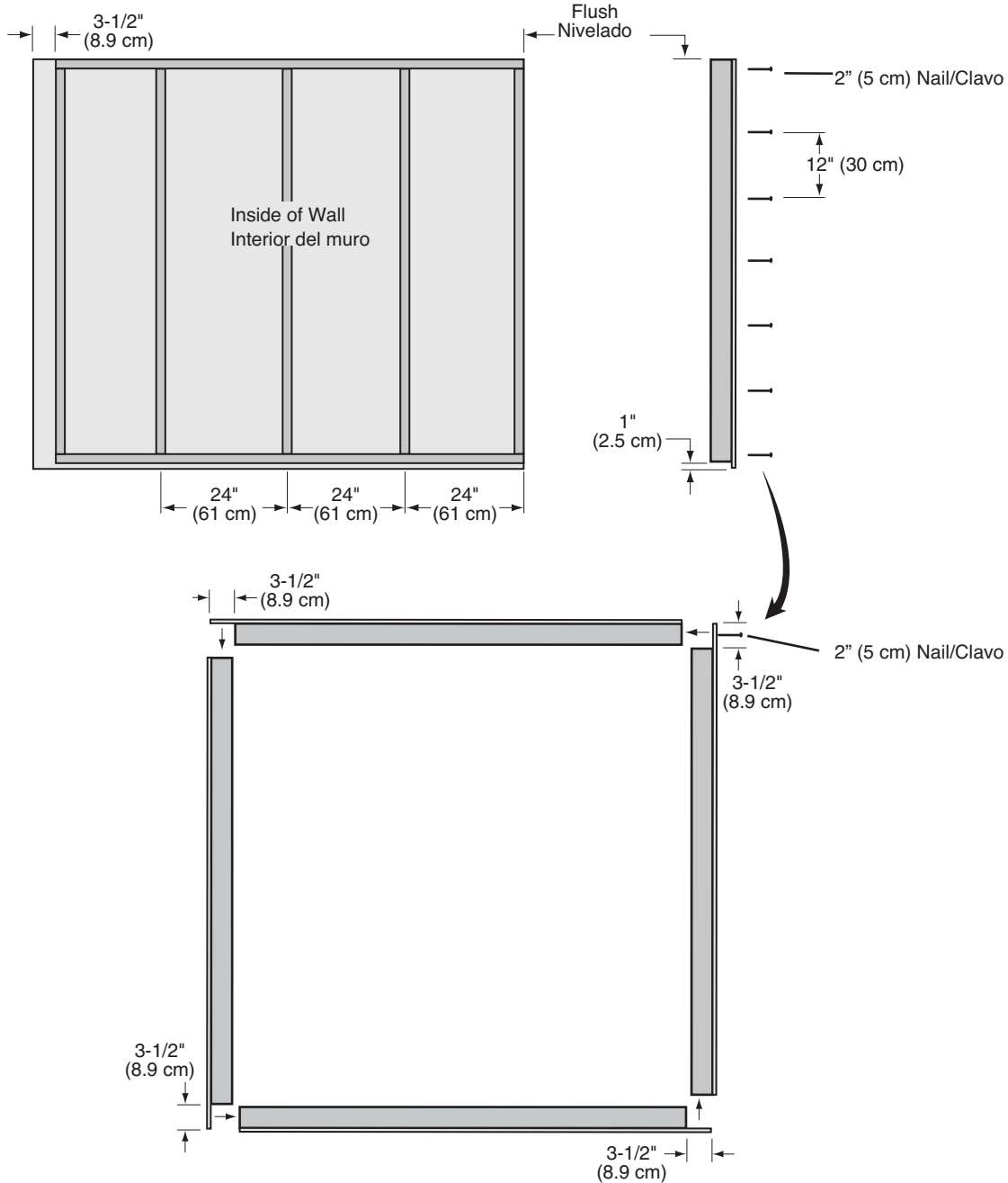

IMPORTANT!!!

Building Tip

YOU MAY NEED TO RACK YOUR WALL PANELS AND ROOF PANELS TO ENSURE SQUARENESS BEFORE COMPLETELY NAILING

IMPORTANTE!!!

Consejo

ES PRECISO ALINEAR LOS PANELES DE LOS MUROS Y DEL TECHO ANTES DE CLAVARLOS COMPLETAMENTE PARA ASEGURAR LA ESQUADRA.

Racking a Wall

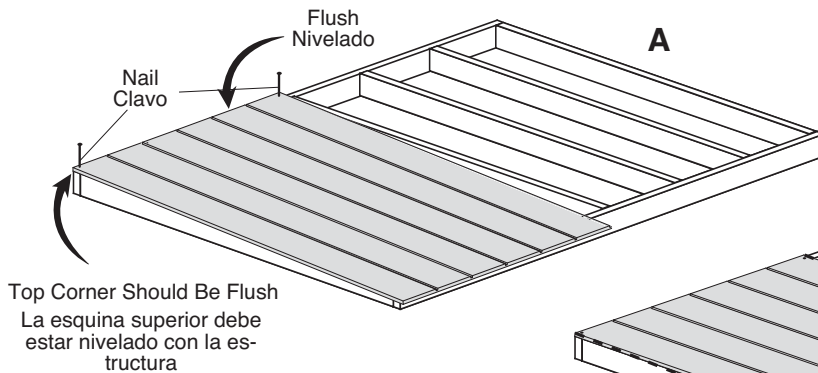

Alineando un Muro

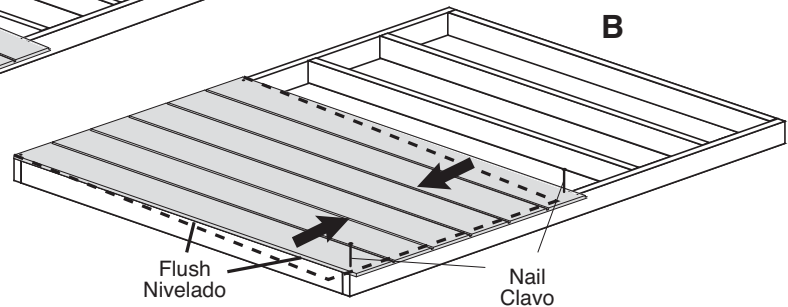

When building walls, always apply panel at far left first. Position panel flush with top of wall frame and nail in upper corners as shown. Rack wall square by moving lower end of wall panel right or left until panel is flush with framing along left edge and secure with one nail in each lower corner. Continue nailing as instructed.

Al construir los muros, siempre fije primero el panel hasta la izquierda extrema. Posicione el panel nivelado con la parte superior de la estructura del muro y clávelo en la esquina superior como en el dibujo. Alinee nivelado el muro por mover el lado inferior a la derecha o a la izquierda hasta que el panel esté nivelado con la estructura a lo largo del borde izquierda. Fije con un clavo en cada esquina inferior.

Racking a Roof

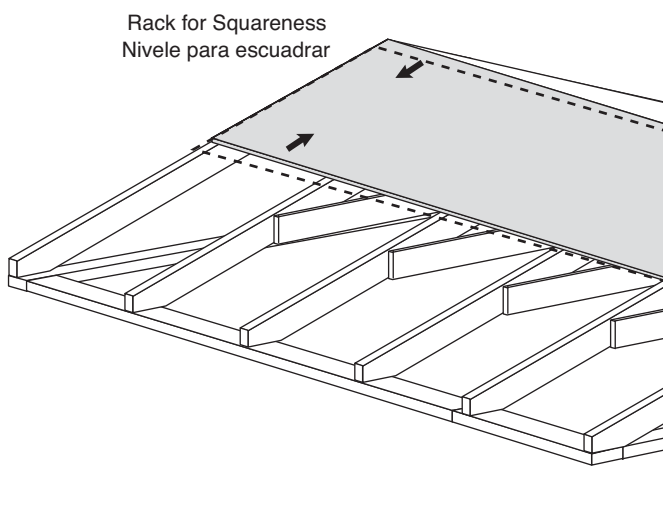

Alineando un techo

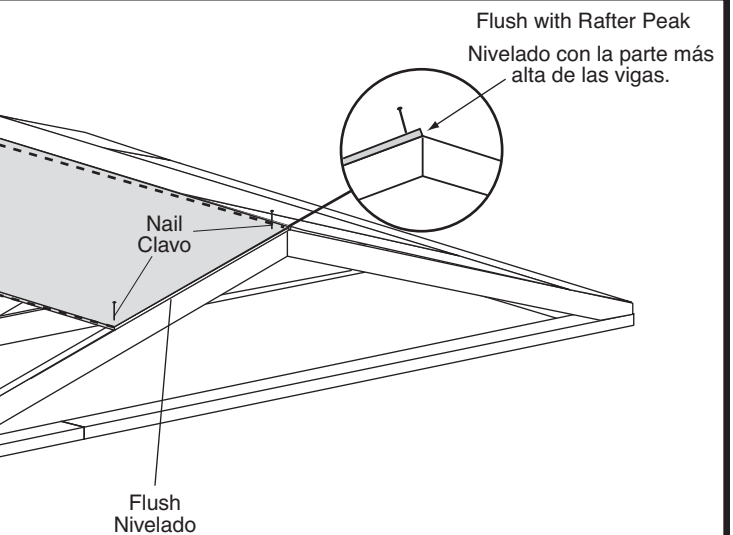

Position panel flush with outside front edge of rafter and nail in two corners as shown. Rack panel square by moving opposite end up or down until panel is flush along peak of rafters and secure with one nail in each corner. Ensure spacing of center rafters and nail as instructed.

Posicione los paneles nivelados con el borde delantero exterior de la viga y clave en las dos esquinas como en el dibujo. Alinee escuadra el panel por mover los extremos opuestos arriba o abajo hasta que el panel esté nivelado a lo largo del punto más alto de las vigas, y fíjelo con un clavo en cada esquina. Compruebe el espacio de las vigas centrales y clave como indicado.

WALL #9

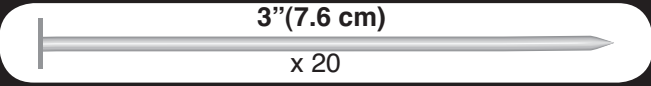

MURO #9

Top
Parte Superior

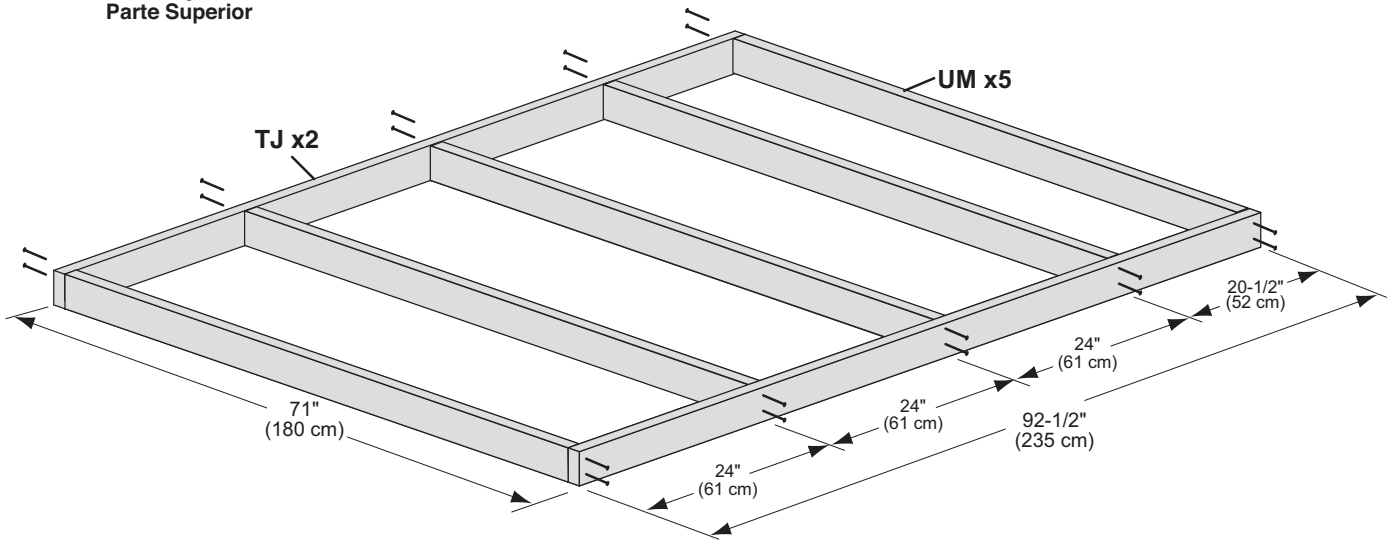

End View
Vista terminal

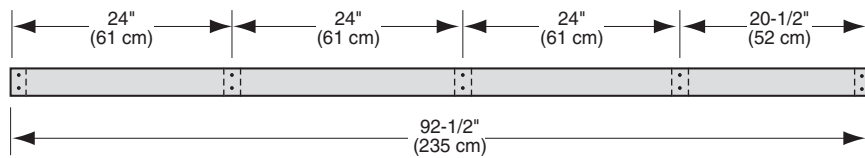

WALL #9

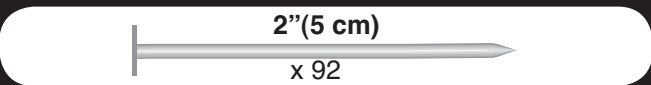

MURO #9

See Page 8 For Building Tip!!!

¡Ver la página 8 para un consejo!!!

Top
Parte Superior

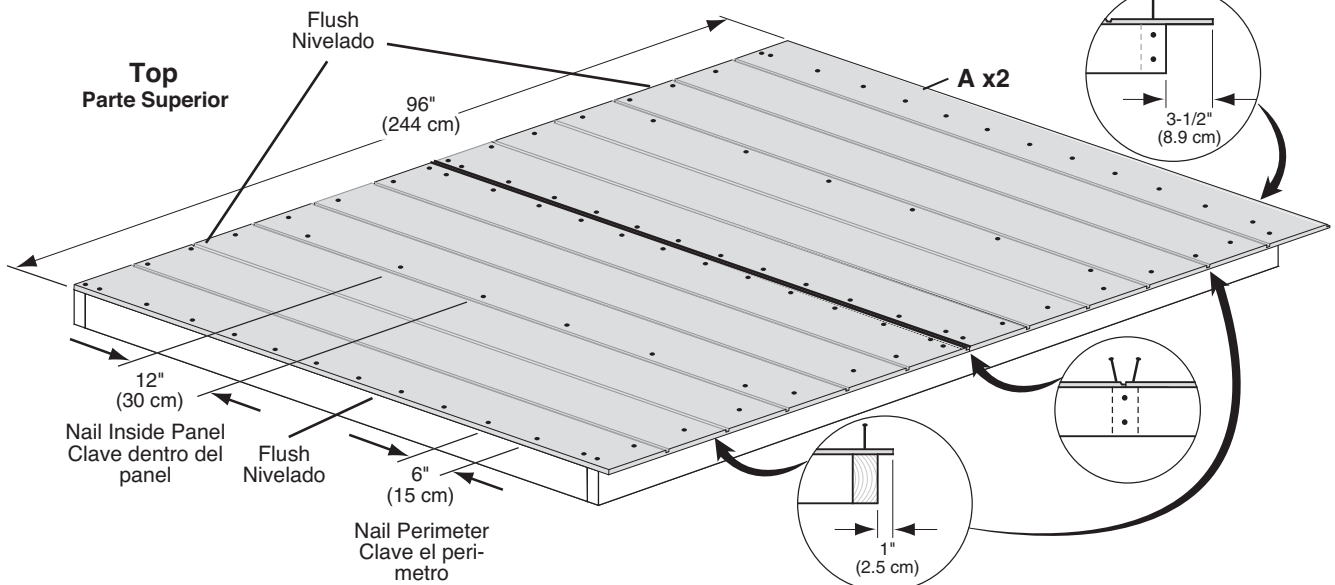

End View
Vista terminal

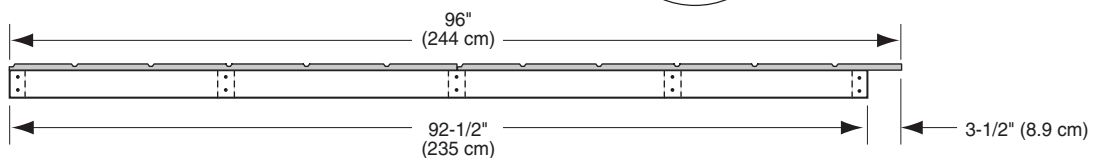

WALL #10

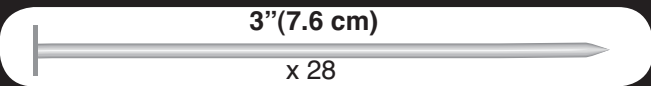

MURO #10

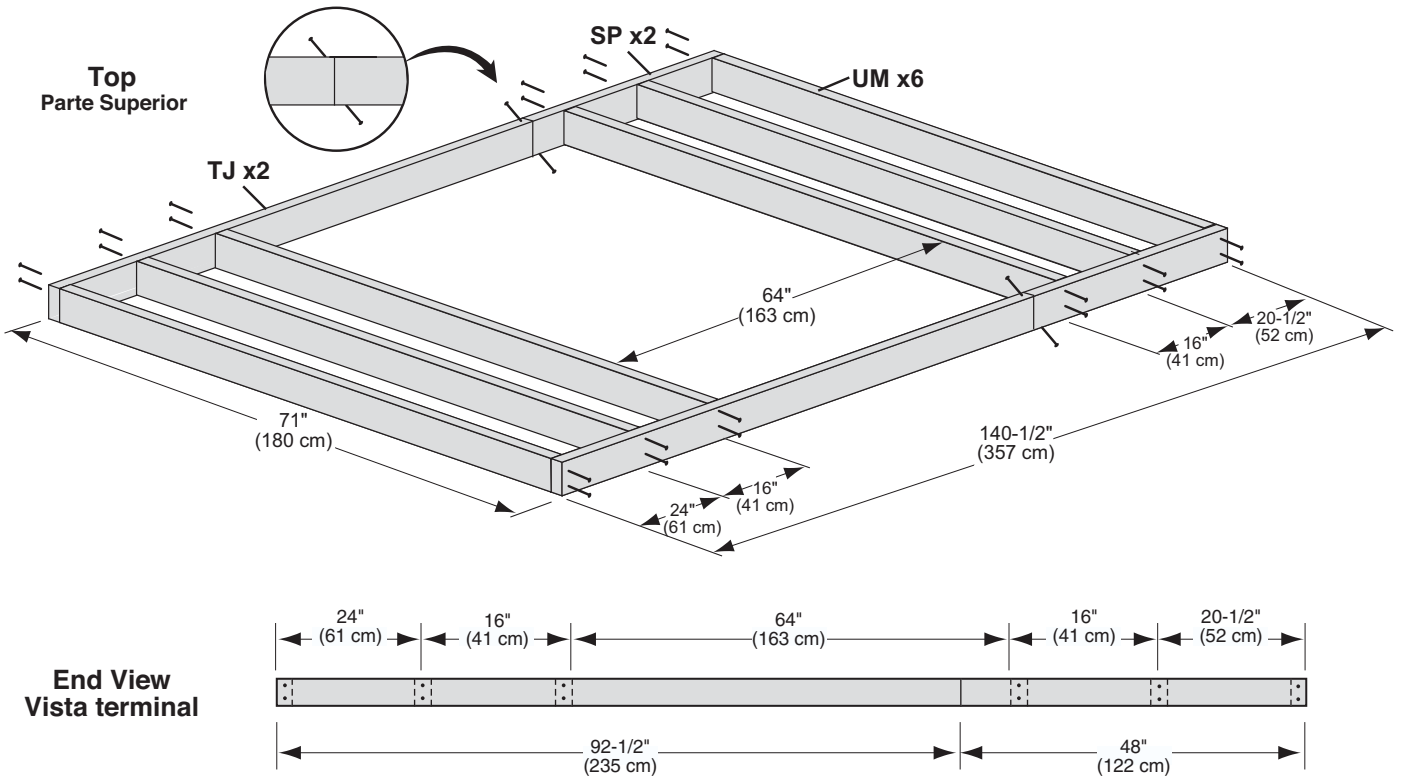

WALL #10

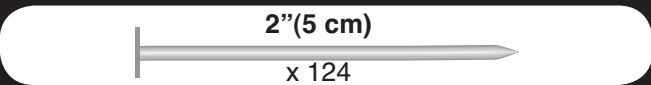

MURO #10

See Page 8 For Building Tip!!!

¡Ver la página 8 para un consejo!!!

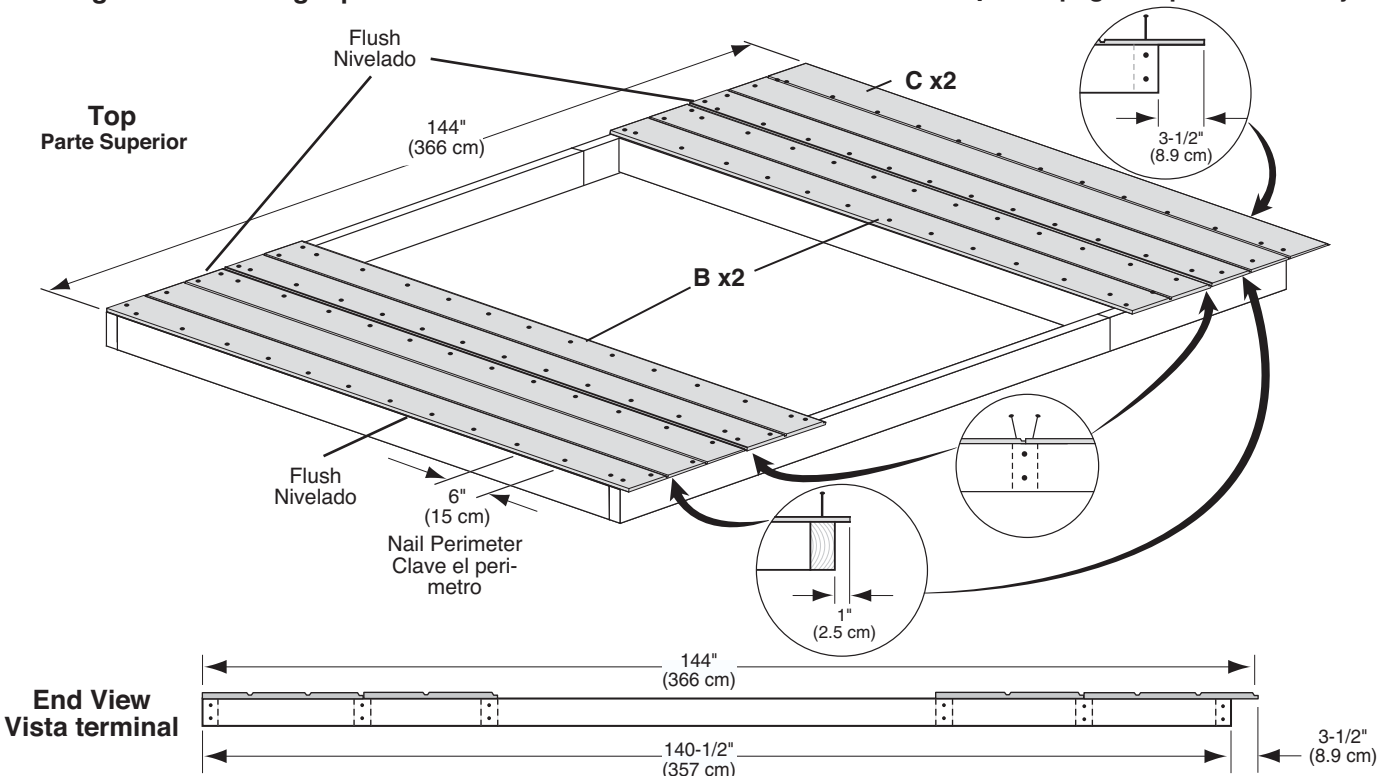

WALL #11

3" (7.6 cm)

x 28

MURO #11

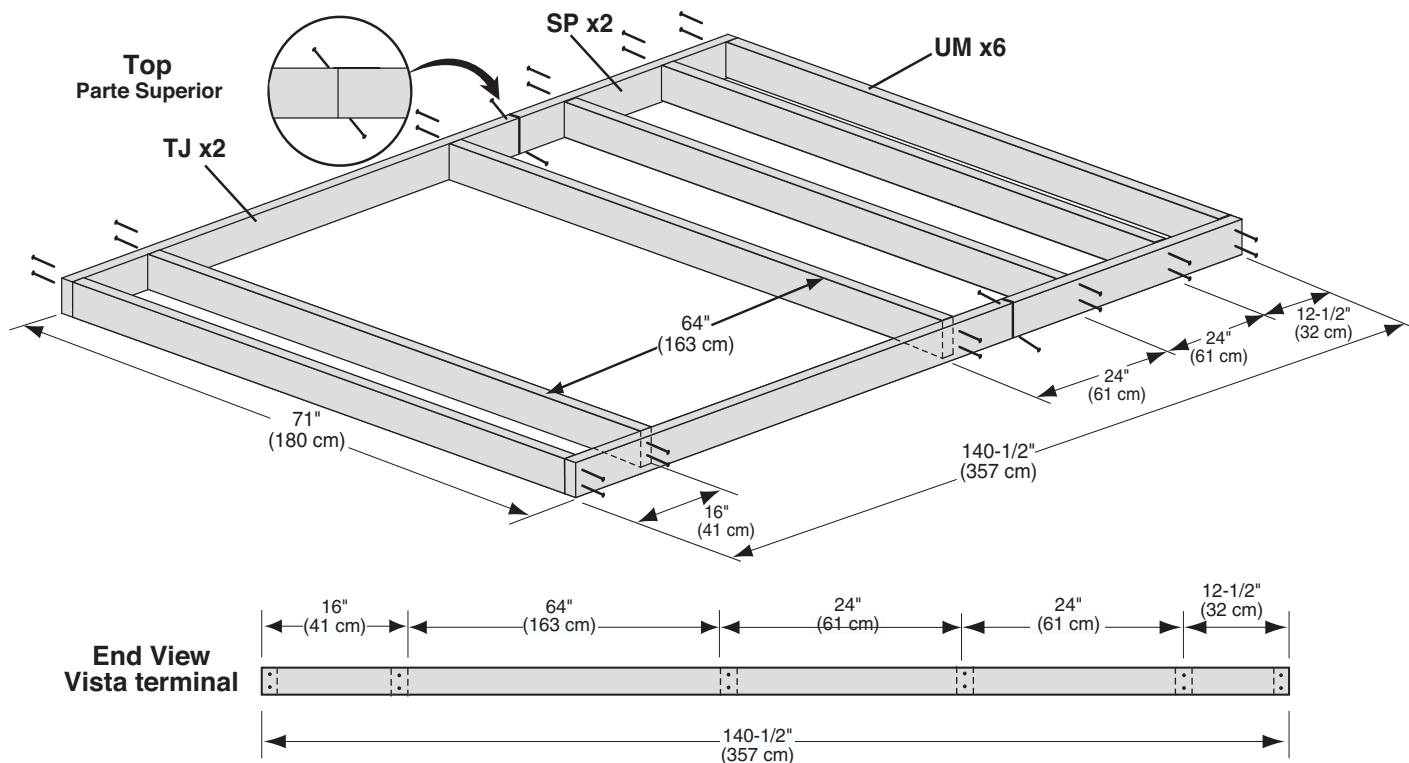

WALL #11

2" (5 cm)

x 124

MURO #11

See Page 8 For Building Tip!!!

¡Ver la página 8 para un consejo!!!

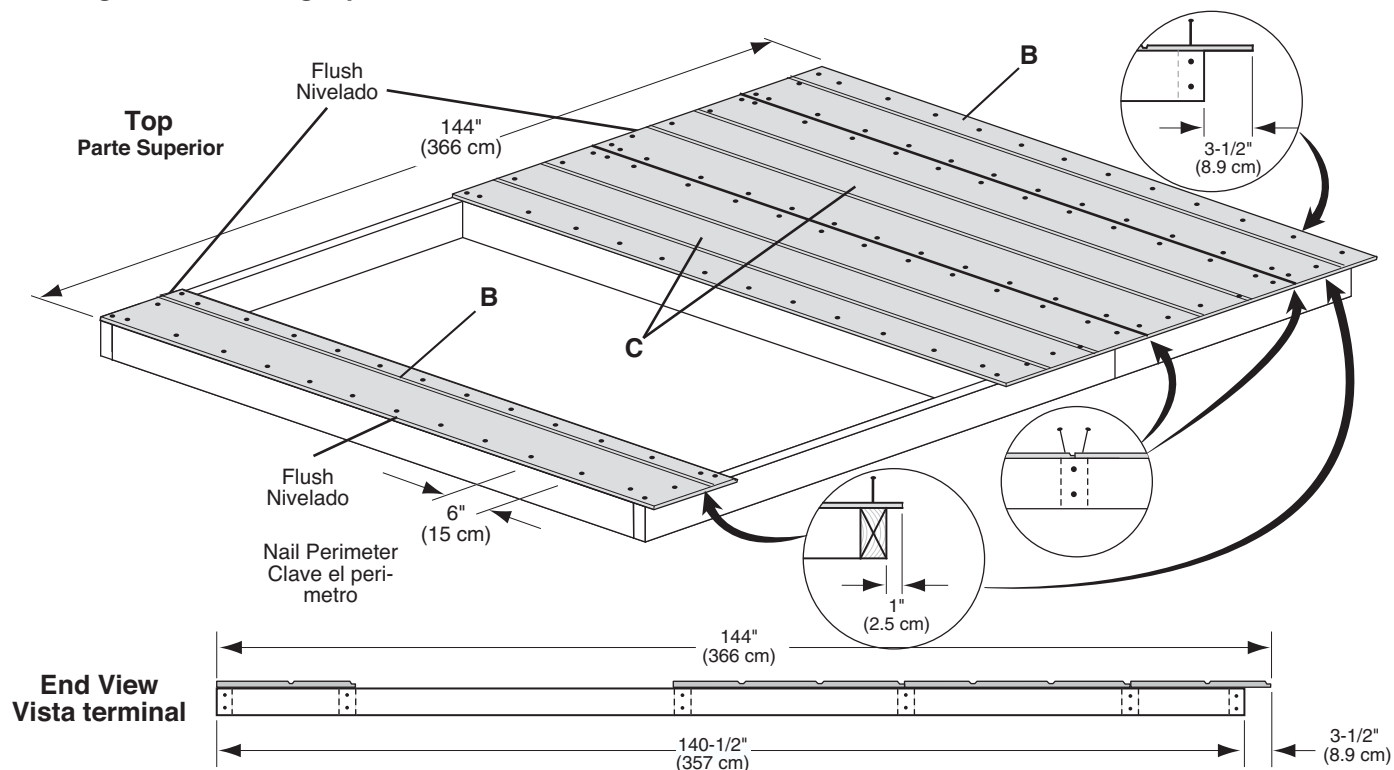

WALL #12

3"(7.6 cm)

x 28

MURO #12

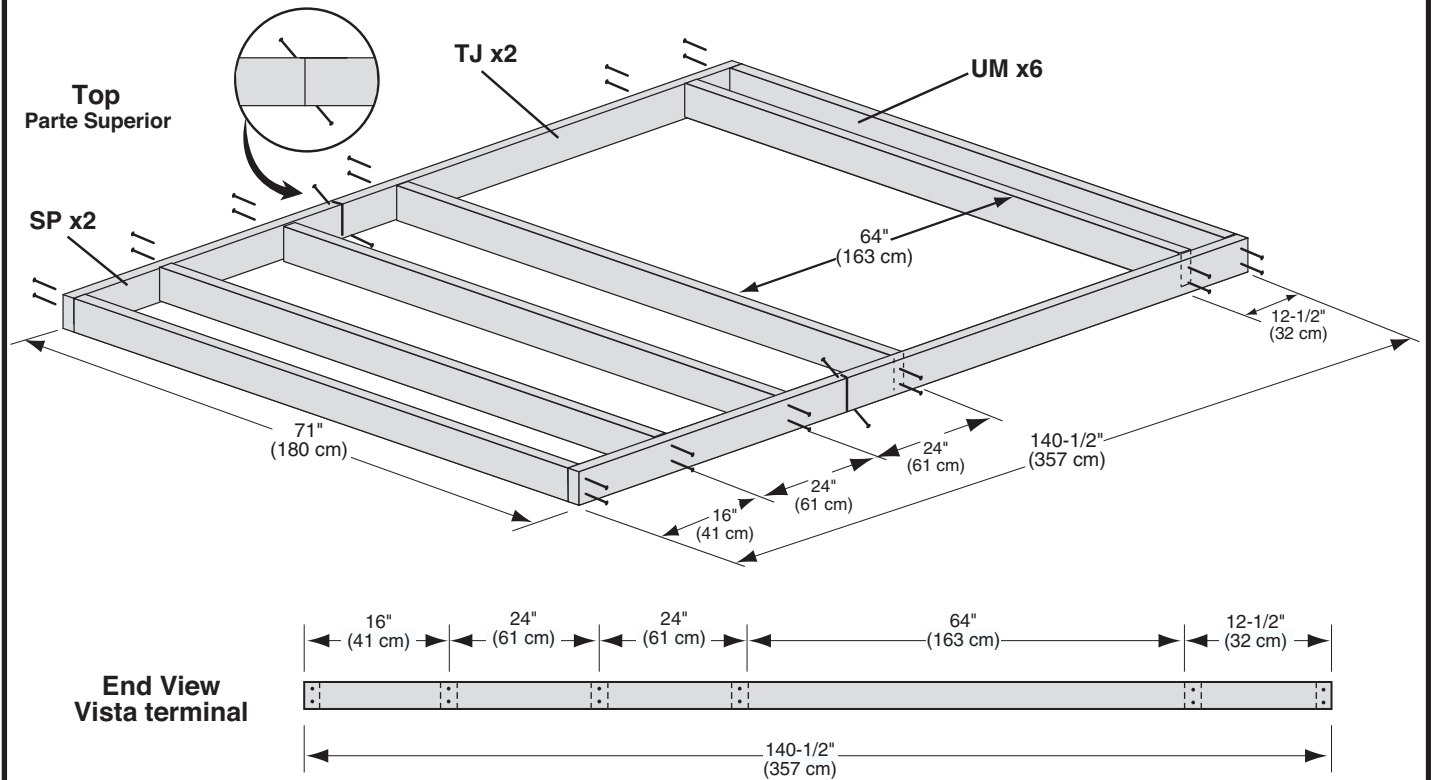

WALL #12

2"(5 cm)

x 124

MURO #12

See Page 8 For Building Tip!!!

¡Ver la página 8 para un consejo!!!

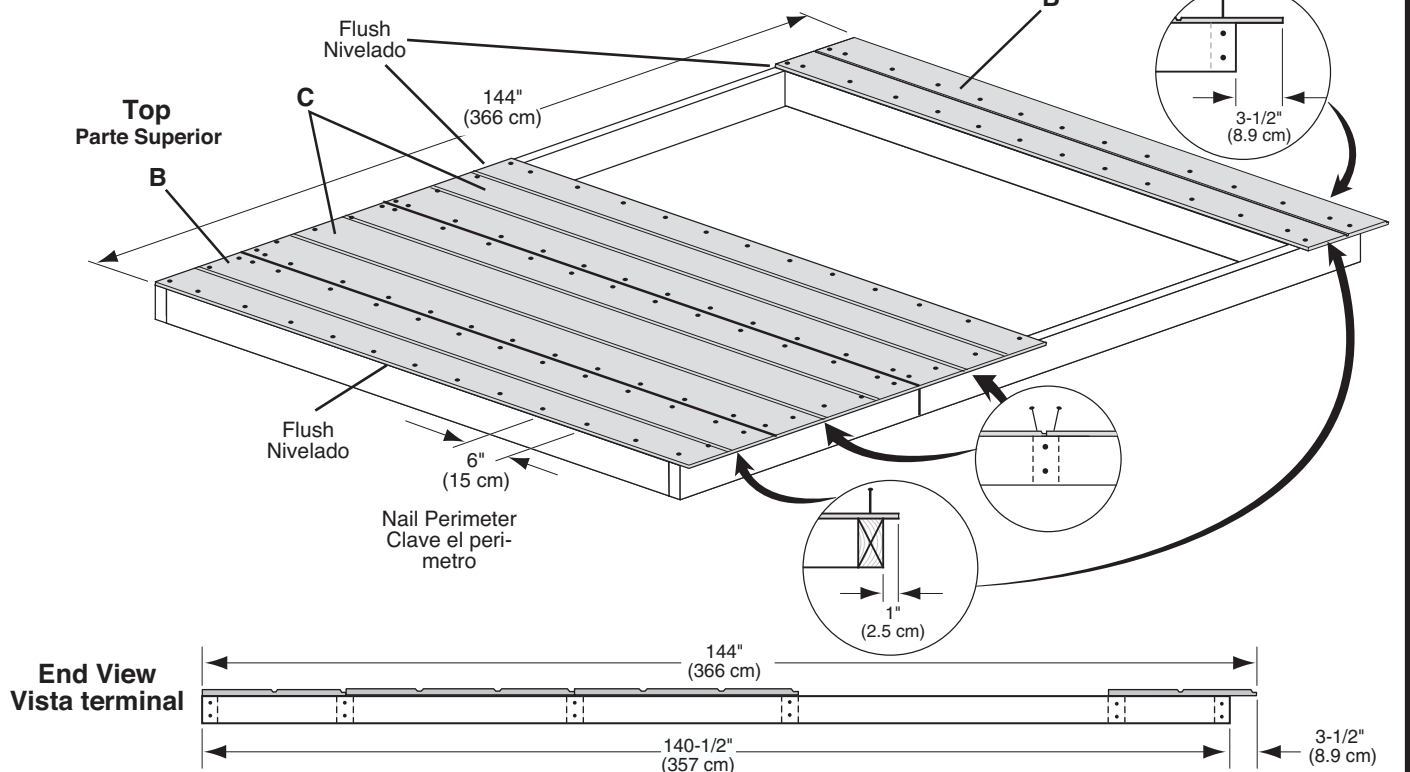

WALL #13

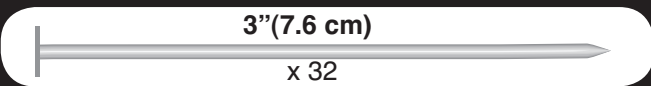

MURO #13

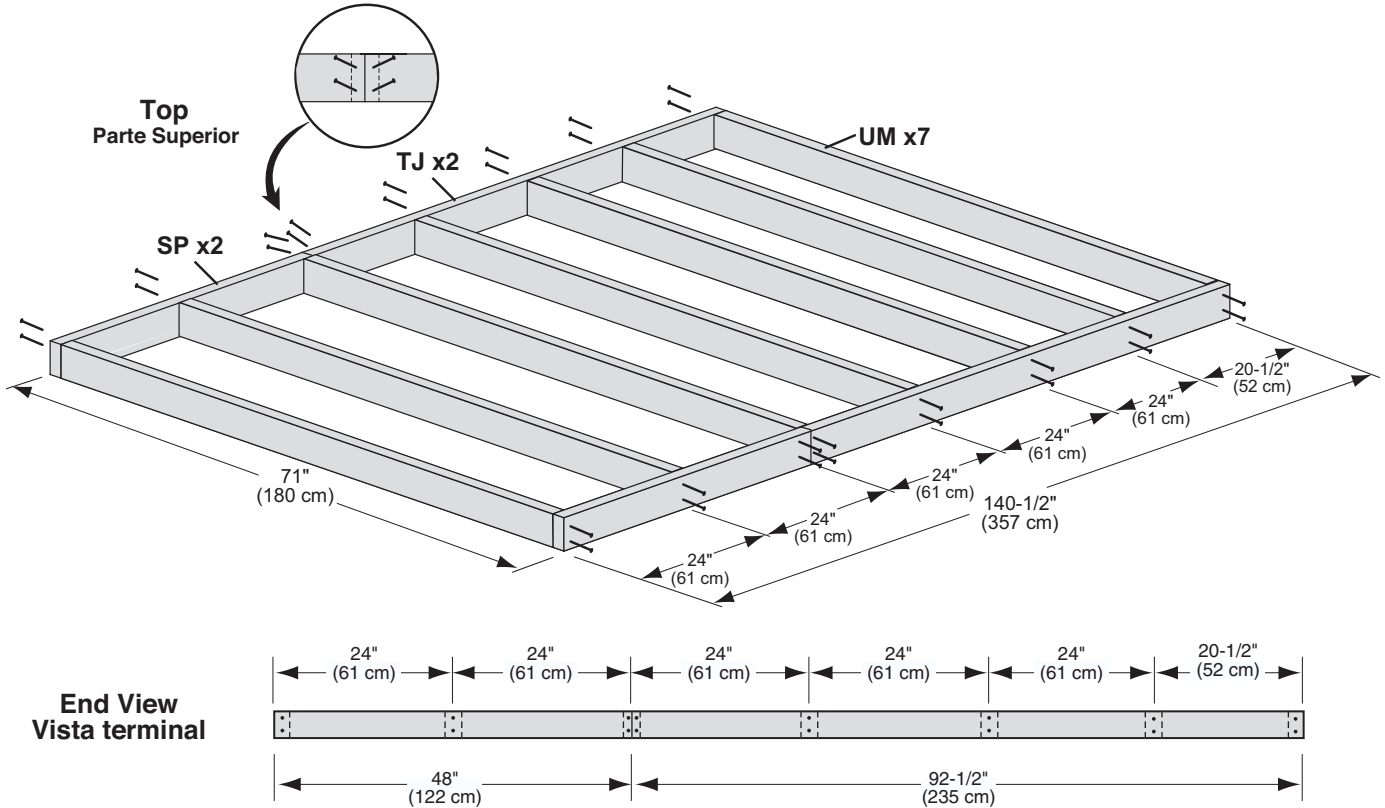

WALL #13

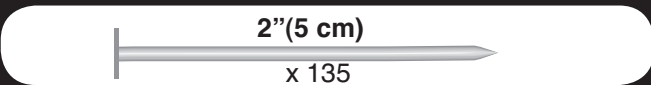

MURO #13

See Page 8 For Building Tip!!!

¡Ver la página 8 para un consejo!!!

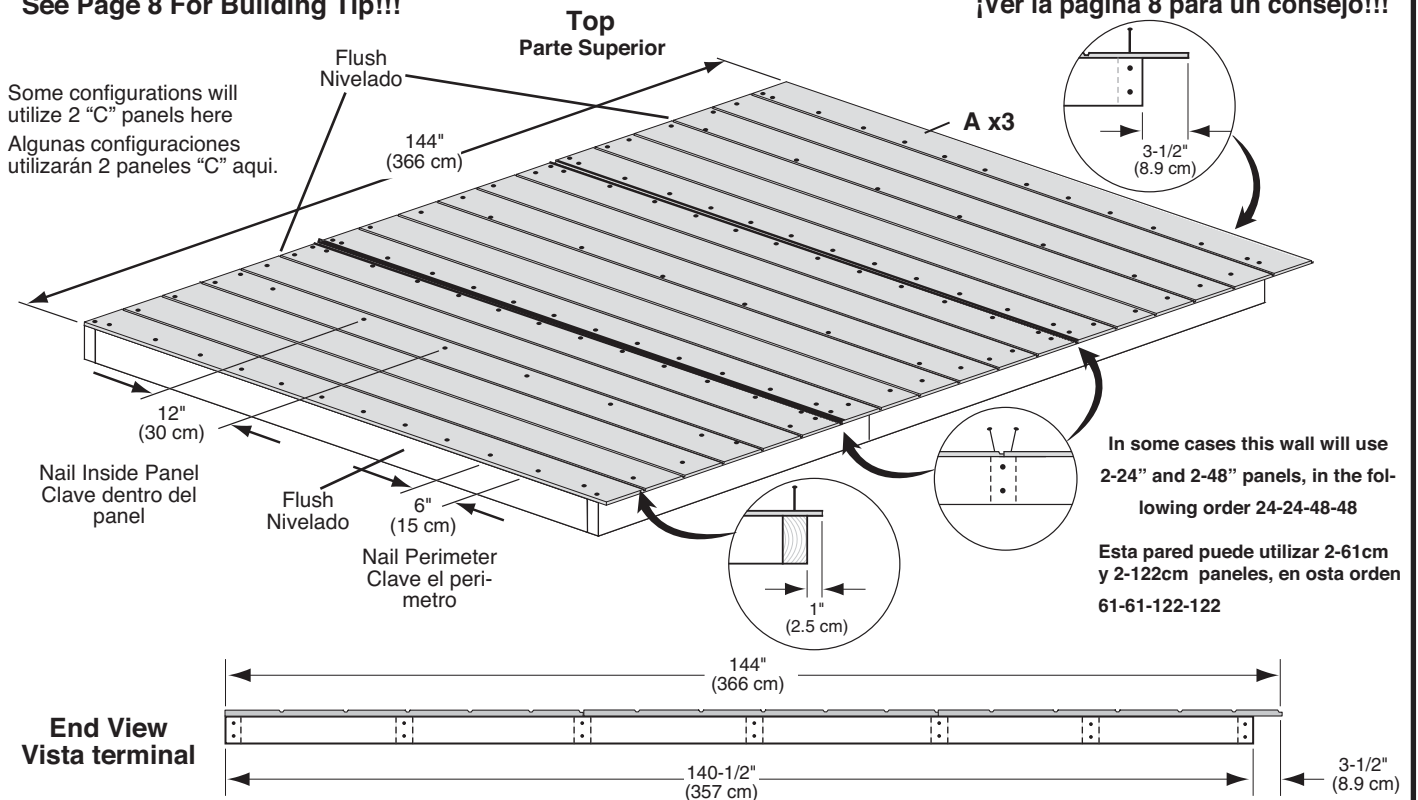

WALL #14

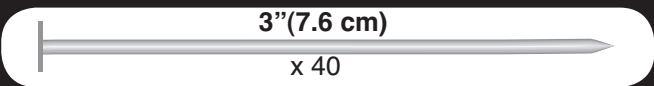

MURO #14

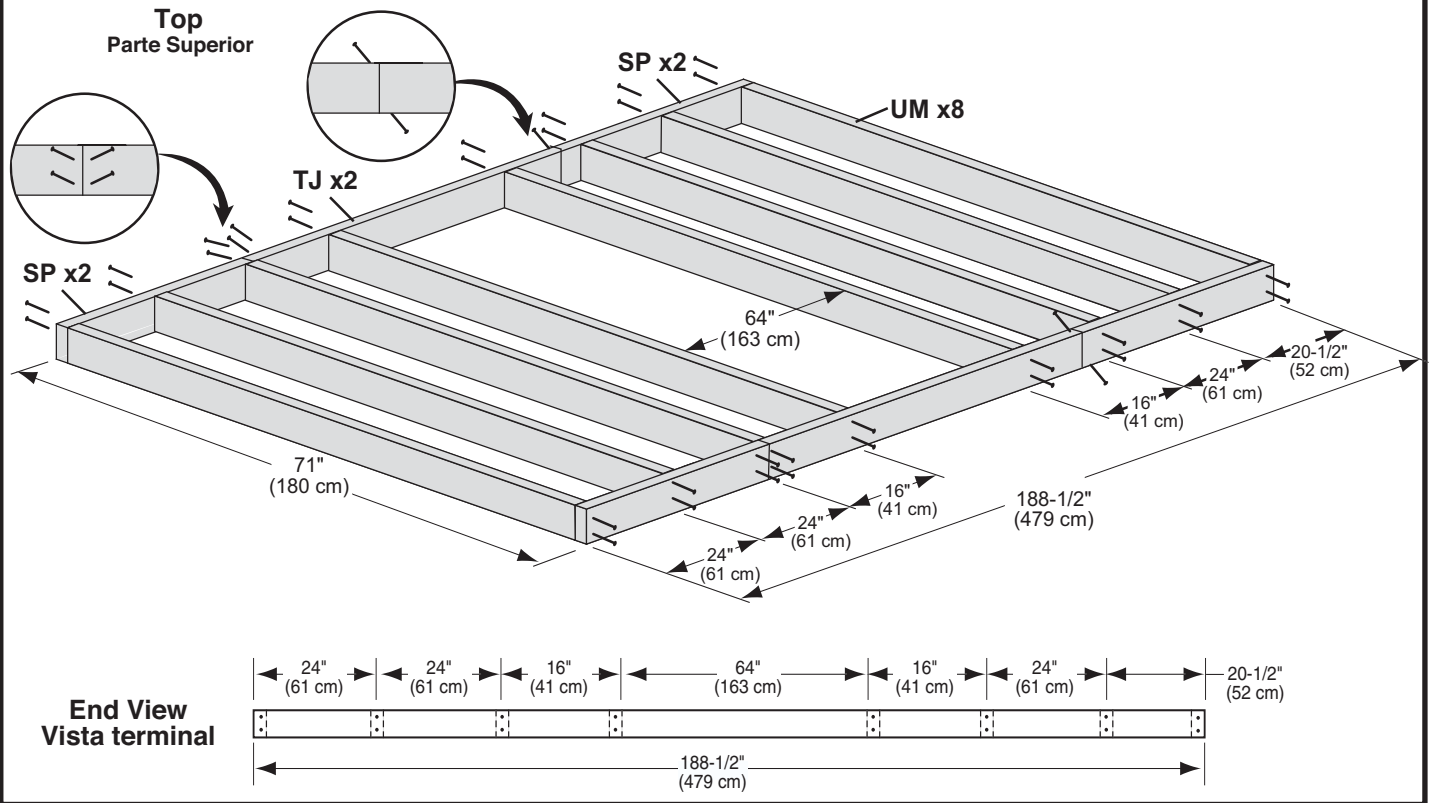

WALL #14

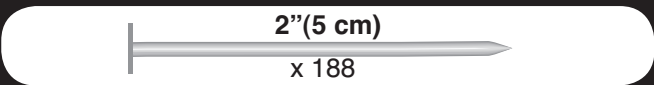

MURO #14

See Page 8 For Building Tip!!!

¡Ver la página 8 para un consejo!!!

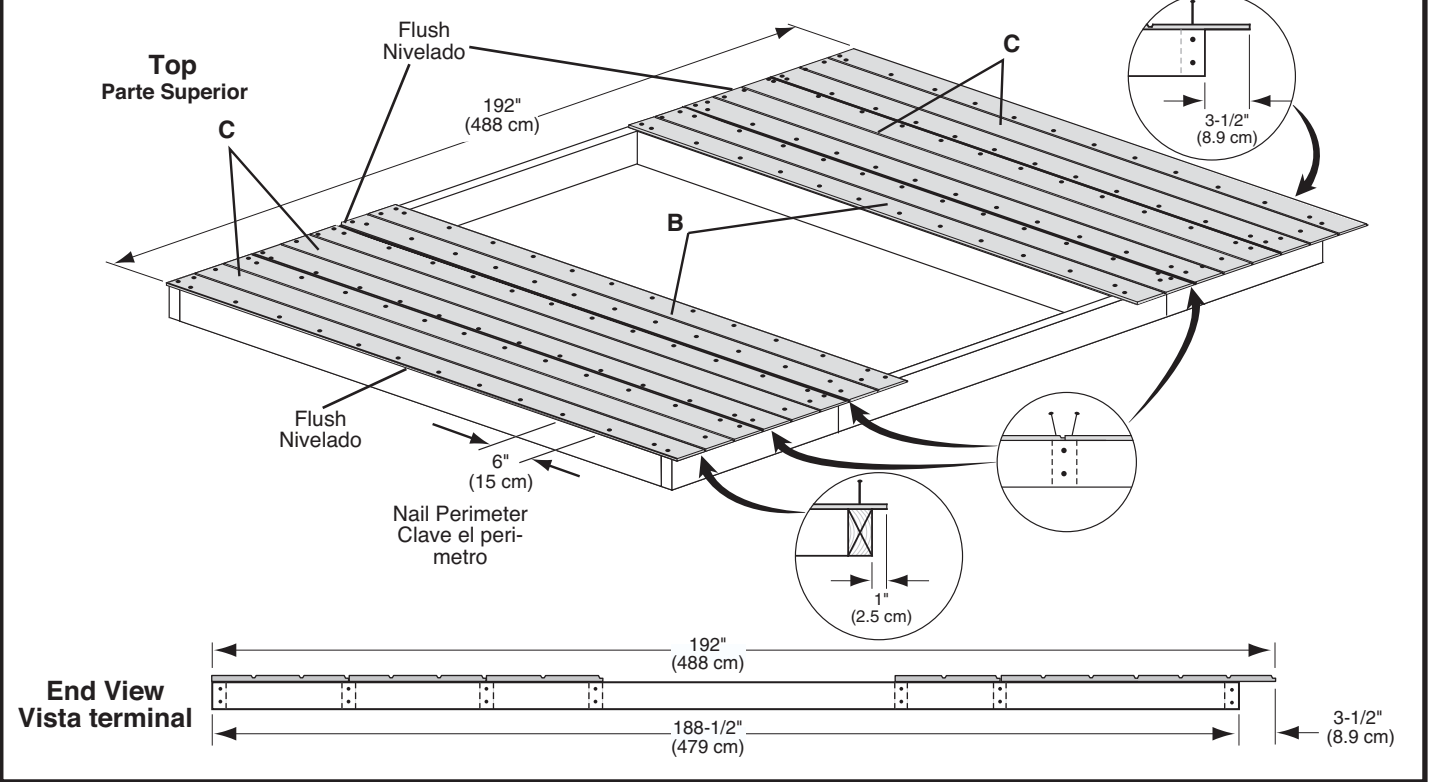

WALL #15

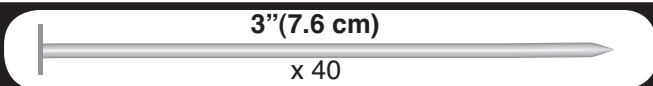

MURO #15

Top
Parte Superior

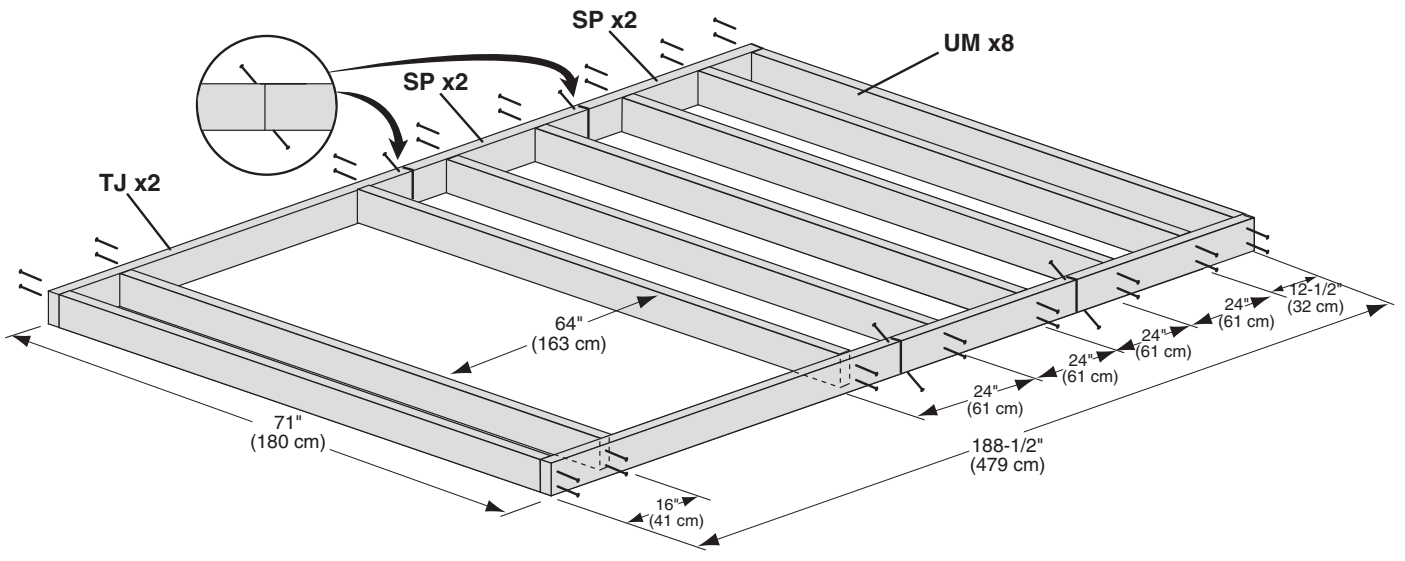

End View
Vista terminal

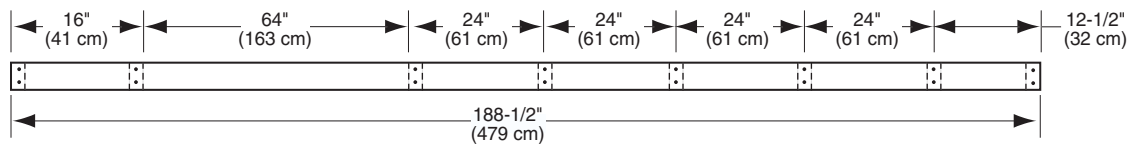

WALL #15

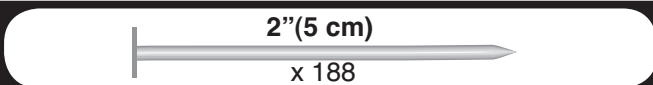

MURO #15

See Page 8 For Building Tip!!!

¡Ver la página 8 para un consejo!!!

Top
Parte Superior

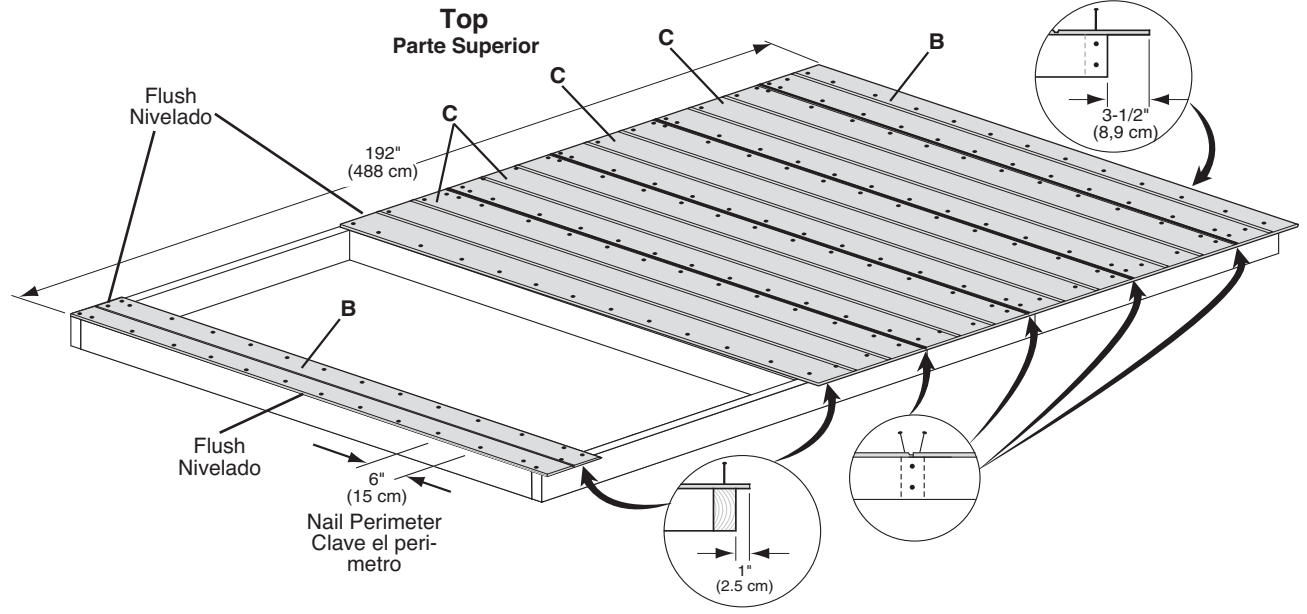

End View
Vista terminal

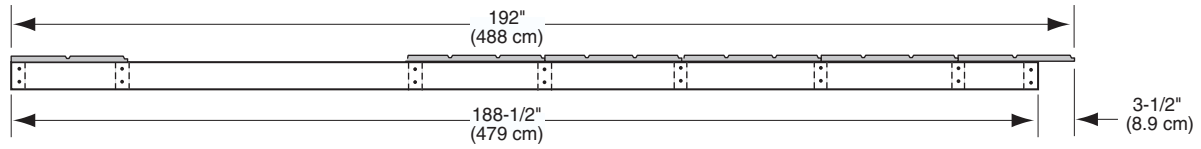

WALL #16

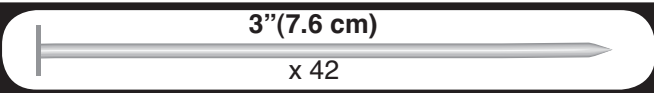

MURO #16

Top
Parte Superior

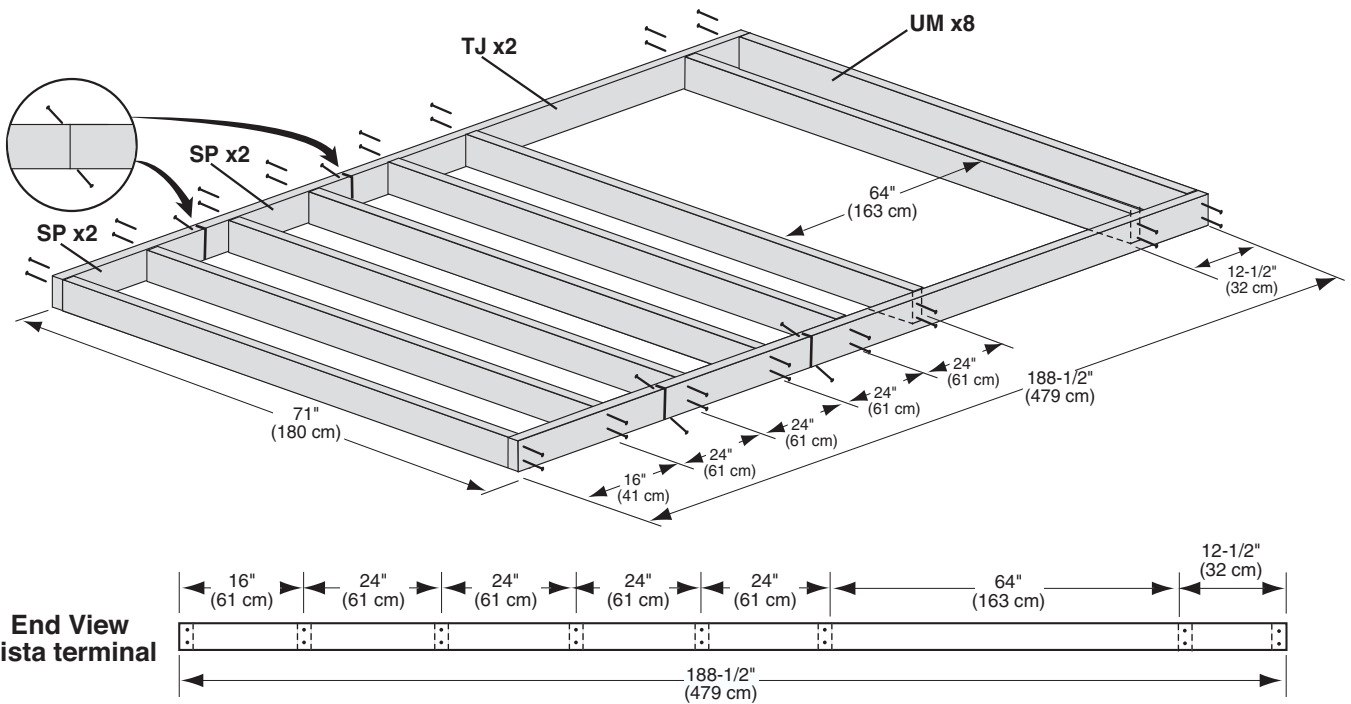

WALL #16

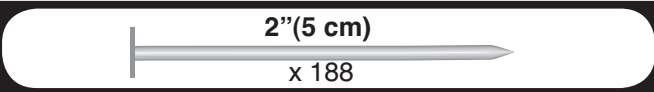

MURO #16

See Page 8 For Building Tip!!!

¡Ver la página 8 para un consejo!!!

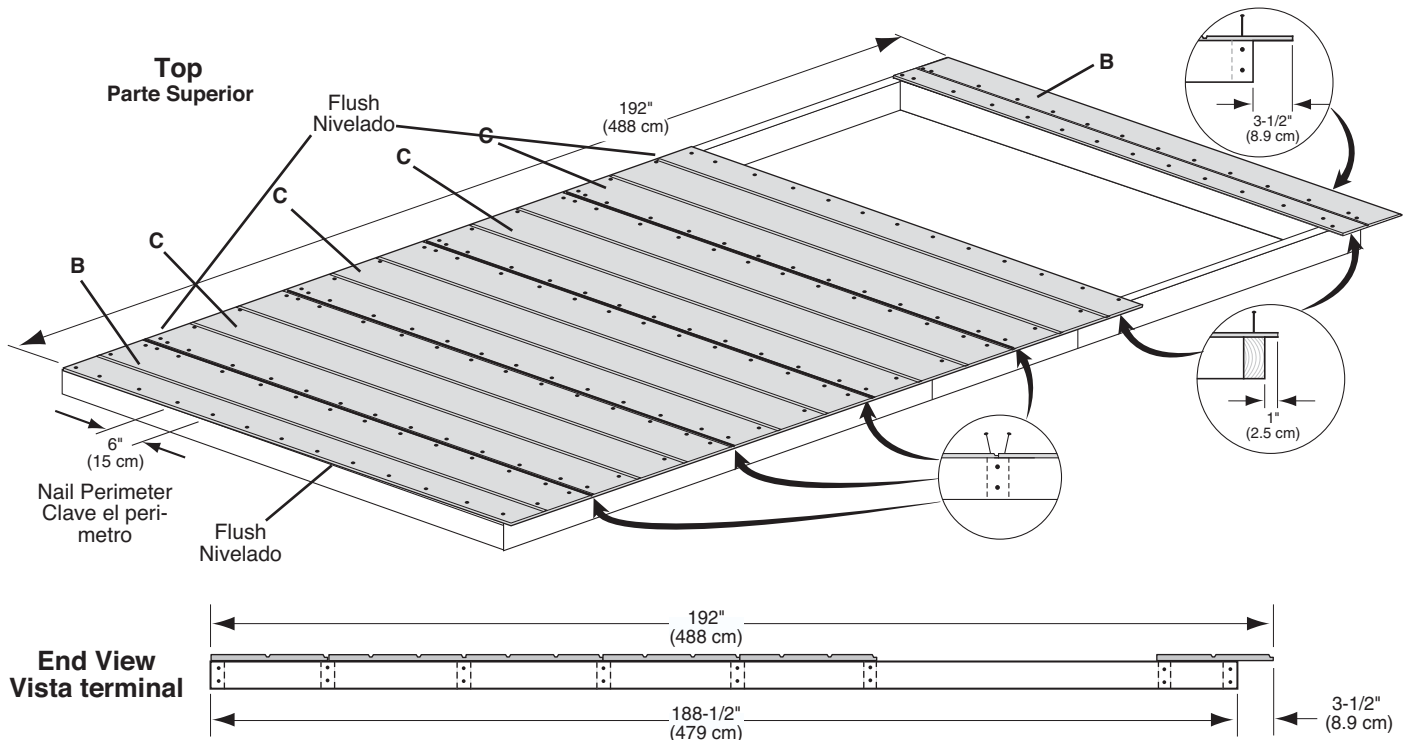

WALL #17

3"(7.6 cm)

x 44

MURO #17

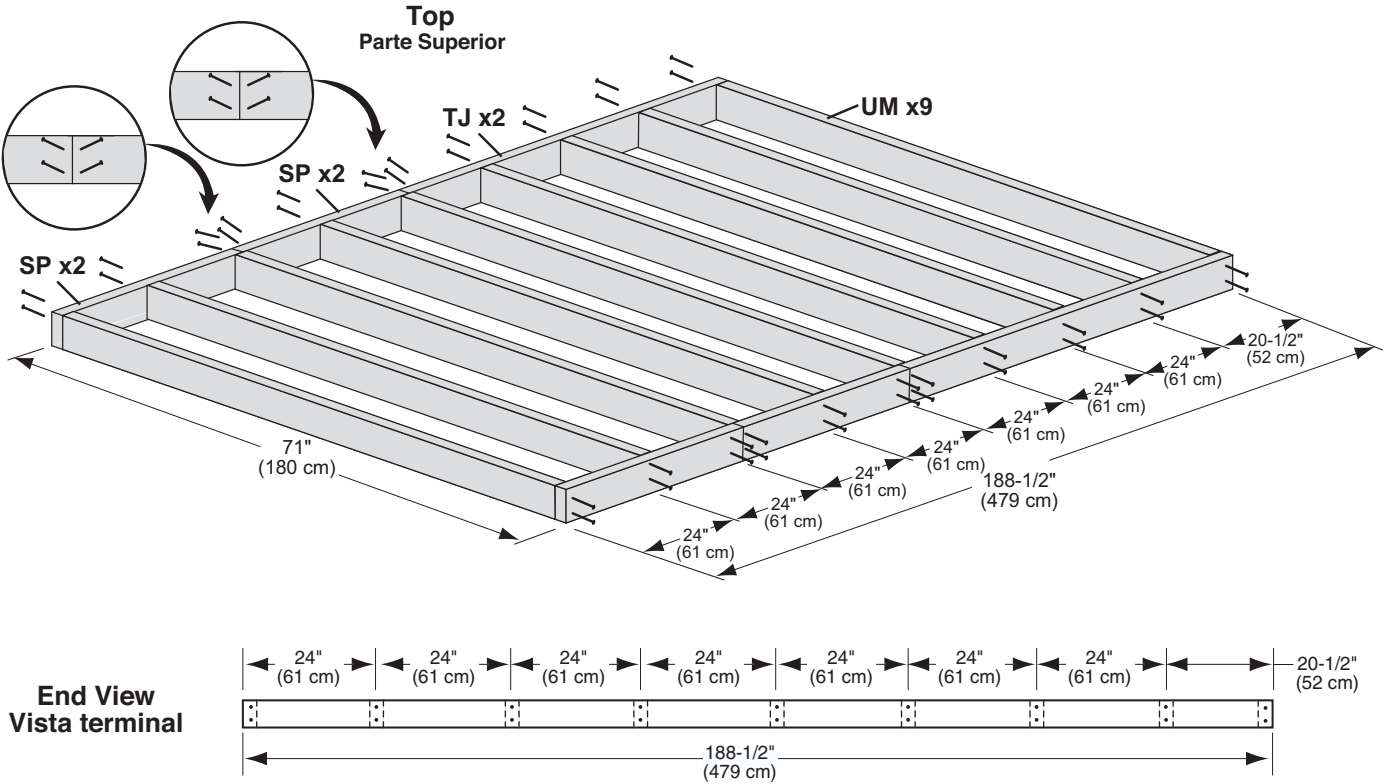

WALL #17

2"(5 cm)

x 180

MURO #17

See Page 8 For Building Tip!!!

¡Ver la página 8 para un consejo!!!

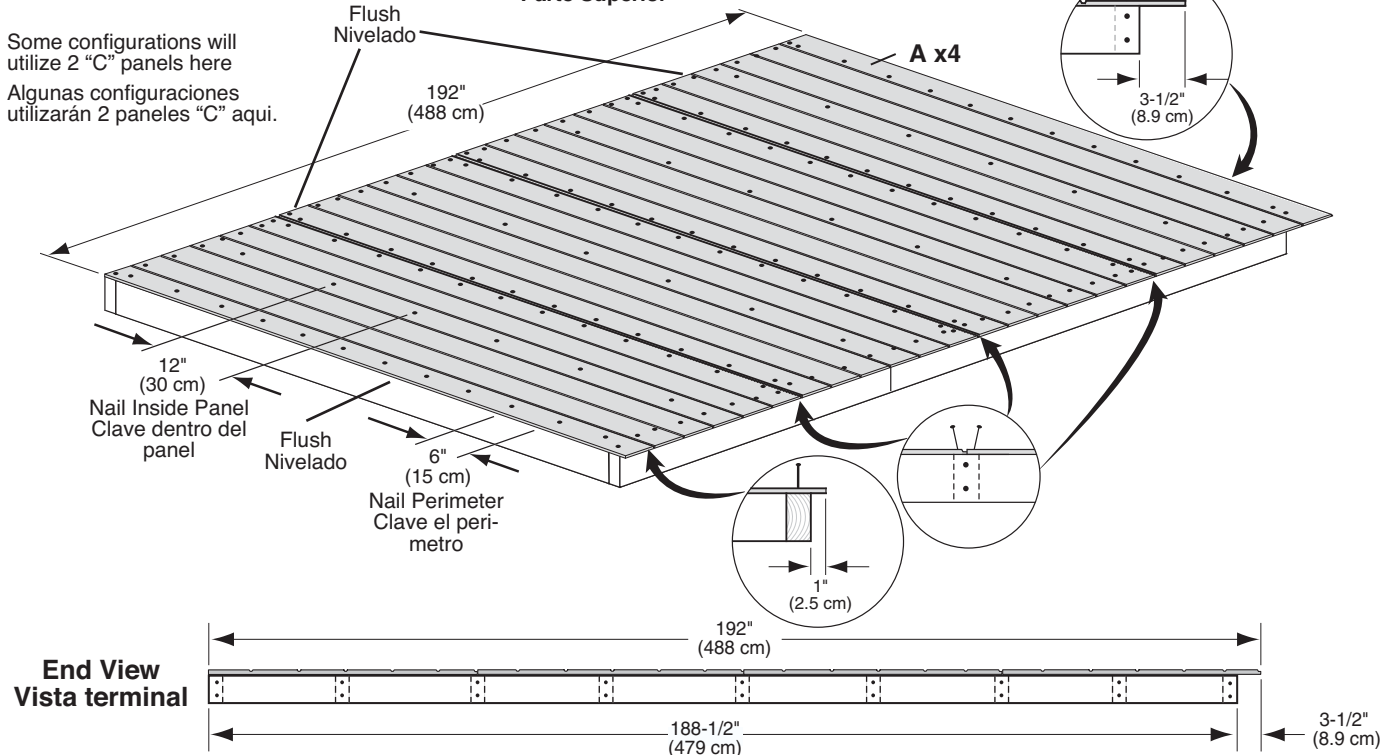

ERECTING WALLS

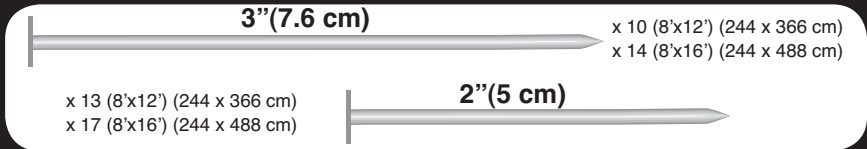

CONSTRUYENDO LOS MUROS

See Page 7 for Building Tip!!!

¡Ver la página 7 para un consejo!

ERECT SOLID WALLS FIRST
CONSTRUYA LOS MUROS SÓLIDOS PRIMERO

See Page 6 for wall #
Ver la página 6 para # muro.

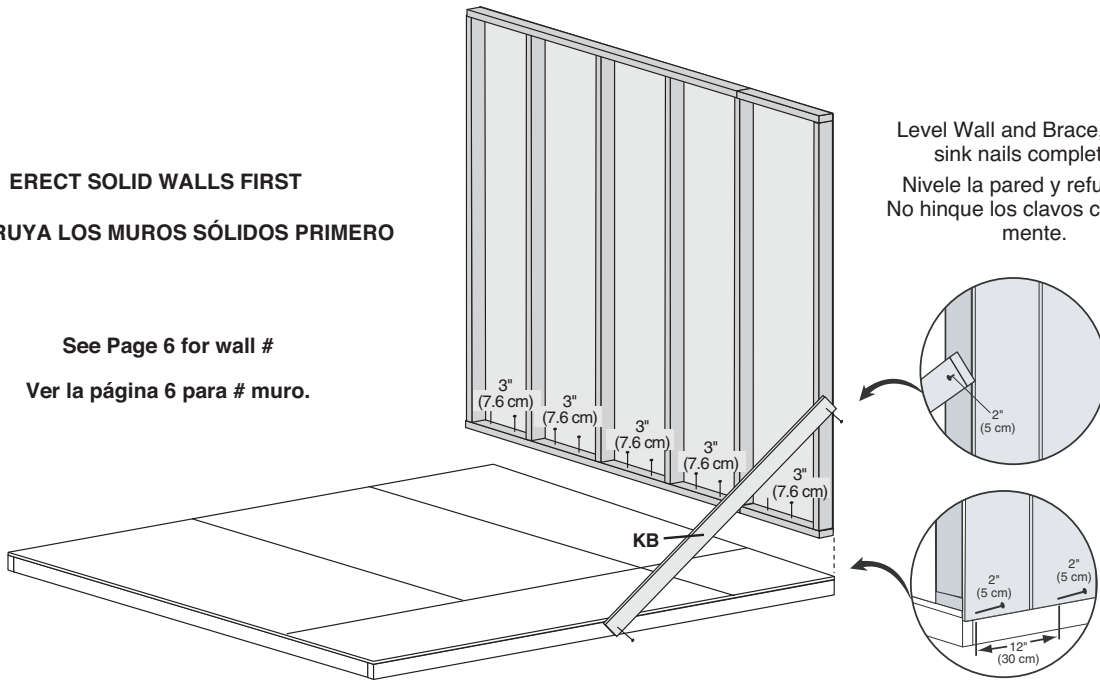

Level Wall and Brace, Do not sink nails completely.
Nivele la pared y refuérzala. No hínque los clavos completamente.

ERECTING WALLS

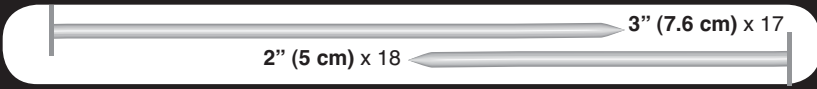

CONSTRUYENDO LOS MUROS

See Page 7 for Building Tip!!!

¡Ver la página 7 para un consejo!

See Page 6 for wall #
Ver la página 6 para # muro.

Level Wall and Nail
Nivele la pared y clave

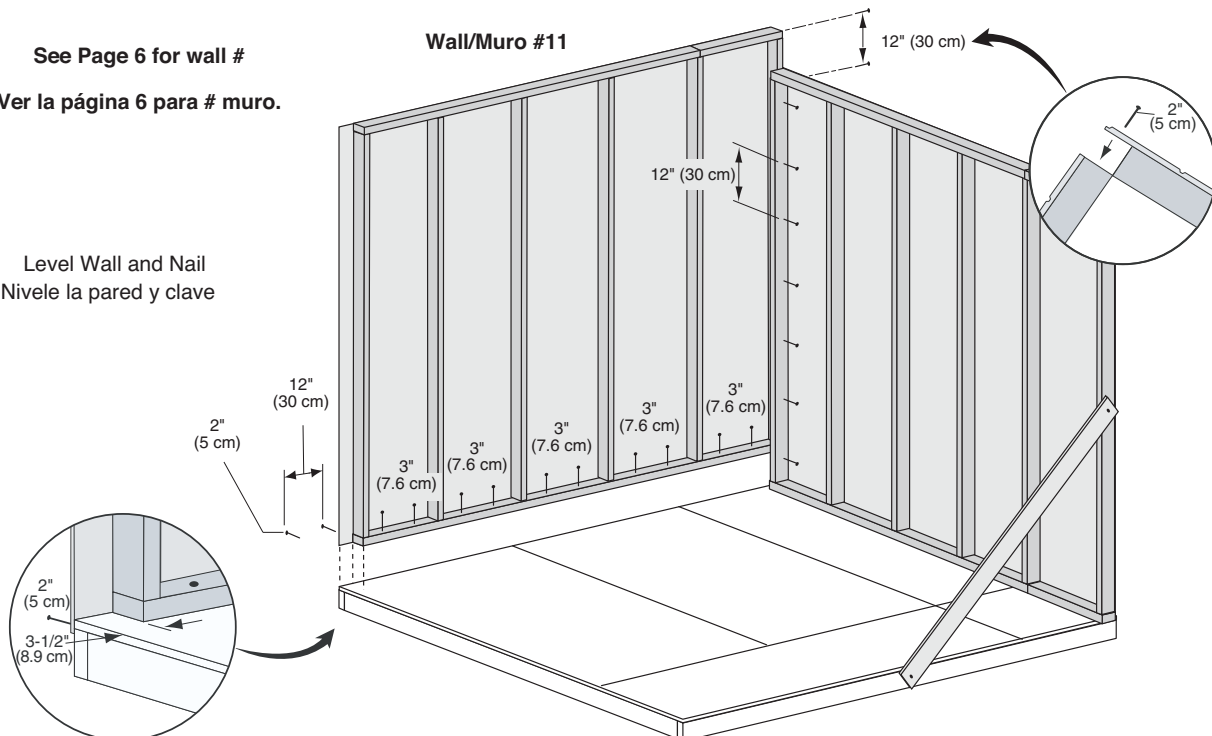

ERECTING WALLS

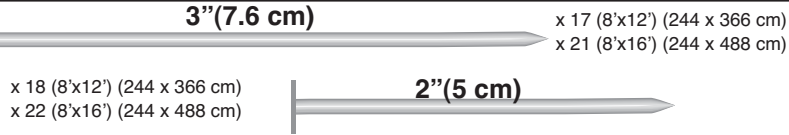

CONSTRUYENDO LOS MUROS

See Page 7 for Building Tip!!!

¡Ver la página 7 para un consejo!

See Page 6 for wall #
Ver la página 6 para # muro

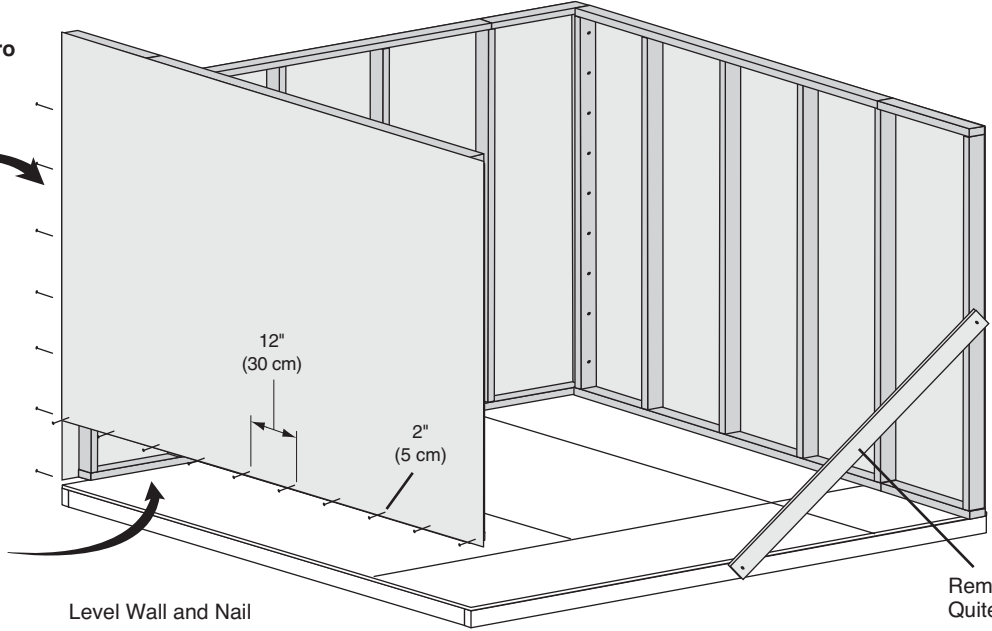
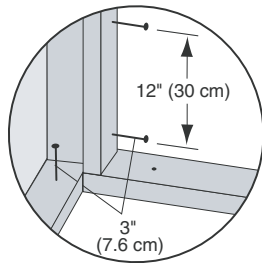
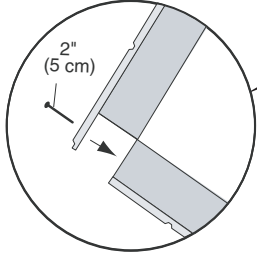

Level Wall and Nail
Nivele la pared y clave

Remove
Quite

ERECTING WALLS



CONSTRUYENDO LOS MUROS

After walls are erected, make sure X to X and Y to Y measurements are the same

Después de construir los muros, asegúrese que las medidas "X a X" y "Y a Y" son iguales.

See Page 6 for wall #
Ver la página 6 para # muro.

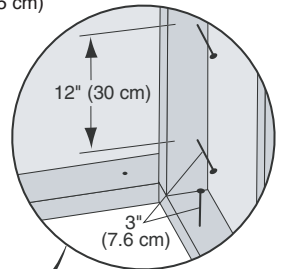
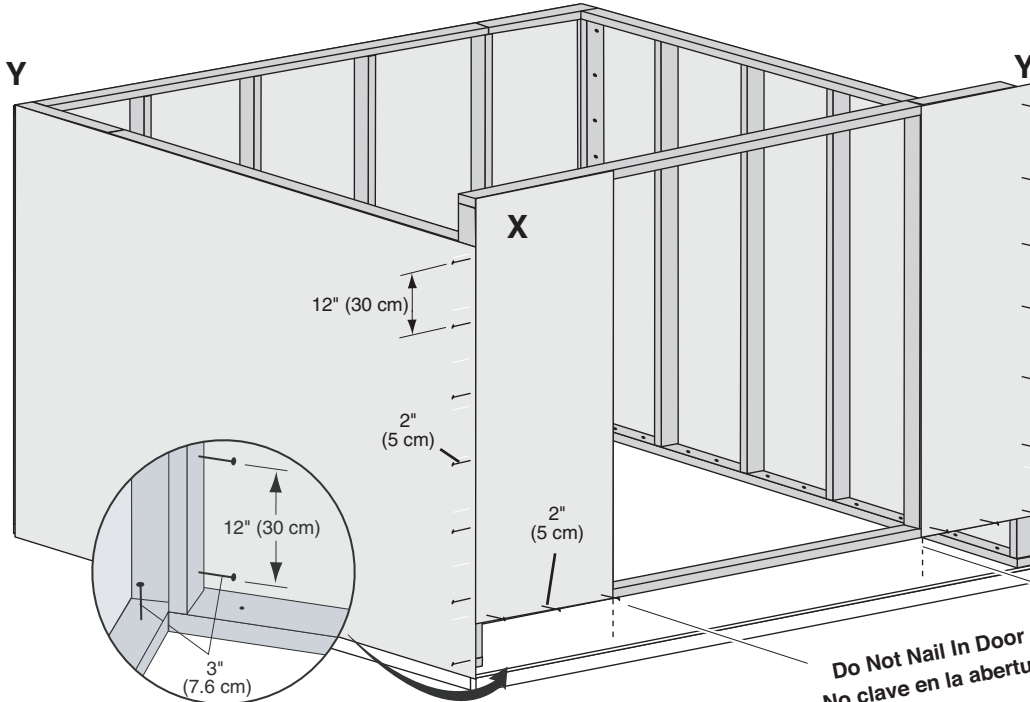

Do Not Nail In Door Opening
No clave en la abertura de la puerta.

DOUBLERS

3"(7.6 cm)

x 56 (8'x12') (244 x 366 cm)
x 68 (8'x16') (244 x 488 cm)

DOBLADORES

**INSTALL AS SHOWN
INSTALE COMO EN EL DIBUJO**

8' X 12' (244 x 366 cm)

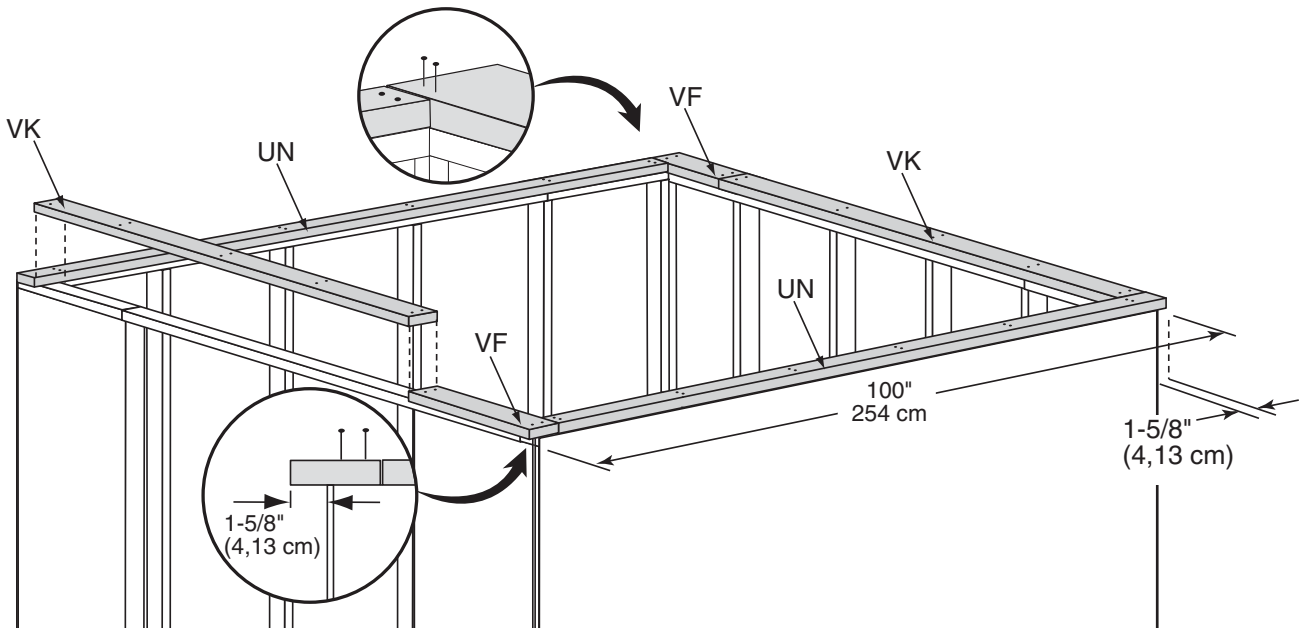

8' X 16' (244 x 488 cm)

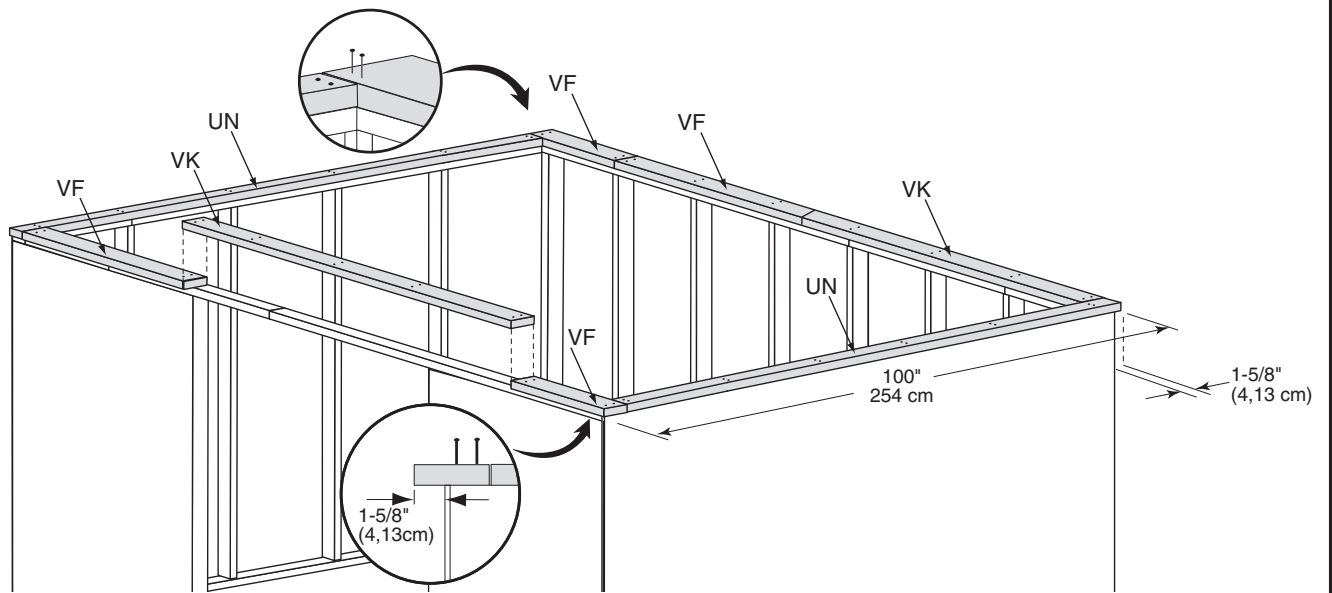

ROOF

1-1/2" (3.8 cm)

x 24

TECHO

End Rafter Assembly x2

Conjunto de vigas terminales x2

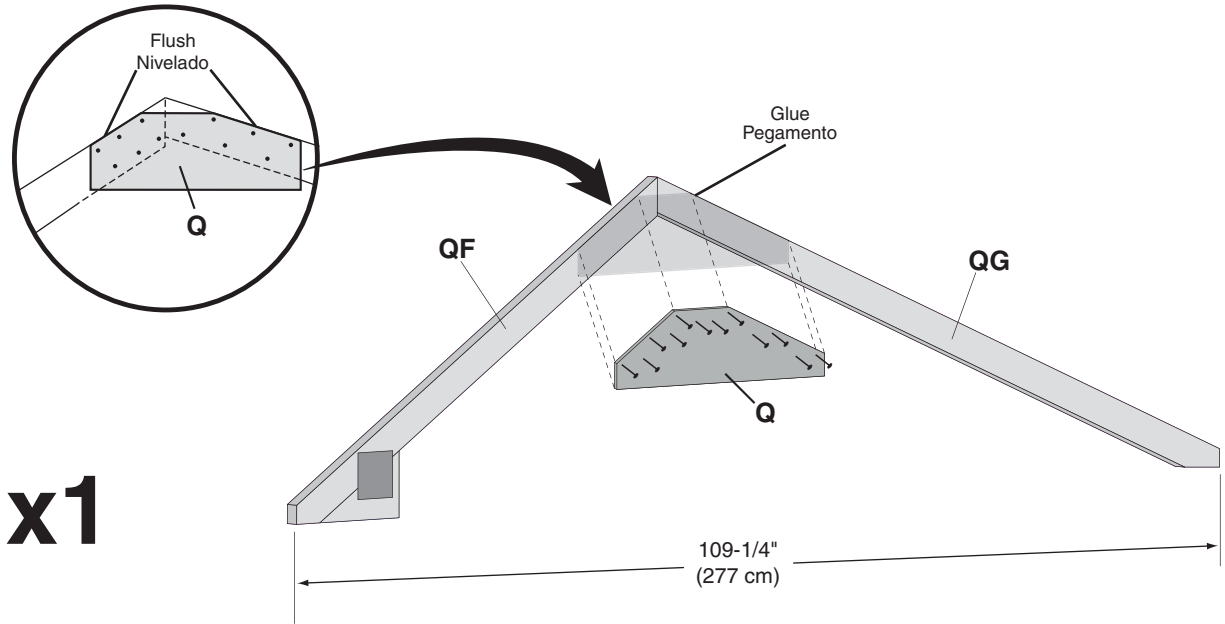

x1

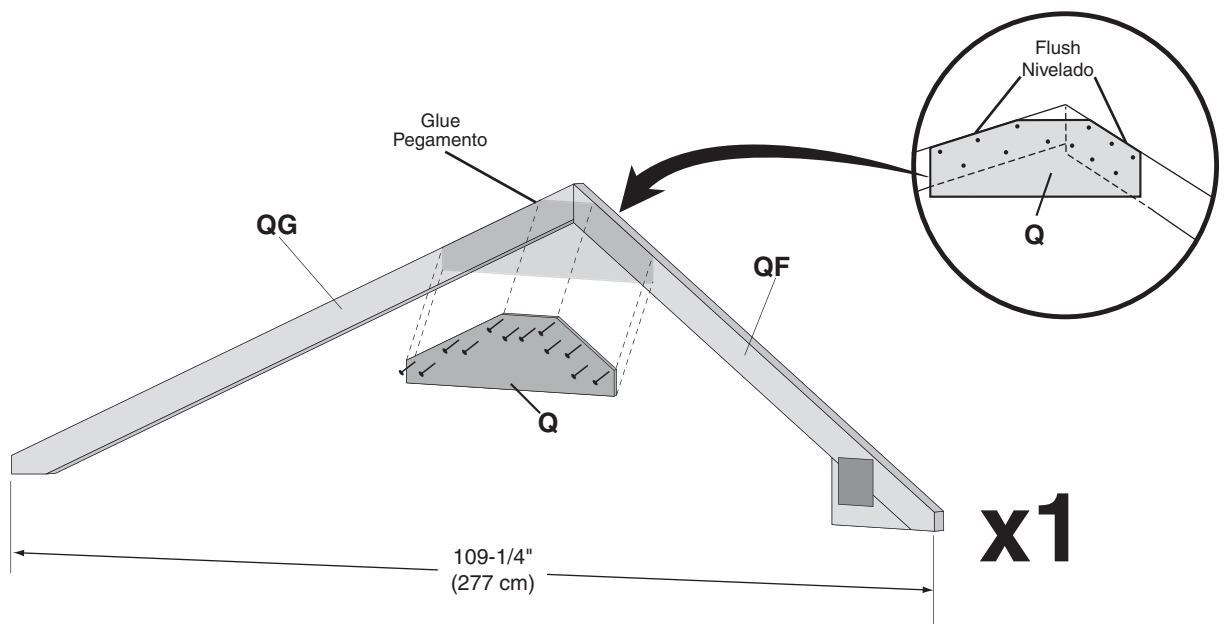

x1

ROOF



TECHO

Middle Rafter Assembly
(See sizes below for quantity)

Conjunto de vigas centrales
(Ver las dimensiones abajo para la cantidad)

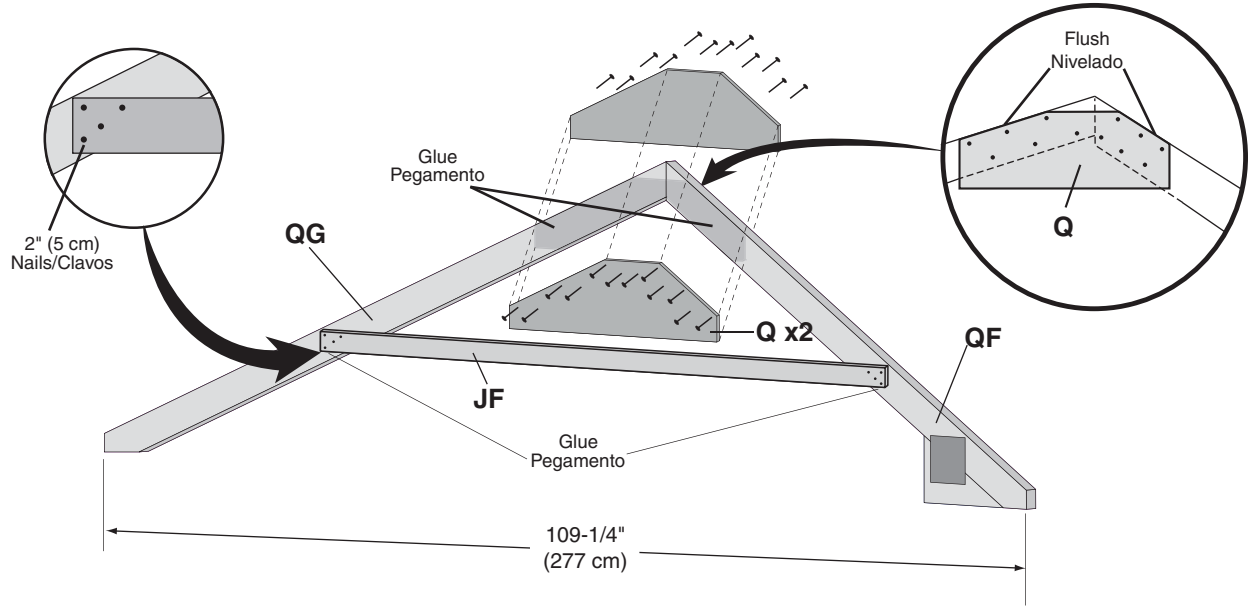

8'x12' (244 x 366 cm)

1-1/2" (3.8 cm) - 96

2" (5 cm) - 32

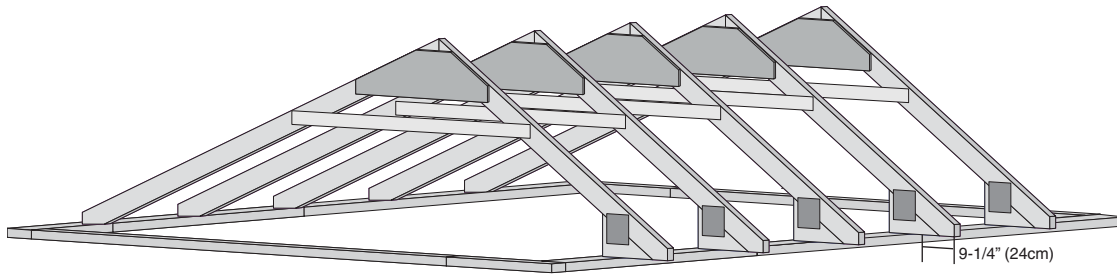

x5

8'x16' (244 x 488 cm)

1-1/2" (3.8 cm) - 144

2" (5 cm) - 48

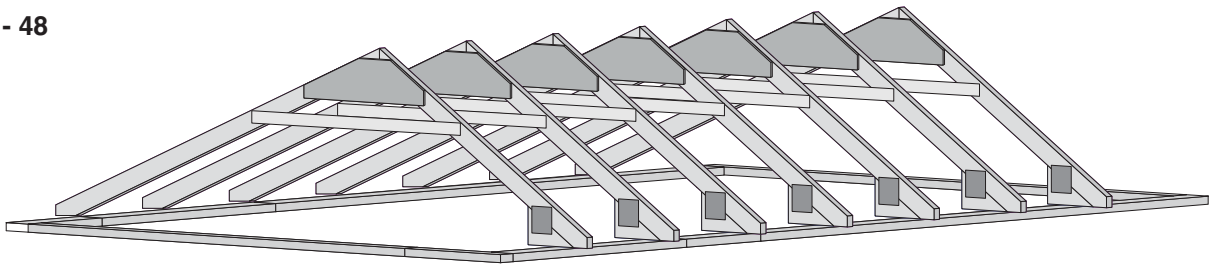

x7

ROOF



3"(7.6 cm) x36

TECHO

Attaching Rafters
(See below for dimensions)

Fijando las vigas
(Ver abajo para las dimensiones)

8'x12' (244 x 366 cm) Shown / Indicado

End Rafters have one gusset to the inside
Las vigas terminales tienen una placa de unión

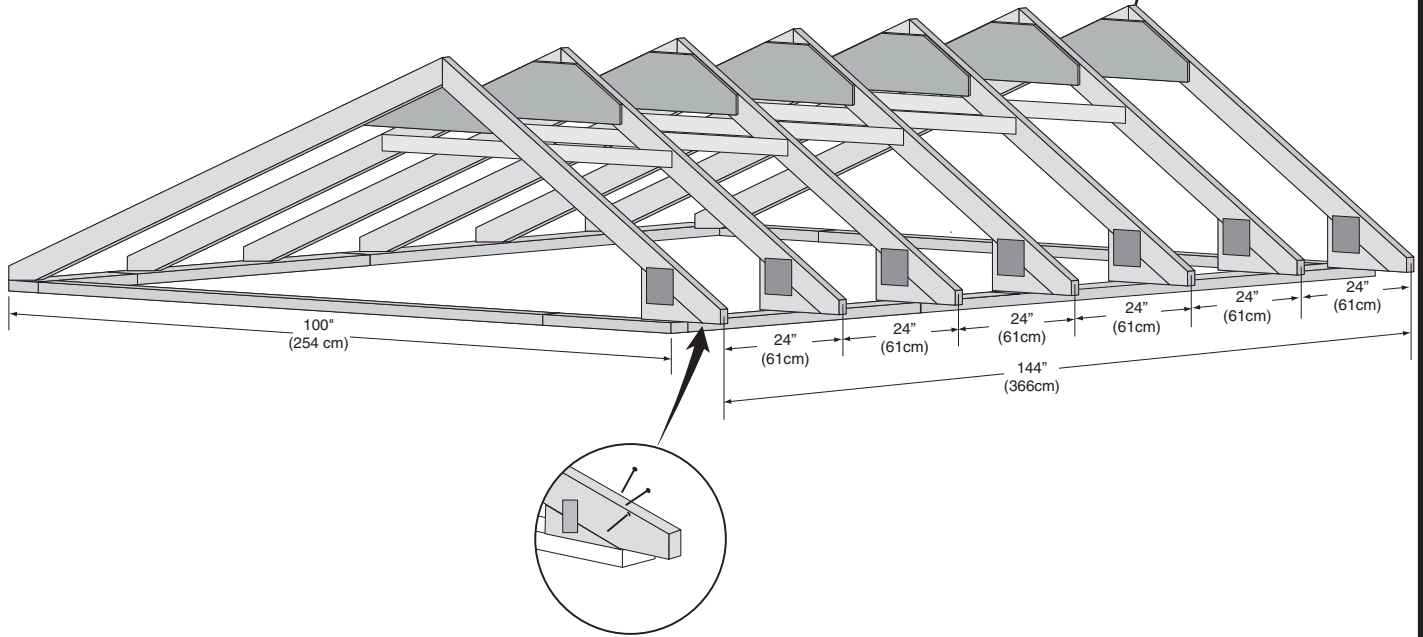

8'x16' (244 x 488 cm)



3"(7.6 cm) x48

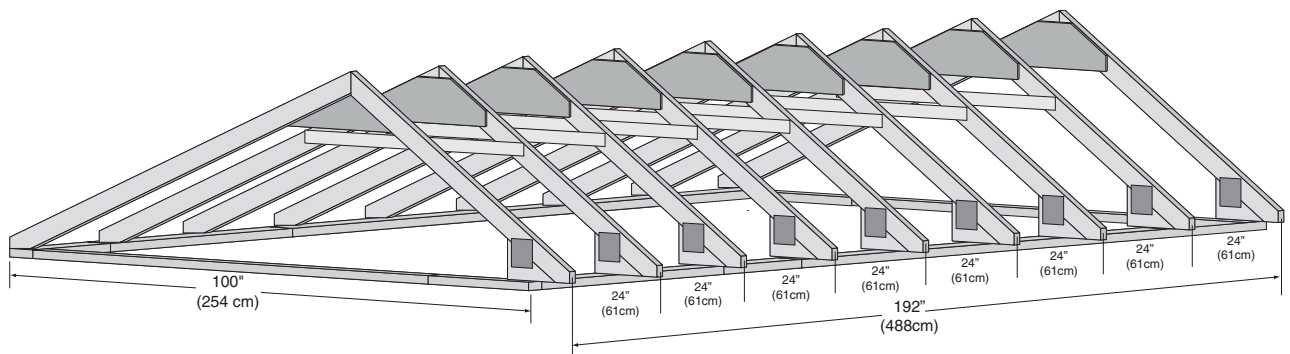

See Page 8 for Building Tip!!!

¡Ver la página 8 para un consejo!

8'x12' (244 x 366 cm) Shown / Indicado

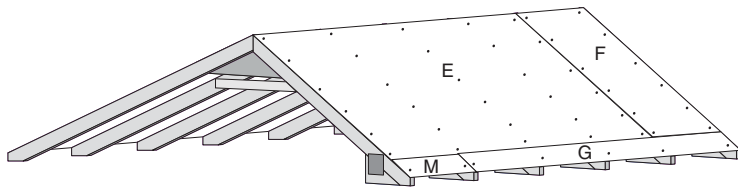
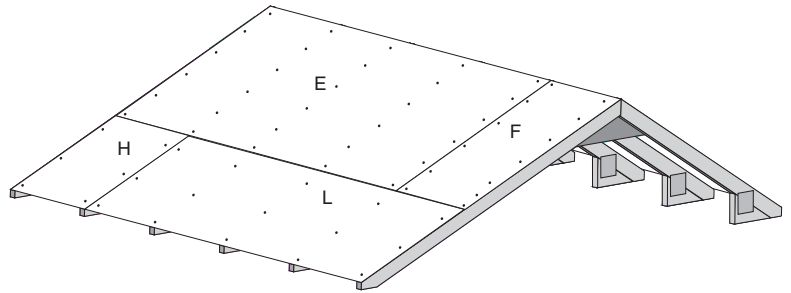

8'x16' (244 x 488 cm)

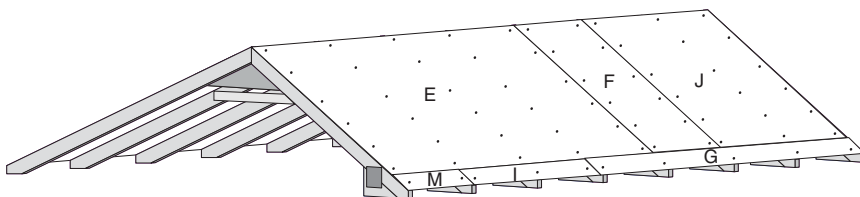
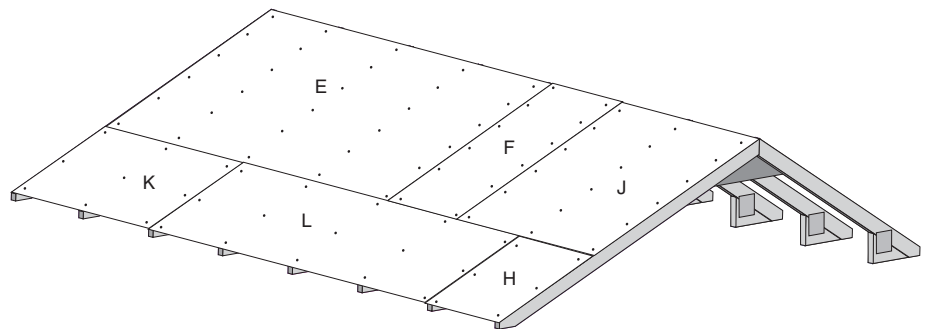

ROOF

1-1/2" (3.8 cm)

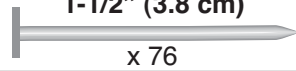

x 76

TECHO

Gable Panels

Paneles del techo a dos aguas

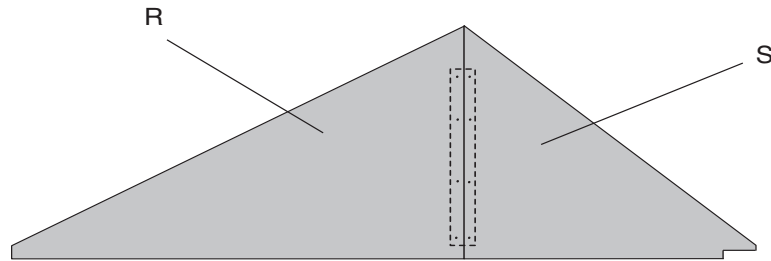
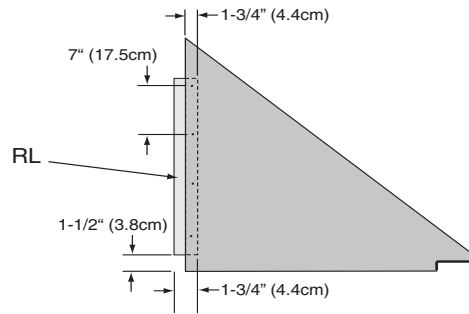

x2

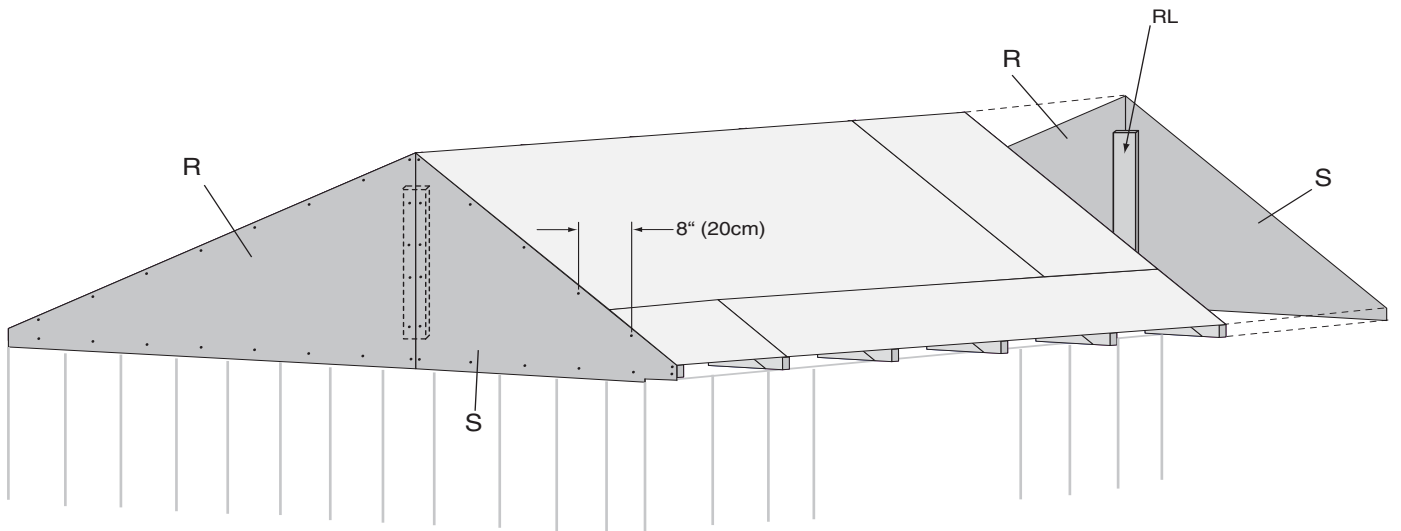

TRIM

2"(5 cm)

MOLDURA

x 21

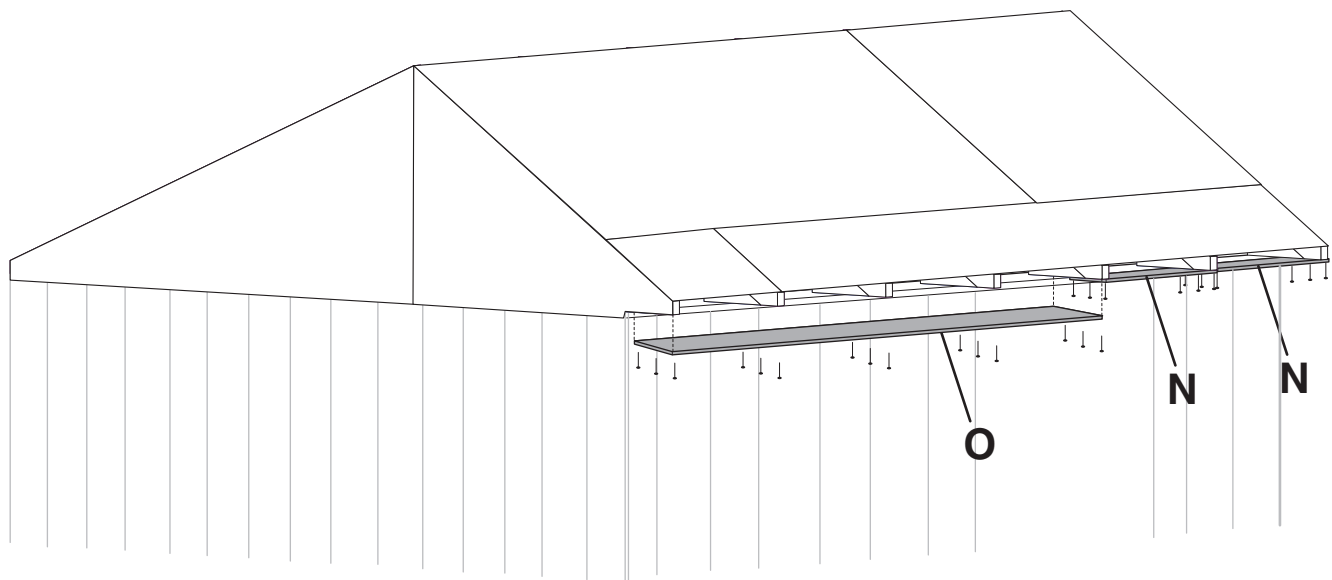

TRIM

2"(5 cm)

MOLDURA

x 66

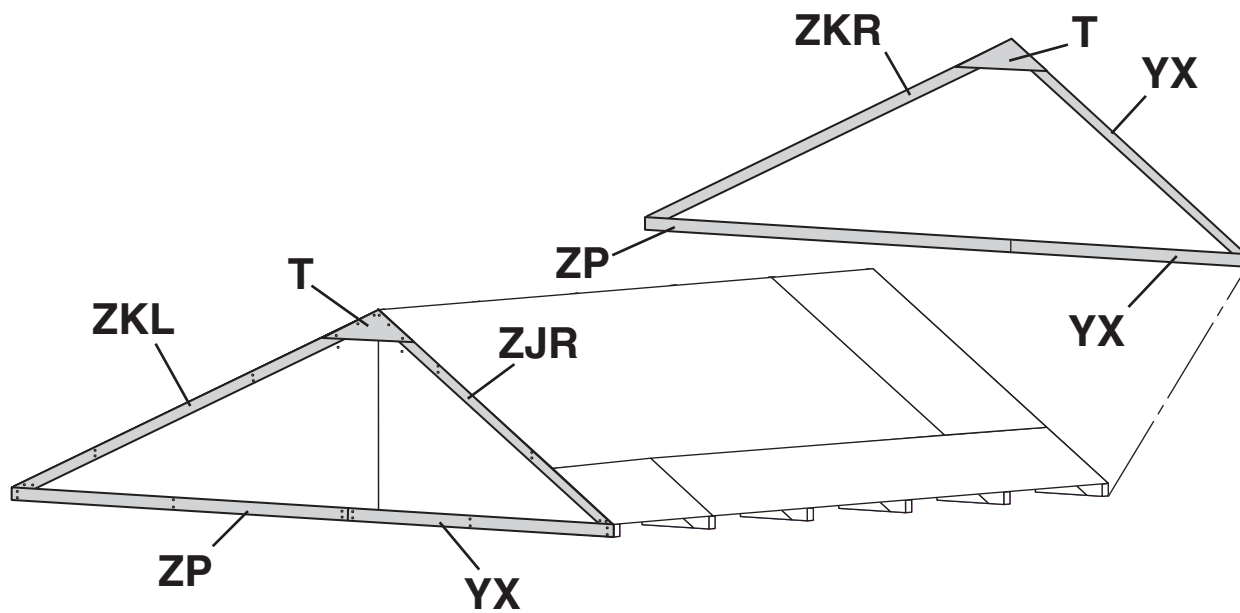

TRIM

2''(5 cm)

x 28

MOLDURA

8'x12' (244 x 366 cm) Shown / Indicado

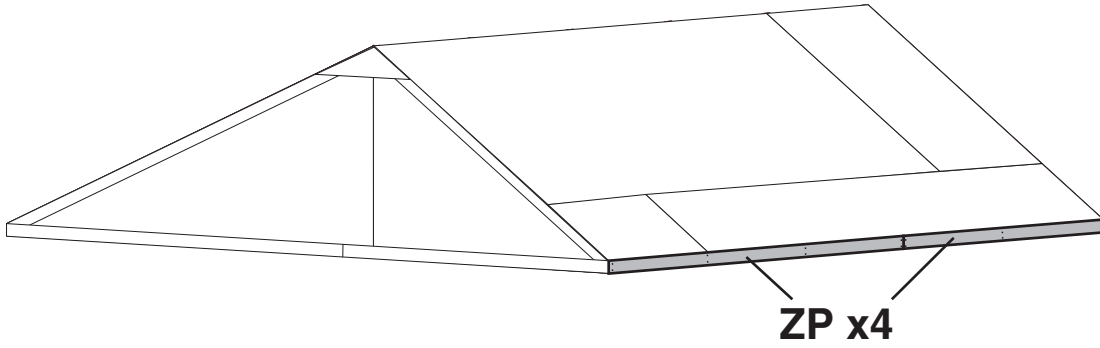

8'x16' (244 x 488 cm)

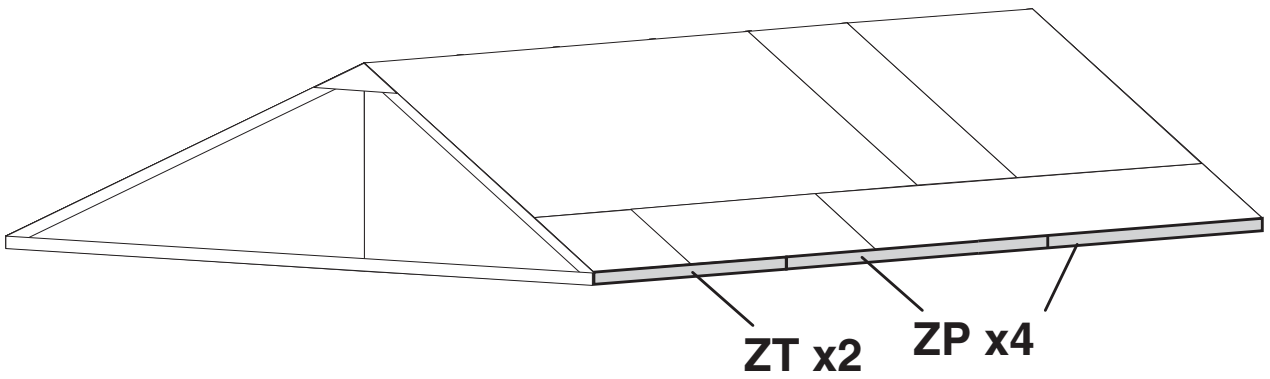

DOOR

1-5/8" (4.1 cm)



PUERTA

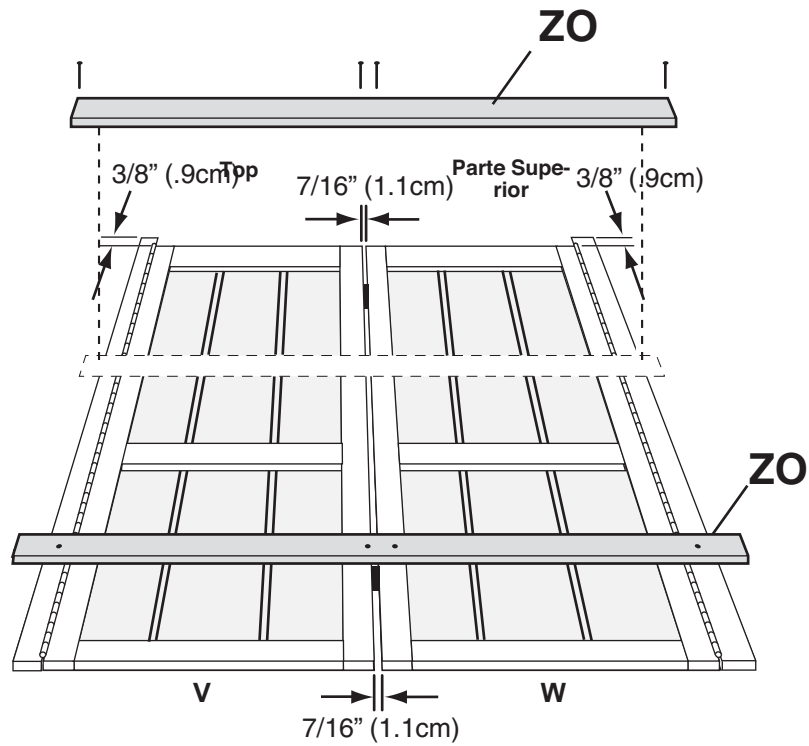

DOOR

3/4" (19 mm)

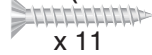

PUERTA

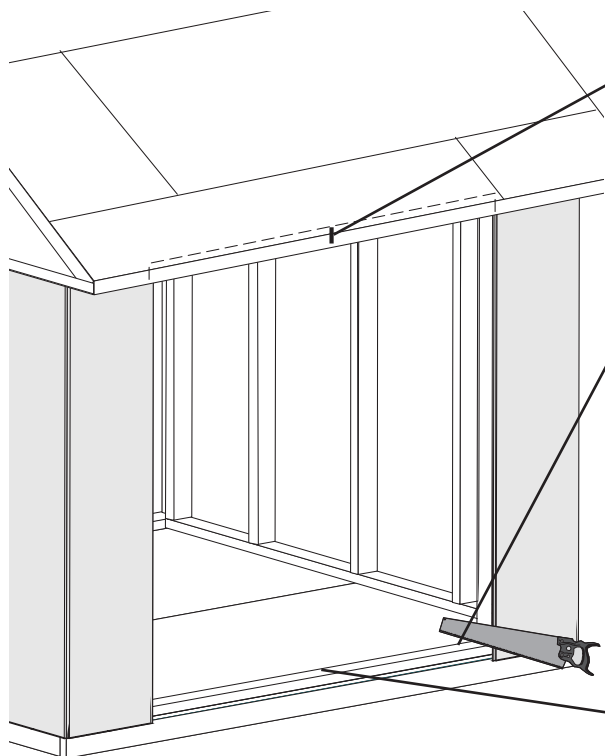

Place a center mark for door location.

Ponga un señal en el centro para la puerta.

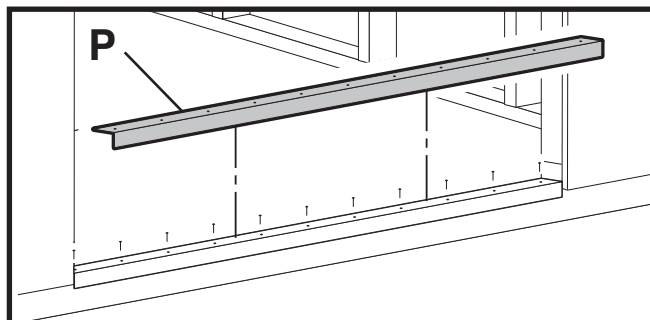

Cut out bottom plate at door opening
Leave treated sill on concrete slab if desired.

Corte la placa inferior en la abertura de la puerta.
Deje la solera tratada en la losa de concreto si quiere.



Install Metal Threshold after cutting bottom plate.
Instalar el Entrada de Metal después de cortar la placa inferior.

DOOR

- A  3" (7.6 cm) x 6
- B  2" (5 cm) x 8
- C  1" (2.5 cm) x 12

PUERTA

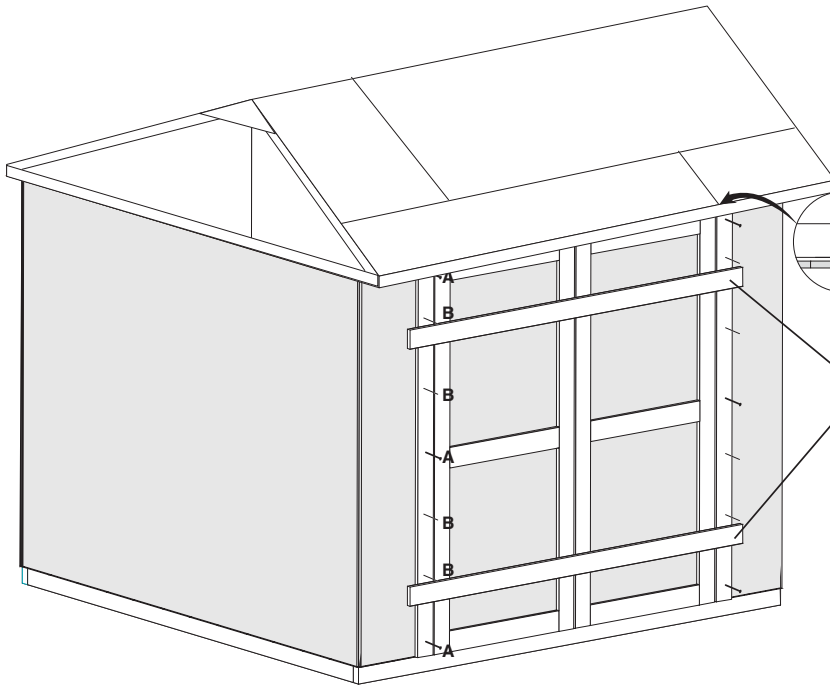

Attach with 3" (7.6 cm) Screws first, check doors to open properly and nail

Fije con tornillos de 3" (7.6 cm) primero, compruebe que las puertas abren bien y clave.

Inside Building
Interior del edificio

Remove after doors are screwed

Quite después de fijar la puerta con tornillos.

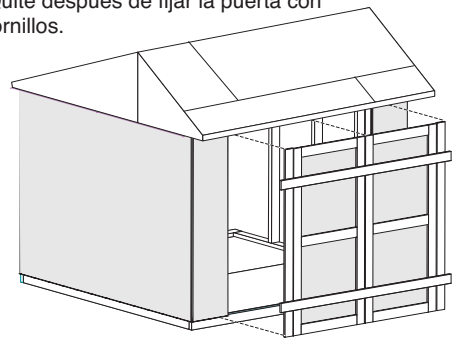

TRIM

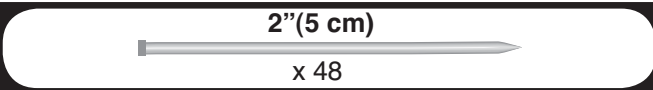

MOLDURA

Do not sink nails completely
No hingue los clavos completamente.

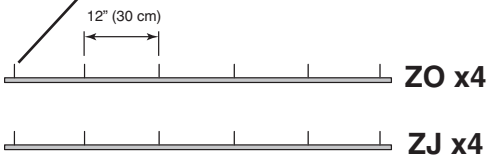

Position trim against underside.

Posicione la moldura contra la parte inferior.

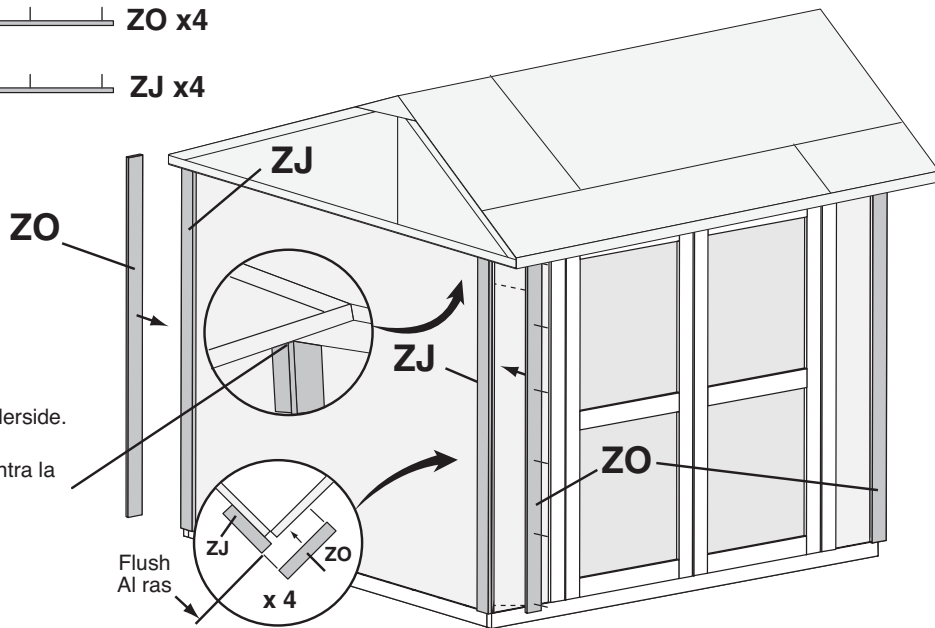

DOOR

PUERTA

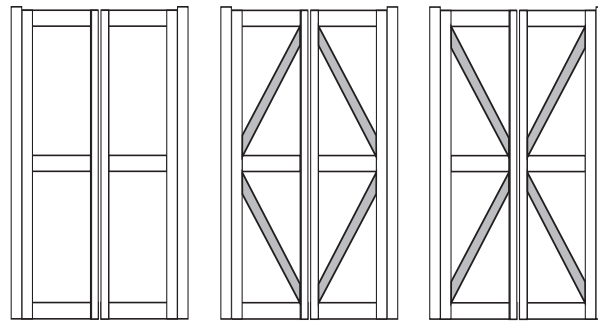
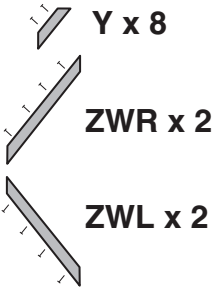

Plain

Diamond

Traditional X

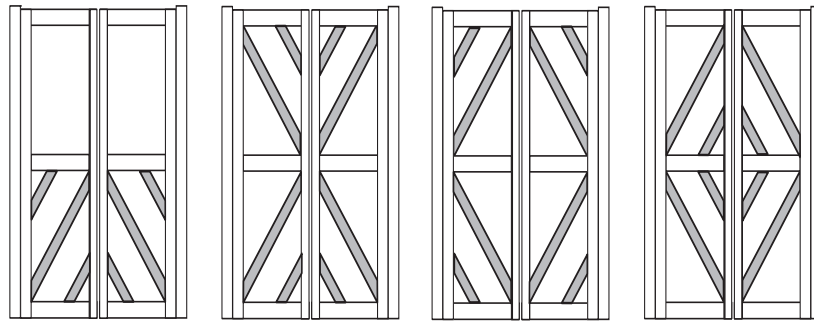

Contemporary

Double X

Outer Diamond

Inner Diamond

DOOR

PUERTA

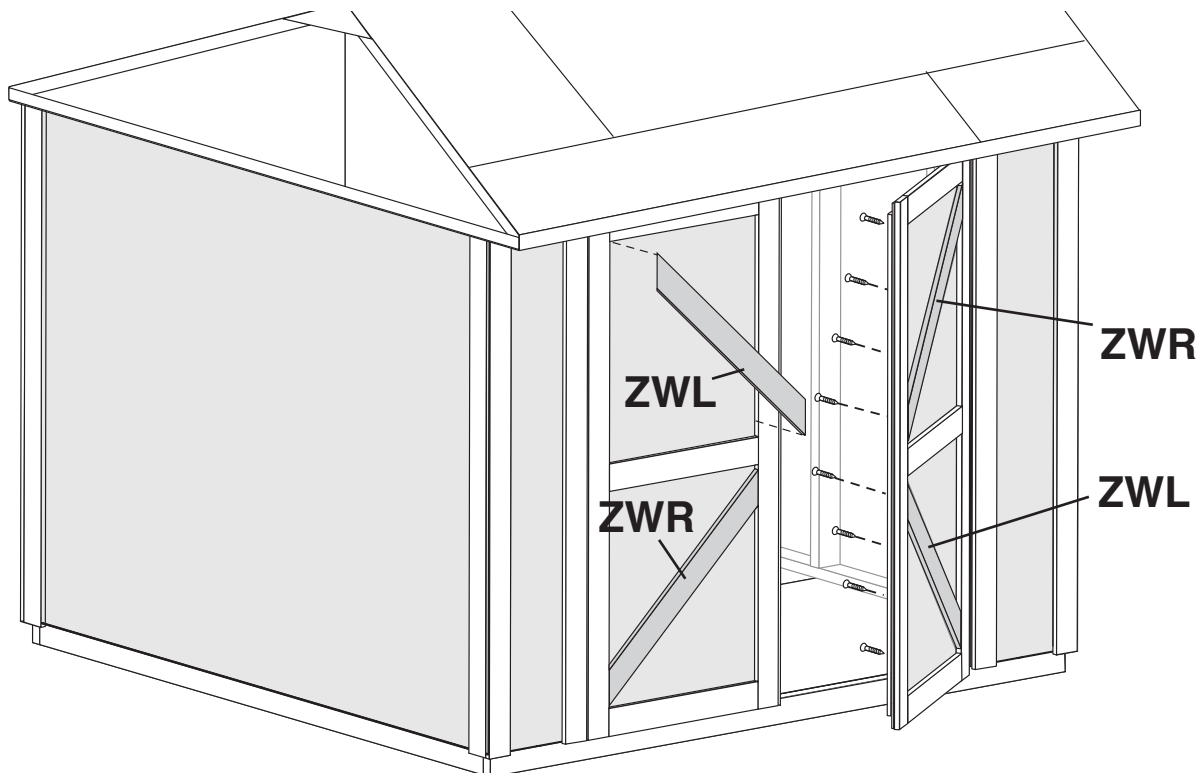
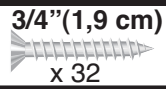

DOOR

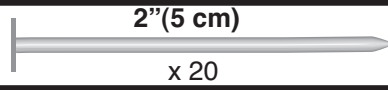
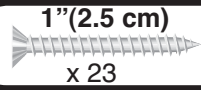

PUERTA

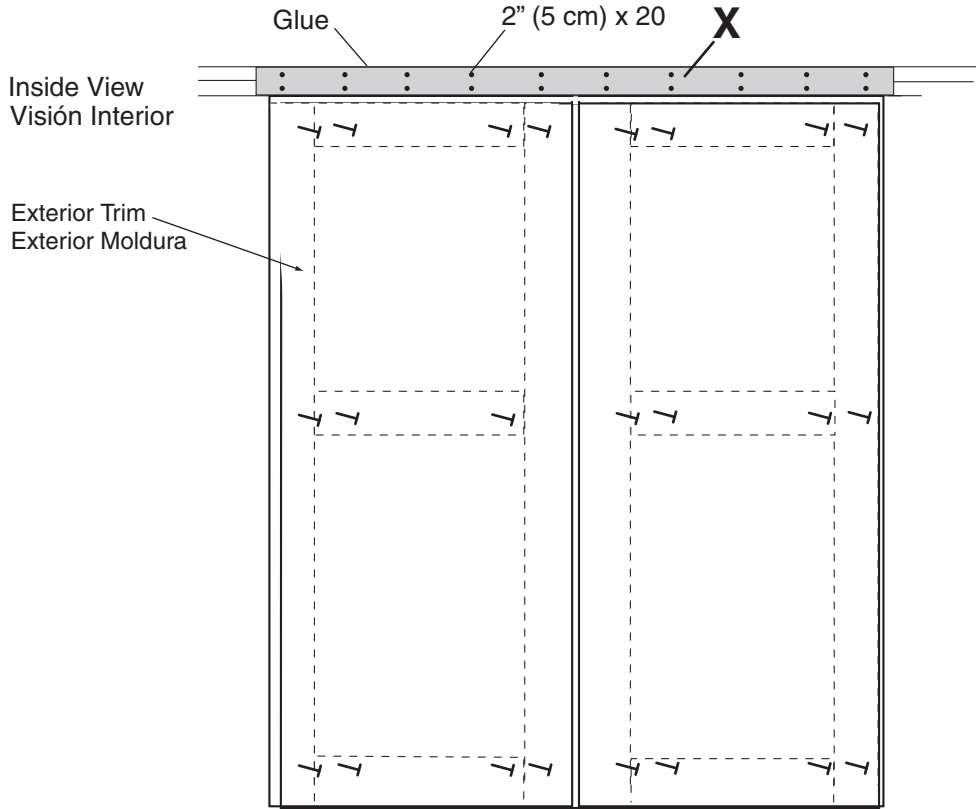

DOOR



PUERTA

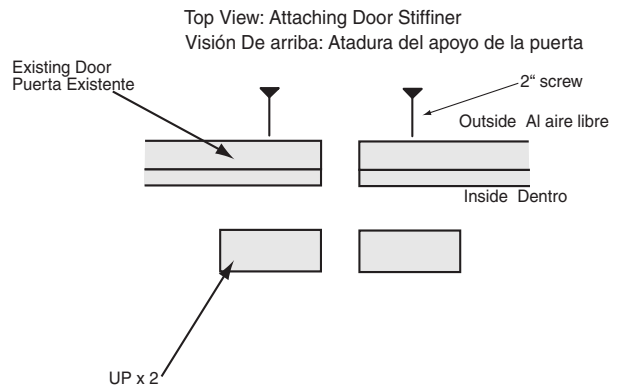
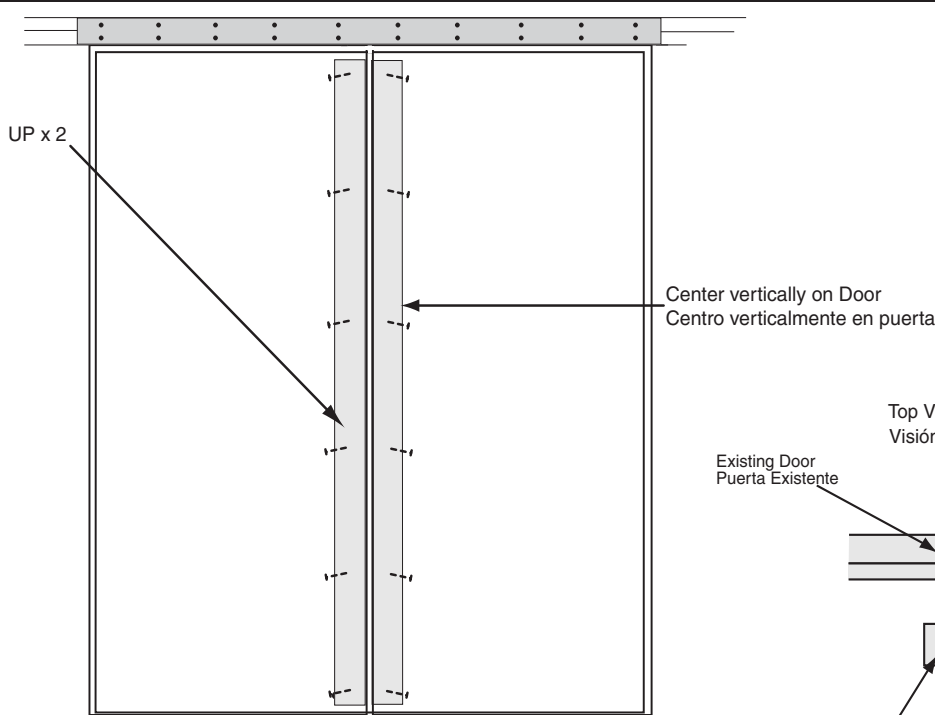

DOOR

1"(2.5 cm)

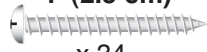

x 34

PUERTA

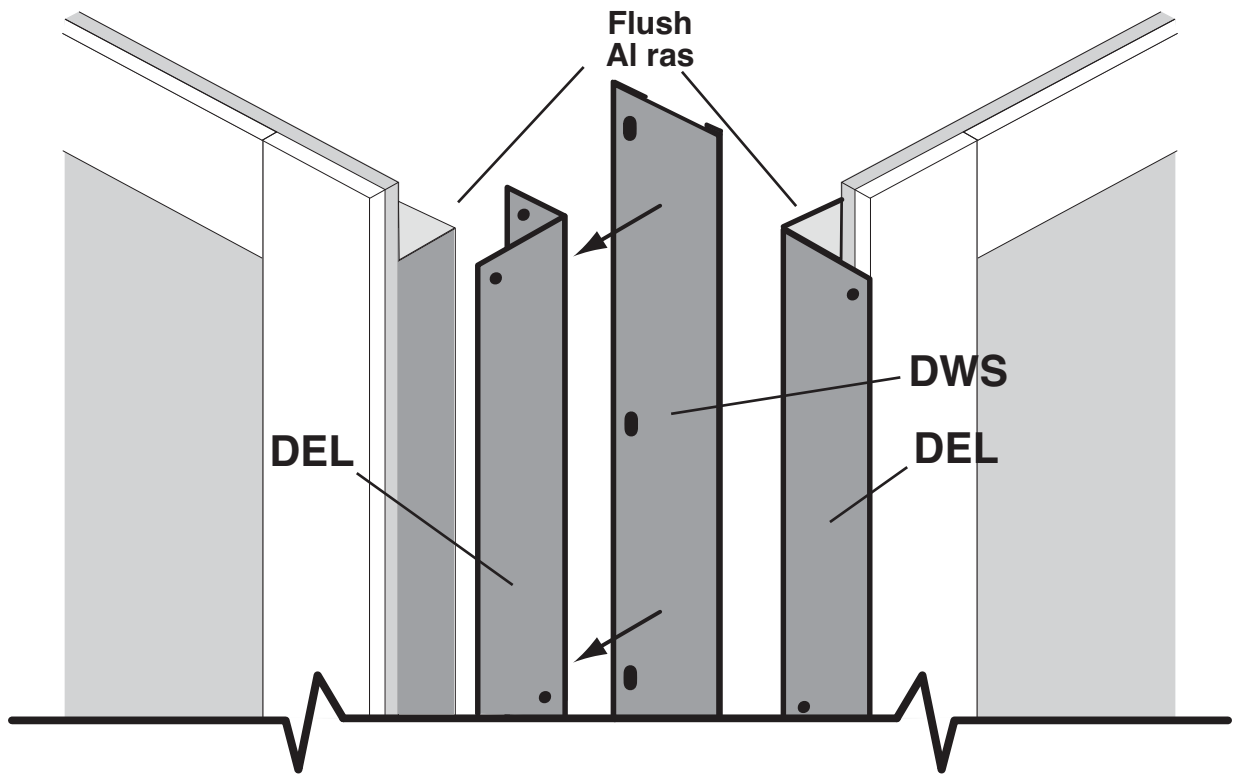
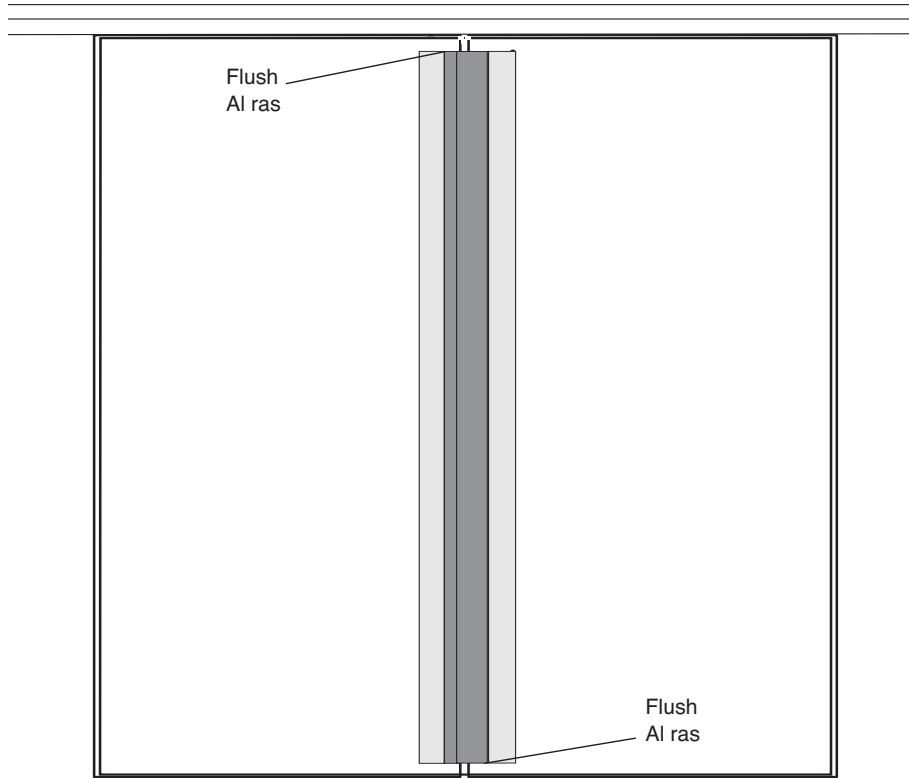

DOOR

PUERTA

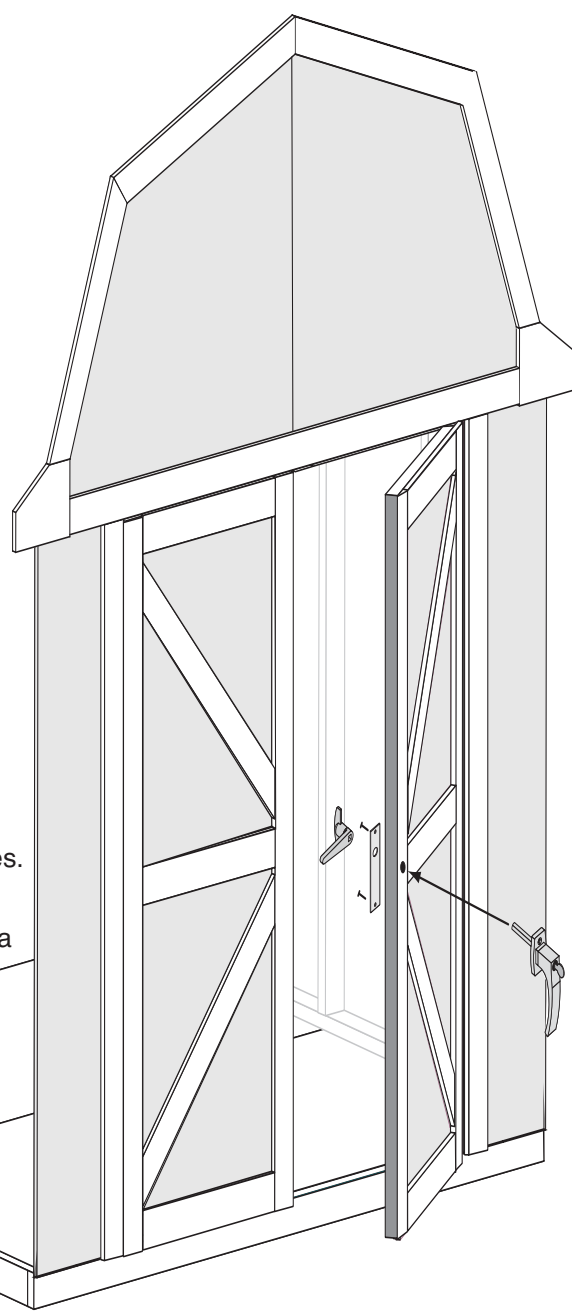
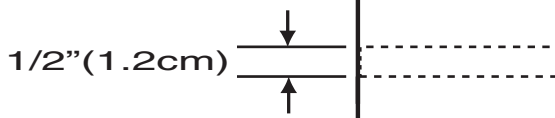
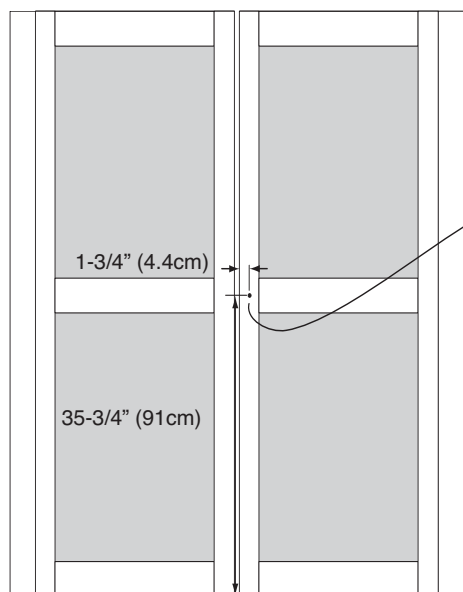

If installing optional 3 point lock refer to the next 2 pages.
If not, skip to page 40.

Si instalando opcional 3 cerradura del punto se refiere a las próximas 2 páginas. Si no, sátese para paginar 40.

OPTIONAL 3 POINT LOCKING MECHANISM

OPCIONAL

See next page for mounting location of brackets and plates
Vea próxima página para montar paréntesis

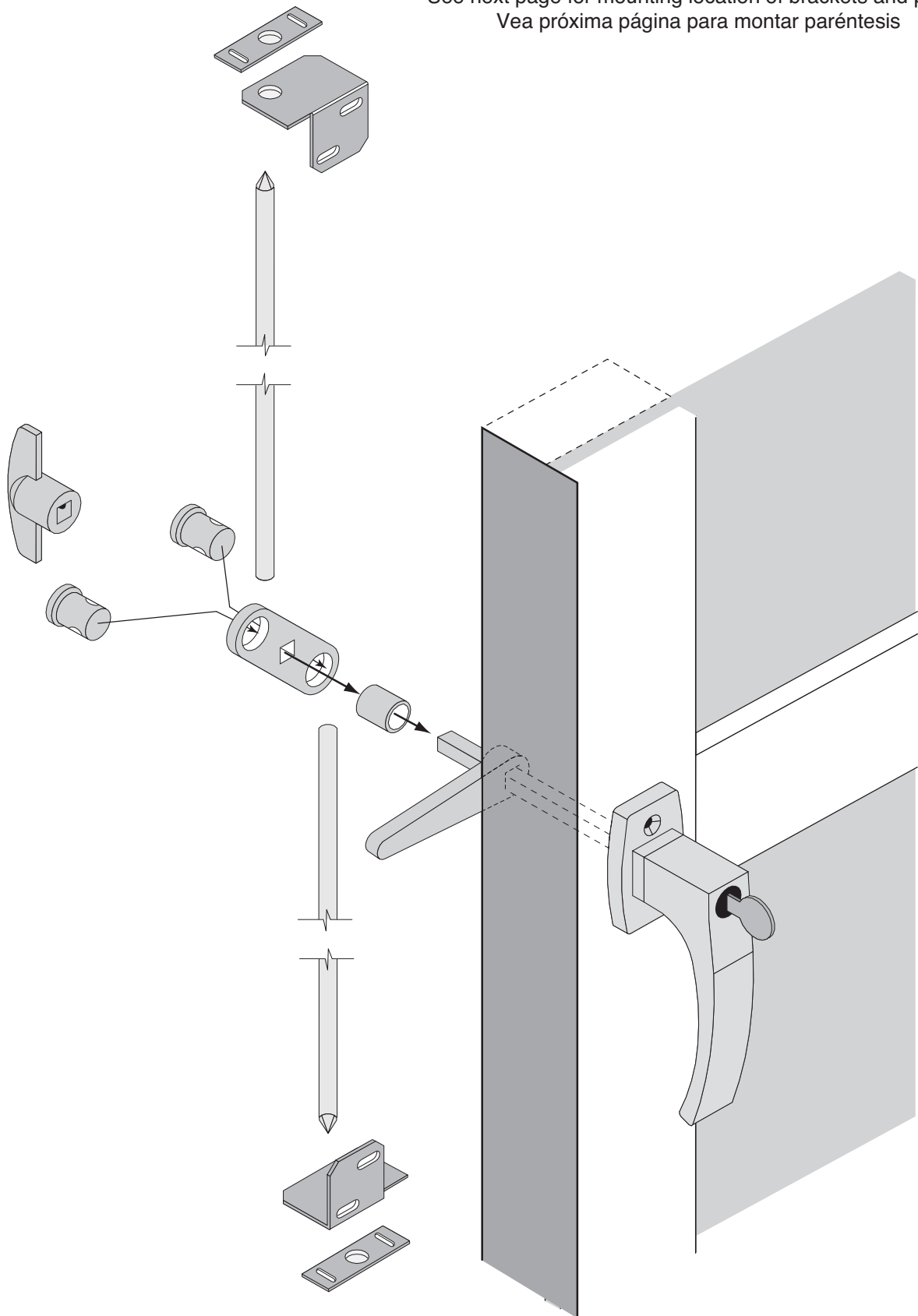

OPTIONAL 3 POINT LOCKING MECHANISM

OPCIONAL

1. Locate exact plate position and mark guide hole
2. Drill a 3/8" hole, 2-1/2" deep going into the header
- 2a. Drill a 3/8" hole through the plywood floor at the bottom
3. Fasten plate with the screws and washers provided

1. Localice la posición exacta de plato y hoyo de guía de marca
2. Taladre un 3/8" hoyo, entrar profundo el hoyo de encabezamiento
- 2a. Taladre un 3/8" hoyo por el piso de contrachapado en el fondo
3. Abroche plato con los tornillos proporcionados

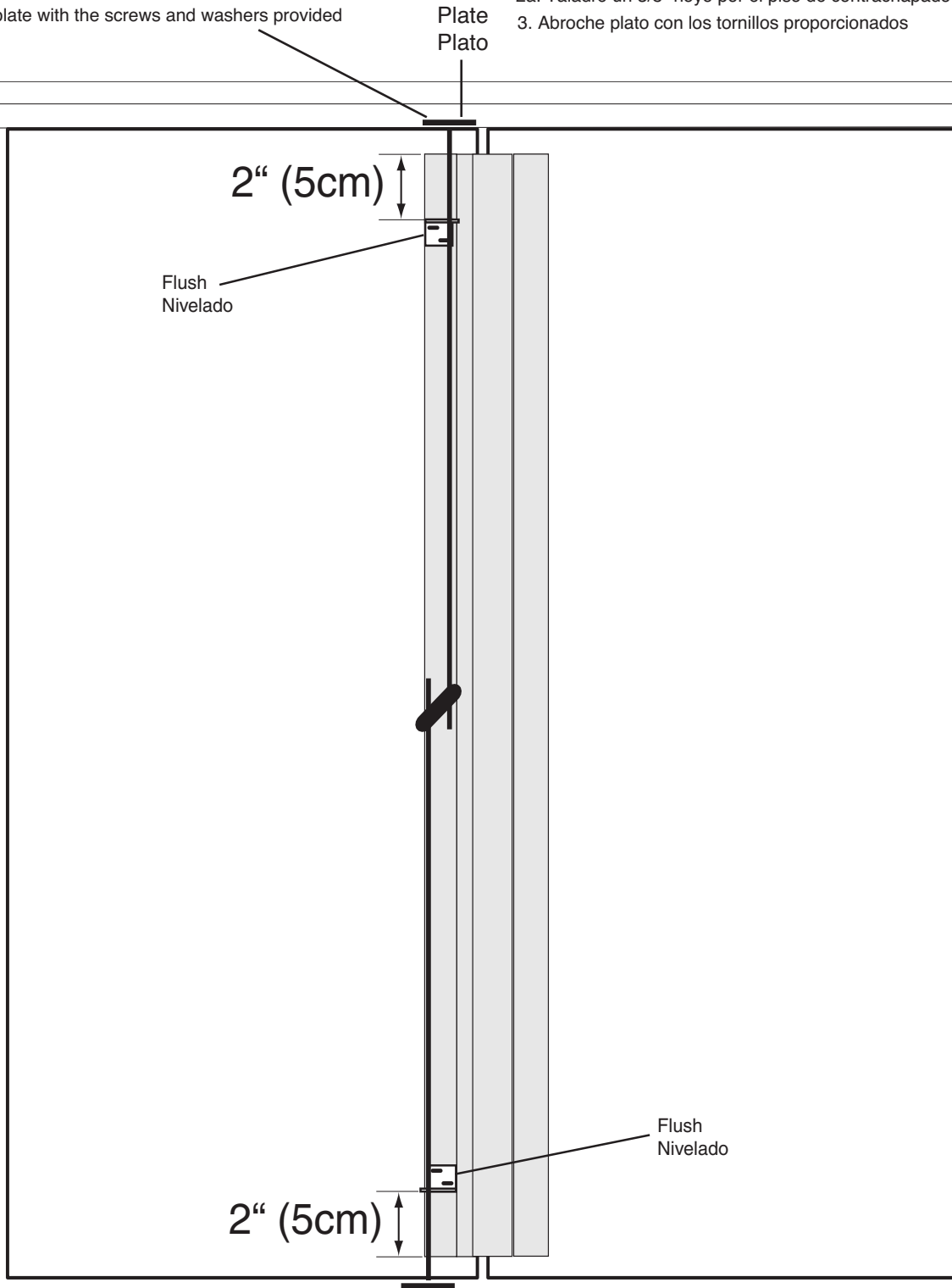

When installing on a concrete slab, drill pilot holes and use green wedge anchors to help secure plate to the concrete.

Al instalar en un trozo concreto, el uso las anclas verdes de la cuña para ayudar plato seguro al suelo

TRIM

3"(7.5 cm)

x 4

MOLDURA

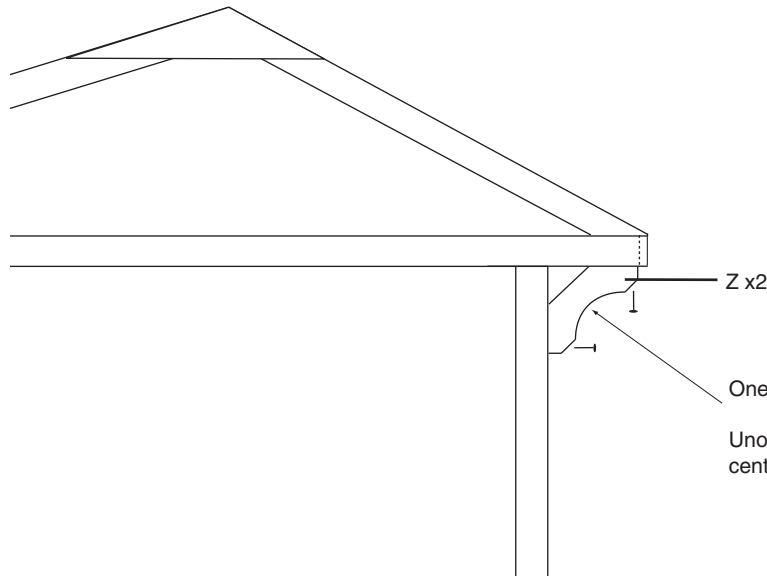

One at each end, centered on trim
Uno en cada extremo del edificio,
centrado en moldura

HOOK AND EYE AND BARREL BOLT

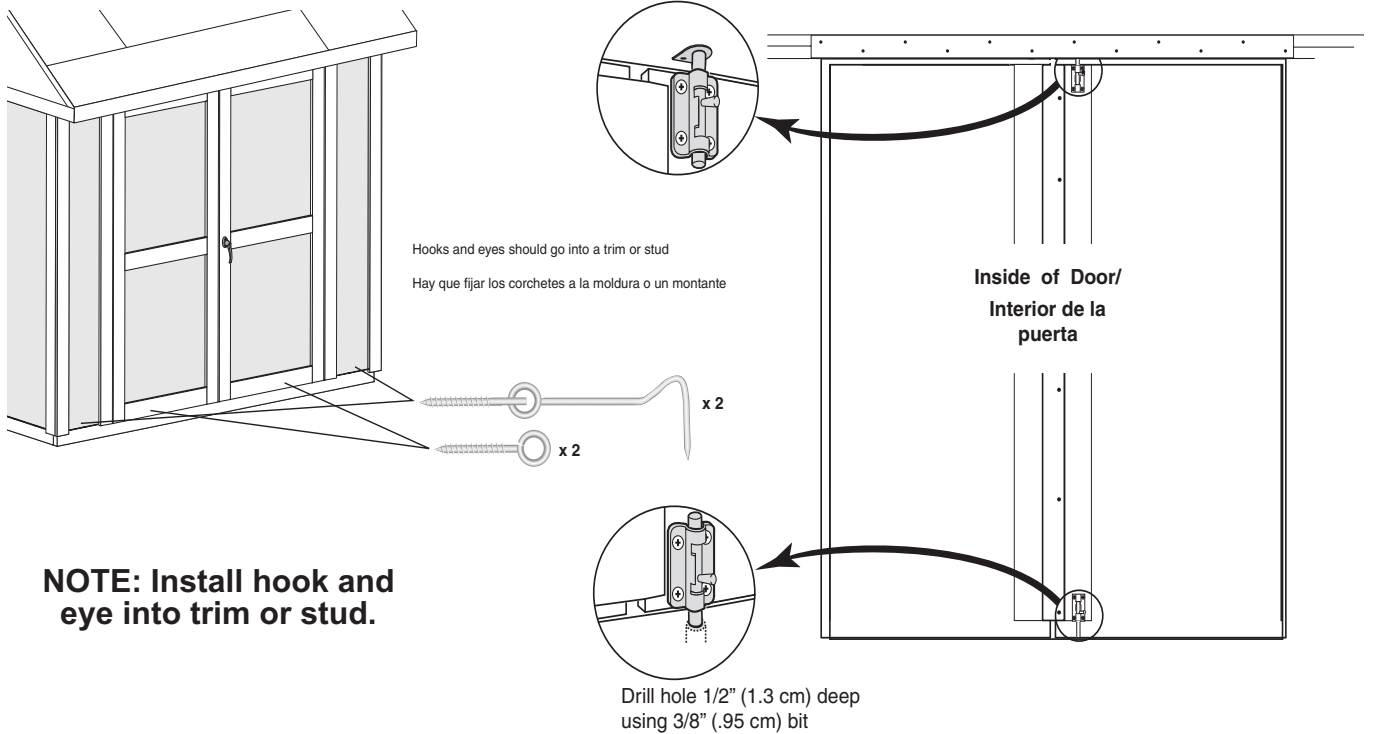

Hooks and eyes should go into a trim or stud
Hay que fijar los corchetes a la moldura o un montante

Inside of Door/
Interior de la
puerta

NOTE: Install hook and eye into trim or stud.

Drill hole 1/2" (1.3 cm) deep
using 3/8" (.95 cm) bit

PAINT AND CAULK (Not Included)

PINTURA Y MASILLADO (No Incluidos)

Use Acrylic Latex Caulk that is paintable. Caulk at all horizontal and vertical seams, between the Trim and Walls, and all around the Door Trim.

Use un masillado acrílico de latex que se puede pintar. Masille todas las juntas horizontales y verticales, entre la moldura y los muros, y alrededor de la moldura de la puerta.

Use a high quality exterior acrylic latex paint. When painting your building, there are a few key areas that can be easily overlooked that **must** be painted:

Use una pintura acrílica de latex de alta calidad. Al pintar su edificio, hay unas areas claves que hay que pintar:

- Bottom edge of all siding and trim
- Inside of doors and all 4 edges

- El borde inferior de toda la cobertura y la moldura.
 - El interior de la puerta y todos los 4 bordes de ésta.
- Aviso: Ponga un imprimador en la madera exterior que no lo tiene antes de pintar.

Note: Prime all un-primed exterior wood before painting

Building Size Dimensiones del edificio	Building Paint pintura del edificio	Trim Paint pintura de moldura	Caulk masillado
8' x 12' (244 x 366 cm)	2 Gallons 2 galones	1 Quart 1 cuartas	2 Tubes 2 tubos
8' x 16' (244 x 488 cm)	2-1/2 Gallons 2-1/2 galones	1 Quart 1 cuartas	2 Tubes 2 tubos

DRIP EDGE (Not Included)

GOTERO DE BORDE (No Incluido)

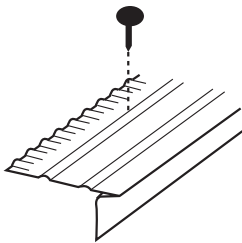

Side that hangs over side No Nails

La parte que está colgada sobre un lado. No clavar.

Snip bottom side of drip edge and Bend over to other side of Roof

Corte la parte inferior del gotero y dóblela sobre el otro lado del techo.

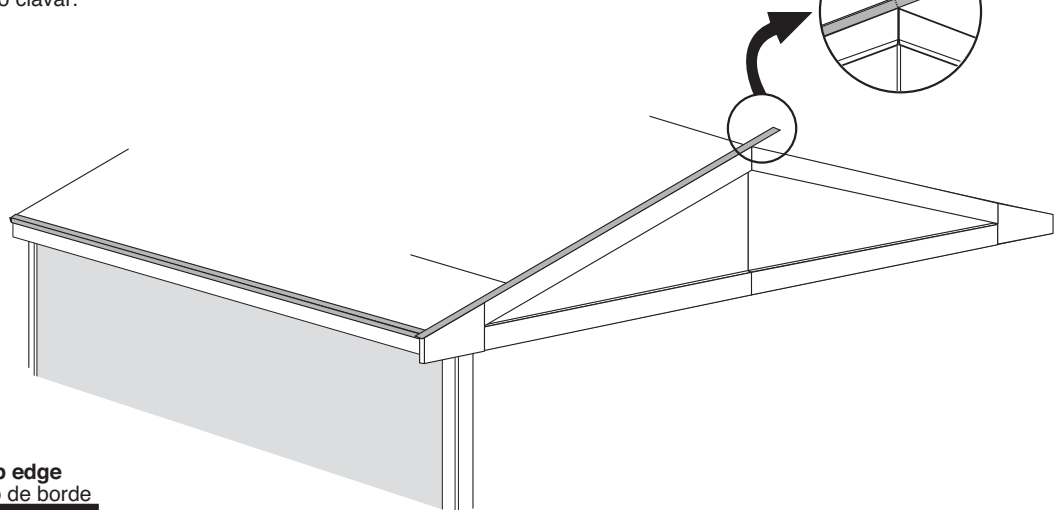
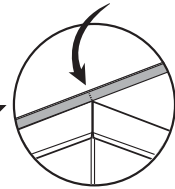

Building Size Dimensiones del edificio	Drip edge Gotero de borde
8' x 12' (244 x 366 cm)	50 feet 50 pies
8' x 16' (244 x 488 cm)	60 feet 60 pies

SHINGLES (Not Included)

TEJAS (No Incluidas)

Building Size Dimensiones del edificio	Shingles Needed Tejas Necesarias
8' x 12' (244 x 366 cm)	5 Bundles 5 bultos
8' x 16' (244 x 488 cm)	7 Bundles 7 bultos

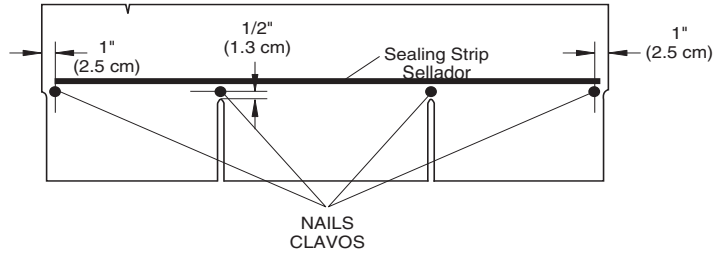

Install first row backwards
Instale la primera fila al revés

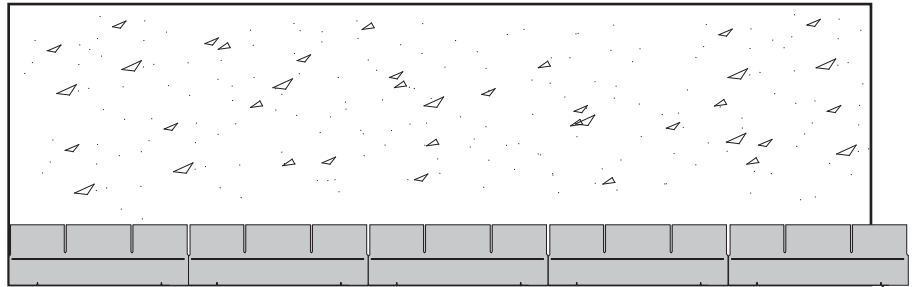

Flush to dripedge
Nivelado al gotero

Okay if Shingle Overlaps
Está bien si la teja sobresale

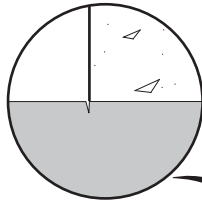

Line up notch on top of Shingle with
edge of Roof to stagger the Shingles

Alinee el corte encima de la teja con
el borde del techo para escalonar las
tejas

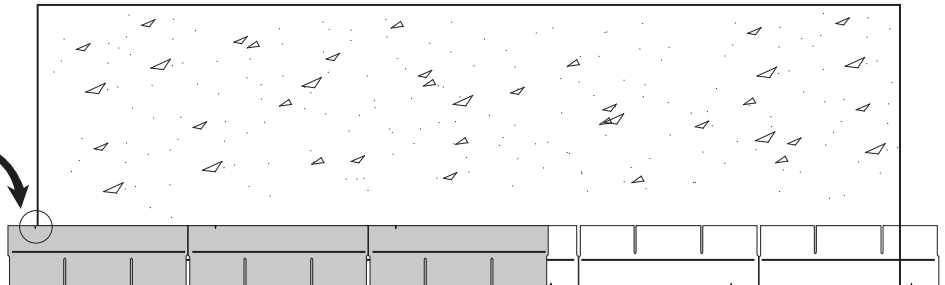

Maintain same dimension across
Mantenga la misma dimensión de un
lado al otro

Flush to edge, stagger each row
Nivele al borde, escalone cada fila

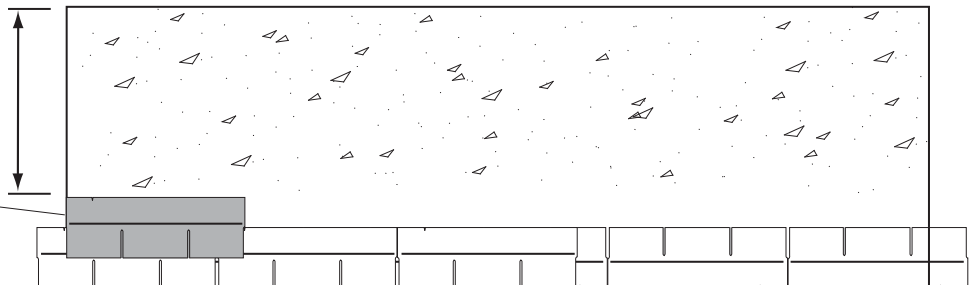

Remove overhanging shingles
Quite tejas sobresalientes

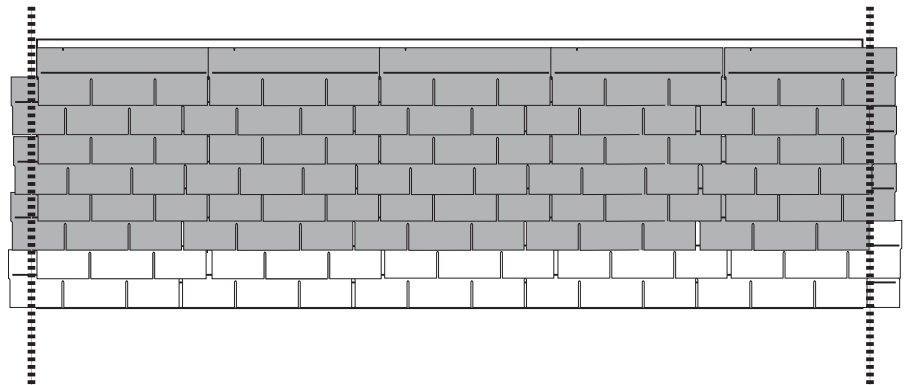

SHINGLES (Not Included)

TEJAS (No Incluidas)

Ridge Cap

tapa de cumbrera

Cut Shingles into 3 pieces
Corte las tejas en tres partes

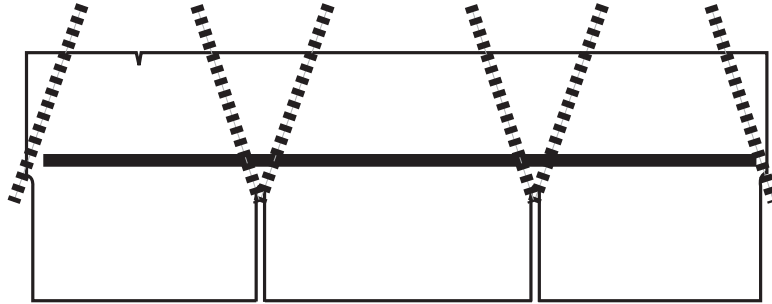

Apply pieces to ridge as shown
Fije las piezas a la cumbrera como en el dibujo

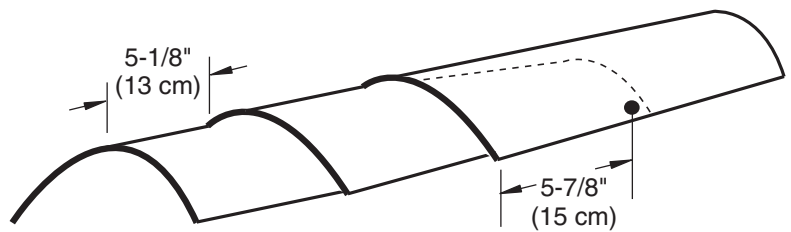

NAIL INSPECTION INSPECCIÓN DE CLAVOS

Check for protruding nails, pound any protruding nails into the wood or cut them off flush.

Inspeccione para clavos sobresalientes; hínque clavos sobresalientes en la madera o córtelos nivelados con la madera.

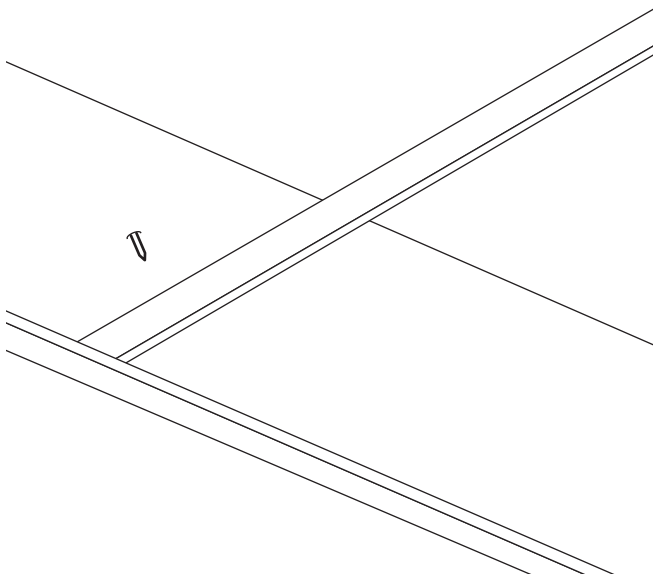

REQUIRED MAINTENANCE MANTENIMIENTO NECESARIO

Keep grass trimmed and away from building
Corte y quite la hierba cerca del edificio

Keep Sprinklers away from building
No use rociadores cerca del edificio

Repaint building every 2 years
Pinte el edificio de nuevo cada dos años

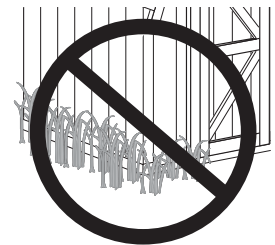

Limited Conditional Warranty

WARRANTY

Your Storage Building, Sunlight Building, Playhouse or Cedar Gazebo is warranted for the following period from date of installation:

- Value Line - 10 year material; 2 year labor.
- Signature Series / Playhouse / Sunlight Building / Vinyl Sided / Cedar Gazebo / Pergola - 10 year material; 5 year labor.
- Garage-sized - 10 year material; 10 year labor.

In the event that your building/structure or a component of your building/structure is found defective, (within the specified warranty period for materials and labor/installation) Backyard Products, LLC will repair, replace, or pay for the affected part. In no event shall Backyard Products, LLC pay the cost for materials, labor/installation beyond the specified warranty stated herein.

CONDITIONS & LIMITATIONS

- Building must be painted using 100% acrylic latex exterior paint, (including the bottom edges of all siding and all four edges and insides of doors) within sixty (60) days of installation. Note: Cedar Gazebos can be finished with a quality, exterior stain (semi-transparent or solid) containing a water repellent and ultra-violet protection.
- Building must be properly maintained, as needed, including, but not limited to, repainting (staining), re-caulking and keeping perimeter and underside of building clear of vegetation.
- Movement of building from its original location or alteration to building may void warranty.
- Damage due to insects, water sprinklers or acts of God (including tornadoes, hail storms, fire, etc.) are not covered.
- This warranty applies to original purchaser only.
- Notice of failure or defect must be reported to Heartland Industries within a reasonable time.

In no event will Backyard Products, LLC be liable for loss or damage to personal property placed in building (including any damage caused by the existence of any defect in building), or for any indirect, incidental, consequential damages nor failure(s) which are caused by events, acts or omissions beyond our control including, but not limited to, misuse or improper maintenance. This warranty gives you certain specific rights which vary from state to state.

REQUIREMENTS

Storage Buildings

To validate your warranty it is necessary to properly maintain your Backyard Products, LLC unit: shingle the roof, and paint or solid-color stain the siding using 100% acrylic latex exterior product with a minimum of two (2) coats within sixty (60) days of installation; caulk above all doors and all horizontal and vertical trim boards; paint and seal all exposed edges, sides and faces of SmartSide™ and waferboard siding to include all exterior walls and all sides and all edges of doors (including the bottom edges of all siding and all four edges and inside of doors). Movement of unit from its original location or alteration to building may void warranty.

Gazebos, Pergolas & Timber Buildings

To validate your warranty it is necessary to properly maintain your Backyard Products, LLC unit. This includes treating all of the exposed cedar and pine surfaces on your gazebo, pergola or timber building with an exterior grade wood preservative, an exterior oil-based semi-transparent stain, an acrylic latex paint or an acrylic latex solid color exterior stain within sixty (60) days of installation and as needed thereafter to maintain your warranty. Note: Cedar structures can be finished with a quality exterior stain (semi-transparent or solid) containing a water repellent and ultra-violet protection. Movement of unit from its original location or alteration to building may void warranty.

Keep vegetation trimmed away from perimeter and underside of building. Make sure siding panels and trim do not come in contact with masonry or cement. The minimum ground clearance for siding must be one half inch (1/2") from concrete slab or two and one half (2-1/2") from the ground when building is erected on a treated wood floor kit. Water from sprinklers must be kept off unit.

CLAIM PROCEDURE

To make a claim under this warranty you can either call 1-888-827-9056 or prepare a letter. Please have ready the information below when you call or include the information when writing:

- Your name, address and telephone number.
- Model and size of the product.
- A list of the part(s) for which the claim is made.
- Proof of purchase of the Backyard Products, LLC item, as shown on the original invoice.
- Run code, as listed on the yellow warranty card enclosed in the product package.

Mail your warranty claim to:

Backyard Products, LLC
Attn.: Customer Service
1000 Ternes Drive
Monroe, MI 48162

***WARRANTY TERMS MAY VARY OUTSIDE THE U.S.A.**

IMPORTANT: This is your warranty certificate.

Please complete and mail your warranty card to properly validate your warranty.

LDR: 05/21/08 PL

GARANTÍA

El cobertizo de almacenamiento, el invernadero, la casita de niños o el kiosco de cedro tienen garantía por los siguientes períodos, a partir de la fecha de instalación:

- Línea Value - 10 años por los materiales; 2 años por la mano de obra
- Serie Signature / casita de niños / invernadero / revestimiento de vinilo / kiosco de cedro / pérgola - 10 años por los materiales; 5 años por la mano de obra
- Tamaño garaje - 10 años por los materiales; 10 años por la mano de obra

En caso de que la construcción, la estructura o un componente de la construcción o de la estructura presente un defecto, (dentro del plazo especificado por la garantía para materiales y mano de obra a partir de la instalación) Backyard Products, LLC reparará, reemplazará o pagará la parte afectada. En ningún caso Backyard Products, LLC pagará el costo de materiales, mano de obra o instalación más allá de la garantía aquí establecida.

CONDICIONES Y LIMITACIONES

- El edificio debe ser pintado utilizando una pintura 100% látex acrílica para exteriores, (incluidos los bordes inferiores de todos los revestimientos y los cuatro bordes interiores de las puertas) dentro de los sesenta (60) días de la instalación. Nota: Los kioscos de cedro pueden terminarse con un barniz para exteriores de calidad (semi transparente o de color) resistente al agua y a los rayos ultravioletas.
- El edificio debe ser adecuadamente mantenido, según sea necesario, incluido, pero sin limitarse a ello, repintar (barnizar), remasillar y mantener el perímetro y la parte inferior de la construcción libre de vegetación.
- El traslado del edificio de su ubicación original, o cualquier alteración al mismo, anularán la garantía.
- Los daños debidos a insectos, agua de los aspersores o actos de Dios (incluidos tornados, granizadas, incendios, etc.) no están cubiertos.
- Esta garantía sólo es válida para el comprador original.
- Se debe notificar a Heartland Industries de las fallas o defectos dentro de un plazo razonable.

En ningún caso se hará responsable a Backyard Products, LLC por la pérdida o los daños a objetos personales contenidos en el edificio (incluido cualquier daño causado por la existencia de cualquier defecto de la construcción), ni por cualquier daño indirecto, incidental o consecuente, ni por falla(s) provocada(s) por eventos, actos u omisiones fuera de nuestro control, incluido, entre otros, uso indebido o falta de mantenimiento. Esta garantía le brinda ciertos derechos específicos que varían de un estado a otro.

REQUISITOS

Cobertizos de almacenamiento

Para validar la garantía es necesario que mantenga correctamente su unidad de Backyard Products, LLC: colocarle las tejas al techo, pintar o barnizar el revestimiento utilizando un producto 100% látex acrílico para exteriores con un mínimo de dos (2) capas, dentro de los sesenta (60) días de la instalación; masillar sobre todas las puertas y todas las molduras horizontales y verticales; pintar y sellar todos los bordes expuestos, lados y caras del revestimiento SmartSide™, y del revestimiento de tableros para incluir todas las paredes exteriores y todos los lados y bordes de puertas (incluidos los bordes inferiores de todos los revestimientos y los cuatro bordes y las caras interiores de las puertas). El traslado de la unidad de su ubicación original, o cualquier alteración a la misma, anularán la garantía.

Kioscos, pérgolas y construcciones de madera

Para validar la garantía es necesario que mantenga correctamente su unidad de Backyard Products, LLC. Esto incluye el tratamiento de todas las superficies expuestas de cedro y de pino en su kiosco, pérgola o construcción de madera, con un conservante para madera, un barniz semitransparente de base oleosa para exteriores, una pintura látex acrílica o un barniz látex acrílico de color para exteriores, dentro de los sesenta (60) días de la instalación y según sea necesario en adelante, para mantener la garantía. Nota: Las estructuras de cedro pueden terminarse con un barniz para exteriores de calidad (semi transparente o de color) resistente al agua y a los rayos ultravioletas. El traslado de la unidad de su ubicación original, o cualquier alteración a la misma, anularán la garantía.

Mantener recortada la vegetación próxima al perímetro y a la parte inferior de la construcción. Asegúrese de que los paneles de revestimiento y las molduras no entren en contacto con la mampostería y el cemento. La holgura mínima entre el suelo y el revestimiento debe ser de media pulgada (13 mm) si es una base de concreto, o de dos pulgadas y media (6,4 cm) cuando se construye el edificio sobre un base de madera con un equipo de madera tratada. No debe mojarse la unidad con el agua de los aspersores.

PROCEDIMIENTO DE RECLAMO

Para realizar un reclamo bajo esta garantía, puede llamar por teléfono al 1-888-827-9056 o escribir una carta. Tenga preparada la información mencionada a continuación cuando llame o incluya la información por escrito:

- Su nombre, dirección y número telefónico.
- El modelo y tamaño del producto
- Una lista de las partes por las cuales está haciendo el reclamo.
- Comprobante de compra del producto de Backyard Products, LLC, según se muestra en la factura original.
- Código de serie, como aparece en la tarjeta amarilla de garantía incluida en el paquete del producto.

Envíe por correo el reclamo de garantía a:

Backyard Products, LLC
Attn.: Customer Service
1000 Ternes Drive
Monroe, MI 48162

***LAS CONDICIONES DE LA GARANTIA PUEDEN VARIAR FUERA DE ESTADOS UNIDOS
IMPORTANTE: Esta página es su certificado de garantía.
Favor de llenar completamente y enviar la tarjeta de garantía para dar validez a la garantía.**

LDR: 05/21/08 PL