

The Luxury of Outdoor Living



Theon Antique Bronze 3pc Bistro Set

Item#: 62696



ATTACH YOUR RECEIPT HERE

Keep a copy of your proof of purchase or order confirmation which will be needed if you need to contact us about warranty coverage.

Purchase Date: _____



SAVE THESE INSTRUCTIONS FOR FUTURE REFERENCE.



Questions, problems, missing parts?

Before returning to your retailer, our exceptional customer service is available.

Call us toll-free at (866) 985-7877, email us at cservice@welltraveled.net, or go online and live chat at www.wtliving.com. Our hours are: 9 a.m. – 6 p.m., EST, Monday – Friday



BEFORE YOU BEGIN

Before beginning assembly, make sure all parts are present. Compare parts received with the "Parts List." If any part is missing or damaged, do NOT attempt to assemble the product. Please read and understand this entire manual before attempting to assemble, operate or install this product. If you have any questions regarding the product, please call us toll-free at **(866) 985-7877**, email us at **cservice@welltraveled.net**, or go online and live chat at **www.wtliving.com**. Our hours are: **9 a.m. – 6 p.m., EST, Monday – Friday**



GENERAL INFORMATION

Your new patio furniture is made from the finest materials available. It should provide many years of enjoyment with minimal care.

Keep your patio furniture clean and apply a coat of wax a few times a year. For best results, clean the patio furniture with warm soapy water and use an outdoor furniture wax. If you use furniture covers, always make sure the furniture is clean and completely dry before covering as mold may form in dark, wet places. Check the bolts on your patio furniture regularly to make sure they are tight.

To provide a rust free product this patio furniture is made of Cast Aluminum which is a relatively soft material. Be careful not to overtighten your hardware. Stripped hardware is not covered under the manufacturer's warranty. The weight limit for each seat is 225 lbs.



SAFETY INFORMATION

WARNING

DO NOT stand or allow children to stand on the assembled product. DO NOT tighten bolts completely until instructed to do so. After final alignment, make sure all nuts and bolts are securely fastened. NEVER use a power tool to assemble or tighten your furniture. Perform periodic checks to make sure the hardware is secure and tighten if needed.

CAUTION

READ all instruction before beginning assembly. Failure to do so may result in faulty assembly and potential injury. Assemble the items on a soft, non-abrasive surface such as a carpet or cardboard to avoid damaging the item.

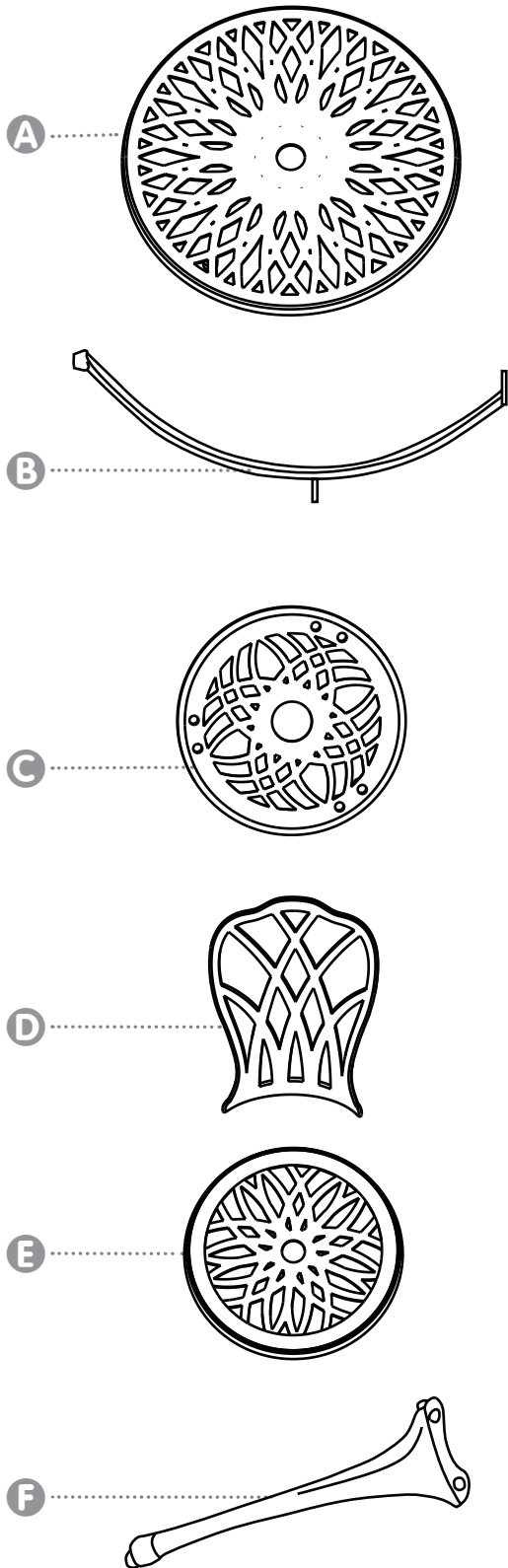

PART	DESCRIPTION	QUANTITY
A	Table Top	1
B	Table Leg	3
C	Leg Brace	1
D	Backrest	2
E	Seat	2
F	Chair Leg	8



HARDWARE CONTENTS

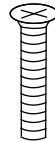

G

6x35mm Bolt
Qty: 7
(6 for assem +1 extra)

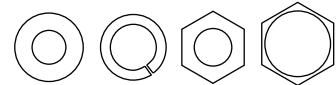

H

Washer/Spring Washer /Nut/Plastic Cap (8mm)
Qty: 24
(23 for assem +1 extra)

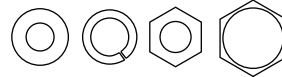
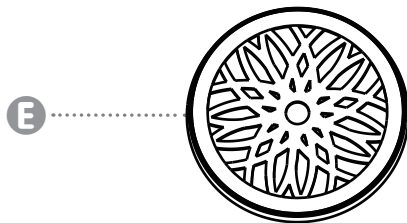
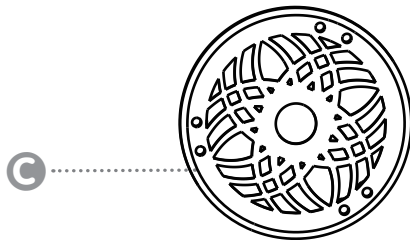

I

Washer/Spring Washer /Nut/Plastic Cap (6mm)
Qty: 7
(6 for assem +1 extra)



J

Stud (8x30mm)
Qty: 4
(3 for assem +1 extra)

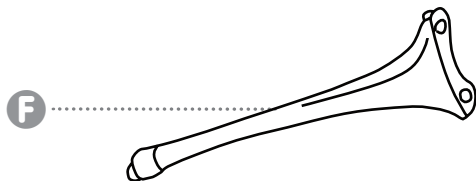

K

Wrench
Qty: 1



PREPARATION

Before beginning assembly, be sure to empty contents of carton and make sure all parts are present. If any parts are missing, please contact Customer Service at (866)-985-7877, Monday-Friday, 9 a.m. - 6 p.m. EST or email at cservice@welltraveled.net.

Place all parts on a soft, level surface for assembly. Estimated Assembly Time: 30 Minutes | DO NOT over tighten hardware!
You will need a Phillips head screwdriver for assembly.

TABLE ASSEMBLY

- 1 Lay the **Table Top A** upside down on a clean, soft, level surface.
Screw 3 **Studs I** into the threaded holes on the bottom of the **Table Top**.



Hardware: **I Stud (8x30mm) x 3**

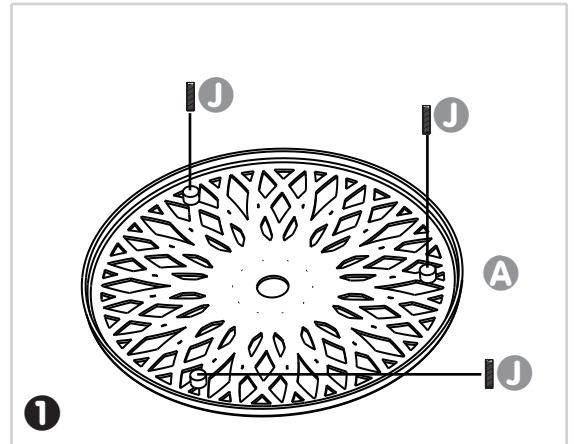

- 2 Fit a **Table Leg V** over one of the **Studs I** and secure in position by sliding a **Washer/Spring Washer H** over the **Stud**, then fastening with a **Nut G**. Tighten with the **Wrench K**, then cover the **Nut** with a **Plastic Cap H**.

Repeat to install the other two **Legs**.



Hardware: **G Washer/Spring Washer/Nut/Cap (8mm) x 3**

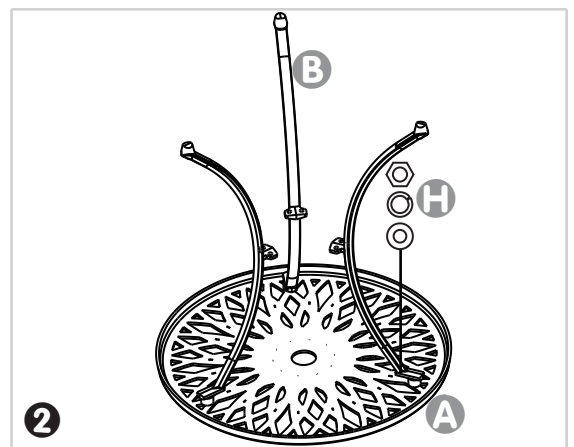

- 3 Carefully turn the assembled **Table Top/Legs** upright.
Align the bolt holes on the **Leg Brace C** with the brackets on the **Legs B** and insert a **Bolt G** in each hole. Secure each **Bolt** by sliding on a **Washer/Spring Washer I** and fastening with a **Nut I**. Tighten all **Bolts** and **Nuts** securely, but do not overtighten. Cover each **Nut** with a **Plastic Cap I**.



Hardware: **G Bolt (6x35mm) x 6**

I Washer/Spring Washer/Nut/Cap (6mm) x 6

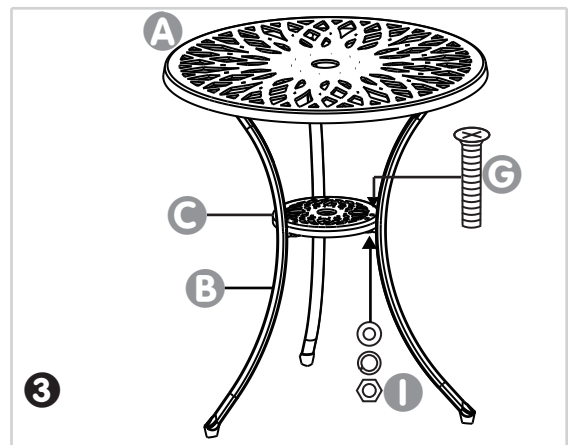

CHAIR ASSEMBLY

4 Attach the **Backrest D** to the **Seat E** by inserting the pre-installed studs on the **Backrest** into the two holes on the **Seat**. Secure with a **Washer/Spring Washer/Nut** on each stud. Tighten securely but do not overtighten.

Repeat to begin assembling second chair.

Hardware: **Washer/Spring Washer/Nut/Cap (8mm) x 4**

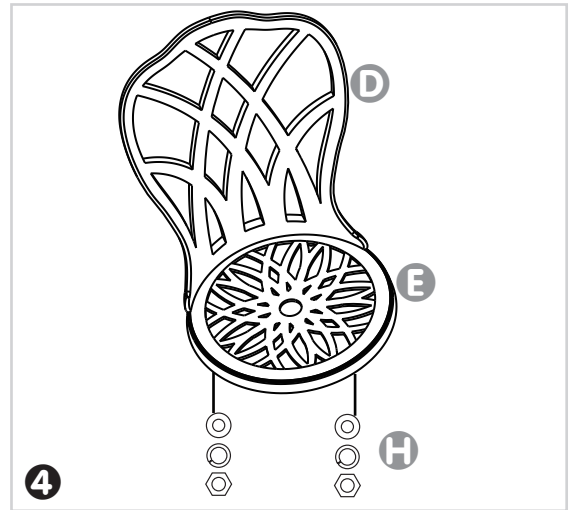

5 Turn the unit upside-down. Attach the **Chair Legs F** to the **Seat E** by placing the holes in the top of each **Leg** over the pre-installed studs on the bottom of the **Seat**. (NOTE: it is easier to begin with the REAR legs and then attach the FRONT legs.) Secure each **Leg** by sliding a **Washer/Spring Washer** onto each stud, then tightening on a **Nut H**.

Repeat to complete second chair.

Hardware: **Washer/Spring Washer/Nut/Cap (8mm) x 16**

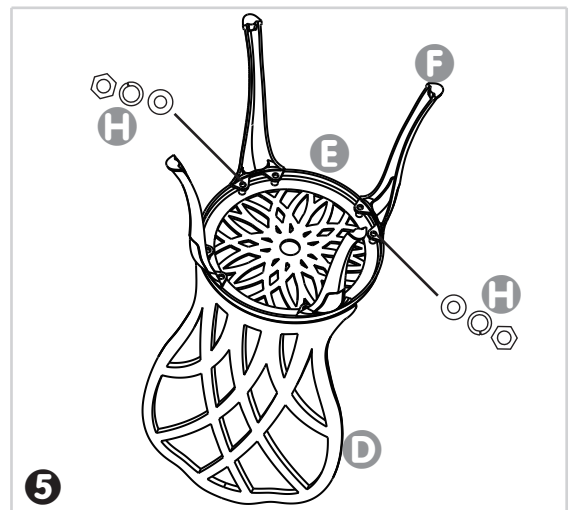

6 Tighten **ALL** nuts on table and chairs using **Wrench K**. Finally, cover all Nuts with **Plastic Caps L/H**.

Your Bistro Set is ready for use!





5 YEAR LIMITED WARRANTY

Customers in the Continental US

All components are warranted for a period of 5 year after date of purchase by the original owner against defects in materials and workmanship under normal use. This warranty does NOT cover normal wear and weathering, assembly and/or maintenance OR use in a commercial application if model is not designated as a commercial model. At Well Traveled Living's sole discretion, products under warranty will be repaired and/or replaced at no charge to the customer. Any returns sent back to Well Traveled Living must be sent via prepaid freight and in the original retail packaging.

For warranty service contact Well Traveled Living at the address, phone numbers or internet site and email listed in this owner's manual. Be sure to have your sales receipt, date of purchase and catalogue/model numbers available when calling. All warranty service will be coordinated by the Well Traveled Living's, Amelia Island, Florida service center.

This warranty is extended only to the original purchaser. Proof of purchase will be required before warranty service is rendered. The sales receipt is the only valid proof of purchase. This warranty only covers failures due to defects in materials or workmanship which occur during normal use. Failures and/or damage which result from accident, negligence, misuse, abuse, neglect, mishandling, alteration or modification, failure to maintain, improper assembly or maintenance, service by unauthorized agency or use of unauthorized components or damage that is attributable to acts of God are NOT covered.

This limited warranty gives you specific legal rights and you may also have other rights which vary from jurisdiction to jurisdiction. The provisions of the United Nations Convention on Contracts for the Sales of Goods shall not apply to this limited warranty or the sale of products covered by this limited warranty.

- THERE ARE NO EXPRESS WARRANTIES EXCEPT AS LISTED ABOVE
- PURCHASER ASSUMES ALL RISKS IN THE ASSEMBLY AND OPERATION OF THIS UNIT
- FAILURE TO FOLLOW WARNINGS AND OPERATIONAL INSTRUCTIONS CONTAINED IN THIS MANUAL CAN RESULT IN SEVERE PROPERTY DAMAGE AND/OR PERSONAL INJURY
- IN NO EVENT WILL WELL TRAVELED LIVING, OR ITS DIRECTORS, OFFICERS OR AGENTS BE LIABLE TO THE PURCHASER OR ANY THIRD PARTY, WHETHER IN CONTRACT, IN TORT, OR ON ANY OTHER BASIS, FOR ANY INDIRECT, SPECIAL, PUNITIVE, EXEMPLARY, CONSEQUENTIAL, OR INCIDENTAL LOSS, COST, OR DAMAGE ARISING OUT OF OR IN CONNECTION WITH THE SALE, MAINTENANCE, USE, OR INABILITY TO USE THE PRODUCT, EVEN IF WELL TRAVELED LIVING OR ITS DIRECTORS, OFFICERS OR AGENTS HAVE BEEN ADVISED OF THE POSSIBILITY OF SUCH LOSSES, COSTS OR DAMAGES, OR IF SUCH LOSSES, COSTS, OR DAMAGES ARE FORESEEABLE. IN NO EVENT WILL WELL TRAVELED LIVING, OR ITS OFFICERS, DIRECTORS, OR AGENTS BE LIABLE FOR ANY DIRECT LOSSES, COSTS OR DAMAGES THAT EXCEED THE PURCHASE PRICE OF THE PRODUCT.
- SOME JURISDICTIONS DO NOT ALLOW THE EXCLUSION OR LIMITATION OF INCIDENTAL OR CONSEQUENTIAL DAMAGES, SO THE ABOVE LIMITATION OR EXCLUSION MAY NOT APPLY TO THE PURCHASER.



Important Notice

Do NOT return to place of purchase—for customer service and warranty issues contact our Customer Service Center at: (866) 985-7877, email us at cservice@welltraveled.net, or go online and live chat at www.wtliving.com. Our hours are: 9 a.m. – 6 p.m., EST, Monday – Friday



Distributed By:
Well Traveled Living
716 S 8th Street, Amelia Island, FL 32034
wtliving.com | cservice@welltraveled.net
(866) 985-7877