

ITEM # RCWST

ROLLING CREEPER WORK SEAT

Assembly Instructions



READ ALL INSTRUCTIONS AND WARNINGS BEFORE USING THIS PRODUCT.

This manual provides important information on proper operation & maintenance. Every effort has been made to ensure the accuracy of this manual. These instructions are not meant to cover every possible condition and situation that may occur. We reserve the right to change this product at any time without prior notice.

IF THERE IS ANY QUESTION ABOUT A CONDITION BEING SAFE OR UNSAFE, DO NOT OPERATE THIS PRODUCT!

HAVE QUESTIONS OR PROBLEMS? DO NOT RETURN THIS PRODUCT TO THE RETAILER

If you experience a problem or need parts for this product, visit our website for more information <http://www.buffalotools.com> or call our customer help line at **1-636-532-9888, Monday-Friday, 8 AM - 4 PM Central Time**. A copy of the sales receipt is required.

FOR CONSUMER USE ONLY – NOT FOR PROFESSIONAL USE.

KEEP THIS MANUAL, SALES RECEIPT & APPLICABLE WARRANTY FOR FUTURE REFERENCE.

SPECIFICATIONS

Weight Capacity: 265 lbs

ASSEMBLY INSTRUCTIONS

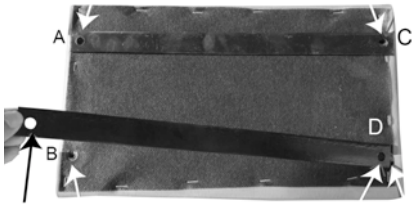

STEP 1 -

Align two #11 Seat Supports with openings.



STEP 2 -

Attach #2 Frame with #3 Screws & #12 Small Washers to seat.



STEP 3 -

Insert #7 Plastic Tray into #8 Base.

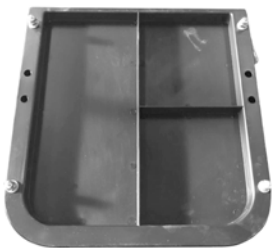

STEP 4 -

Attach Plastic Tray with #10 Casters and #5 Nut and #6 Split Washer.



STEP 5 -

Finish by attaching #2 Frame with #9 Screw, #4 Nut & #13 Washer.

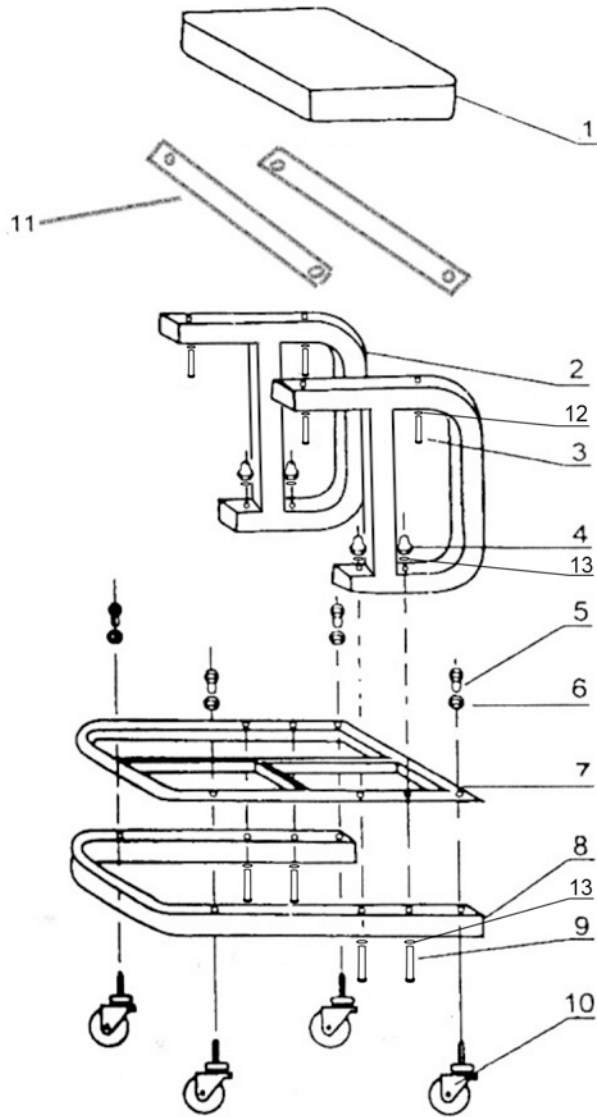

ITEM NO.	DESCRIPTION	QTY
1.	SEAT	1 PC
2.	STEEL FRAME	2 PC
3.	SCREW FOR SEAT	4 PC
4.	NUT	4 PC
5.	NUT	4 PC
6.	SPLIT WASHER	4 PC
7.	PLASTIC TRAY	1 PC
8.	STEEL BASE	1 PC
9.	SCREW	4 PC
10.	CASTER WHEEL	4 PC
11.	SEAT SUPPORT	2 PC
12.	SMALL WASHER	4 PC
13.	WASHER	8 PC