

**JOHN DEERE**  
**WORLDWIDE COMMERCIAL & CONSUMER**  
**EQUIPMENT DIVISION**

---

**Broadcast Spreader**  
**LPBS36JD**

**OMM158881 H8**

**OPERATOR'S MANUAL**



**JOHN DEERE**

All information, illustrations and specifications in this manual are based on the latest information at the time of publication. The right is reserved to make changes at any time without notice.

**COPYRIGHT© 2008**

**Deere & Co.**

**John Deere Worldwide Commercial and Consumer Equipment Division**

**All rights reserved**

**Previous Editions**

**COPYRIGHT©**

**North American Version**

**Litho in U.S.A.**

---

---

# INTRODUCTION

---

---

## Introduction

### Using Your Operator's Manual

Read this entire operator's manual, especially the safety information, before operating.

This manual is an important part of your machine. Keep all manuals in a convenient location so they can be accessed easily.

Use the safety and operating information in the attachment operator's manual, along with the machine operator's manual, to operate and service the attachment safely and correctly.

If your attachment manual has a section called Preparing the Machine, it means that you will have to do something to your tractor or vehicle before you can install the attachment. The Assembly and Installation sections of this manual provide information to assemble and install the attachment to your tractor or vehicle. Use the Service section to make any needed adjustments and routine service to your attachment.

If you have any questions or concerns with the assembly, installation, or operation of this attachment, see your local John Deere dealer or call John Deere Special Services at 1-866-218-8622 for assistance.

Warranty information on this John Deere attachment can be found in the warranty that came with your John Deere tractor or vehicle.

---

---

## Product Identification

### Product Compatibility

This spreader is designed for use with Lawn Tractors and Lawn and Garden Tractors.

---

---

## Safety

### Read Safety in Machine Operator's Manual

Read the general safety operating precautions in your machine operator's manual for additional safety information.

### Operate Safely

- This attachment is intended for use in lawn care and home applications. Do not tow behind a vehicle on a highway or in any high speed application. Do not tow at speeds higher than maximum recommended towing speed.
- Towing speed should always be slow enough to maintain control. Travel slowly over rough ground.
- Do not let children or an untrained person operate machine.
- Do not let anyone, especially children, ride on machine or attachment. Riders are subject to injury such as being struck by foreign objects and being thrown off. Riders may also obstruct the operator's view, resulting in the machine being operated in an unsafe manner.
- Check machine brake action before you operate. Adjust or service brakes as necessary.
- Keep all nuts and bolts tight to be sure the equipment is in safe working condition.
- Keep all parts in good condition and properly installed. Fix damage immediately. Replace worn or broken parts. Replace all worn or damaged safety and instruction decals.
- Do not modify machine or safety devices. Unauthorized modifications to the machine or attachment may impair its function and safety.
- Securely anchor all loads to prevent loads from falling.

- Distribute load evenly for safe travel and unloading of cart.
- Do not obstruct the operator's view during use.

### Towing Loads Safely

- Stopping distance increases with speed and weight of towed load. Travel slowly and allow extra time and distance to stop.
- Total towed weight must not exceed limits specified in towing vehicle operator's manual.
- Excessive towed load can cause loss of traction and loss of control on slopes. Reduce towed weight when operating on slopes.
- Never allow children or others in or on towed equipment.
- Use only approved hitches. Tow only with a machine that has a hitch designed for towing. Do not attach towed equipment except at the approved hitch point.
- Follow the manufacturer's recommendations for weight limits for towed equipment and towing on slopes. Use counterweights or wheel weights as described in the machine operator's manual.
- Do not turn sharply. Use additional caution when turning or operating under adverse surface conditions. Use care when reversing.
- Do not shift to neutral and coast downhill.

### Protect Bystanders

- Keep bystanders away when you operate a towed attachment.
- Before you back machine and attachment, look carefully behind attachment for bystanders.

### Keep Riders Off Towed Attachment

Keep riders off of a towed attachment.

Riders on a towed attachment are subject to injury, such as being struck by objects and being thrown off the attachment during sudden starts, stops and turns.

Riders obstruct the operator's view, resulting in the attachment being used in an unsafe manner.

Keep riders off of hitch bracket.

### Avoid Injury From Drawbar

Before you disconnect an attachment from machine hitch plate:

- Unload attachment.
- Stop attachment on level ground.
- Stop machine engine.
- Lock machine park brake.
- Block attachment wheels.
- Make sure hands, feet or other body parts are not under drawbar.

# ASSEMBLY

## Assembly

### Parts in Kit

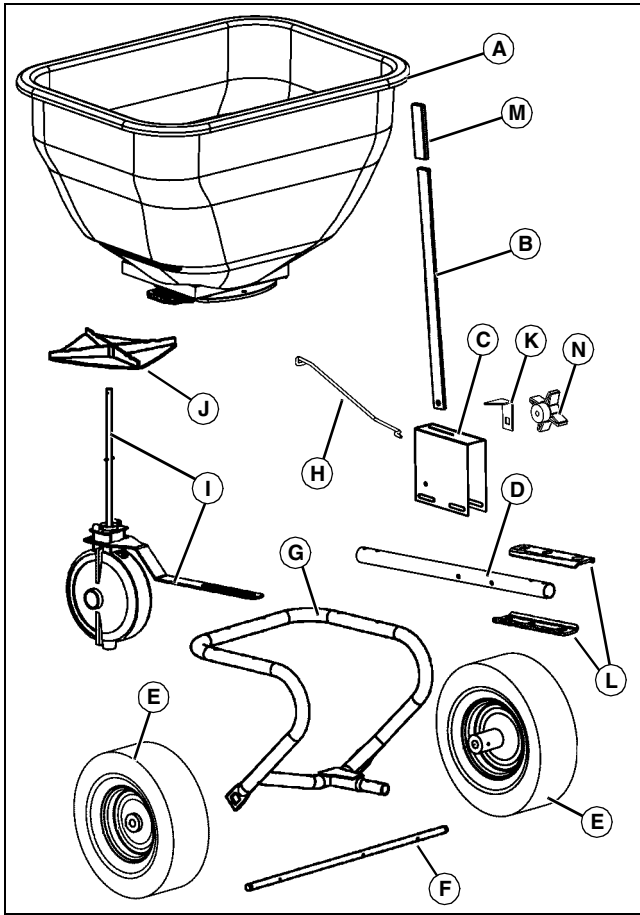

MX40574

Qty.	Description
1	Hopper Assembly (A)
1	Handle, Flow Control (B)
1	Gage Plate (C)
1	Tube, Tow (D)
2	Wheel (E)
1	Axle (F)
1	Support Frame, Hopper (G)
1	Link Rod (H)
1	Transmission and Bracket (I)

### Hardware Bag (Z-1911)

Qty.	Description
1	Fan (J)
1	Handle Stop (K)

Qty.	Description
2	Clevis, Hitch (L)

### Hardware Skin Pack (Z-1912)

Qty.	Description
1	Grip, Flat (M)
1	Knob, 4-Prong (N)
5	Nylon Locknut, 5/16 in.
2	Nut, Hex, 5/16 in.
6	Nylon Locknut, 1/4 in.
6	Nylon Washer, Flat, 1/4 in.
6	Bolt, Hex, 1/4 x 1-3/4 in.
2	Bolt, Hex, 5/16 x 2-1/4 in.
1	Fan Driver
1	Hairpin Cotter
8	Washer, Flat, 5/16 in.
2	Snap Ring, E-Type
2	Bearing, Axle
6	Washer, Flat, 5/8 in.
1	Hairpin Cotter, Special
1	Agitator Spring
1	O-Ring, 3/8 in.
1	Cotter Pin, 1/8 x 1 in.
2	Carriage Bolt, 5/16 x 2 in.
1	Hitch Pin, 1/2 x 2-1/2 in.
1	Hairpin Cotter, 1/8 in.
1	Spacer, Latch
2	Washer, Special
1	Washer, Curved Spring
3	Bolt, Hex, 5/16 x 2-3/4 in.
1	Spring, Latch
1	Carriage Bolt, 5/16 x 3/4 in.
2	Locknut, Hex, 5/16 in.
4	Bushing, Pivot Plate

### Assemble Hopper to Frame

1. Remove hopper assembly, support frame, and inner carton from box.
2. Remove protective foam from bottom of hopper.

# ASSEMBLY

**NOTE:** Hardware for the next step is found on the Hardware Skin Pack (Z-1912), Panel A.

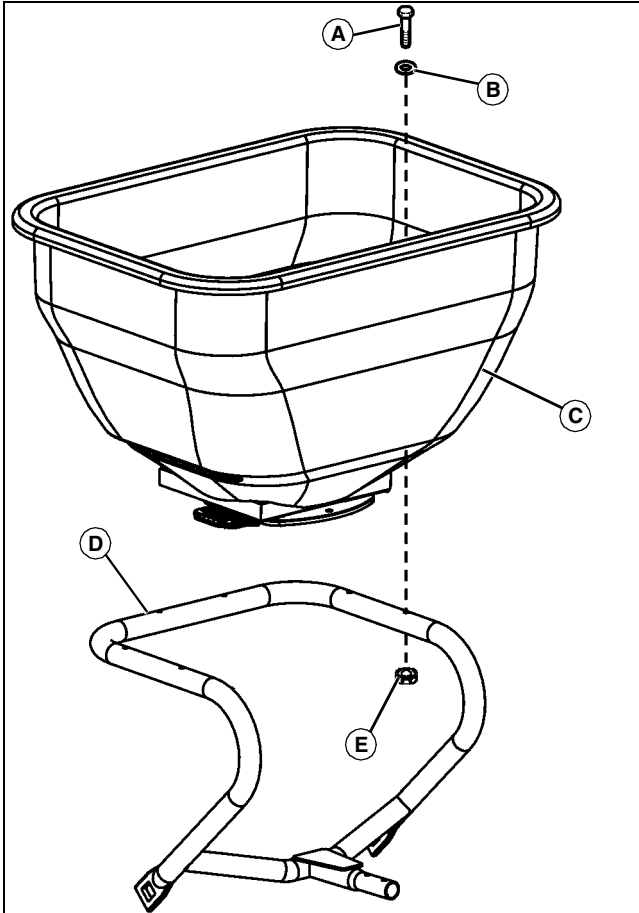

MX40299

3. Install six 1/4 x 1-3/4 in. hex bolts (A), and 1/4 in. flat nylon washer (B) through top of hopper (C) and through support frame (D), as shown. Secure bottom of bolt with 1/4 in. nylon locknut (E). To avoid damage to plastic, do not overtighten hardware.

**NOTE:** Hardware for the next step is found on the Skin Pack (Z-1912), Panel B.

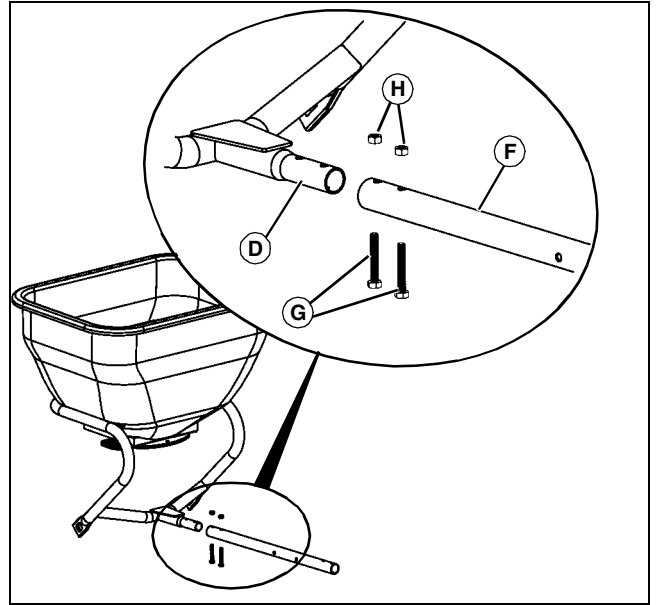

MX40300

4. Install tow tube (F) onto support frame (D) with two 5/16 x 2-1/4 in. hex bolts (G) and 5/16 in. hex nuts (H). Tighten nuts to 30 N•m (22 lb-ft), or two complete turns after finger tight.

## Install Transmission and Wheels

**NOTE:** Hardware for the next step is found on the Hardware Skin Pack (Z-1912), Panel C.

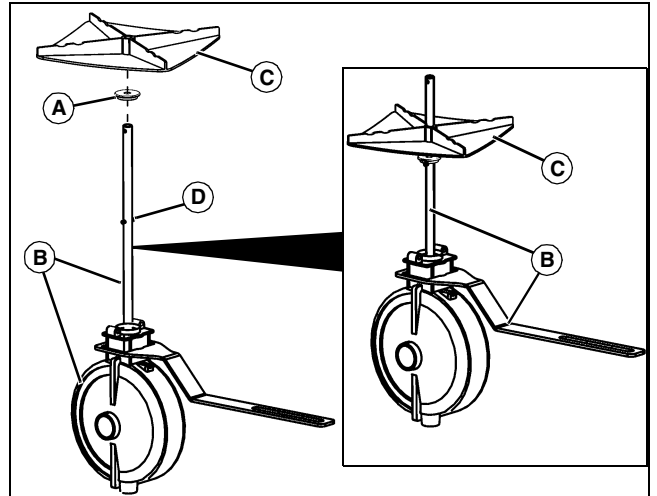

MX40403

1. Slide the fan driver (A) on the transmission assembly (B) shaft (with the larger surface facing upward) and fan (C) onto the transmission assembly (B) until both rest on the spring pin (D), as shown.

# ASSEMBLY

**NOTE:** Hardware for the next step is found on the Hardware Skin Pack (Z-1912) Panel D.

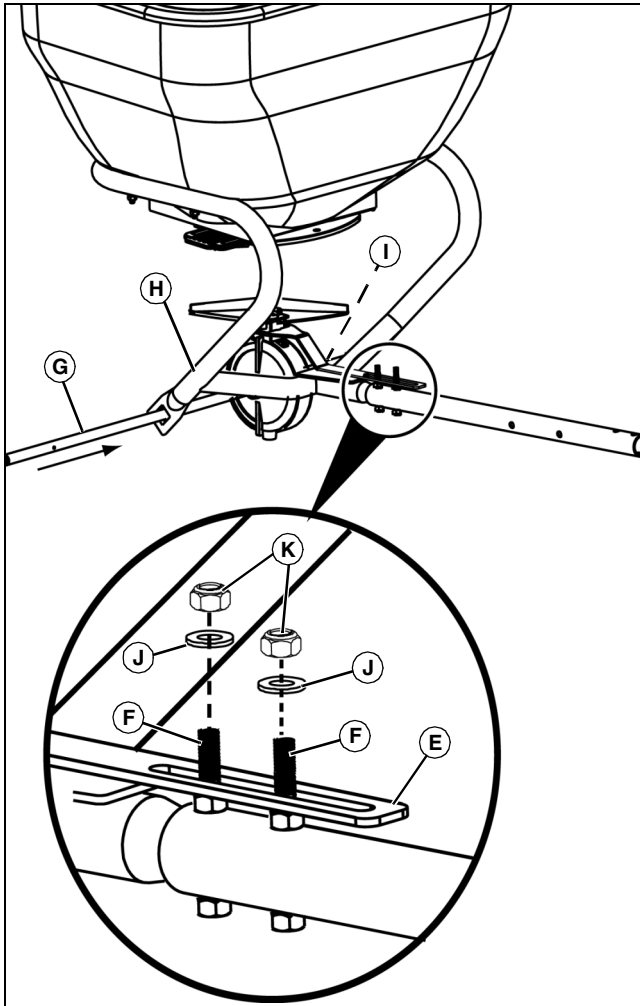

MX40301

2. Raise transmission into position by installing transmission fan shaft into center hole of the control plates on the bottom of the hopper. Lower transmission bracket (E) onto bolts (F).

3. Install axle (G) through support frame assembly (H) with offset hole near center of axle to line up with hole in spreader transmission (I).

**IMPORTANT: Avoid damage! To avoid transmission damage, do not adjust slot in transmission bracket forward or rearward. The slot will self center as hardware is tightened.**

4. Secure the transmission bracket by installing two 5/16 in. flat washers (J) and two 5/16 in. nylon locknuts (K). Tighten hardware finger tight.

**IMPORTANT: Avoid damage! The hole in the transmission hub and axle must be closely aligned to prevent hairpin cotter from binding upon insertion.**

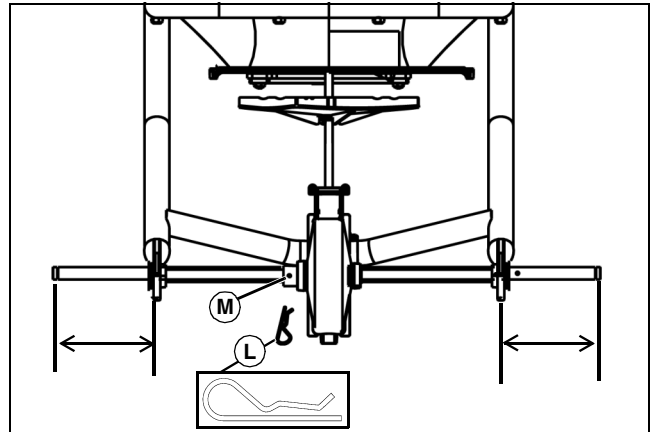

MX40302, MX21908

**Picture Note:** View from rear of spreader.

5. Slide axle until it is centered through transmission as shown in diagram. Install hairpin cotter (L) through transmission and axle center hole (M). This may be a force fit.

**NOTE:** Hardware for the next step is found on the Hardware Skin Pack (Z-1912), Panel E.

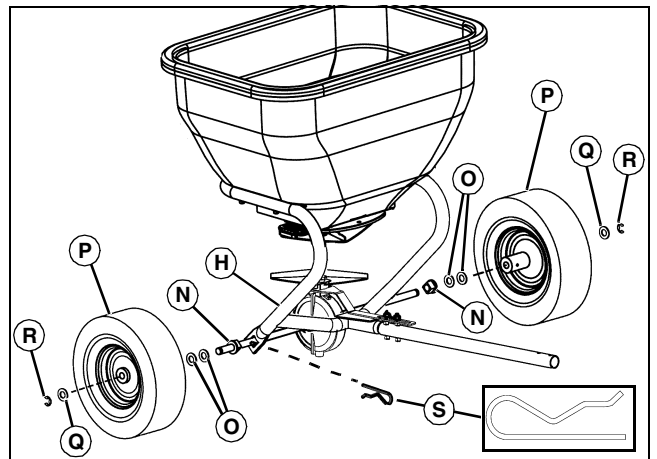

MX40303, MX21907

6. Install axle bearing (N) onto each side of axle so square end of bearing fits into square hole of support frame assembly (H).

7. Install two 5/8 in. flat washers (O) onto each side of axle. Lubricate the axle ends with general purpose grease.

8. Install wheel (P), 5/8 in. flat washer (Q), and E-type snap ring (R) onto each end of axle, as shown in diagram.

**NOTE: Delete washers (O), if required, to allow hairpin cotter, special to slip into hole.**

9. Install hairpin cotter, special (S) through inside hole in wheel hub and axle.

10. Tighten hardware installed in Step 4.

# ASSEMBLY

## Install Agitator Spring and Clevis

**NOTE: Hardware for the next step is found on the Hardware Skin Pack (Z-1912), Panel F.**

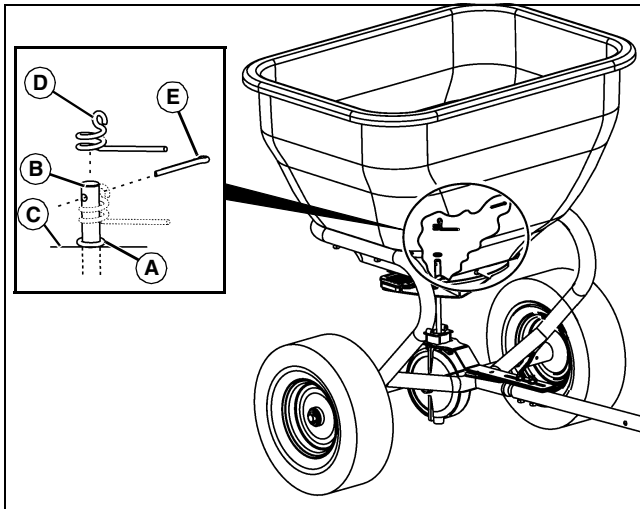

MX40576

1. Install 3/8 in. O-ring (A) on transmission shaft (B) until seated on bottom of hopper (C).
2. Install agitator spring (D), and secure with 1/8 x 1 in. coter pin (E) through top loop in agitator spring and hole in transmission shaft, as shown. Bend legs of coter pin to secure its placement.

**NOTE: Parts and hardware for the next step are found in the Hardware Bag (Z-1911) and on the Hardware Skin Pack (Z-1912), Panel G.**

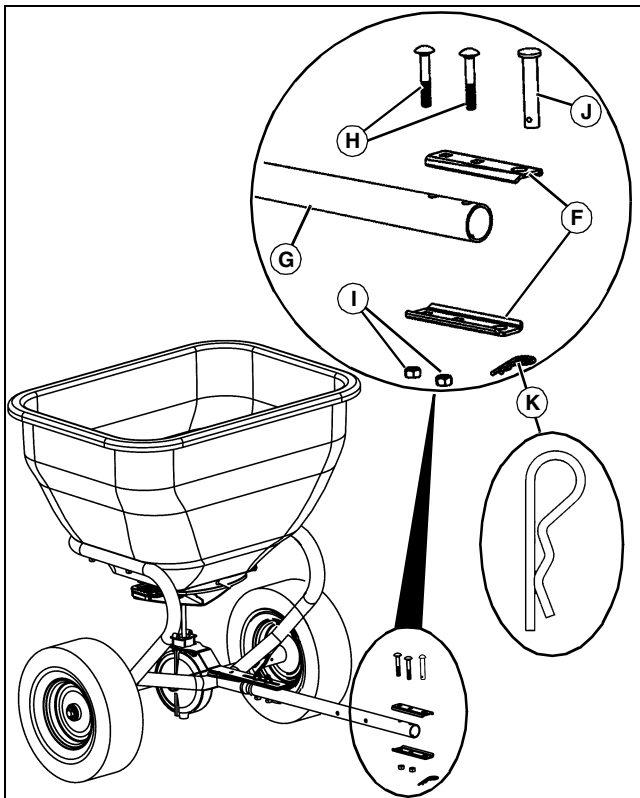

MX40306

3. Install hitch clevis brackets (F) onto tow tube end (G) with two 5/16 x 2 in. carriage bolts (H) and 5/16 in. nylon locknuts (I), as shown. Tighten

hardware finger tight.

4. Install 1/2 x 2-1/2 in. hitch pin (J) and 1/8 in. hairpin cotter (K) through end of clevis brackets, as shown.
5. Tighten hardware installed in Step 3.

## Assemble Gage Plate

### Install Handle Stop

**NOTE: Parts and hardware for the next steps are found in Hardware Bag (Z-1911) and on Hardware Bag (Z-1912), Panel H.**

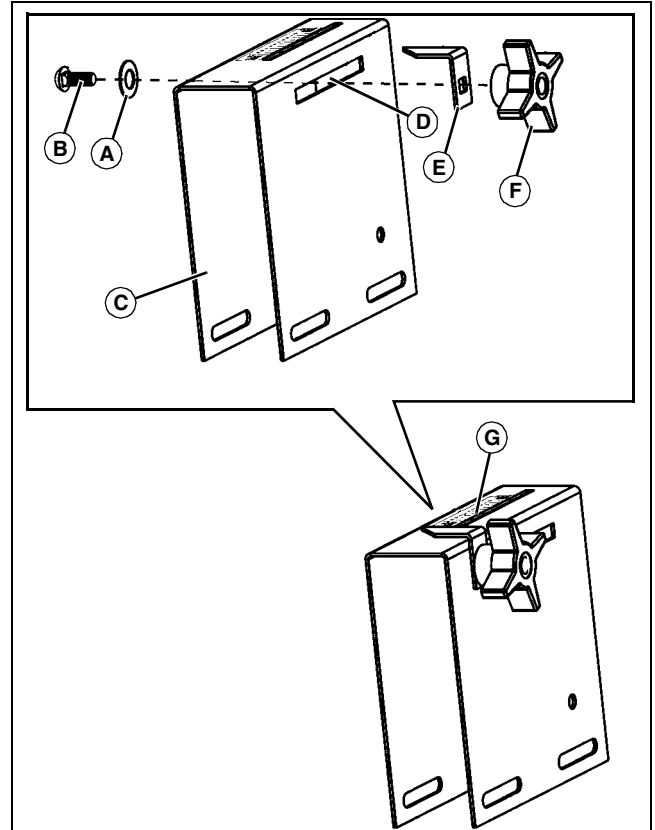

MX40577

1. Install curved spring washer (A) onto 5/16 x 3/4 in. carriage bolt (B). Direction of washer is not important.
2. Insert carriage bolt (B) and washer (A) from the inside of the gage plate (C) through the slot (D) so the end of the bolt protrudes outward.
3. Attach handle stop (E) and 4-prong knob (F) to carriage bolt (B).
4. Move handle stop (E) to the full open position and tighten knob (F) (see label (G) on top of gage plate).

# ASSEMBLY

## Attach Flow Control Handle

**NOTE: Rotate link rod (A) as necessary to match diagram.**

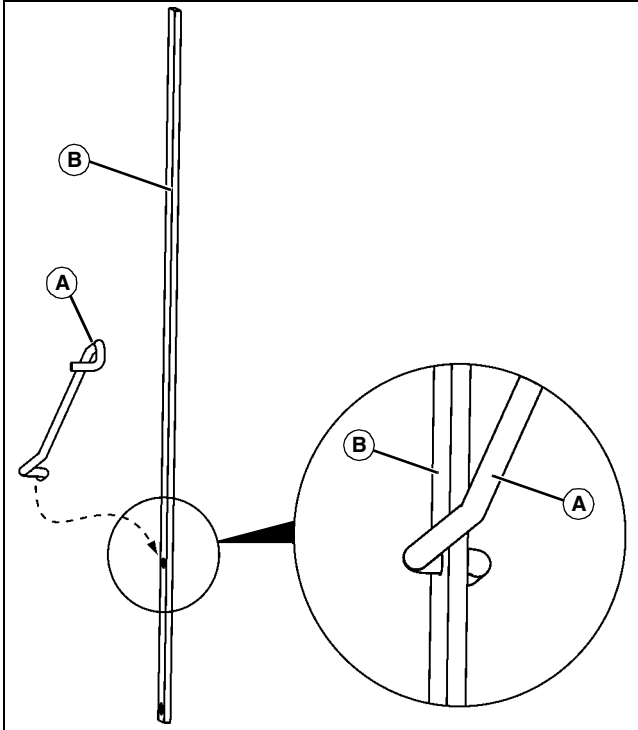

MX40578

1. Insert the 'S' shaped end of the link rod (A) through the upper hole of the flow control handle (B).

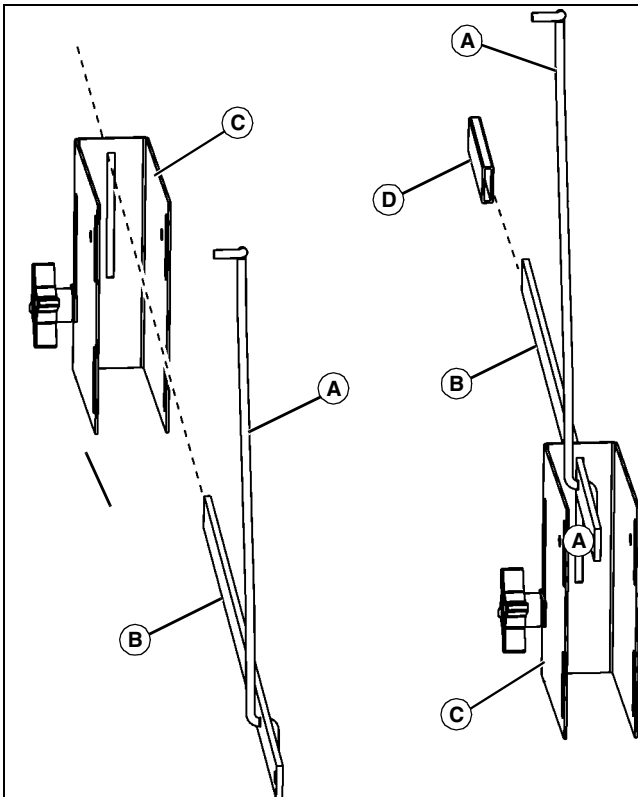

MX40581

2. Position gage plate (C) as shown.

3. Insert the flow control handle (B) through the gage plate (C). Insure that the link rod (A) is in the up position and end of link rod is orientated as shown.

4. Slide the flat grip (D) over the end of the flow control handle (B), as shown.

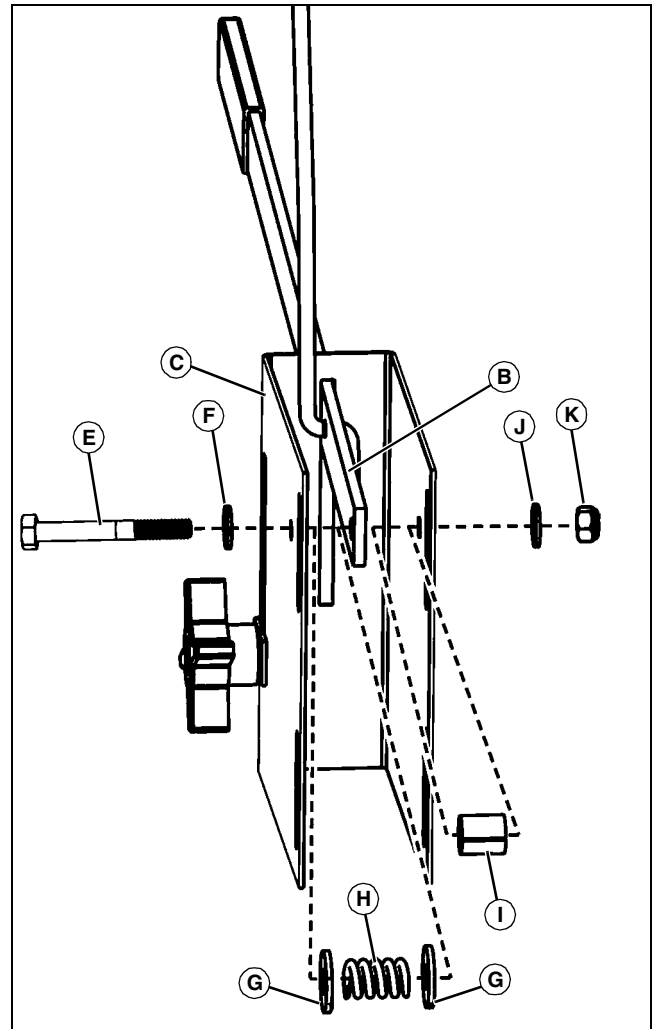

MX40579

5. Insert one 5/16 x 2-3/4 in. hex bolt (E) and one 5/16 in. flat washer (F) through one side of the gage plate, as shown (C).

6. Install one special washer (G), one spring (H), and a second special washer (G).

7. Install hex bolt assembly through flow control handle (B), one latch spacer (I), and out opposite side of gage plate (C).

8. Secure assembly with one 5/16 in. flat washer (J), and one 5/16 in. nylon locknut (K).

# ASSEMBLY

## Attach Gage Plate to Spreader

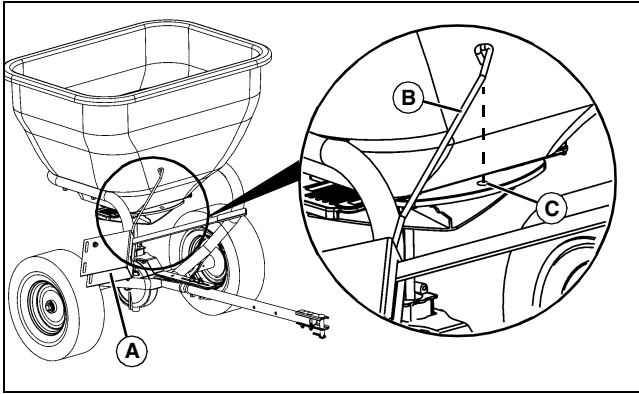

MX40308

1. Hold assembled gage plate (A) over tow tube with flow control handle up and link rod (B) facing hole (C) on the hopper control plate.
2. Rotate assembled gage plate (A) approximately 90° clockwise, and insert formed end of the of the link rod (B) into the hole (C) on the hopper control plate, as shown.

**NOTE: Hardware for the next steps are found on the Hardware Skin Pack (Z-1912), Panel J.**

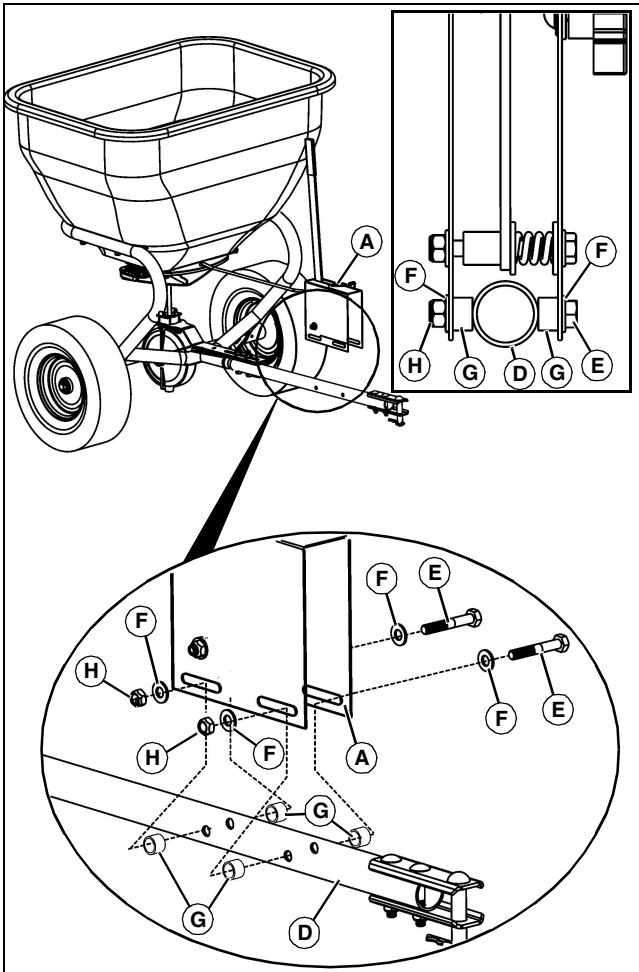

MX40580

3. Rotate assembled gage plate (A) counter-clockwise until the handle is oriented upward and the bottom of the gage plate is over the tow tube (D).
4. Attach the gage plate to the tow tube as shown by inserting two 5/16 x

2-3/4 in. bolts (E) and two 5/16 in. flat washers (F) through one side of the gage plate, as shown(A).

**NOTE: Do not tighten the locknuts until after calibrating the gage plate.**

5. Install four pivot plate bushings (G) (two on each side of tow tube (D)), two more 5/16 in. flat washers (F), and secure on opposite side with two 5/16 in. hex locknuts (H).

## Calibrate Gage Plate

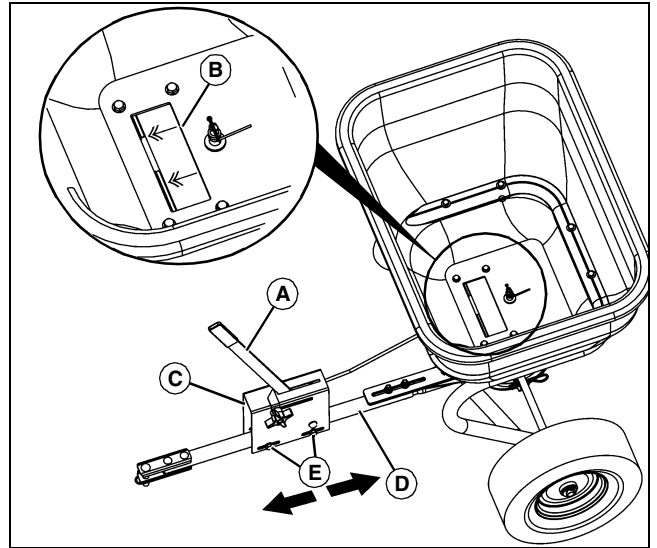

MX40310

1. Move flow control handle (A) to the open position (towards front clevis).
2. Make sure that hopper control plate opens fully (B); if not, slide the gage plate (C) forward or backward until control gate is fully open.
3. Tighten gage plate (C) securely to the tow tube (D) by tightening the two sets of 5/16 in. hardware (E) holding gage plate to tow tube.

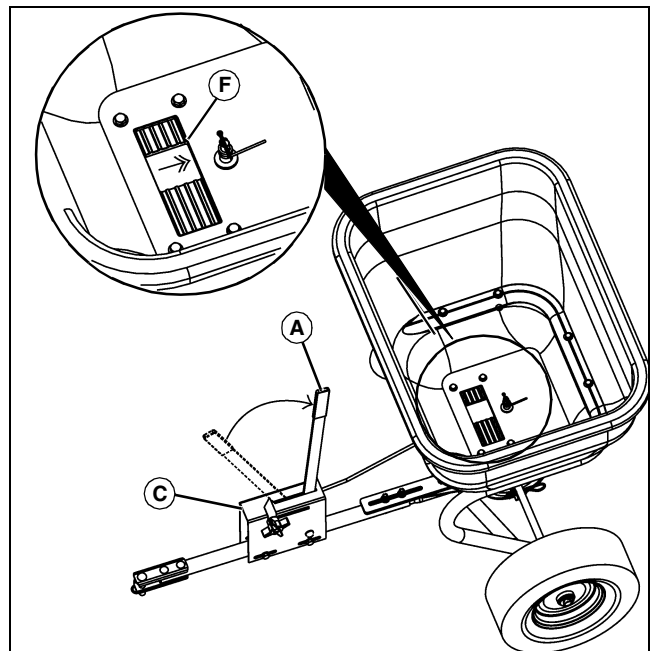

MX40311

4. Move flow control handle (A) to the close position (towards rear of unit). Verify hopper control gate fully closes (F).



# INSTALLING

5. Securely tighten the flow control handle (A) to the gage plate (C), compressing the spring. Flow control handle should have resistance to movement.

## Fan Height Adjustment

**NOTE: The four tabs on the fan should be compressed against the fan driver. If pressure is not applied, the fan connection will be loose resulting in poor performance.**

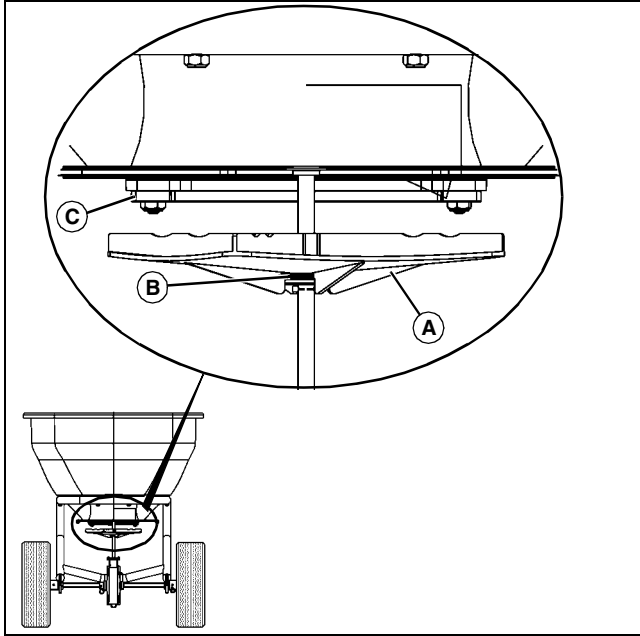

MX40304

1. Adjust fan (A) with fan driver (B) upwards on shaft as close to bottom of hopper (C) without touching during operation. Make sure fan driver engages the four plastic tabs on the bottom of fan.

## Installing

### Installing the Spreader

1. Park machine safely. See "Parking Safely" in Safety section.

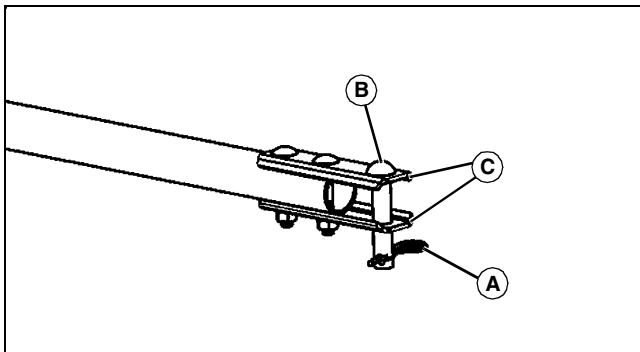

MX34595

2. Remove 1/8 in. hairpin cotter (A) and hitch pin (B) from hitch clevis (C) of spreader.

3. Pull spreader forward and position hitch clevis to straddle machine rear hitch plate or drawbar (not shown). Align all hitch pin holes, then install hitch pin down through hitch clevis and machine hitch, securing with 1/8 in. hairpin cotter.

## Removing

### Removing the Spreader

1. Park machine safely. See "Parking Safely" in the Safety section.
2. Remove all materials from the hopper before removing spreader from machine.



**CAUTION: Avoid injury! Keep hands, feet and other body parts away from under drawbar.**

3. Remove 1/8 in. hairpin cotter from hitch pin.
4. Hold spreader tow tube to remove pressure from hitch pin, then remove hitch pin from hitch clevis and rear hitch plate or drawbar on machine.
5. Pull or push spreader backward to disengage hitch clevis from machine hitch, install hitch pin in hitch clevis for storage and secure with 1/8 in. hairpin cotter.

## Storing

The spreader can be tipped upright and stored against a wall using less space:

1. Remove any loose material from hopper and fan using a brush and garden hose. The spreader should be clean and dry before storing.
2. Roll spreader to desired storage area, lift hitch clevis to pivot spreader to vertical position.

## Operating

### Daily Operating Checklist

- Check for loose or missing hardware.
- Make sure all connections are tight.
- Make sure attachment responds properly to controls.
- Check for debris build-up that could obstruct proper motion of the spreader control components.
- Check to make sure tires are inflated to 20 psi (1.3 bar) (138 kPa) maximum.

### Operating the Spreader

The fan speed and the spread width are controlled by the speed of the vehicle. The recommended operating speed is slightly faster than that of a brisk walk, 3 mph. 3 mph is equal to the vehicle traveling 40 ft in nine seconds.

The flow control assembly operates the flow control plate. The flow control assembly is marked 0 (closest) to 10 (fully open). The position selected determine the amount of material to be broadcast. The higher the number, the heavier the application of material.

Flow control setting for many of the common fertilizers, insecticides, and grass seeds are provided in the alphabetized table listing flow control settings. If the product is not listed in the flow control settings table, use the calibration guide to set the flow control.

The agitator spring located inside the hopper provides consistent material flow of pelletized materials and seed. It is not designed to break up lumps of material or seed. Break up any lumps as you fill the hopper.

After determining the correct setting number for your material, loosen knob and move stop bracket to that position. Tighten knob. Move flow control handle to the lock position to open the flow control plate.

# SERVICE

## Directional Control

### Normal Operation (Uniform Spreading)

Fertilizers, insecticides, and grass seed each have different particle size and weight. This can be referred to as particle density. As the particles are impacted by the fan, the distribution can be centered or slightly off center depending on particle density and forward vehicle speed.

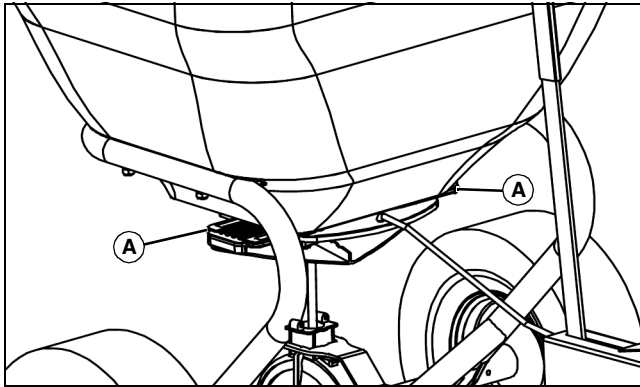

MX25911

Adjustment can be made by moving the direction control plate (A) to the right or left.

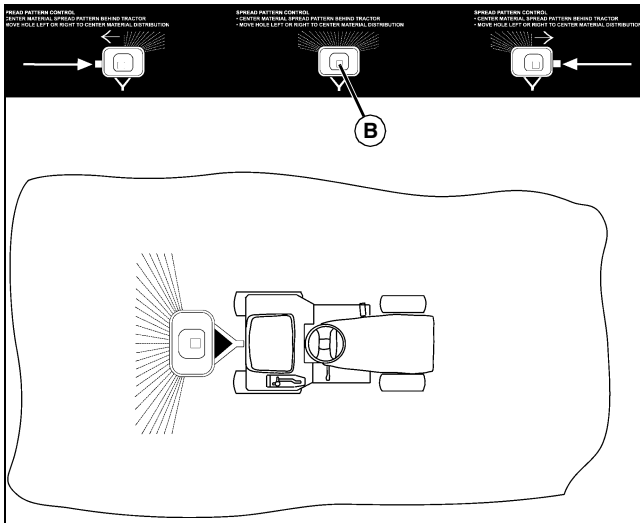

MX40313

The directional decal located below the directional control plate will aid you in adjusting the spread pattern. For most applications the plate should be placed close to the center position (B) described by the label above. If the material is coming out right or left during operation, adjustment of this plate should be made to center the material distribution pattern behind the vehicle. Your broadcast spreader has a patented feature to allow you to adjust for centering.

## One Side Only Spreading

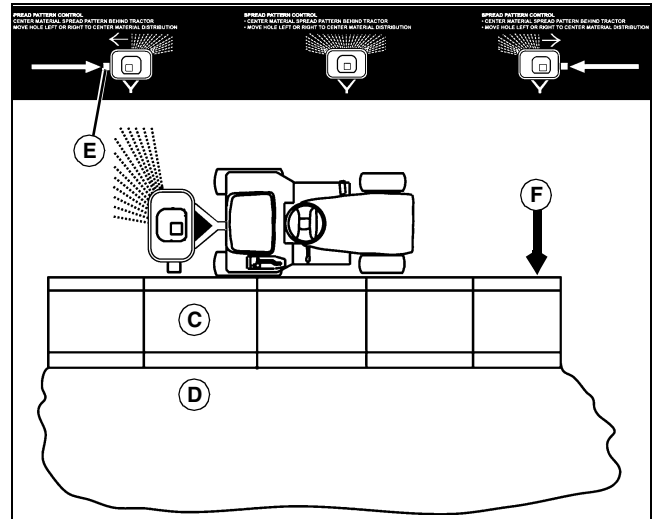

MX40395

The directional control plate can be used for adjusting the material spread pattern when spreading near sidewalks (C), planting beds (D), etc. With the plate adjusted to the left side (E), the directional control plate only operates with 90% shut-off of material to the right side (F) of the vehicle as shown in the illustration above.

## Operating Tips

- Always operate your spreader with the speed limit for which it was designed - 3 mph.
- When backing, carefully back straight to avoid jack knifing, which could result in damage to equipment.
- Only tow your spreader behind vehicles for which it was designed - riders, and lawn and garden tractors.
- Do not load the hopper with more than the maximum weight capacity of 79 kg (175 lb).
- Break up any lumps as you fill the hopper.
- Do not use on windy days, especially when spreading fine grass seed or herbicides.
- Optimum hitch height is 18 - 23 cm (7- 9 in.).
- The flow control handle should have resistance to movement. Increase or decrease spring tension as required to get desired flow control handle resistance.

## Service

### Maintenance Tips

- The key to years of trouble-free service is to keep your spreader clean and dry.
- Never allow material to remain in hopper for extended periods of time.
- Should rust develop, sand lightly and then paint area with enamel.
- Periodically check all fasteners for tightness.
- Rinse/dry inside and outside of spreader after each use. Move flow control as you rinse, to avoid build up of material.

# SERVICE

## Annual Maintenance

### Remove Wheels

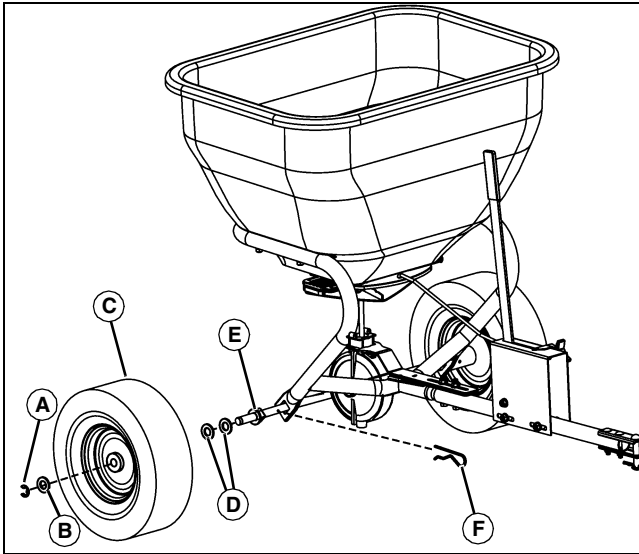

MX40396

1. Remove E-type snap ring (A), 5/8 in. flat washer (B), wheel (C), 5/8 in. flat washer (D) (if installed), and axle bearing (E). Remove hairpin cotter, special (F).

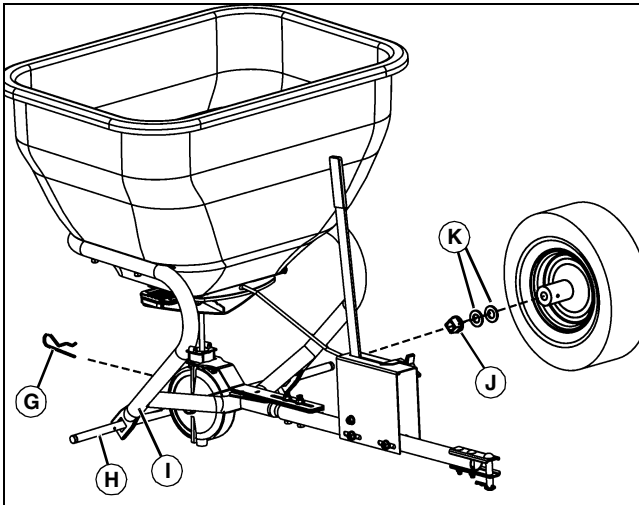

MX40397

2. Remove hairpin cotter (G), and slide axle (H) out from support frame (I). Remove axle bearing (J) and 5/8 in. flat washers (K) (if installed) on axle.
3. Clean parts.
4. Lightly lubricate both axle ends.

### Remove Gage Plate and Remaining Components

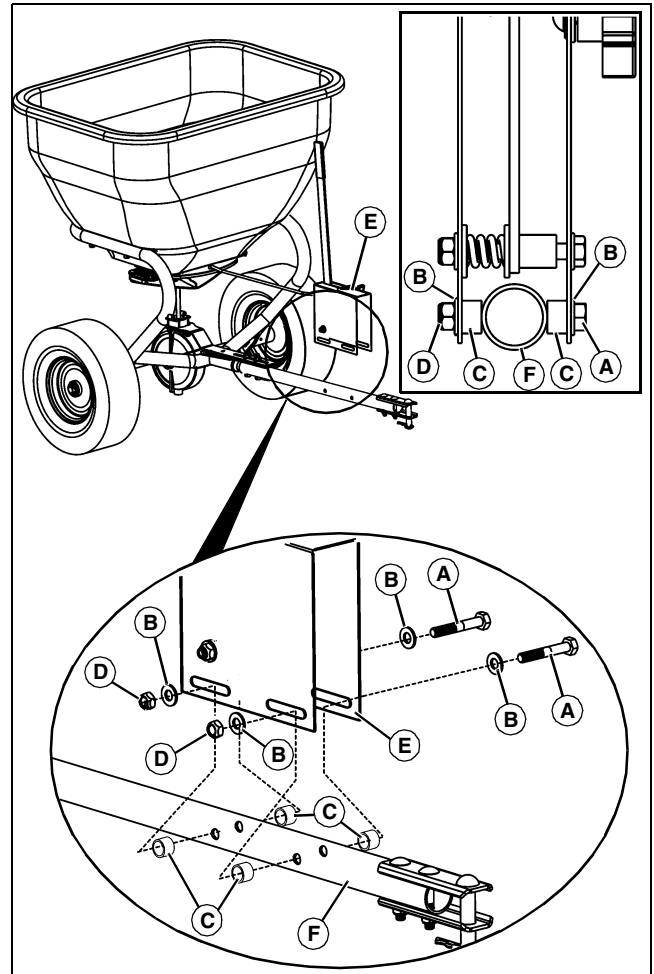

MX40309

1. Remove two 5/16 x 2-3/4 in. hex bolts (A), four 5/16 in. flat washers (B), four pivot plate bushings (C), and two 5/16 in. nylon locknuts (D). Remove assembled gage plate (E) from tow tube (F).

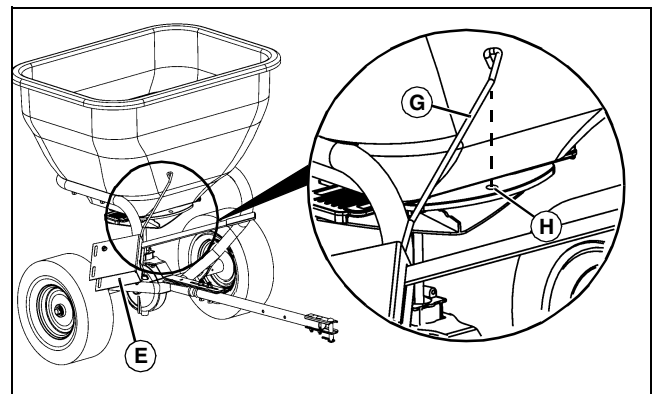

MX40308

2. Rotate assembled gage plate (E) approximately 90° clockwise, and remove formed end of the of the link rod (G) from hole (H) on the hopper control plate, as shown.

# TROUBLESHOOTING

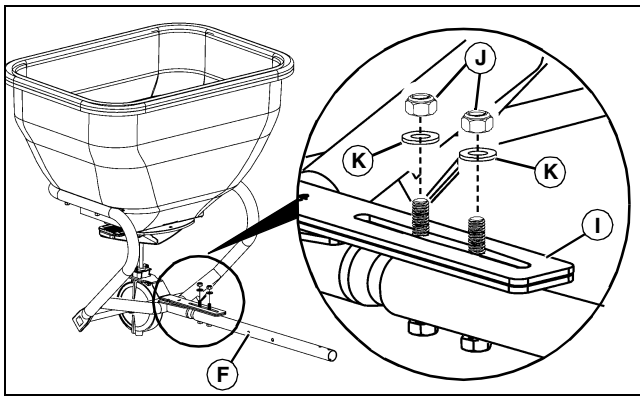

MX40398

3. Remove the transmission bracket (I) from tow tube (F) by removing two 5/16 in. nylon locknuts (J) and two 5/16 in. flat washers (K).

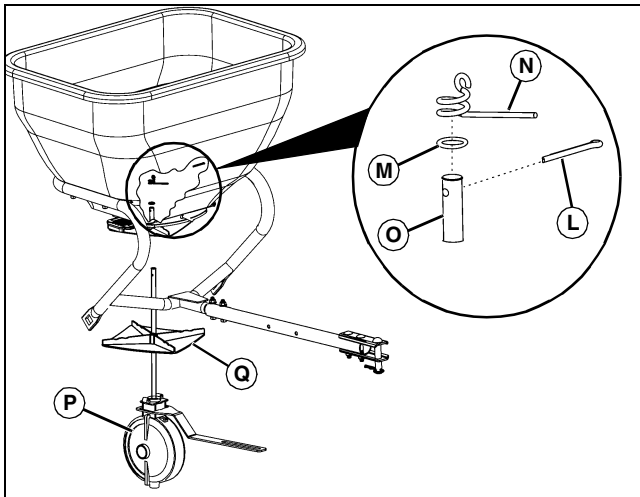

MX40399

4. Remove 1/8 x 1 in. cotter pin (L), 3/8 in. O-ring (M), and agitator spring (N) from transmission shaft (O).

5. Remove transmission (P) assembly.

6. Clean fan (Q).

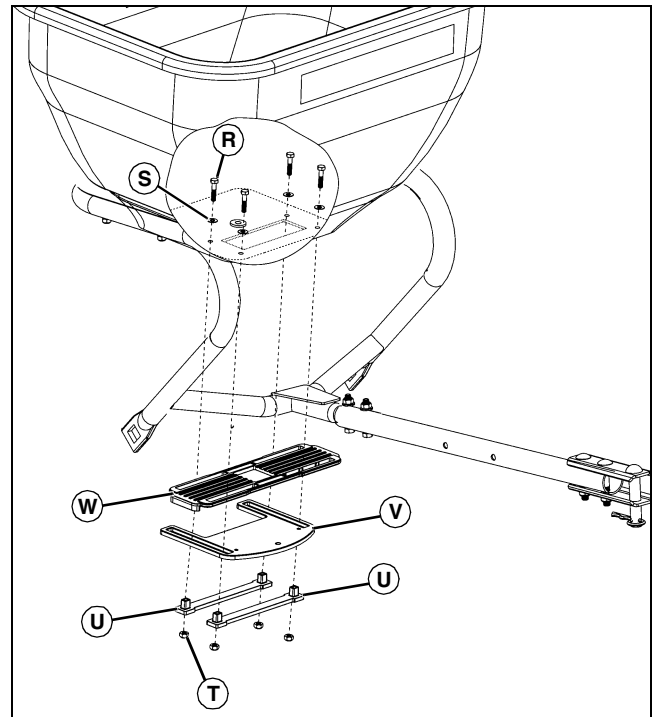

MX40400

7. Remove the four bolts (R), washers (S), nuts (T) and straps (U) that hold the gate (V) and directional control plate (W).

8. Separate parts as shown.

9. Clean thoroughly using soap and water.

**NOTE: Be sure to calibrate the gage plate before using spreader (see "Calibrate Gage Plate" in the Assembly section).**

10. Assemble parts reverse order of removal.

## Troubleshooting

### Using Troubleshooting Chart

If you are experiencing a problem that is not listed in this chart, see your authorized dealer for service.

When you have checked all the possible causes listed and you are still experiencing the problem, see your authorized dealer.

### Troubleshooting Chart

IF	CHECK
Not enough or too much fertilizer dispensed.	Calibrate the gage plate.
Flow control handle hard or will not operate.	Flow control handle hardware too tight: Loosen 5/16 x 2-3/4 in. bolt on flow control handle assembly. Take gate and directional control plates apart; clean plates out with soap and water.

# SPECIFICATIONS

IF	CHECK
Fan does not turn when pulling.	<p>Find or replace missing hairpin cotter, special on right wheel rim.</p> <p>Find or replace missing hairpin cotter in transmission.</p> <p>Check position of fan and fan driver.</p> <p>Check for transmission malfunction: With the broadcast spreader attached to your machine, lift the drive wheel and rotate. At the same time apply gentle pressure to the fan shaft. It should turn with each rotation of the wheel.</p>

## Specifications

### LPBS36JD Broadcast Spreader

#### Dimensions

Size (maximum weight)..... 79 kg (175 lb)

Capacity ..... 0.10 cu m (3.5 cu ft)

Wheels and Tires ..... 33.0 x 10.2 cm (13 x 5 in) Turf tread

Tire Inflation..... 138 kPa (20 PSI)

(Specifications and design subject to change without notice.)

### Flow Control Settings for Specific Products



**CAUTION: Avoid injury! Chemicals can be dangerous. Avoid injury to operator or bystanders:**

- Read chemical container label for handling instructions. A Material Safety Data Sheet (MSDS) should be supplied by the chemical dealer and provides proper safety information.
- Wear proper clothing and safety equipment while handling or applying chemicals.
- Prohibit all smoking, drinking, and eating around chemicals.

The following is a list of flow control settings for specific products available for use with the spreader. Some products may not be available in all areas. Flow control settings are based on 3 mph forward speed.

lbs/1000 square feet	Flow Control Setting at 3 mph <sup>a</sup>	Materials <sup>b</sup>
10	3	All American All Purpose Fertilizer 10-10-10
3.8	2.5	Bayer Season Long Grub Control
2.9	2	Bayer Season Long Grub Control
3	2	Bayer Complete Insect Killer
2	1.5	Bayer Complete Insect Killer
3	1.5	Bayer Power Force Multi-Insect Killer
2	1	Bayer Power Force Multi-Insect Killer
3	1.5	Bayer Grub Control

lbs/1000 square feet	Flow Control Setting at 3 mph <sup>a</sup>	Materials <sup>b</sup>
2	1.5	Bayer Grub Control
3.2	2	Bayer Lawn Fertilizer Plus Weed Control II 30-3-4
3.8	2	Bayer Season Long Grub Control
2.9	1.5	Bayer Season Long Grub Control
3.6	2	Bayer Lawn Starter Fertilizer 20-27-5
3.2	2	Bayer Lawn Fertilizer Plus Crabgrass Preventer 30-3-4
3	2	Eliminator Ant, Flea, and Tick Killer Granules
2.5	1.5	Eliminator Ant, Flea, and Tick Killer Granules
2	1.5	Eliminator Ant, Flea, and Tick Killer Granules
2	2	Eliminator 5% Diazinon Killer Granules
7	2.5	Howard Johnsons All-Purpose Fertilizer 8-8-8
7	2.5	Howard Johnsons All-Purpose Fertilizer 10-10-10
7	2.5	Howard Johnsons All-Purpose Fertilizer 12-12-12
5	2	Ironite 1-0-0
4	2	Klay Soft Pelletized Gypsum Soil Conditioner
3	1.5	Klay Soft Pelletized Gypsum Soil Conditioner
2	1.5	Klay Soft Pelletized Gypsum Soil Conditioner
4	2	Lesco Pre-M 0.86% Plus Fertilizer 25-0-7
4.2	2	Lesco Starter Fertilizer 18-24-12
4.2	2	Lesco Turf Fertilizer 24-2-11
4	2	Lesco Weed and Feed
8	3.5	Master Turf Ultimate Tall Fescue Blend
4	2.5	Master Turf Ultimate Tall Fescue Blend
8	3.5	Milorganite 6-2-0
16	5	Milorganite 6-2-0
3.2	2	Miracle-Gro Lawn Fertilizer Plus Weed Control 28-3-3
3.6	2	Miracle-Gro STarter Lawn Fertilizer 20-27-5
3.1	1.5	Miracle-Gro STarter Lawn Fertilizer 29-3-4
9.6	3	Ortho Lawn Insect Killer Granules
4.8	2	Ortho Lawn Insect Killer Granules
2.4	1	Ortho Lawn Insect Killer Granules
1.2	1	Ortho Lawn Insect Killer Granules
4	2	Ortho Max Insect Killer for Lawns

# SPECIFICATIONS

lbs/1000 square feet	Flow Control Setting at 3 mph <sup>a</sup>	Materials <sup>b</sup>
2	1.5	Ortho Max Insect Killer for Lawns
1	1	Ortho Max Insect Killer for Lawns
10	3	Parkers Super Soilife Lawn and Garden Fertilizer 10-10-10
6.5	2	Parkers Super Soilife Lawn and Garden Fertilizer 16-4-8
3.6	2	Pennington Lawn Starter Fertilizer 18-24-6
10	4	Pennington Master Turf High Traffic Lawn Seed Mixture
5	3	Pennington Master Turf High Traffic Lawn Seed Mixture
8	4	Pennington Master Turf Shady Lawn Seed Mixture
4	3	Pennington Master Turf Shady Lawn Seed Mixture
10	4	Pennington Master Turf Sun and Shade Lawn Seed Mixture
5	3	Pennington Master Turf Sun and Shade Lawn Seed Mixture
2	1.5	Real-Kill Multi-Purpose Lawn and Garden Insect Killer
2.5	1.5	Real-Kill Multi-Purpose Lawn and Garden Insect Killer
10	4	Rebels Supreme Blend Grass Seed for Sun and Shade
5	3	Rebels Supreme Blend Grass Seed for Sun and Shade
10	4	Ringer Lawn Restore 10-2-6
12.3	4.5	Sam's Choice Crabgrass Preventer 30-3-4
8.1	3	Sam's Choice Crabgrass Preventer 30-3-4
6	3	Sam's Choice Crabgrass Preventer 30-3-4
5.4	2.5	Sam's Choice Crabgrass Preventer 30-3-4
3	1.5	Sam's Choice Insect Control Plus Fertilizer 28-4-6
3.2	2	Sam's Choice Lawn Food 29-3-4
6	3	Sam's Choice Starter Fertilizer 20-27-5
3.6	2	Sam's Choice Starter Fertilizer 20-27-5
4	3	Scotts Classic Grass Seed Fall Grass Seed Mix
2	2	Scotts Classic Grass Seed Fall Grass Seed Mix
2.3	1.5	Scotts Grubex
3.1	2	Scotts Grubex Season Long Grub Control

lbs/1000 square feet	Flow Control Setting at 3 mph <sup>a</sup>	Materials <sup>b</sup>
2.3	2	Scotts Grubex Season Long Grub Control
1.4	1.5	Scotts Lawn Fungus Control
2.7	2	Scotts Lawn Fungus Control
2.2	2	Scotts Pure Premium Kentucky Bluegrass Mix
1.1	1.5	Scotts Pure Premium Kentucky Bluegrass Mix
2.5	2	Scotts Pure Premium Sun and Shade Grass Seed Mixture
1.25	1.5	Scotts Pure Premium Sun and Shade Grass Seed Mixture
3.6	2	Scotts Starter Fertilizer 20-27-5
5.9	2	Scotts Starter Fertilizer 20-27-5
2.7	2	Scotts Turf Builder 28-3-8
3.1	1.5	Scotts Turf Builder Lawn Fertilizer 29-3-4
2.7	2	Scotts Turf Builder with Summer Guard
2.9	2	Scotts Turf Builder Plus Weed Control
3.3	1	Scotts Winterizer 22-4-1
4.6	2	Sevin Lawn Insect Granules
2.33	2	Sevin Lawn Insect Granules
2.25	2	Sevin Lawn Insect Granules
3	2	Spectracide Grub Stop
3	1	Spectracide Traizicide Insect Killer Granules
3.6	2	Sta-Green Lawn Fertilizer 29-2-5
2	1.5	Sta-Green Lawn Weed Control
3.2	2	Sta-Green 200 Plus Weed and Feed 28-3-3
3.6	2	Sta-Green Starter Fertilizer 18-24-10
3.2	2	Sta-Green Weed and Feed 28-2-4
10	4	Sun and Shade Grass Seed Mixture
5	3	Sun and Shade Grass Seed Mixture
3	1	Vigoro Insect Control Plus Fertilizer
3.6	2	Vigoro Starter Fertilizer
3.2	2	Vigoro Turf Fertilizer 29-3-4
3	1.5	Vigoro Ultra Turf Winterizer 22-3-14
3.2	2	Vigoro Weed and Feed
4	3	Wal Mart Gardens Kentucky Bluegrass Grass Seed

# GETTING QUALITY SERVICE

lbs/1000 square feet	Flow Control Setting at 3 mph <sup>a</sup>	Materials <sup>b</sup>
2	2	Wal Mart Gardens Kentucky Bluegrass Grass Seed
8	4	Wal Mart Gardens Kentucky 31 Tall Fescue
4	3	Wal Mart Gardens Kentucky 31 Tall Fescue
3.2	2	Wal Mart Weed and Feed 28-3-3

a. Flow Control Settings are based on 3 mph forward speed.

b. The products listed are the property of their respective owners, and are not the property of, nor recommended by, Deere and Company.

## Calibration Settings

If the product you are using is not listed in the flow control setting table, use the this calibration guide to set the flow control. Calibration guide information is also provided on the hopper decal of the spreader.

Using application information on product package, find the calibration setting in the following guide and set calibration control lever.

Adjust spread pattern.

Calibration settings have been determined using a 3 MPH pace or 40 ft. of travel in 9 seconds.

### Calibration Guide for Flow Control Settings

lbs/1000 square feet	Flow Control Setting
0 - 1.9	1
2.0 - 2.9	1.5
3.0 - 4.9	2
5.0 - 6.9	2.5
7.0 - 8.9	3
9.0 - 10.9	3.5
11.0 - 12.9	4
13.0 - 14.9	4.5
15.0 - 17.5	5
17.6 - 19.5	5.5
19.6 - 21.5	6
21.6 - 23.5	6.5
23.6 - 25.5	7
25.6 - 27.9	7.5
28.0 - 29.9	8
30.3 - 33.4	9
33.5 - 36.0	10

## Getting Quality Service

### John Deere Quality Continues with Quality Service

John Deere provides a process to handle your questions or problems, should they arise, to ensure that product quality continues with quality parts and service support.

Follow the steps below to get answers to any questions you may have about your product.

1. Refer to your attachment and machine operator manuals.

2. In North America or Canada, call John Deere Special Services at 1-866-218-8622 and provide product serial number (if available) and model number.

# GETTING QUALITY SERVICE

---

---