

EVERBILT

TM

1.25 in. and 1.5 in. ABS Threaded ABS Sump Pump Check Valve



The Everbilt 1.25 in. and 1.5 in. ABS Threaded ABS Sump Pump Check Valve May be the world's most flexible sump pump check valve allowing for 18 different installation options.

This is the perfect valve for connecting a sump pump to a flexible plastic discharge hose.

Specifications

- **Valve Body:** Acrylonitrile butadiene styrene (ABS) thermoplastic

Store SKU #1001091723

Features and Benefits

- 1-1/4" & 1-1/2" shoulders for flexible coupling
- Check valve and coupling for flexible hose kit connection
- Barbed end for hose kit
- Dual threads for 1-1/4" or 1-1/2" discharge pump
- Strong, durable ABS
- Flow arrow molded onto valve
- Industry's most durable flapper

Dimensions

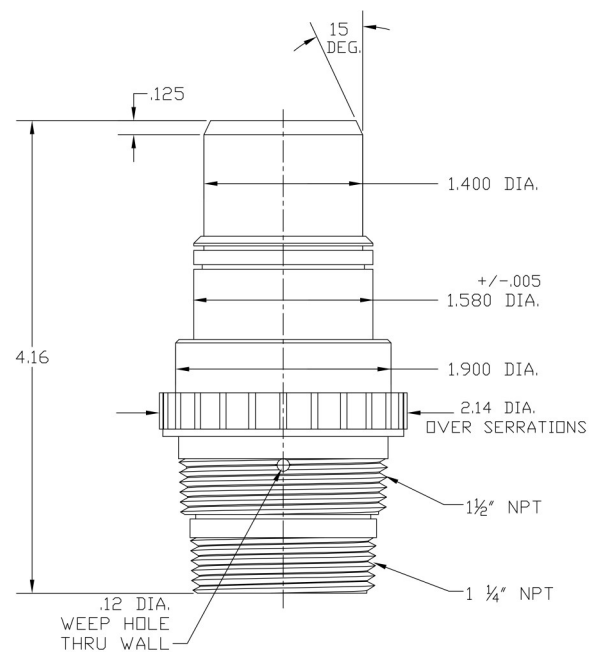

Please contact 1-877-297-6069 for further assistance • HOMEDEPOT.com

© 2018 Jackel, Inc.
EverbiltTHD1021, 06/18