

MODELS SE80T

Ultra Silent, High Performance, Attractive Design Grille

Description

Ventilating fan should be ceiling or wall mounted and capable of exhausting air quietly and efficiently. The SE series is HVI and ENERGY STAR certified.

It comes with a capacitor start motor which is known for its high efficiency and long lasting reliability. It holds an ETL evaluation and conforms to UL and cUL safety standards. This fan has a unique plug and play concept that allows you to add accessories such as motion sensor, humidistat, light, or even speed/controller without changing the fan.

Housing

Made of rugged 26 GA galvanized steel

Detachable 4 inch or 6 inch polymeric resin collar which includes a light weight built in back draft damper.

Double hanger bar mounting brackets that are adjustable up to 24 inch span allows for ideal positioning.

Motor/Blower

Plug in permanently lubricated motor- Engineered for continuous operation.

The motor is energy efficient and surpasses the minimum ENERGY STAR requirements for continuous duty operation.

Power rating should be 120 volts and 60 Hz

Fan shall be ETL and cETL listed for tub/shower enclosure when used with a GFCI branch circuit.

Motor comes with a built in overload disconnect for safety and longer motor life.

Our Premium series operates at lower RPM's to give you quieter operation.

Grille

The Premium grille is low profile that has elegance and still able to maintain its simplicity.

Made of a rugged polymeric resin that's known for its long life durability.

Comes with torsion spring clips that helps mount grille evenly.

Typical specification

Ceiling ventilator shall have corrosion resistance galvanized steel housing with 4 point mounting capability.

It shall be ducted to a roof vent or wall cap using 4 inch & 6 inch round pipe.

Blower assembly shall be removable, have a centrifugal type blower wheel and a permanently lubricated motor designed for continuous operation.

Air and sound delivery shall meet the HVI certified ratings as per the fan curves attached.

STERLING ventilators come with permanent split capacitor motor which improves efficiency this is why it has qualified to carry the ENERGY STAR label.



Optional
Humidistat
Motion Sensor
Speed control
Light Kit

Model Number	SE80T	
Static Pressure in inches w.g.	0.1	0.25
Air Volume (CFM)	80	58
Noise (sones)	0.4	N/A
Fan Watts	25W	
Duct Diameter	4" and 6"	
Power Rating (V/Hz)	120/ 60	

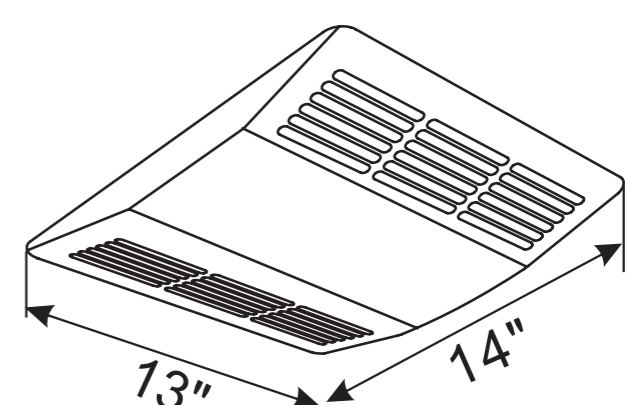
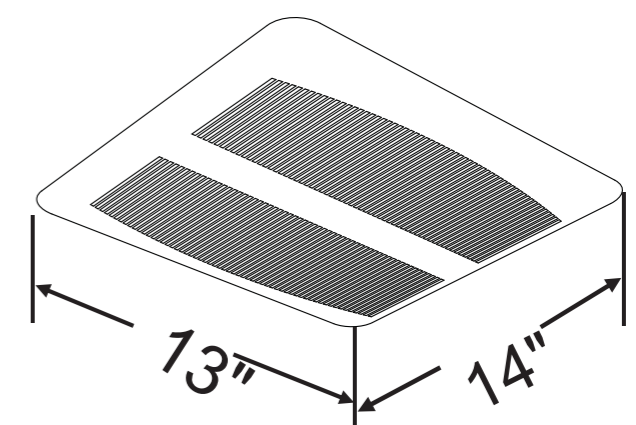
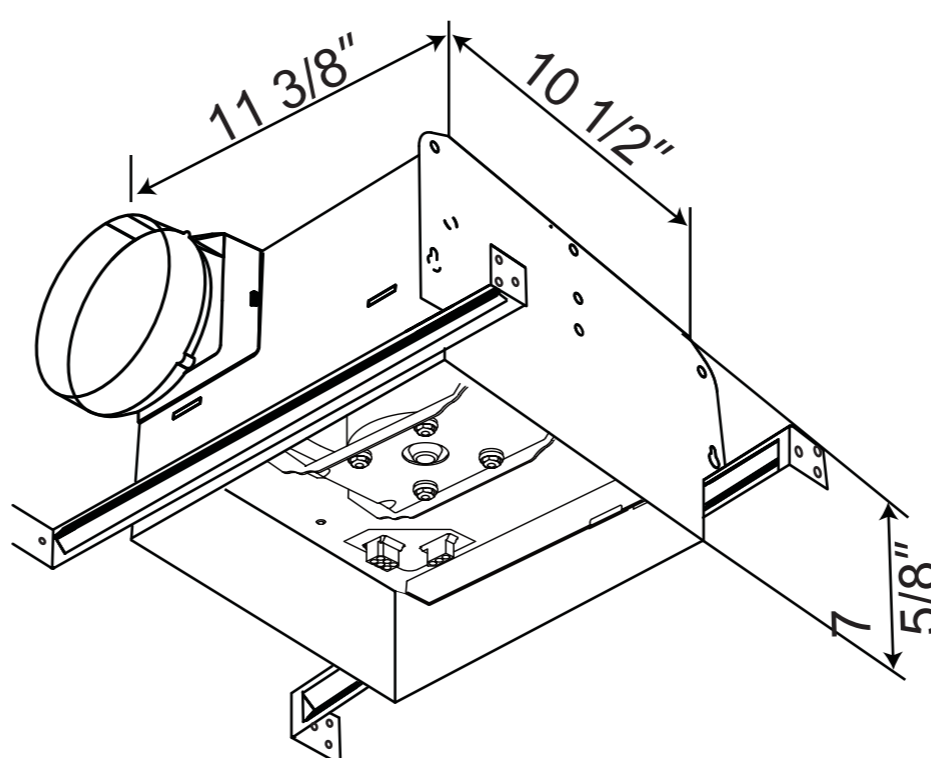

CERTIFICATIONS

