

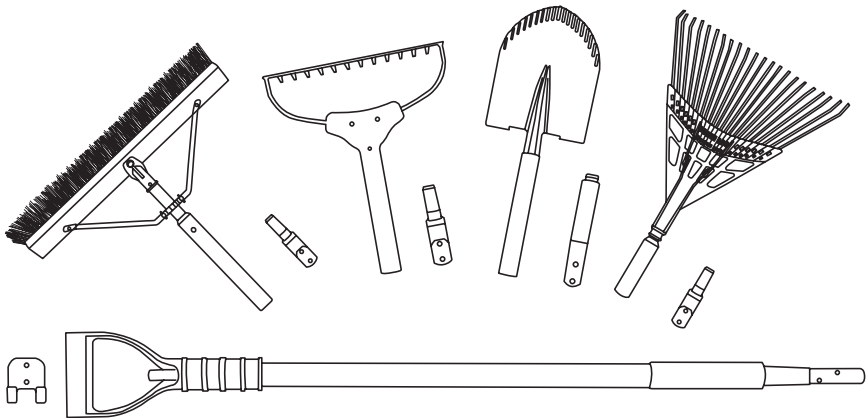

HANDLER MULTI-TOOL SYSTEM: GARDEN STARTER SET

Installation Quick Guide

Model SJ-HS101



Includes:

- SUN JOE Handler
- Steel blade round point shovel
- Metal garden rake
- Metal leaf rake
- 24-inch push broom
- 5 mounting brackets + hardware

If you have any questions or comments,
please call the Snow Joe® + Sun Joe® customer service department at:

1-866-SNOWJOE (1-866-766-9563)

© 2016 by Snow Joe®, LLC All rights reserved. Original instructions.
Handle + mounting brackets + locking sleeve: Made in U.S.A. | All other components: Made in China

SAVE THESE INSTRUCTIONS

Connecting Interchangeable Heads

1. Press down the release button (Fig. 1).

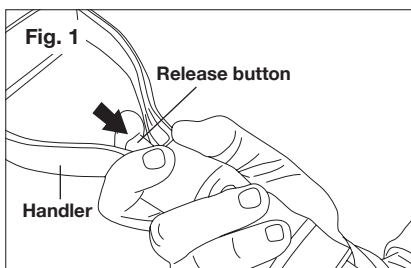

2. Install tool attachment (tool head) on the SUN JOE Handler.

- The release button (located in the handle) must be held down while installing the attachment.
- The flats on the Handler tip must be aligned with the flats on the attachment socket in order for the Handler to be fully engaged and work properly (Fig. 2).

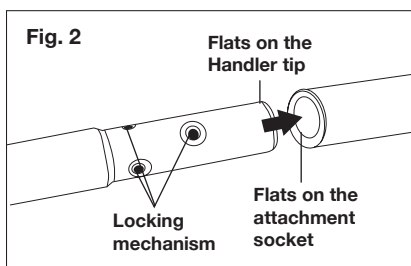

- To align the flats, simply twist the attachment while installing. The attachment will bottom out on the handle when the flats are properly aligned and prevent the attachment from rotating (Fig. 3).

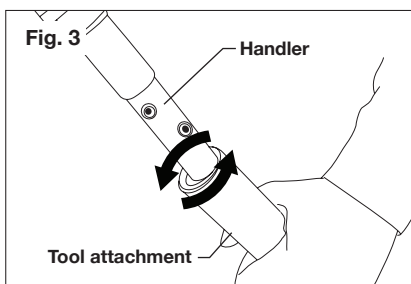

⚠ CAUTION! Do not push the release button while using the SUN JOE Handler. Doing so could cause the attachment to become disconnected and serious injury could result.

SUN JOE Handler Care

1. For optimal performance it is important to keep the locking tip and attachments free of dirt and debris.

Locking Tip: Rinse the locking tip with water. **DO NOT PUSH THE RELEASE BUTTON.** Doing so could result in debris getting into the ball joints impeding the performance of the locking tip mechanism.

Attachments: To remove debris, rinse attachments with water.

Removing Interchangeable Heads

1. Press down the release button (located in the handle) (Fig. 4).

NOTE: The locking mechanism is designed to be engaged at all times and is only deactivated when the release button is pressed.

2. Grasp tool attachment firmly, and remove (Fig. 4).

NOTE: The release button must be held down while removing the attachment.

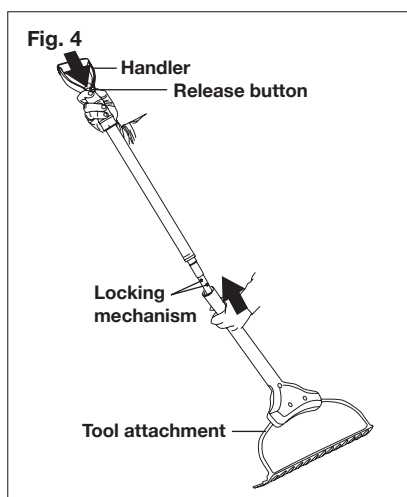

Wall Mount Assembly

1. Remove the wall mounts and screw pack from the packaging and locate stud on the wall.
2. Position wall mounts on stud as shown. Drill screws into stud. Be sure to allow enough space between the mounts to insure that the head attachments will not interfere with each other (Fig. 5).
3. Insert attachments into mounts (Fig. 5).

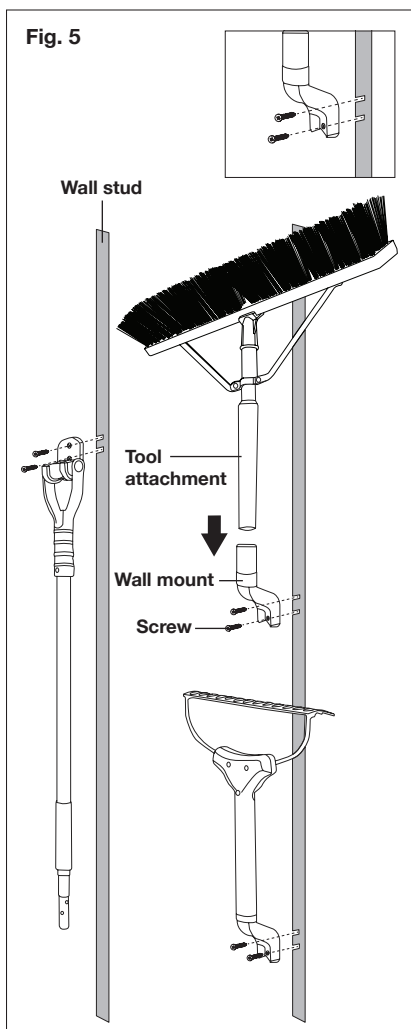

⚠ WARNING! Some dust and debris created by the use of the tool could contain chemicals known to the State of California to cause cancer and birth defects or other reproductive harm. Some examples of these chemicals are:

- chemicals in fertilizers
- compounds in insecticides, herbicides, and pesticides
- arsenic and chromium from chemically treated lumber

Your risk from exposure to these chemicals varies, and depends on how often you do this type of work. To reduce your exposure, work in a well-ventilated area and with approved safety equipment, such as dust masks that are specially designed to filter out microscopic particles.

NOTE: If you have any questions, please call the Snow Joe® + Sun Joe® customer service department at 1-866-766-9563 for assistance.

Service + Support

If your SUN JOE® SJ-HS101 HANDLER MULTI-TOOL SYSTEM: Garden Starter Set requires service or maintenance, please call the Snow Joe® + Sun Joe® customer service center at 1-866-SNOWJOE (1-866-766-9563).

Model + Serial Numbers

When contacting the company, reordering parts, or arranging service from an authorized dealer, you will need to provide the model and serial numbers, which can be found on the decal located on the handle of the unit. Copy these numbers into the space provided below.

Record the following numbers from the housing or handle of your new product:

Model #:

S | J | - | H | S | 1 | 0 | 1

Serial #:



SNOW JOE® + SUN JOE® CUSTOMER PROMISE

ABOVE ALL ELSE, Snow Joe® + Sun Joe® are dedicated to you, our customer. We strive to make your experience as pleasant as possible. Unfortunately, there are times when a product does not work or breaks under normal operating conditions. We think it's important that you know what you can expect from us. That's why we created the Snow Joe® + Sun Joe® promise.

OUR PROMISE: Snow Joe® + Sun Joe® warrant new products for two years from the date of purchase. If your product does not work, or there's an issue with a specific part, we will fix this by either sending you a free replacement part or by sending you a new or comparable product at no charge. How cool is that! Before you know it, you'll be back in action cutting, sawing, mowing, washing and...?

GENERAL CONDITIONS:

Snow Joe® + Sun Joe® operating under Snow Joe®, LLC warrants this new product to the original purchaser for two years against defects in material or workmanship when used for normal residential purposes. If a replacement part or product is needed, it will be sent free of charge to the original purchaser except as noted below.

The duration of this warranty applies only if the product is put to personal use around the household. If the product is put to any business, commercial or industrial use or is rented or leased, then the duration of this warranty is 90 days from the date of original purchase. It is the owner's responsibility to correctly perform all maintenance and minor adjustments explained in the owner's manual.

HOW TO OBTAIN YOUR REPLACEMENT PART OR PRODUCT:

To obtain a replacement part or product, please visit snowjoe.com/help or email us at help@snowjoe.com for instructions. Please be sure to register your unit beforehand to speed up this process. Failure to register your product purchase will not diminish your warranty rights. Certain products may require a serial number, typically found on the decal affixed to the housing or guard of your product. All products require a valid proof of purchase.

EXCLUSIONS:

- Wearing parts like belts, augers, chains and tines are not covered under this warranty. Wearing parts can be purchased at snowjoe.com or by calling 1-866-SNOWJOE (1-866-766-9563).
- Batteries are covered in full for 90-days from the date of purchase.

Snow Joe® + Sun Joe® may from time to time change the design of its products. Nothing contained in this warranty shall be construed as obligating Snow Joe® + Sun Joe® to incorporate such design changes into previously manufactured products, nor shall such changes be construed as an admission that previous designs were defective.

This warranty is intended to cover product defects only. Snow Joe®, LLC is not liable for indirect, incidental or consequential damages in connection with the use or misuse of the Snow Joe® + Sun Joe® products covered by this warranty. This warranty does not cover any cost or expense incurred by the purchaser in providing substitute equipment or service during reasonable periods of malfunction or non-use of this product while waiting for a replacement part or unit under this warranty. Some states do not allow exclusions of incidental or consequential damages so the above exclusions may not apply in all states. This warranty may give you specific legal rights in your state.

HOW TO REACH US:

We're here to help Monday through Friday from 9AM to 6PM EST. You can reach us at 1-866-SNOWJOE (1-866-766-9563), online at snowjoe.com, via email at help@snowjoe.com or tweet us @snowjoe.

EXPORTS:

Customers who have purchased Snow Joe® + Sun Joe® products exported from the United States and Canada should contact their Snow Joe® + Sun Joe® distributor (dealer) to obtain information applicable to your country, province or state. If for any reason, you are not satisfied with the distributor's service, or if you have difficulty obtaining warranty information, contact your Snow Joe® + Sun Joe® seller. If in the event your efforts are unsatisfactory, please reach out to us directly.