



WELCOME TO THE CLUB

THE FIRE & SMOKE SOCIETY

Since the dawn of history, people of all cultures have gathered around the fires and fanned the smoke of friendship to share great food and build community. The

Fire & Smoke Society is our brotherhood of family, friends, neighbors, foodies, cooks, pit masters, dungeon masters and BBQ enthusiasts. As one, we share in the noble endeavor to cook over open flame, the beasts, fish and fowl of our daily harvest, for the pure pleasure of our companions and of this Society.

GO FORTH AND GRILL.

FEATURES

4-POINT VENTING SYSTEM™

The fully configurable 4-Point Venting System™ on the new PK360 is revolutionary in precision air control and heat management. Combined with its unique shape, the PK360 is ideally suited to both direct and indirect cooking, often called 2-zone cooking. The 4-point system provides exceptional air flow throughout the grill capsule. Keeping consistent heat on a charcoal grill has never been easier.



FEATURES

THE UNIQUE PK GRILL CAPSULE

The PK360 is superior to round grills for direct and indirect cooking. This maximizes your cooking space, makes 2-zone set ups easy and allows for superior air flow when indirect cooking.

DIRECT HEAT (1 ZONE)



DIRECT HEAT (2 ZONE)

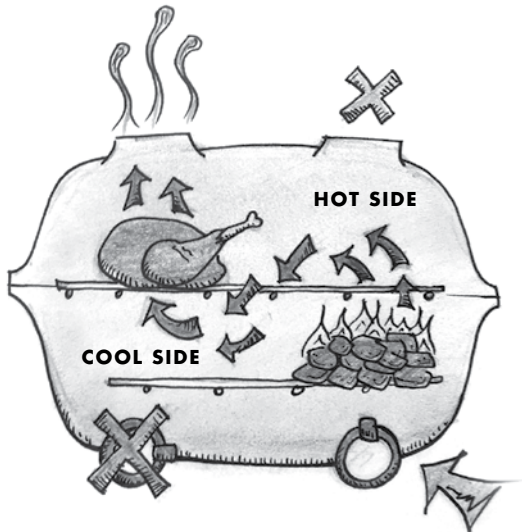

FEATURES

BEAUTIFUL DESIGN & RUGGED MATERIALS

DIMENSIONS & CAPACITY

HEIGHT	42.5"
WIDTH	54" (FROM SHELF TIP TO TIP)
DEPTH	23.75"



FEATURES



360 SQUARE INCHES OF COOKING SURFACE

Plenty of space for a pork shoulder, roasted chicken, a rack of ribs or anything else you can think of. That's almost 100 more inches than a large Big Green Egg and 60 more than a Primo L300.



REMOVABLE MARINE GRADE STAINLESS HINGED COOKING SURFACE

Marine grade stainless is the pinnacle of stainless cooking surfaces. The hinged grid is a hallmark of the PK experience, but this new surface adds the ability to remove the door completely for quick & easy refueling. A little trick we picked up from some of our professional customers.



THE HINGES ARE CAST TOO

What can we say, this is another PK hallmark. Cast in hinges still means fewer parts to rust or break. This is a newly designed, more stable hinge with twice as many contact points to ensure the PK Top Cast stays well seated in every position.



CARRY HANDLES

With the shelves detached, your PK is ready for adventure. Carry it to the truck with these sturdy handles, pack up the dog and hit the road.



REAR UTILITY HOOKS

These handy little hooks do double duty. They are great place to hang your shelves, an ash bucket or a set of tools. They also serve as stabilization points when you use your PK without the stand. You can open the Top Cast and the grill won't rock back. *Always use your PK on non-flammable surfaces.

FEATURES

ASH MANAGEMENT SYSTEM

The PK360 has incorporated a unique ash management solution which controls ash within the cook chamber using high walled air intakes and covers, combined with a large opening at the rear of the capsule for easy clean-up and disposal.

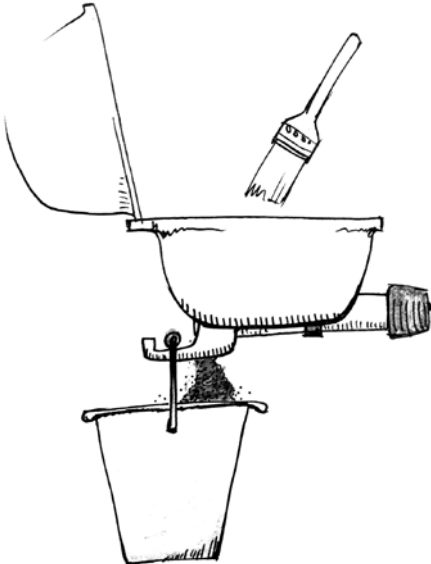
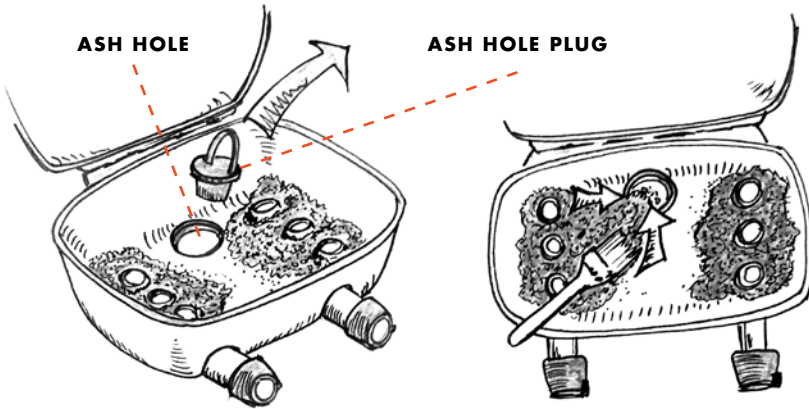

PARTS

STEP
1

OPEN BOXES.

Remove all grill components and take inventory of the following parts:

TOOLS NEEDED: Philips Head Screwdriver

01. Top Cast

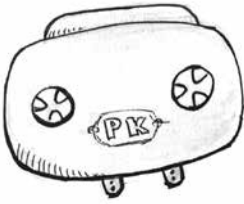

02. Bottom Cast



03. Control Tower Tube



04. Control Tower Base

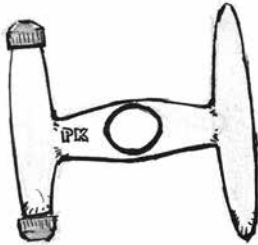

05. Grids & Grates

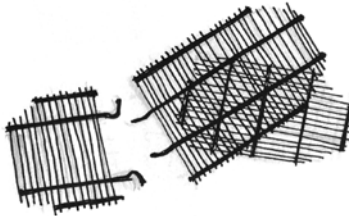

06. Front Handle



07. Side Handle



08. Lower Air Intake
Cylinders

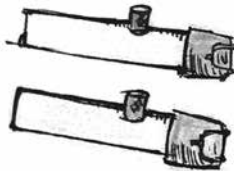

09. Quick Release
Knob



09. Shelves

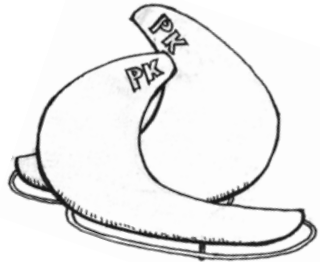

10. Ash Roofs

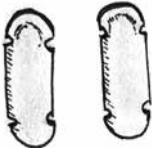

11. Ash Plug



12. Tel-Tru
Thermometer



13. Hex Wrench



ASSEMBLY INSTRUCTIONS

STEP
2

ASSEMBLE CONTROL TOWER™ TUBE TO BASE:

- 1) Place Control Tower™ Base flat, right side up on a level surface with the wheels on your left. Twist the adjustable feet as needed to balance and stabilize the Base.
- 2) Orient the Control Tower™ Tube so the tab on the bottom of the tube is facing toward you. Slide the Tube down through the hole in the Base into the Mount Cuff until the tab fits into the slot on the Mount Cuff.
- 3) Holding the Tube and Base together, turn the assembly over and rest it on the tube with the bottom of the Base facing upward. Verify that the Tube tab is flush in the Mount Cuff slot.
- 4) Using the provided hex wrench, tighten each of the four bolts on the bottom of the Mount Cuff one at a time in a circular pattern until hand tight. Repeat tightening in a circular pattern until all bolts are hand tight. Do not over tighten.
- 5) Set aside.

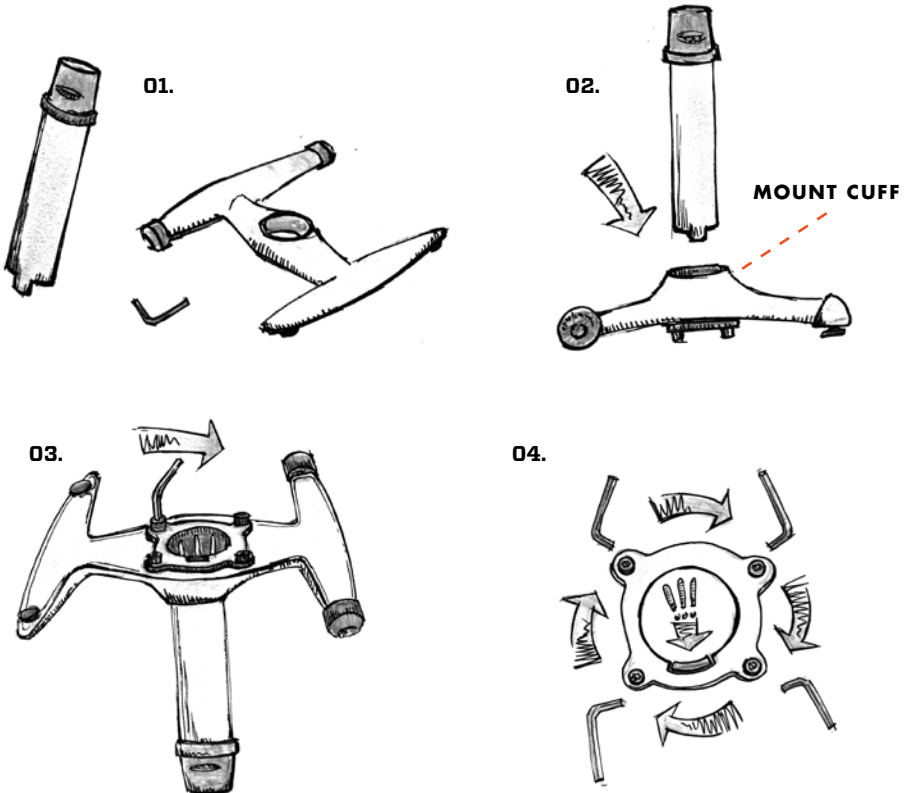

ASSEMBLY INSTRUCTIONS

STEP
3

**MOUNT BOTTOM CAST TO CONTROL TOWER™ TUBE.
SECURE IN PLACE BY TIGHTENING QUICK RELEASE KNOB.**

- 1) With the control tower quick release off, place the Bottom Cast on Control Tower™.

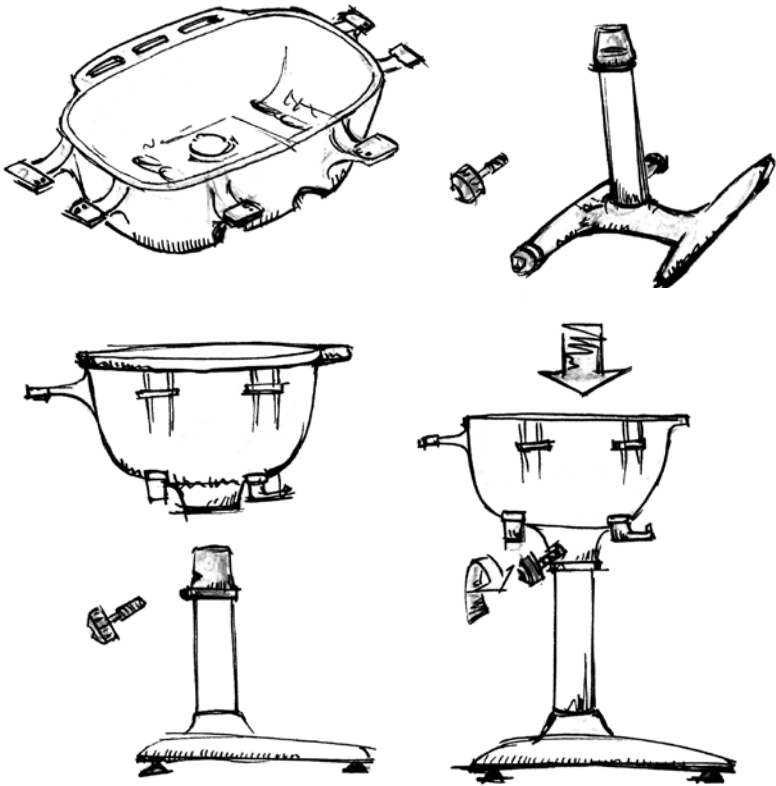

- 2) With the control tower quick release off, place the Bottom Cast on Control Tower™. Tighten the Quick Release Knob to secure the Bottom Cast to Control Tower™.

ASSEMBLY INSTRUCTIONS

STEP
4

ASSEMBLE COMPONENTS OF BOTTOM CAST AS FOLLOWS:

- 1) Assemble left side handle with hook facing out from Grill Bottom Cast. Repeat with right handle.
- 2) Place one Air Intake tube (Both Left and Right Intake Tubes are the same) into left Air Intake Slot on Grill Bottom Cast as shown. Hand tighten Thumb Screw into hole on Air Intake Tube to secure in proper position. Air intake tube should be able to turn 90 degrees when Thumb Screw is installed properly. Indicator on Air Intake Knob should point up when Air Intake tube holes are in fully open position and point to the right when Air Intake tube holes are in the fully closed position. Repeat with right Air Intake Tube.

HOOK

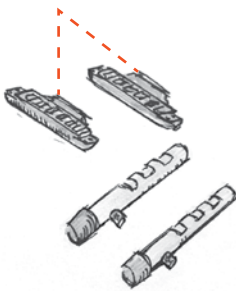

01.

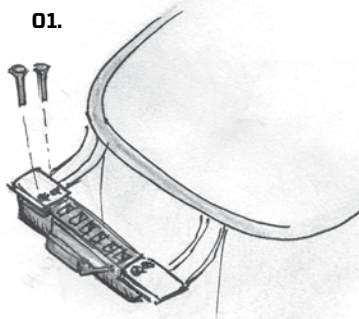

02.

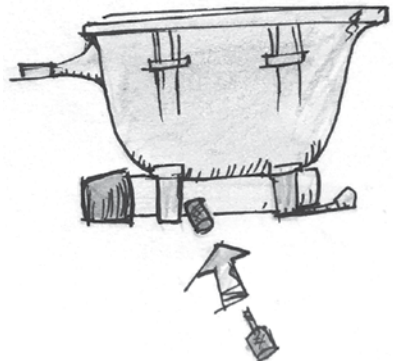
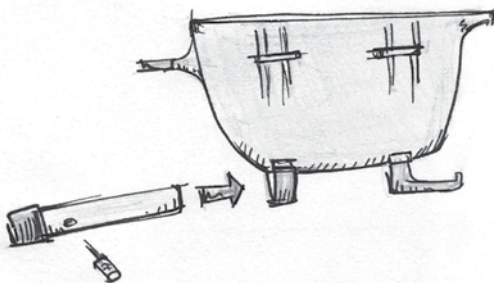

ASSEMBLY INSTRUCTIONS

STEP
5

ASSEMBLE TOP CAST AS FOLLOWS:

- 1) Place Top Cast flat on Bottom Cast, oriented as shown in picture. The Top Cast is held in place by the tabs along the back side and gravity. There is no hardware required to secure the Top Cast in place. Pretty Clever, we know.
- 2) Open and close Top Cast to make sure hinge is oriented properly.
- 3) With top open, assemble front Handle using screws and inserts provided.
- 4) Assemble Tel-Tru Thermometer and Thermometer Housing using wing nut.

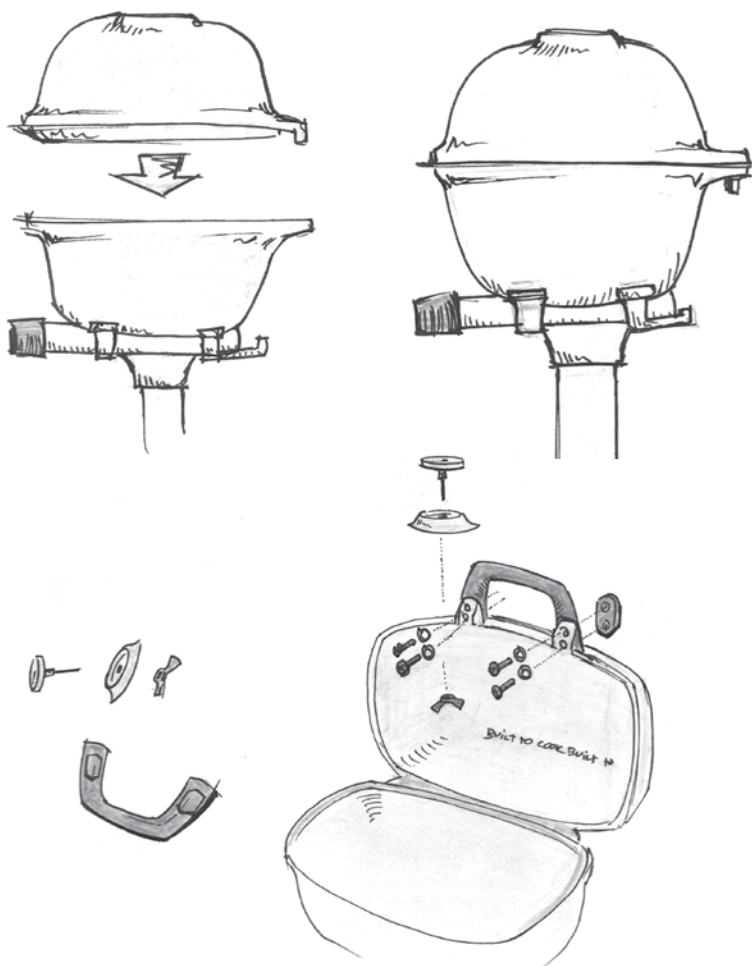

ASSEMBLY INSTRUCTIONS

STEP
6

ATTACH SHELVES TO GRILL:

- 1) Each shelf has three knobs on the bottom that align with three shelf mount tabs on the Grill Bottom Cast.
- 2) With knobs on the bottom of the shelves loose, slide shelves on horizontally until shelves engage with shelf mount tabs.
- 3) Hand tighten knobs.

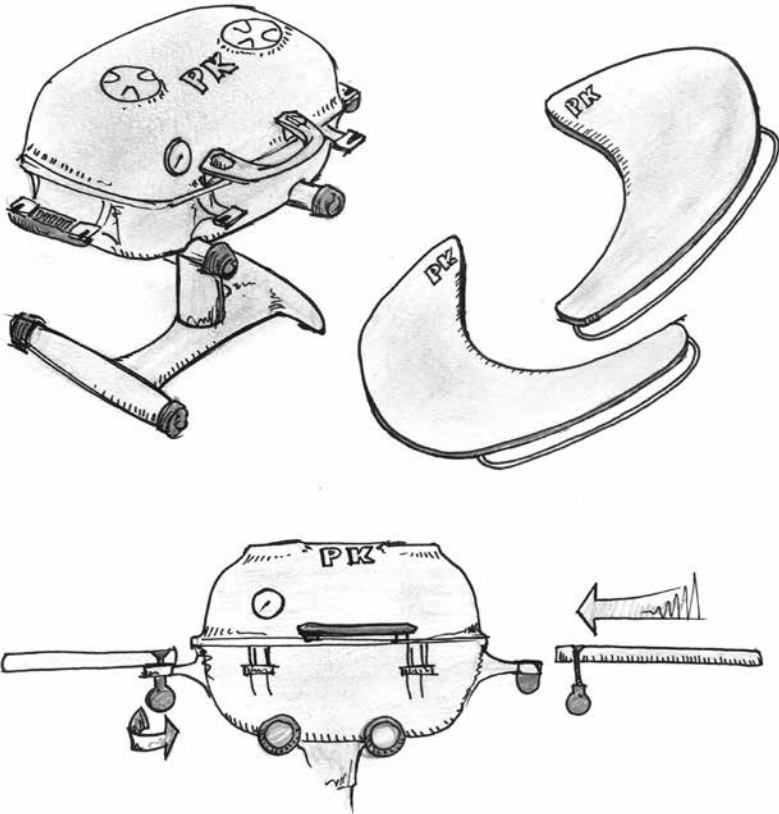

ASSEMBLY INSTRUCTIONS

STEP
7

NOW GET READY TO GRILL:

- 1) Place removable Ash Hole Cover in hole in Grill Bottom Cast.
- 2) Place removable Ash Roofs on top of the air intake holes in the Grill Bottom Cast.
- 3) Place Stainless Steel Charcoal Grate on side mounts in the Grill Bottom Cast. ADD CHARCOAL.
- 4) Place Stainless Steel Cooking Surface on left side of Grill Bottom Cast on side mounts.
- 5) Link Stainless Steel Cooking Surface Door on right side of Grill Bottom Cast and allow to rest on side mounts as shown. ADD TOMAHAWK STEAKS.



TOMAHAWK STEAKS

USAGE, CLEANING & CARE

FIRING UP YOUR PK

- Rotate the air intake tubes to the full open position.
- Fill one charcoal chimney with briquettes and light the chimney as per the instructions.
- Once the coals are hot (clear smoke, white appearance) Open the hinged side of the cooking grid or remove the grid completely and dump the hot charcoal onto the charcoal grate.
- For two-zone cooking, arrange the coals on one side of the grill. This side will be your hot zone. The other side will be your cool zone.
- Close the door on the cooking grid or put the cooking grid into place.
- Close the Top Cast and set the radial exhaust vents to dial in your desired cooking temperature.
- This process may be used with one or two charcoal chimneys depending upon your method of cooking and how much fuel you need.
- Special note: We declare the area inside a 5-foot radius of any PK Grill to be the “Cool Zone.” That’s right. We just said that.

COOLING DOWN YOUR PK

- Closing the Top Cast and all of the vents will starve the coals of oxygen and shut down the grill.
- Because the PK is so efficient, it shuts down quickly and you may find that you have left over coals after your cook. These coals can be re-lit and re-used.
- Make sure the coals are completely cool before attempting to clean ash out of your PK. Never dispose of hot ash in any area with flammable materials.
- A PK Charcoal basket will keep your coals together, aid in reuse and clean-up.

PRO TIP



A CLEAN GRILL COOKS MORE EVENLY

Cleaning your PK360 Grill & Smoker is easy. Once the ashes inside the grill are cool, simply remove the plug from the Ash Hole™, hang a metal bucket from the rear utility hooks or set one on the ground and brush the ashes into the hole. Air Intake Cylinders™ can be removed easily for cleaning. For a more thorough cleaning, remove the entire capsule from its base and hose it out.

USAGE, CLEANING & CARE

GRILLING, HOT & FAST, THE DIRECT METHOD

Start the fire as indicated above, and let the coals get up to temperature. Crack open a beverage. Smile.

- If you would like to set-up two “zones,” as many chefs prefer, ensure the coals are on one side of the capsule and that the cooking surface is installed so that the hinged opening is over the coals.
- Close the Top Cast and open all of the vents. Wait a few minutes to allow PKs aluminum cast to warm up and then take a temperature reading. The stock Tel-Tru thermometer is highly accurate +/- 1%.
- If you prefer a lower temperature, adjust the Intake. Close the lower Air Intake to reduce the incoming oxygen and bring the temperature down as needed. Note: if your smoke looks thick and dirty, your coals are not getting enough oxygen. Open the lower vents. Good smoke is thin and almost clear.
- Once your PK has reached the desired temperature, throw some meat on it.
- Your PK is designed to cook best with the Top Cast closed. Keeping your Top Cast closed while cooking will allow you to cook at a very high heat without fire flaming up and burning the meat as typically happens in other outdoor cookers.
- If you get a flame-up, briefly close the Top Cast and the top vents to extinguish it.

BARBECUE, LOW & SLOW, THE INDIRECT METHOD

- Start the fire as indicated, and let the coals get up to temperature. Crack open a beverage. Smile.
- Set up the grill for two zone cooking. Place the coals on one side of the charcoal grate and place a drip pan on the other side.
- Close the Top Cast and configure the vents as follows. Rotate the vent tube beneath the hot coals to the fully open position. Rotate the other vent tube to fully closed. Close the radial exhaust vent above the hot coals. Open the other radial exhaust vent.
- Wait a few minutes to allow PKs aluminum cast to warm up and then take a temperature reading. The stock Tel-Tru thermometer is highly accurate +/- 1%. If the temperature is too high, close Air Intake Cylinder slightly, wait a few minutes and re-check. If the temperature is too low, open the other (closed) vent tube slightly to allow more oxygen in, wait a few minutes and re-check.
- Place your meat on the cool side of this set-up. Refuel as needed.

WARRANTY



-
- 1) We stand behind this product. If you are not entirely satisfied with your new PK Grill & Smoker, we want to know about it. Do not return to the retailer where you purchased it. Contact us immediately to resolve the issue. customerservice@pkgrills.com or 1 (866) 354-7575
 - 2) Immediately register your new grill online: www.pkgrills.com/warranty-registration
 - 3) Portable Kitchens, Inc. hereby warrants to the original purchaser this new “Portable Kitchen” grill and smoker to be free from defective material or workmanship at the time of purchase. Any defect must be brought to the attention of Portable Kitchens, Inc. within thirty (30) days from the date of purchase. Portable Kitchens, Inc. will replace free of charge to the purchaser any part or parts.
 - 4) Portable Kitchens, Inc. further warrants the cast aluminum grill capsule against burn-out, rust or breakage for a period of ten (10) years from the date of purchase under normal non-commercial use. This warranty is between the purchaser and Portable Kitchens, Inc. Should any of the above conditions occur, Portable Kitchens, Inc. will repair or replace parts affected free of charge to the purchaser provided a warranty card or online registration is on file with Portable Kitchens, Inc. All postage or freight to the factory will be the responsibility of the purchaser.
-

**BUILT TO COOK.
BUILT TO LAST.**



WARNINGS

- 1)** Failure to follow the warnings contained in this Owner's Manual may result in damage to your PK Grill, your property, serious bodily injury or death.
- 2)** NEVER burn charcoal inside homes, vehicles or tents or any semi-enclosed area including garages, breezeways or balconies. Always grill in a well ventilated area.
- 3)** Burning charcoal indoors can kill you. It releases carbon monoxide, which is an odorless gas that can cause serious injury or death.
- 4)** Do not use the PK360 unless it is properly assembled and all parts are in place. It is your responsibility to exercise reasonable care when using your PK Grill. Never leave a hot grill unattended.
- 5)** The grill capsule of your PK360 is made of an aluminum alloy with a melting point of 1080 degrees. Do not exceed this threshold by using blow torches, excessive amounts of lighter fluid or other accelerants like gasoline or alcohol to start your grill. PK recommends using a charcoal chimney to start your grill.
- 6)** If you use starter fluid, be sure that no excess fluid has pooled inside or outside the grill before starting your grill.
- 7)** The lower charcoal grate must always be in place. Never put hot coals directly on the aluminum cast as this could cause damage to the cast.
- 8)** The outer surface of the PK360 gets extremely hot while cooking. Barbecue mitts should always be worn while cooking, adjusting the air vents, adding charcoal and handling the Top Cast.
- 9)** Be extremely careful around the PK when it is in use. Do not allow small children around this or any other grill that has burning charcoal in it. It is your obligation to supervise children who are in the vicinity of a hot grill. Failure to do so may result in injury or death.
- 10)** Make sure your PK360 is always on a soTop Cast, level surface when in use. Do not use this barbecue within five feet of any combustible material. Combustible materials include, but are not limited to wood or treated wood decks, patios and porches. Do not use on grass.
- 11)** Do not attempt to move a hot grill. Do not wear loose clothing that could catch fire when operating a grill.
- 12)** Do not remove ashes until all charcoal is completely burned out and are fully extinguished and grill is cool.
- 13)** Never dump hot coals where they might be stepped on or be a fire hazard. Never dump ashes or coals before they are fully extinguished. Do not store barbecue until ashes and coals are fully extinguished.
- 14)** Never use the PK360 without the ash hole plug, ash roofs and Air Intake Cylinders™ properly installed. Failure to do so may allow hot ash to escape from the grill.



PRO TIP



KEEP EVEN HEAT

"Cooking at 225°F will allow meat to roast low and slow, liquefying the collagen in connective tissues and melting fats without getting the proteins knotted in a bunch. It's a magic temp that creates silky texture, adds moisture, and keeps the meat tender. If you can't hit 225°F, get as close as you can. Don't go under 200°F and try not to go over 250°F" - Meathead Goldwyn

LAST MEAL RIBS

This is the recipe for making the best barbecue ribs you ever tasted.

Recipe by Meathead Goldwyn

INGREDIENTS

- 1 slab of fresh St. Louis Cut Ribs
- 4 tablespoons of Meathead's Memphis Dust**
- 1/2 teaspoon kosher salt* per pound of meat
- 1 cup of your favorite barbecue sauce

*Note: Kosher salt is 1/2 the concentration of table salt. If you use table salt, cut it by 1/2.

**Find it at amazingribs.com

MAKES

1 slab, enough for 2 adult servings

PREPARATION TIME

15 minutes minimum. 10 minutes to skin 'n' trim, 5 minutes to rub, 1 to 2 hours dry brining is optional. Cooking time. 3 hours minimum. We will be cooking low and slow at about 225°F, so allow 5 to 6 hours for St. Louis Cut (SLC) ribs and 3 to 4 hours for baby back ribs. Thicker, meatier slabs take longer, and if you use rib holders so they are crammed close to each other, add another hour.

DIRECTIONS

- 1) Rinse.** Rinse the ribs in cool water to remove any bone bits from the butchering and any bacterial film that grew in the package (don't worry, cooking will sterilize the meat).
- 2) Skin n' trim.** If the butcher has not removed the membrane from the under side, do it yourself. It gets leathery and hard to chew, it keeps fat in, and it keeps sauce out. Insert a butter knife under the membrane, then your fingers, work a section loose, grip it with a paper towel, and peel it off. Finally, trim the excess fat from both sides. If you can't get the skin off, with a sharp knife, cut slashes through it every inch so some of the fat will render out during the cooking.
- 3) Salt.** Salt is important. Even if you are watching your salt intake, a little salt really helps. It penetrates deep and amplifies flavor. It helps proteins retain moisture. And it helps with bark, the desired crust on the top formation. If you can, give the salt 1 to 2 hours to be absorbed. The process of salting in advance is called dry brining. The rule of thumb is 1/2 teaspoon of kosher salt per pound of meat, but ribs are about 50% meat, so use about 1/4 teaspoon per pound. You can simply eyeball it by sprinkling on the same amount of salt you would sprinkle on the ribs if they were served to you unsalted. If time permits, get the salt on about 1 to 2 hours before cooking.

LAST MEAL RIBS

- 4) **Rub.** Then coat the meat with a thin layer of water. The water helps dissolve the spices. Sprinkle enough Meathead's Memphis Dust to coat all surfaces but not so much that the meat doesn't show through. That is about 2 tablespoons per side depending on the size of the slab. Spread the Memphis Dust on the meat and rub it in. Some folks insist on putting the rub on the night before, but it isn't necessary.
- 5) **Set up your PK for Indirect Cooking** (see pg. 02)
- 6) **Adjust the temp.** Preheat your PK to about 225°F and try to keep it there throughout the cook. Adjust the air intake dampers at the Bottom Cast to control heat. Intake dampers are more effective than exhaust dampers for controlling the temp because they reduce the supply of oxygen to the coals. Take your time getting the temp right. Cooking at 225°F will allow the meat to roast low and slow, liquefying the collagen in connective tissues and melting fats without getting the proteins knotted in a bunch. It's a magic temp that creates silky texture, adds moisture, and keeps the meat tender. If you can't hit 225°F, get as close as you can. Don't go under 200°F and try not to go over 250°F.
- 7) **Add 4 ounces of wood at this time.** Put it right on the hot coals. Resist the temptation to add more wood. Nothing will ruin a meal faster and waste money better than over smoked meat. You can always add more the next time you cook, but you cannot take it away if you over smoke.
- 8) **More smoke.** When the smoke dwindles after 20 to 30 minutes, add another 4 ounces of wood. That's it. Stop adding wood. If you have more than one slab on, halfway through the cook you will need to move the ribs closest to the fire away from the heat, and the slabs farthest from the flame in closer. Leave the meat side up. There is no need to flip the slabs. You can peek if you must, but don't leave the Top Cast open for long.
- 9) **The Texas Crutch.** This trick involves wrapping the slab in foil with about an ounce of water for up to an hour to speed cooking and tenderize a bit. Almost all competition cooks use the crutch to get an edge. But the improvement is really slight and I never bother for backyard cooking. If you crutch too long you can turn the meat to mush and time in foil can soften the bark and remove a lot of rub. I recommend it only for competition when the tiniest improvement can mean thousands of dollars. Skip it and you'll still have killer ribs. But if you've seen it on TV and must try it, [click here to learn more about The Texas Crutch.](#)

REFERENCE

FIGURE A: PORK CUTS

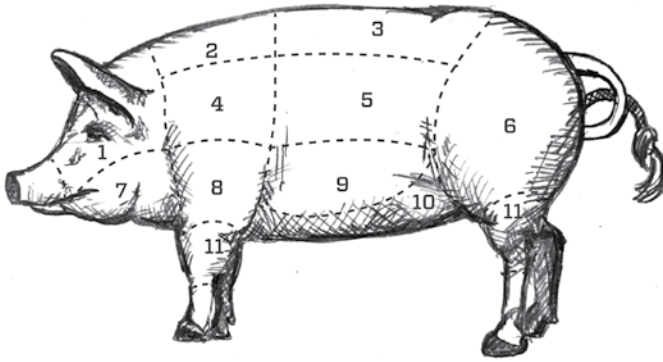

1	HEAD	7	CHEEK
2	CLEAR PLATE	8	PICNIC
3	BACK FAT	9	RIBS
4	BOSTON SHOULDER	10	BACON
5	LOIN	11	HOCK
6	LEG		

FIGURE B: RIB CUTS

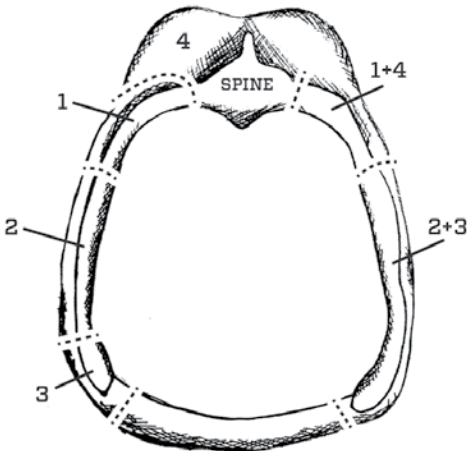

1	BABY BACK
2	ST. LOUIS CUT
3	RIB TIPS
4	LOIN MEAT
2+3	SPARE RIBS
1+4	RIB ROAST



PRO TIP



USE GOOD, DRY WOOD

When cooking with wood the quality of your wood is as important as the quality of your meat. Use dry wood. Soaked wood burns longer, but the smoke is less clean. Try Hickory. It's good with pork, ham and beef and great for bacon. Use a little hickory at the beginning of longer cooks like brisket and pork butts, and a small amount of hickory chips/chunks for short cooks. Too much hickory can bitter out your meat and add too much smoke. Smoke Note: thin and blue = tasty. Thick and white = bitter.

SMOKED BACON

Recipe by Jess Pryles of jesspryles.com

INGREDIENTS

- 3lb skinless, boneless pork belly
- 3 tablespoons kosher salt
- 1/3 cup white sugar
- 2 tablespoons pepper
- 2 teaspoons paprika
- 1 teaspoon pink curing salt (aka Prague Powder #1)
- Wood chunks, such as Apple or Hickory.

PREPARATION TIME

*Seven Days,
Three Hours and
Worth the Wait!*

- 1) CURING.** To start, cure the belly. In a small bowl, combine the pepper, sugar, paprika, salt & curing salt. Place belly on a foil lined tray and pat dry with paper towels. Using half of the cure mix, sprinkle evenly over the surface of the belly, and rub in gently. Turn over and repeat on other side with remaining mix. Place the entire belly and curing mix into a large zip top bag and place in refrigerator for 7 days. Each day the belly should be flipped onto the other side, and the contents (which will transform to a liquid) should be massaged around.
- 2) WAITING.** After 7 days, remove from the bag and rinse under water. Pat dry with paper towels, and place back in fridge uncovered (on a rack over a pan to catch any drips) for 24 hours.
- 3) GRILLING.** Prepare your PK grill for indirect two-zone cooking. Place a foil tray of water on the right hand side of the lower grate, and about 8-10 ashed briquettes on the left hand side. Ensure the opening of the top grate is over the coals so you can replenish with ease. Close all vents 2/3rds closed, place 1 chunk of wood on the coals, and place the belly on the upper grate above the water pan, then close the Top Cast. Check the fire every 30 minutes or so, adding more lit briquettes and wood chunks as needed. The temperature should not exceed 200f. Smoke for approximately three hours, or until the internal temp reaches 150f.
- 4) STORAGE.** Store bacon in an airtight plastic bag or container in refrigerator for up to a week, cutting and cooking as required.

VISIT PKRGRILLS.COM FOR MORE RECIPES

PK ACCESSORIES & GEAR



01. Tongs



02. Spatula



03. Rib Rack



04. Charcoal Basket



05. Pizza Stone

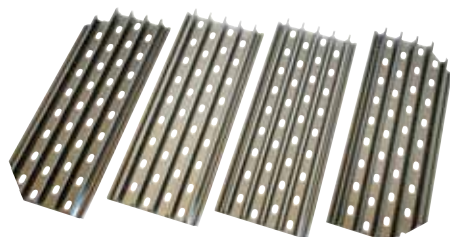

06. Grill Grates

PK ACCESSORIES & GEAR



07. Littlemore Grid

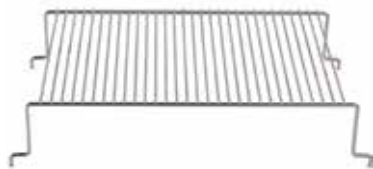

08. Cookmore Grid



09. Apron



10. Navy PK Logo Tee



11. Grey PK Pig Tee



12. Fire & Smoke Society Hat

BUILT TO COOK. BUILT TO LAST

THE SIXTY YEAR OLD START-UP

The first PK Grill & Smoker was created in Tyler, TX in 1952 by an inventor and local businessman named Hilton Meigs. The simple venting system and aluminum construction produced a grill that excelled at both hot and fast grilling and low and slow barbecue cooking. Meigs sold the popular grill all over the mid-south. The company was purchased from Meigs in 1958 and moved operations to Little Rock, Arkansas where they exist today.

Portable Kitchens Inc. was a major producer of charcoal grills during the 1950s and 1960s until a fire, business issues and the unchecked proliferation of disco music halted operations in the 1970s. No PK Grills were produced for nearly three decades when a local attorney and PK enthusiast named Paul James found one at a yard sale in the late 1990s.

As a testament to the durability of the PK Grill, James found the yard sale PK to be fully functioning. After cooking a deliciously moist pork shoulder for his family and a gathering of curious neighbors, he was compelled to commission a mold of the old cast aluminum grill which he then used to begin producing the PK Grill & Smoker again.

Almost forty five years to the day after the first Portable Kitchen grill popped out of its mold in Tyler, Texas, Portable Kitchens was back in business with the PK Grill & Smoker.

In 1952 the PK Grill was the best outdoor cooker money could buy and one could argue that it has remained so over its history. In 2014, Portable Kitchen embarked on a journey to again make the best outdoor cooker your money can buy.

Your new PK360 Grill & Smoker is the result of several years of design and development and over sixty years of outdoor grilling excellence. It is the new generation of PK Grill.

