

WARING®

PROFESSIONAL BELGIAN WAFFLE MAKER

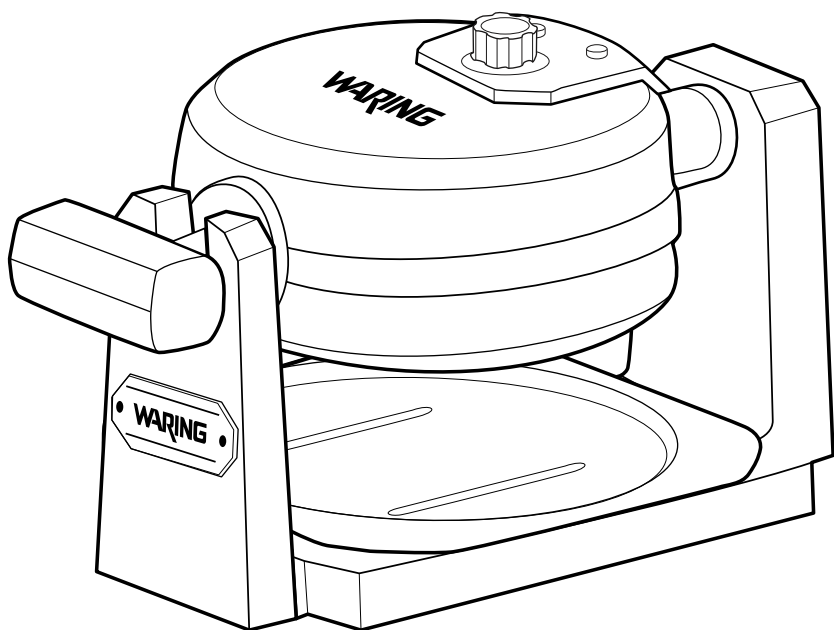

WMK200

For your safety and continued enjoyment of this product,
always read the instruction book carefully before using.

CONGRATULATIONS

on the purchase of your new Waring® Waffle Maker.

CONTENTS

Important Safeguards	2
Polarization Instructions	3
Special Cord Set Instructions	4
Before First Use.....	4
Parts & Features.....	5
Instructions for Use	6
Tips for Making Perfect Belgian Waffles	7
Recipes	8
Cleaning & Maintenance	13

IMPORTANT SAFEGUARDS

When using electrical appliances, basic safety precautions should always be taken, including the following:

1. **READ ALL INSTRUCTIONS.**
2. **Do not touch hot surfaces. Use handles and knobs.**
3. **Unplug from outlet when not in use and before cleaning. Allow to cool before putting on or taking off parts, and before cleaning appliance.**
4. To protect against fire, electrical shock, and injury to persons, **DO NOT IMMERSE CORD, PLUG, OR UNIT** in water or other liquids.
5. Close supervision is necessary when any appliance is used by or near children.
6. Do not operate any appliance with a damaged cord or plug or after the appliance malfunctions or has been damaged in any manner. Return appliance to the nearest Waring Authorized Service Facility for examination, repair, or adjustment.
7. The use of accessory attachments not recommended by Waring may result in fire, electric shock, or injury to persons.
8. Do not use outdoors, or use for other than intended use.

9. Do not let power cord hang over edge of table or counter, or touch hot surfaces.
10. Do not place on or near a hot gas or electric burner, or in a heated oven.
11. Unplug the unit when finished baking waffles.
12. Always begin by plugging appliance into wall outlet. To disconnect, turn control to setting #1, then remove plug from wall outlet.
13. **WARNING: TO REDUCE THE RISK OF FIRE OR ELECTRIC SHOCK, REPAIR SHOULD BE DONE ONLY BY AUTHORIZED PERSONNEL. DO NOT REMOVE THE BASE PANEL. NO USER-SERVICEABLE PARTS ARE INSIDE.**
14. Extreme caution must be used when moving an appliance containing hot oil or other hot liquids.
15. Do not operate your appliance in an appliance garage or under a wall cabinet. **When storing in an appliance garage, always unplug the unit from the electrical outlet.** Not doing so could create a risk of fire, especially if the appliance touches the walls of the garage or the door touches the unit as it closes.

SAVE THESE INSTRUCTIONS FOR HOUSEHOLD USE ONLY

POLARIZATION INSTRUCTIONS

For your protection, the Waring® Professional Belgian Waffle Maker is supplied with a polarized plug (1 blade wider than the other). To reduce the risk of fire, this plug will fit in a polarized outlet only one way. If the plug does not fit fully in the outlet, reverse the plug. If it still does not fit, contact a qualified electrician for assistance. Do not modify the plug in any way.

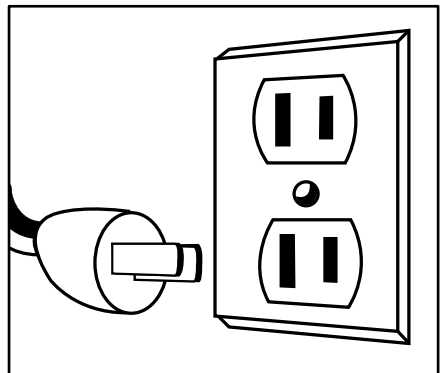

SPECIAL CORD SET INSTRUCTIONS

A short power-supply cord is provided to reduce the risks resulting from becoming entangled in or tripping over a longer cord.

Extension cords may be used if care is exercised in their use. If an extension cord is used, the marked electrical rating of the extension cord should be at least as great as the electrical rating of the appliance, and the longer cord should be arranged so that it will not drape over the countertop or tabletop where it can be pulled on by children or animals, or tripped over. The extension cord should be for a polarized plug and outlet.

This appliance is for 120 volts only and should not be used with a converter.

BEFORE FIRST USE

1. Before using your Waring® Belgian Waffle Maker for the first time, remove any dust from shipping by wiping the plates with a damp cloth. Remove all protective paper and wrapping.

NOTE: The first time you use your Waring® Belgian Waffle Maker; it may have a slight odor and may smoke a bit. This is normal and common to heating appliances.

PARTS & FEATURES

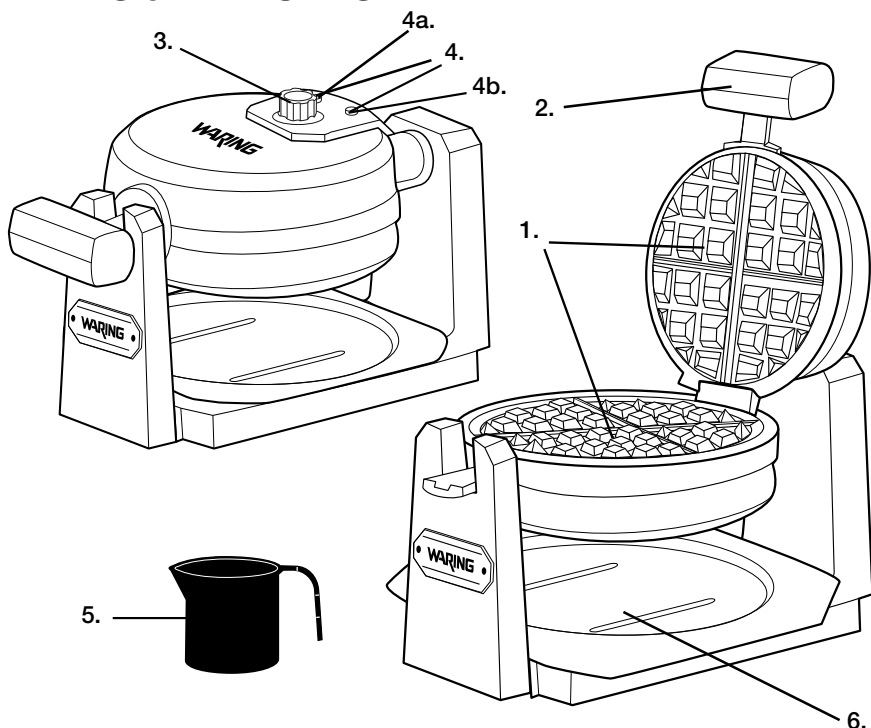

1. **Deep 1-Inch Belgian Waffle Grids** – For restaurant-style waffles in your own home.
2. **Lid Handle** – Used to rotate waffle grids 180°.
3. **Browning Control Dial** – Adjustable from temperature settings 1–6 for different batters and personal preference.
4. **Indicator Lights:**
 - a. **Power light** – Illuminates when the waffle maker is plugged in.
 - b. **Ready lights (top & bottom)** – Illuminate when the waffle grids are preheated and when the baking cycle is complete.
5. **Measuring Cup** – Fill to the top with batter for perfectly measured waffles.
6. **Drip Tray** – Catches any excess batter and is removable for easy cleaning.

All parts that come in contact with food are BPA-free.

INSTRUCTIONS FOR USE

The waffle grids have been treated with a special nonstick PTFE coating. Before the first use, we suggest you season the grids with cooking spray or flavorless vegetable oil. If using oil, apply oil with a paper towel or pastry brush.

1. Plug the cord into a 120V AC wall outlet.
2. To preheat your Waring® Belgian Waffle Maker, turn the control knob dial to setting 5 or preferred setting*. Heat-up time should take approximately four minutes. The Ready indicator light located on the top of the waffle maker will be light up when fully heated. (This is for the first waffle of each baking session.)

NOTE: The first time you use your waffle maker it may have a slight odor and may smoke a bit. This is normal, and common to appliances with a nonstick surface.

3. When the waffle grids are preheated, open the lid. Fill the provided batter cup with batter. If using a standard measuring cup, fill to $\frac{3}{4}$ cup.
4. Pour the batter evenly across the waffle grids. Use a heatproof spatula to spread the batter evenly over the grids. Close the lid and rotate the handle 180° to the right.
5. The Ready light will be on for approximately 30 seconds and then cycle off. When the ready light turns back on, your waffle is ready. NOTE: Baking time is determined by the browning setting chosen. It may take up to 3 minutes to bake your waffles on a higher setting.
6. Once the Ready light has illuminated, rotate the handle 180° to the left and open the lid. To remove the waffle, gently loosen the edges with a heat-proof spatula. Never use stainless utensils, as they may damage the nonstick coating.
7. Repeat the above process if making additional waffles. It is not necessary to spray the waffle grids before each new waffle.

When you are finished baking, always unplug the power cord from the wall outlet. Allow the waffle maker to cool down completely before handling.

*We recommend using setting #5 to achieve a golden-brown baked Belgian waffle. Adjust the browning control if you prefer lighter or darker waffles.

TIPS FOR MAKING PERFECT BELGIAN WAFFLES

Batter Suggestions

- Packaged Belgian waffle mixes found in most supermarkets may be used with this unit.
- For best results, we recommend filling the supplied measuring cup to the top so it will fill the waffle grids
- For evenly filled waffles, pour the batter into the center of the lower grid and spread out evenly to the edges. The entire waffle grid should be filled.
- For added convenience while baking waffles, rest the measuring cup on the lip of the bowl containing the batter until the next baking cycle.

Cooking Suggestions

- We recommend turning the browning control dial to setting #5 when using commercial pancake/waffle mixes and for the included recipes. If you prefer crisper, darker Belgian waffles, set the browning control higher. If you prefer lighter waffles, turn the browning control dial down.
- If waffles tend to stick to waffle grids, add slightly more oil or butter to the batter.
- Belgian waffles taste best when made to order, but baked Belgian waffles may be kept warm in a 200°F oven. Place them in a baking pan or wrap them in foil while in the oven. Waffles wrapped in foil may lose their crispness.
- Baked waffles may be frozen. Allow them to cool completely, and then place them in a plastic food storage bag. Use waxed paper to keep waffles separated. Reheat in an oven, toaster or toaster oven when ready to serve.

Suggested Toppings

- Maple syrup or fruit syrups
- Warm fruit compote or fruit sauce
- Fresh berries or chopped fruit
- Chopped nuts
- Powdered sugar
- Whipped cream
- Ice cream
- Sorbet
- Chocolate sauce
- Fruited yogurt

RECIPES

Classic Belgian Waffles

Classic Belgian waffles have a crispy outside and are soft and moist on the inside. Try these waffles with your favorite syrup or a topping, such as fresh strawberries and freshly whipped cream.

Makes approx. 10 waffles

- 1½ cups water (375ml) (divided)**
- 2¼ teaspoons (one packet) active dry yeast**
- ⅓ cup (5g) sugar**
- 3 cups (300g) sifted flour**
- ¼ teaspoon salt**
- 3 large eggs, separated + 1 egg white**
- 1½ cups (375ml) whole milk**
- 8 tablespoons (15g) unsalted butter – melted and cooled**
- 2 teaspoons vegetable oil**
- 2 teaspoons pure vanilla extract**

Heat half of the water to lukewarm, 105°–110°F (40–45°C). Dissolve the yeast in the water with a pinch of the sugar from the recipe; let stand 5 to 10 minutes, until the mixture begins to foam.

Put the flour and salt into a large bowl; stir to blend and reserve. Add the egg yolks, one of the egg whites, and remaining sugar to the yeast mixture; stir to blend. Add the remaining water, milk, melted butter, oil, and vanilla; stir until the mixture is smooth. Stir the liquid mixture into the flour mixture and beat until the mixture is smooth.

Beat the egg whites until stiff peaks form. Fold the egg whites gently into the batter. Let the batter stand for 1 hour, stirring every 15 minutes.

Preheat your Waring® Belgian Waffle Maker on setting #5 or preferred setting* (Ready light will illuminate when preheated).

Use the measuring cup to measure the batter and pour into the preheated waffle grids. Use a heatproof spatula to spread the batter evenly over the grids. Close lid and rotate waffle maker 180° to the right. Bake the waffles until the Ready light turns off and then on again. Rotate waffle maker 180° to the left. Remove waffle and repeat until all batter is used. For best results, do not open waffle maker during cooking process.

Waffles may be kept warm in a low (200°F/95°C) oven. Arrange waffles on a cookie sheet on a rack in the warm oven. Serve with whipped cream, fruit, jam, powdered sugar, or a warm fruit syrup.

*We recommend using setting #5 to achieve a golden-brown baked Belgian waffle. Adjust the browning control if you prefer lighter or darker waffles.

Nutritional information per waffle:

*Calories 300 (40% from fat) • carb. 37g • pro. 8g • fat 13g
sat. fat 7g • chol. 94mg • sod. 104mg • calc. 61mg • fiber 1g*

Gingerbread Belgian Waffles

These waffles have the flavor of just-baked gingerbread, and are delicious served with fresh fruit or caramelized apples and pears.

Makes approx. 6 waffles

- ½ cup (125ml) warm water**
- 1 teaspoon granulated sugar**
- 2¼ teaspoons (1 packet) active dry yeast**
- 1½ cups (150g) all-purpose flour**
- 1 cup (about 50g) graham cracker crumbs**
- ¼ cup (50g) granulated sugar**
- ¼ teaspoon salt**
- 1 teaspoon ground ginger**
- ½ teaspoon finely chopped lemon zest**
- 2 cups (500ml) warm milk (about 105°F)**
- 3 large eggs, separated**
- ½ cup (115g) unsalted butter, melted and cooled**
- 1 teaspoon pure vanilla extract**

Measure the water into a large bowl. Add 1 teaspoon granulated sugar and yeast; stir to dissolve. Let stand 10 minutes. In a separate bowl, combine the flour, graham cracker crumbs, ¼ cup sugar, salt, ginger, and lemon zest; stir to combine; reserve. Add the milk, egg yolks, melted cooled butter, and vanilla to the yeast mixture. Stir until smooth. Add the dry ingredients and beat until smooth, using a hand mixer on low speed. Cover with waxed paper and let stand to rise in a warm, draft-free place for 30 minutes. Beat the egg whites until stiff, but not dry. Gently fold them into the batter.

Preheat your Waring® Belgian Waffle Maker on setting #5 or preferred setting* (ready light will illuminate when preheated).

Use the measuring cup to measure out batter, spreading evenly into waffle grids. Close lid and rotate 180° to the right and bake the waffles until the Ready light turns off and then on again. Rotate waffle maker 180° to the left. Remove waffle and repeat with remaining batter. For best results, do not open waffle maker during cooking process.

Waffles may be kept warm in a low (200°F/95°C) oven. Arrange waffles on a cookie sheet on a rack in the warm oven. Serve with lemon curd, fruit, jam, powdered sugar, a warm fruit syrup, or whipped cream.

*We recommend using setting #5 to achieve a golden-brown baked Belgian waffle. Adjust the browning control if you prefer lighter or darker waffles.

Nutritional information per waffle:

*Calories 458 (44% from fat) • carb. 23g • pro. 11g • fat 23g
sat. fat 12g • chol. 159mg • sod. 279mg • calc. 120mg • fiber 1g*

Good Night Waffles

Most of the mixing for these waffles is done the night before. In the morning, just mix in the eggs, vanilla extract and a pinch of baking soda while the waffle maker is heating. Leftover batter may be covered and kept in the refrigerator for up to 3 days. Heat your waffle maker in the morning, stir the batter and have a freshly baked waffle for breakfast. Makes approx. 6 waffles

- ½ cup (125ml) lukewarm (105°F) water**
- 1 tablespoon granulated sugar**
- 2¼ teaspoons (1 packet) active dry yeast**
- 2 cups (500ml) whole milk, warmed (about 105°F)**
- ½ cup (115g) unsalted butter, melted and cooled**
- 1 teaspoon salt**
- 2 cups (200g) all-purpose flour**
- 2 large eggs, lightly beaten**
- 2 teaspoons pure vanilla extract**
- ¼ teaspoon baking soda**

The night before, or at least 8 hours before baking, combine the warm water, granulated sugar and yeast. Let stand 10 minutes, until foamy. Stir in the warm milk, melted butter and salt. Beat in the flour until smooth; (this may be done using a hand mixer on low speed).

Wrap bowl tightly with plastic wrap and let stand overnight (or for 8 hours) on the countertop; do not refrigerate.

When ready to bake, preheat your Waring® Belgian Waffle Maker on setting #5 or preferred setting* (Ready light will illuminate when preheated).

While the waffle maker is heating, stir the eggs, vanilla extract and baking soda into the batter. Use measuring cup to measure out batter. Pour into waffle grids. Use a heat-proof spatula to spread the batter evenly over the grids. Close cover and rotate 180° to the right. Bake the waffles until the Ready light turns off and then on again. Rotate 180° to the left. Remove waffle and repeat with remaining batter. For best results, do not open waffle maker during cooking process

Waffles may be kept warm in a low (200°F/95°C) oven. Arrange waffles on a cookie sheet on a rack in the oven. Serve with sliced fresh fruit, jam, powdered sugar, a warm fruit syrup, or whipped cream.

*We recommend using setting #5 to achieve a golden-brown baked Belgian waffle. Adjust the browning control if you prefer lighter or darker waffles.

Nutritional information per waffle:

*Calories 373 (49% from fat) • carb. 38g • pro. 10g • fat 20g
sat. fat 12g • chol. 123mg • sod. 501mg • calc. 117mg • fiber 1g*

Pumpkin Nut Belgian Waffles

These waffles taste like freshly baked pumpkin muffins and are delicious served with warm maple syrup. Makes approx. 6 waffles

- 1½ cups (150g) all-purpose flour**
- 1 ounce (30g) finely chopped walnuts or pecans (best if toasted first)**
- 1 tablespoon cornstarch**
- 1 tablespoon baking powder**
- 1 teaspoon salt**
- 1 teaspoon ground cinnamon**
- ½ teaspoon ground ginger**
- ¼ teaspoon freshly ground nutmeg**
- ¾ cup (about 150g) pumpkin purée (canned solid-pack pumpkin)**
- 2 large eggs, separated**
- 1 cup whole milk**
- ¼ cup (250ml) real maple syrup (do not use pancake syrup)**
- 3 tablespoons (10g) unsalted butter, melted**
- 1 teaspoon pure vanilla extract**
- 3 large egg whites**

In a large bowl, combine the flour, chopped nuts, cornstarch, baking powder, salt, cinnamon, ginger, and nutmeg. Stir to blend and reserve. In a second bowl, combine the pumpkin purée, egg yolks, milk, maple syrup, melted butter, and vanilla extract; stir until smooth. Add the liquid ingredients to the dry ingredients and stir to blend until smooth, using a whisk. In a clean, dry bowl, beat the egg whites until stiff peaks form. Gently fold the beaten egg whites into the batter. Preheat your Waring® Belgian Waffle Maker on setting #5 or preferred setting* (ready light will illuminate when preheated).

Use measuring cup to measure out batter. Pour into waffle grids. Use a heat-proof spatula to spread the batter evenly over the grids. Close cover and rotate 180° to the right. Bake the waffles until the Ready light turns off and then on again. Rotate 180° to the left. Remove waffle and repeat with remaining batter. For best results, do not open waffle maker during cooking process.

Waffles may be kept warm in a low (200°F/95°C) oven. Arrange waffles on a cookie sheet on a rack in the oven. Serve with warm maple syrup, powdered sugar, or whipped cream.

*We recommend using setting #5 to achieve a golden-brown baked Belgian waffle. Adjust the browning control if you prefer lighter or darker waffles.

Nutritional information per waffle:

*Calories 303 (35% from fat) • carb. 40g • pro. 10g • fat 12g
sat. fat 5g • chol. 92mg • sod. 579mg • calc. 94mg • fiber 2g*

CLEANING & MAINTENANCE

Once you have finished baking, remove plug from electrical outlet. Leave the top lid open and allow grids to cool before cleaning.

Never take your Belgian waffle maker apart for cleaning. Simply brush crumbs from grooves, and absorb any excess cooking oil by wiping with a dry cloth or paper towel. You may clean the grids by wiping with a damp cloth to prevent staining and sticking from batter or oil buildup.

Be certain grids have cooled completely before cleaning. If batter adheres to plates, simply pour a little cooking oil onto the baked batter and let stand approximately 5 minutes, thus allowing batter to soften for easy removal.

To clean exterior, wipe with a soft dry cloth. Never use an abrasive cleanser or harsh pad. **NEVER IMMERSE CORD, PLUG OR UNIT IN WATER OR OTHER LIQUIDS.**

Hand-wash drip tray.

Any other servicing should be performed by an authorized service representative.

**Trademarks or service marks of third parties used herein are
the trademarks or service marks of their respective owners.**

**©2013 Waring Consumer Products
150 Milford Road
East Windsor, NJ 08520
www.waringpro.com**

**Printed in China
WMK200 IB
13WR141089**

IB-12136