

PARTS

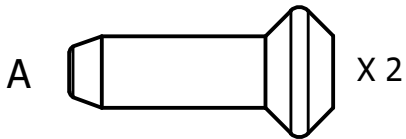

$\frac{3}{4}$ " X 2 Adirondack Pin

FOLDED POSITION FOR STORAGE

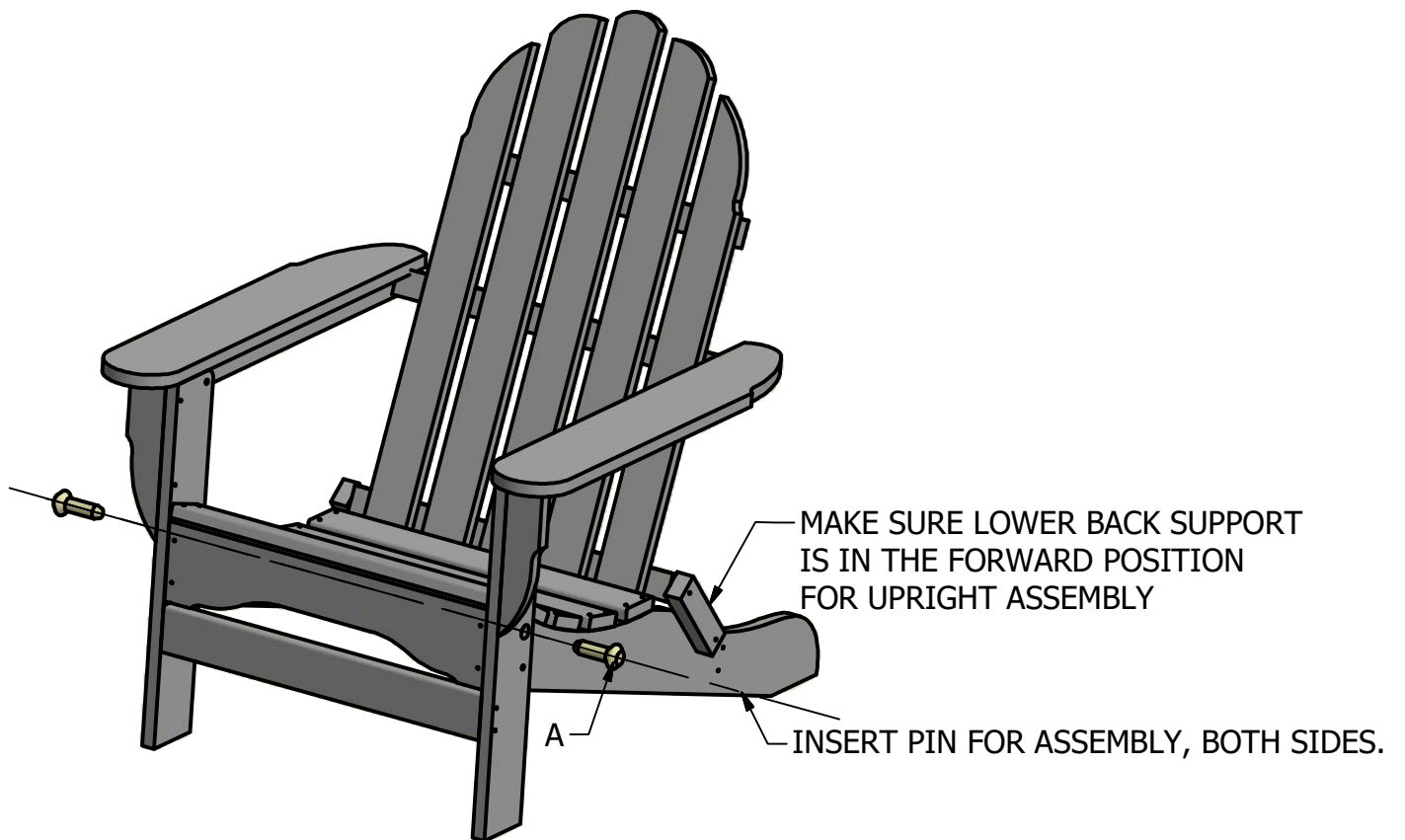
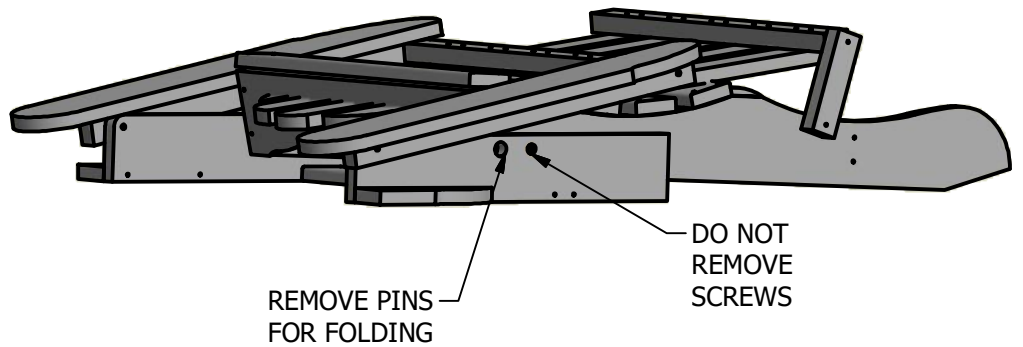

ASSEMBLY FOR UPRIGHT POSITION



STEP 1
Rotate legs to down position

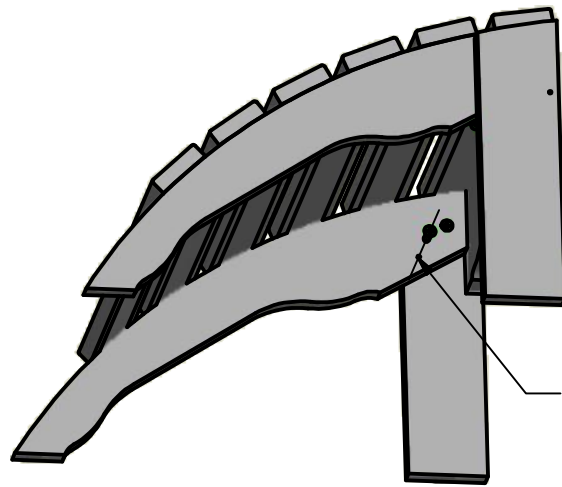

STEP 2
Insert (1) 1-1/4" screw to the
inside of both front legs

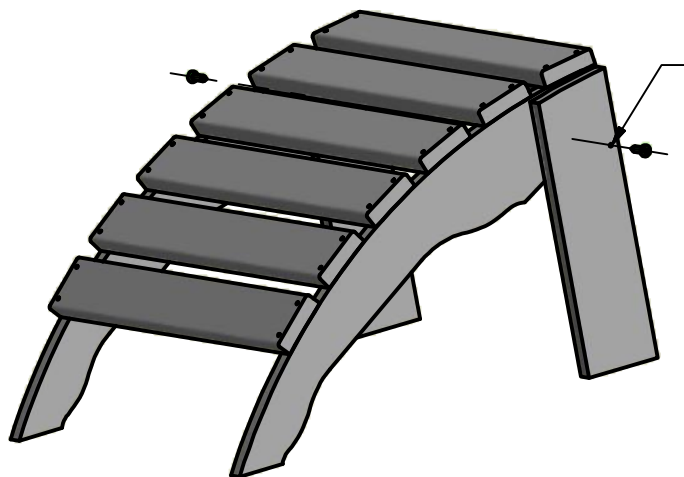

STEP 3
Insert (1) 1-1/4" screw to the
outside of both front legs

Tools needed:
Phillips screwdriver
(4) - 1-1/4" Phillips wood screws (included)



Step 1:
Lay tabletop upside down and attach leg assemblies using (8) 2" screws
Note: Do not fully tighten screws

Make sure braces are facing outward

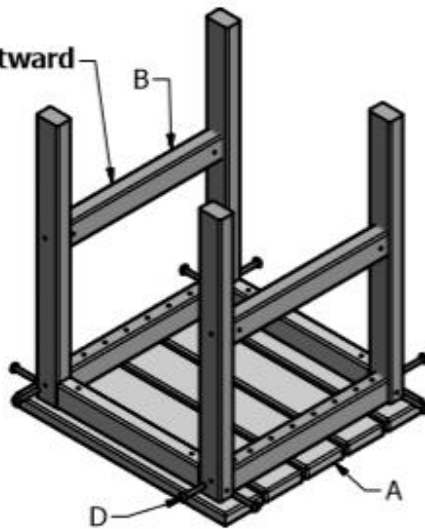

Step 2:
Loosely attach braces using the remaining (4) 2" screws
Next, turn table upright and tighten all screws

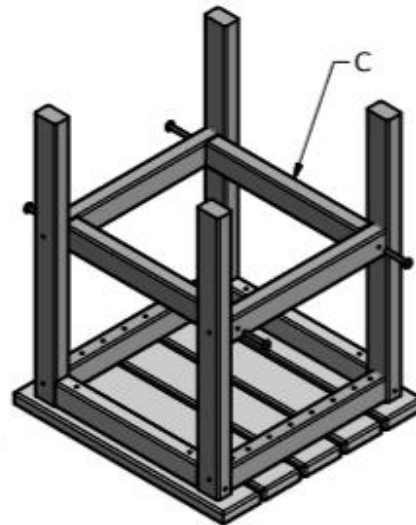

Included Items:

- A. (1) Table top assembly
- B. (2) Leg assemblies
- C. (2) Leg cross braces
- D. (12) 2" Phillip head screws

Tools Needed:

Phillips screwdriver