

Model XPH12 M/R/Z Parts List

A = Standard Equipment

O = Circuit Diagram

Item#	Part#	Description	Q'ty	Unit
001	183E71-3	HOUSING SET	1	
	C10 263005-3	RUBBER PIN 6	2	PC.
	C20 252126-6	HEX. LOCKING NUT M4-7	2	PC.
	D10	INC. 21		
002	852L95-9	XPH12 NAME PLATE	1	
003	266429-2	TAPPING SCREW 3X16	7	PC.
004	419041-9	F/R CHANGE LEVER	1	PC.
005	650710-5	SWITCH C3JW-4B	1	
006	619406-7	ROTOR	1	
007	629225-3	STATOR	1	
008	620549-0	LED CIRCUIT	1	
009	643874-2	TERMINAL	1	PC.
010	123738-1	SPEED CHANGE LEVER ASSEMBLY	1	
	C10 233438-6	COMPRESSION SPRING 4	2	PC.
011	251497-8	TAPPING SCREW 3X20	4	
012	251468-5	- FLAT HEAD SCREW M6X22	1	PC.
013	766027-7	KEYLESS DRILL CHUCK 13	1	
014	123736-5	GEAR ASSEMBLY	1	
015	266490-9	TAPPING SCREW PT 2X6	3	PC.
016	620548-2	CONTROLLER	1	
017	652069-6	FLAT HEAD SCREW M3X6	3	PC.
018	424517-3	CUSHION	1	PC.
019	456966-6	REAR COVER	1	
020	809U04-3	CAUTION LABEL	1	
021	183E71-3	HOUSING SET	1	
	C10 263005-3	RUBBER PIN 6	2	PC.
	C20 252126-6	HEX. LOCKING NUT M4-7	2	PC.
	D10	INC. 1		
022	266429-2	TAPPING SCREW 3X16	2	PC.
A01	251314-2	+ SCREW M4X12	1	PC.
A02	346449-3	HOOK	1	PC.
A04	158597-4	PLASTIC CASE COMPLETE	1	PC. (XPH12M/R)
	C10 417724-5	LATCH	2	PC. (XPH12M/R)
A05	450128-8	BATTERY COVER	1	PC. (XPH12M/R)
A06	***DC18RC	DC18RC FAST CHARGER	1	PC. (XPH12M/R)
	D10	COMPO-PARTS		
A07	BL1840B	BATTERY BL1840B SET	2	(XPH12M)
	BL1820B	BATTERY BL1820B SET	2	(XPH12R)

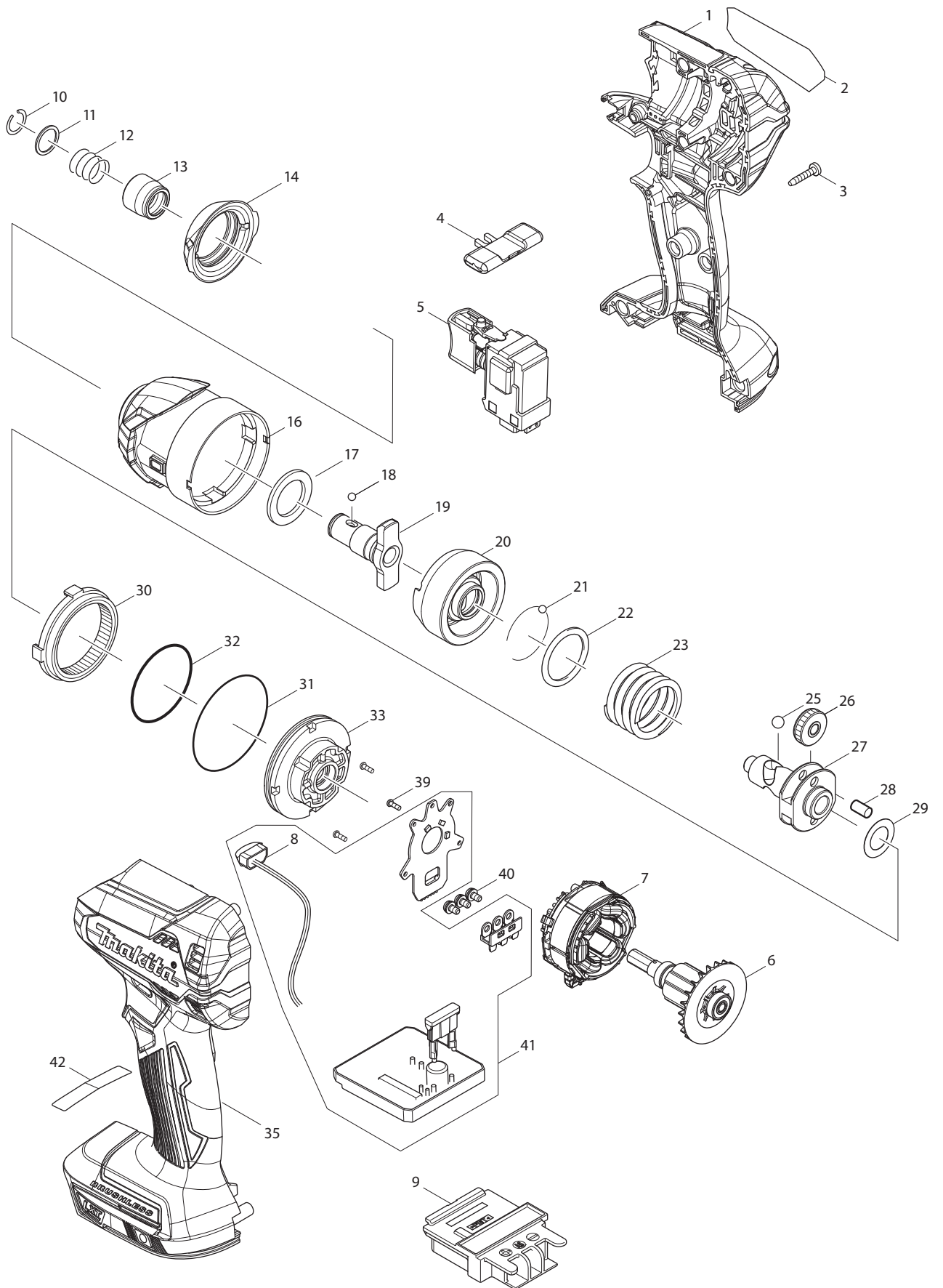

Model XDT13M/R/Z Parts List

A = Standard Equipment

O = Circuit Diagram

Item#	Part#	Description	Q'ty	Unit
001	183E34-9	HOUSING SET	1	
	C10 263005-3	RUBBER PIN 6	2	PC.
	C20 252126-6	HEX. LOCKING NUT M4-7	2	PC.
	D10	INC. 35		
002	852K78-3	XDT13 NAME PLATE	1	
003	266429-2	TAPPING SCREW 3X16	9	PC.
004	455053-8	F/R CHANGE LEVER	1	PC.
005	143975-1	SWITCH COMPLETE	1	
006	619404-1	ROTOR	1	
007	629224-5	STATOR	1	
008	620557-1	LED CIRCUIT	1	
009	643860-3	TERMINAL	1	PC.
010	231951-8	RING SPRING 11	1	PC.
011	267085-1	FLAT WASHER 12	1	PC.
012	233005-7	COMPRESSION SPRING 13	1	PC.
013	326068-1	BIT SLEEVE	1	PC.
014	424888-8	BUMPER	1	
016	143957-3	HAMMER CASE COMPLETE	1	
017	261151-6	NYLON WASHER 19	1	PC.
018	216040-0	STEEL BALL 3.5	2	PC.
019	326563-1	ANVIL M	1	
020	326564-9	HAMMER	1	
021	216040-0	STEEL BALL 3.5	24	PC.
022	267175-0	FLAT WASHER 24	1	PC.
023	234251-5	COMPRESSION SPRING 25	1	PC.
025	216041-8	STEEL BALL 5.6	2	
026	227362-3	SPUR GEAR 22	2	PC.
027	326562-3	SPINDLE	1	
028	256253-1	PIN 5	2	PC.
029	253314-8	THIN WASHER 15	1	PC.
030	227378-8	INTERNAL GEAR 51	1	
031	213606-7	O RING 48	1	PC.
032	213507-9	O RING 40	1	PC.
033	143958-1	BEARING BOX COMPLETE	1	
035	183E34-9	HOUSING SET	1	
	C10 263005-3	RUBBER PIN 6	2	PC.
	C20 252126-6	HEX. LOCKING NUT M4-7	2	PC.
	D10	INC. 1		
039	266490-9	TAPPING SCREW PT 2X6	3	PC.
040	652069-6	FLAT HEAD SCREW M3X6	3	PC.
041	620556-3	CONTROLLER	1	
	D10	INC. 8		
042	809R90-6	CAUTION LABEL	1	
A01	266622-8	+ TRUSS HEAD SCREW M4X12	1	PC.
A02	346449-3	HOOK	1	PC.
A03	450128-8	BATTERY COVER	1	PC. (XDT13M/R)
A04	***DC18RC	DC18RC FAST CHARGER	1	PC. (XDT13M/R)
	D10	COMPO-PARTS		
A05	BL1840B	BATTERY BL1840B SET	2	(XDT13M)

	BL1820B	BATTERY BL1820B SET	2	(XDT13R)
A06	141856-3	PLASTIC CARRYING CASE COMPLETE	1	PC. (XDT13M/R)
C10	162302-3	LATCH	2	PC. (XDT13M/R)

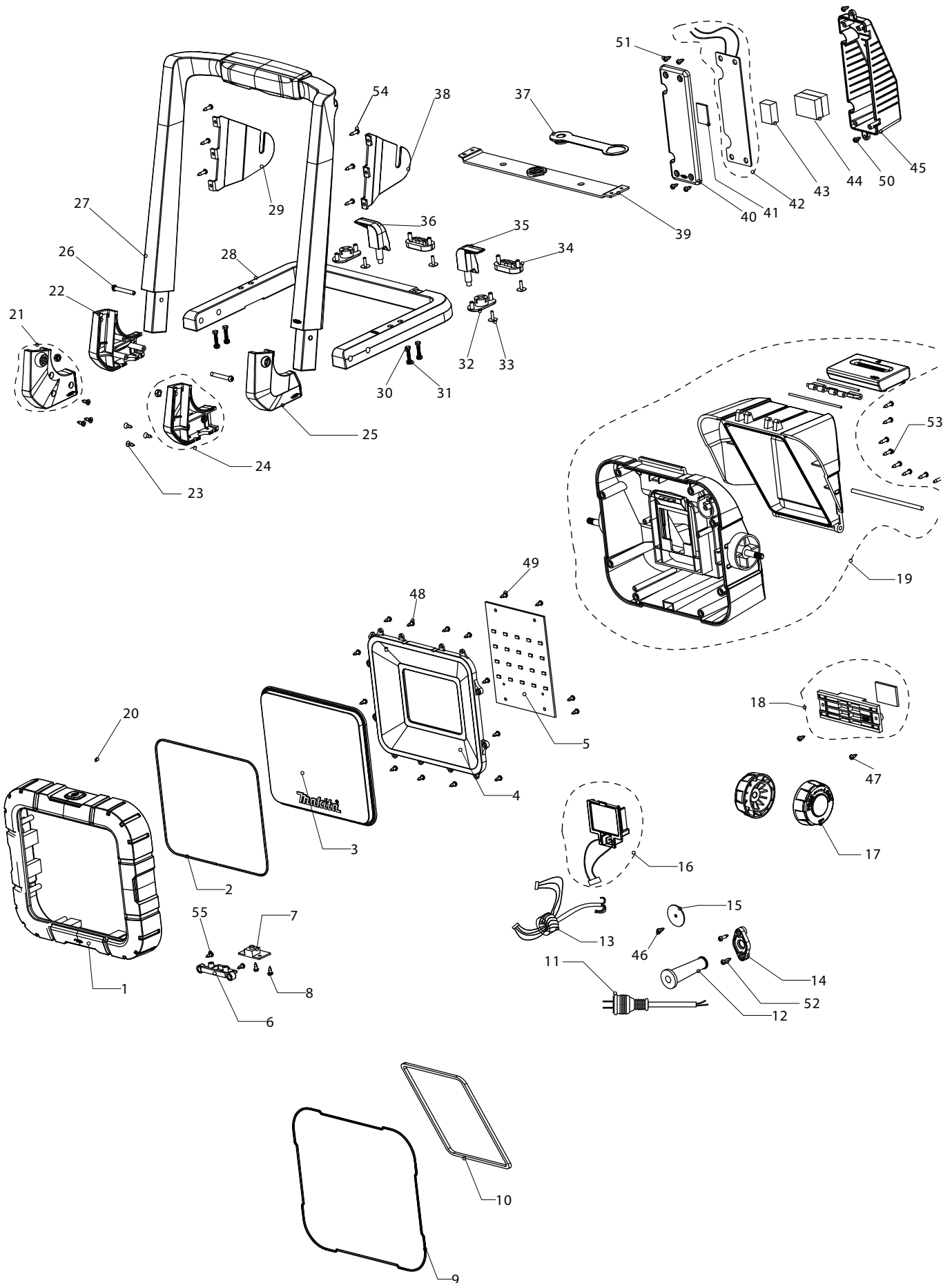

Model DML805 Parts List

A = Standard Equipment

O = Circuit Diagram

Item#	Part#	Description	Q'ty	Unit
001	GM00001356	HOUSING(FRONT) ROS88050100	1	
002	GM00001353	PACKING C9020805002	1	
003	GM00001378	LENS ROS88052000	1	
004	GM00001358	REFLECTOR ROS88050300	1	
005	GM00001359	LED CIRCUIT ROS88050400	1	
006	GM00001341	SWITCH BRACKET C2820805007	1	
007	GM00001360	SWITCH CIRCUIT ROS88050500	1	
008	GM00001332	SCREW 3 X 8 PB B0130080702	2	
009	GM00001354	PACKING C9020805003	1	
010	GM00001352	PACKING C9020805001	1	
011	GM00001423	POWER SUPPLY CORD	1	
012	GM00001416	CORD GUARD	1	
013	GM00001361	LEAD WIRE ASSY ROS88050600	1	
014	GM00001344	CORD CLAMP C2820805010	1	
015	GM00001338	CORD HOLDER B0405805120	1	
016	GM00001362	BATTERY HOLDER ROS88050700	1	
017	GM00001342	KNOB C2820805008	2	
018	GM00001363	FIX PLATE ASSY ROS88050800	1	
019	GM00001379	BATTERY COVER ASSY ROS88051900	1	
020	GM00001343	SWITCH ROD C2820805009	1	
021	GM00001371	BRACKET LR ASSY ROS88051600	1	
022	GM00001345	BRACKET LL C2820805013	1	
023	GM00001334	SCREW 3 X 12 KA B0130120721	6	
024	GM00001372	BRACKET RL ASSY ROS88051700	1	
025	GM00001346	BRACKET RR C2820805016	1	
026	GM00001336	SCREW PM4X29 B0140290704	2	
027	GM00001365	FRAME ROS88051000	1	
028	GM00001366	BASE ROS88051100	1	
029	GM00001367	HANGER L ROS88051200	1	
030	GM00001335	SCREW M3 X18 B0130180754	4	
031	GM00001337	NUT M3 B0203007000	4	
032	GM00001350	FOOT (FRONT) C7420805002	2	
033	GM00001331	SCREW 2.6 X 10 PWB B0126100706	4	
034	GM00001351	FOOT (BACK) C7420805003	2	
035	GM00001347	CORD HOOK(R) C2820805017	1	
036	GM00001348	CORD HOOK (L) C2820805018	1	
037	GM00001349	ADAPTER C5220805001	1	
038	GM00001368	HANGER R ROS88051300	1	
039	GM00001369	UNDER STAND ROS88051400	1	
040	GM00001340	HOUSING (BOTTOM) C1920805002	1	
041	GM00001374	PAD(A) A3255201501	1	
042	GM00001415	POWER CIRCUIT ASSY	1	
043	GM00001328	PAD(B) A3255201300	1	
044	GM00001375	PAD(C) A3255252501	1	
045	GM00001376	HOUSING (TOP) C1920805003	1	
046	GM00001332	SCREW 3 X 8 PB B0130080702	1	
047	GM00001332	SCREW 3 X 8 PB B0130080702	2	
048	GM00001332	SCREW 3 X 8 PB B0130080702	12	
049	GM00001332	SCREW 3 X 8 PB B0130080702	4	

050	GM00001332	SCREW 3 X 8 PB B0130080702	2
051	GM00001332	SCREW 3 X 8 PB B0130080702	4
052	GM00001333	SCREW 3 X 12PB B0130120702	2
053	GM00001333	SCREW 3 X 12PB B0130120702	8
054	GM00001333	SCREW 3 X 12PB B0130120702	6
055	GM00001333	SCREW 3 X 12PB B0130120702	2