



12 X 18 INCH DOLLY (TWO PACK)

MODEL 721218

SPECIFICATIONS

Maximum Dynamic Load:	660 lbs
Maximum Static Load:	1000 lbs
Product Dimensions:	18 x 11.5 x 5-1/4 inch
Product Weight:	6.8 lbs

⚠ WARNINGS

1. Do not climb, sit or stand on the dolly.
2. Do not exceed the loading capacity.
3. Do not use the dolly if any part is missing or damaged. Replace damaged parts immediately.

ASSEMBLY INSTRUCTIONS

1. Remove all 16 nuts (B) pre-installed on the base of the dolly using an 11mm socket or wrench.
2. Install the caster (A) onto the four screws (C) on the corner of the dolly.
3. Secure the caster using the four nuts (B) and tighten the nuts using an 11mm socket or wrench.
4. Repeat with all four casters. Check that all the nuts are tightened and the casters have been properly installed before operating the dolly.

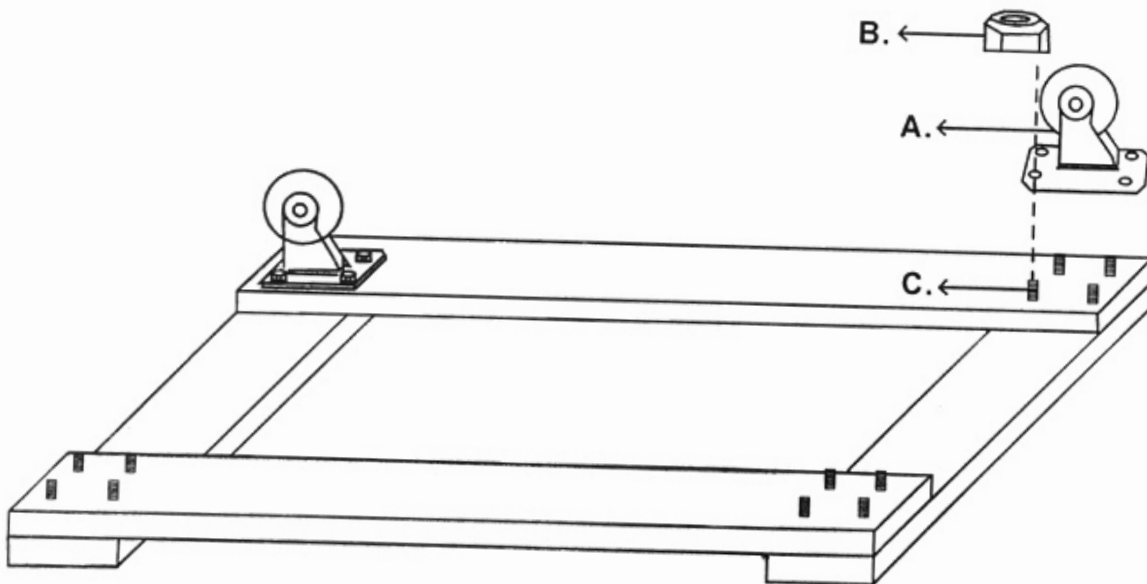

PARTS LIST

NO.	PART NO.	DESCRIPTION	QTY.
A	721218-001	Caster	4
B	721218-002	Nut M6	16
C	721218-003	Bolt M6x48	16

For replacement parts visit WENPRODUCTS.COM

NEED HELP? CONTACT US!

Have product questions? Need technical support?
Please feel free to contact us at:

800-232-1195 (M-F 8-5 CST)

techsupport@wenproducts.com

WENPRODUCTS.COM