



CONGRATULATIONS!
You have purchased
a product made in
Quebec, Canada



ORLÉANS



USER'S GUIDE

ORLEANS™

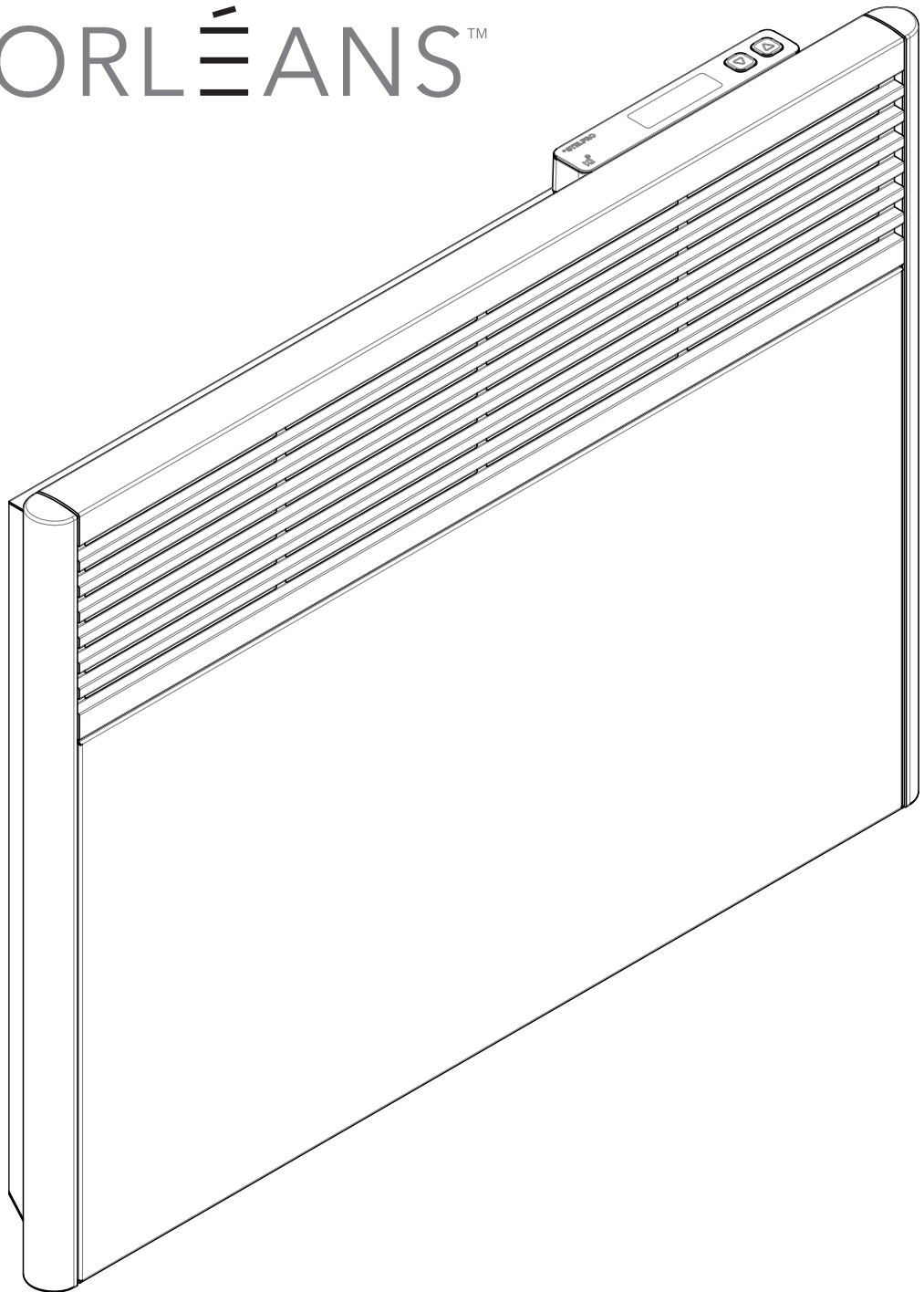

ASOR SERIES HIGH-END CONVECTOR

REPLACEMENT COMPONENT LIST INCLUDED



This unit complies
with CSA and UL
standards





IMPORTANT INSTRUCTIONS

Before installing and operating this product, the user and/or installer must read, understand and follow these instructions and keep them handy for future reference. If these instructions are not followed, the warranty will be considered null and void and the manufacturer deems no further responsibility for this product.

This product must be installed by a qualified person and connected by a **certified electrician**, according to the **electrical and building codes** effective in your region.

The following instructions must be adhered to in order to avoid personal harm or property damages, serious injuries and potentially fatal electric shocks.

Protect the heating unit with the appropriate circuit breaker or fuse, in accordance with the nameplate.

Make sure the line voltage (volt) is consistent with that indicated on the unit's nameplate.

This unit must be **grounded**.

Switch off the power at the circuit breaker/fuse before installing, repairing and cleaning the unit.

Make sure the unit is appropriate for the intended use (if needed, refer to the product catalog or a representative). Use this heater only as described in this manual. Any other use not recommended by the manufacturer may cause fire, electric shock, or injury to persons. Do not use outdoors.

RECOMMENDED HEATING CAPACITY: 1.25 W/cubic foot (0.03 m³)

It corresponds to **10 W/square foot (0.09 m²)** based on a standard ceiling height of **8 feet (2.44 m)**. The recommended capacity is usually sufficient for normal heating needs. Please note that the insulation quality of walls and windows are some of the factors that influence heat losses, which modify the required capacity to heat a room. If needed, refer to a specialist who will be able to calculate these heat losses and optimize the required capacity or consult the "Online heating calculation" section of the Stelpro website (residential buildings). To heat a large room and to increase your comfort, it is recommended to install several units instead of one. For example, 2 X 1000 W rather than 1 X 2000 W.

Do not install the unit where objects or pieces of furniture could be heat damaged.

If the unit's capacity is insufficient for the size of the room, it will be in operation continuously, and may become defective earlier and turn yellow.

Respect distances and positions indicated in the installation section.

If the installer or user modifies the unit, they will be held responsible for any damage resulting from this modification, and the CSA certification could be void.

This unit must not come into contact with a water source and must be protected from splashes (e.g. a wet mop). Do not use it if any part has been immersed. Moreover, do not turn it on or off when standing in water or if your hands are wet.

When mounting the unit, make sure that the anchorage used can support the total weight of the unit with the mounting brackets.

When cutting or drilling into a wall, do not damage electrical wiring and other hidden utilities.

When starting up the unit for the first time or after a long period, it is normal that it produces some temporary odours and whitish smoke.

Because this unit is hot when in use, it may pose risks even in normal operation. Therefore, be **careful and responsible** when using it. To avoid burns, do not let bare skin touch hot surfaces. Let the unit cool down for a few minutes before handling it (it stays warm for some time after shut-down). Extreme caution is necessary when any heater is used by or near children or invalids and whenever the heater is left operating and unattended.

CAUTION – High temperature; risk of fire. Keep electrical cords, drapery, furnishings, and other combustibles at least 3 feet (0.9 m) from the front of the heater and away from the side and rear.

The bottom of this unit must be installed at least **4 inches (10.2 cm)** from any adjacent surfaces, and **4 inches (10.2 cm)** from the floor. However, make sure objects or pieces of furniture such as, but not limited to, blankets, towels, beds, laundry baskets, clothing, papers, etc. do not come into contact with the unit and keep them at least **12 inches (30.5 cm)** from the unit since they are more flammable than walls and floors. Failure to comply with this warning could lead to a fire. Some materials are more heat-sensitive than others, so make sure those near the unit can withstand heat.

Do not install on a wall behind a door.

Never block the air vents. This obstruction could lead to overheating, which could result in a fire.

Do not insert or allow foreign objects to enter any air vent as this may cause electric shocks, a fire or damages to the unit.

This unit has hot and arcing or sparking parts inside. It is not designed to be used or stored in wet areas or areas containing flammable liquids, combustible materials or corrosive, abrasive, chemical, explosive and flammable substances such as, but not limited to, gasoline, paint, chlorine, sawdust and cleaning products.

Some areas are dustier than others. Thus, it is the user's responsibility to evaluate if the unit **must be cleaned** based on the amount of dirt accumulated on and inside air vents. Accumulated dirt can lead to a component malfunction or give a yellowish color to the unit. Failure to install and maintain the unit in accordance with these instructions poses a fire hazard.

Thermal protection activation indicates that the unit has been subjected to abnormal operating conditions. If the thermal protection remains activated or activates and deactivates repeatedly, it is recommended that a qualified electrician or a certified repair centre examine the unit in order to make sure it is not damaged. (Refer to the limited warranty.)

Before unplugging the unit, all controls must be in the "OFF" position and the current from the main breaker panel should be cut. (The general switch may be used also, if included.) If the unit is damaged or defective, discontinue use, cut off power supply at circuit breaker and contact a certified electrician or certified repair centre. (Refer to the limited warranty)

If the unit is damaged or defective, cut off the power supply at the circuit breaker and call a certified repair centre. (Refer to the limited warranty)

Note: When a part of the product specification must be changed to improve operability or other functions, priority is given to the product specification itself. In such instances, the instruction manual may not entirely match all the functions of the actual product. Therefore, the actual product and packaging, as well as the name and illustration, may differ from the manual. The screen/LCD display shown as an example in this manual may be different from the actual screen/LCD display. This unit must be used with the provided thermostat.

SPECIFICATIONS & TECHNICAL DRAWINGS

MODEL	WATTS	VOLTS	LENGTH		KG	LB
			MM	IN.		
HIGH MODELS - HEIGHT: 708 mm (27 7/8 in.)						
ASORH1002	1000/750	240/208	457	18	6.8	15.1
ASORH1502	1500/1125	240/208	623	24 1/2	8.8	19.4
ASORH2002	2000/1500	240/208	768	30 1/4	10.5	23.2
LOW MODELS - HEIGHT: 330 mm (13 in.)						
ASORL1002	1000/750	240/208	750	29 1/2	5.2	11.5
ASORL1502	1500/1125	240/208	1113	38 7/8	6.9	15.1
ASORL2002	2000/1500	240/208	1276	50 1/4	8.3	18.3
STANDARD MODELS - HEIGHT: 455 mm (17 7/8 in.)						
ASOR0502	500/375	240/208	457	18	4.8	10.7
ASOR1002	1000/750	240/208	597	23 1/2	6	13.2
ASOR1502	1500/1125	240/208	743	29 1/4	7.2	15.9
ASOR2002	2000/1500	240/208	895	35 1/4	9.7	21.4

Add **W** for white or **SW** for silica white

BUILT-IN THERMOSTAT TECHNICAL SPECIFICATIONS	
DISPLAYED TEMPERATURE RANGE	0 °C TO 50 °C (32 °F TO 122 °F)
TEMPERATURE DISPLAY RESOLUTION	0.5 °C (1 °F)
SETPOINT RANGE	5 °C TO 30 °C (41 °F TO 86 °F)
SETPOINT INCREMENTS	0.5 °C (1 °F)
STORAGE TEMPERATURE RANGE	-50 °C TO 50 °C (-58 °F TO 122 °F)
OPERATING TEMPERATURE*	-20 °C TO 50 °C (-4 °F TO 122 °F)

* The LCD display may not function normally at temperatures below 0 °C (32 °F)

TECHNICAL DRAWINGS

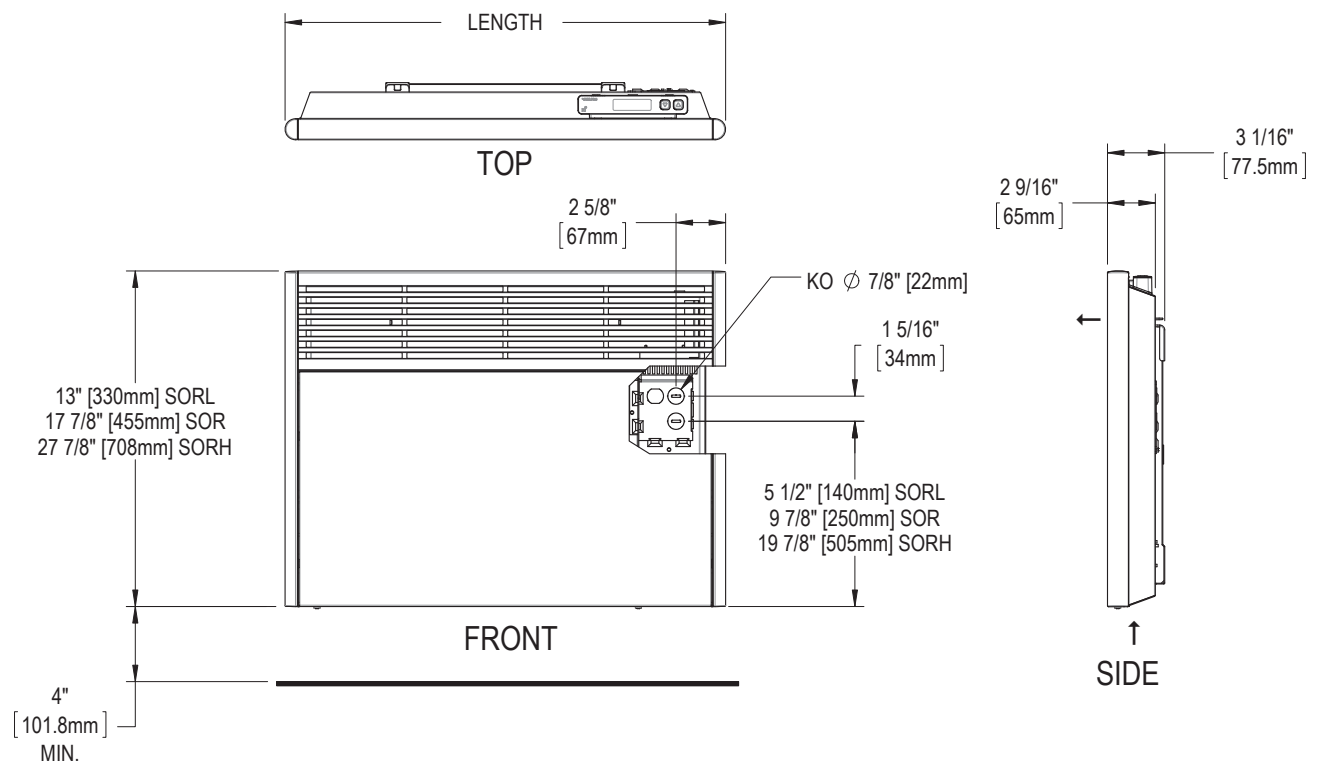



INSTALLATION & ELECTRIC WIRING

N.B. Cut off power supply at circuit breaker/fuse before proceeding with the installation. To reduce the risk of fire, do not store or use gasoline or other flammable vapors and liquids in the vicinity of the heater. Do not mount in contact with combustible material. Do not mount in close proximity to another unit.

CAUTION – High temperature; risk of fire. Keep electrical cords, drapery, furnishings, and other combustibles at least 3 feet (0.9 m) from the front of the heater and away from the side and rear.

- The unit should be installed at least 4 in. (10.2 cm) from the floor and 6 in. (15 cm) from adjacent walls.
- Before operating the unit, make sure that both the air inlet (bottom) and the air outlet (front) are free from obstruction.

INSTALLATION OF WALL RACK

1. Release the unit from the wall rack by depressing the hooks.
2. Place the wall rack on the floor and against the wall where the unit is to be installed.
3. Using a pencil and the holes provided in the wall rack, make marks on both sides of the rack at the desired height for the bottom of the wall rack. Although not mandatory, please note that the positioning of the unit makes installation easier with the use of the pre-cut holes.
4. Securely fasten the rack to the wall, making sure that it is level. When drilling into the wall, make sure not to damage any electrical wiring or other hidden objects.

N.B. The wall where you install this rack must be straight so that the bracket remains flat once installed without having to apply any pressure. If the rack is not flat once installed, the hooking mechanism could be compromised and the convector could unexpectedly release from its rack.

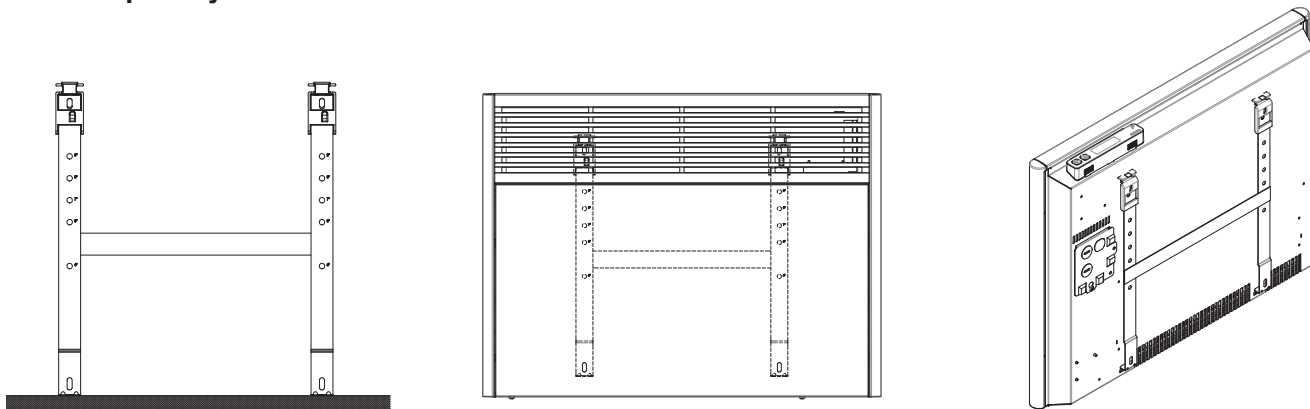

THE BOTTOM OF THIS UNIT MUST BE INSTALLED AT LEAST **4 INCHES (10.2 CM)** FROM THE FLOOR.

INSTALLATION OF CONVECTOR ON WALL RACK

1. Insert the lower hooks of the wall bracket into the lower slots on the rear of the convector.
2. Engage the hooks of the wall rack into the upper slots on the rear of the convector.
3. Push on the convector to make sure that it is fully engaged with the wall rack. You should hear the hooks engage when pressure is applied to the upper front of the convector.

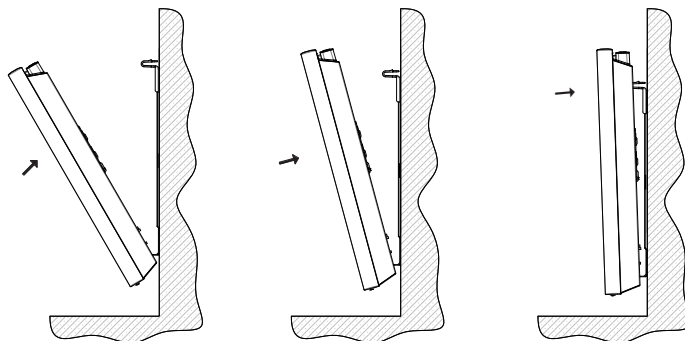

ELECTRIC WIRING

The supply wires must be connected in accordance with all effective building and electrical codes. The bare (ground) wire must be connected to the green wire in the convector using an appropriate wire nut. The supply wires (from the electrical panel) must be connected to the wires labelled "L1" and "L2" in the convector using appropriate wire nuts.

N.B. This product must be connected by a qualified electrician as per the wiring diagram to the right and in accordance with building and electrical codes effective in your area.

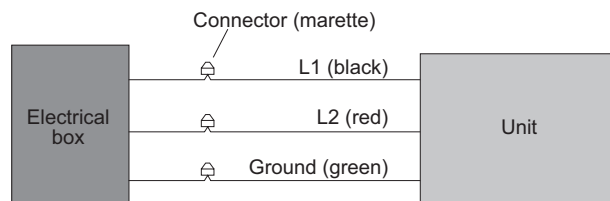

OPERATION

BUILT-IN ELECTRONIC THERMOSTAT FOR SMART HOMES (ST218)



ADJUSTING THE TEMPERATURE SETPOINT

- By pressing either button on the thermostat, the temperature setpoint will be displayed as flashing digits.
- The temperature setpoint is set by using the UP (▲) or DOWN (▼) buttons to raise or lower the setpoint respectively by increments of 0.5 °C (1 °F) each time the buttons are pressed. Holding down either button will allow you to scroll more quickly to the desired temperature setpoint.
- Once the desired setpoint has been selected, release the button. This setpoint will remain in memory for the current mode (COMFORT or ECO (ECO) – see next section for details). The display will stop flashing after 3 seconds and will then display the ambient temperature in the room.
- In order to sensitize the user about energy consumption, the color of the contour around the buttons will change according to the setpoint selected; green being a lower setpoint and red being a higher setpoint.

NOTE #1: In no heat mode, the setpoint displayed is (--) and the (❄) icon is displayed indicating that there is a potential risk of freezing. In this mode, it is not possible to modify the setpoint. If a new setpoint is sent from the smart home controller while the convector is in no heat mode, the thermostat will return to COMFORT mode.

NOTE #2: The setpoint in ECO mode is local to the convector. In other words, its setpoint cannot be set by the smart home controller. If a new setpoint is sent via the smart home controller while the convector is in ECO (ECO) mode, the thermostat will return to COMFORT mode.

NOTE #3: If a setpoint change is sent by the smart home controller, the display will flash this setpoint on the thermostat for 3 seconds and then return to normal.

SELECTING THE OPERATION MODE

There are three (3) operation modes: COMFORT mode, ECO mode (identified by the (ECO) icon) and NO HEAT mode (identified by the (❄) icon). To switch from one mode to another, simply press and then release both buttons simultaneously

NOTE #1: If the operation mode is changed remotely by the smart home controller, the setpoint (or (--) when in NO HEAT mode) will be displayed for 3 seconds and will then return to normal.

NOTE #2: Once the ECO mode has been selected, the convector will respect the ECO mode setpoint for the duration as configured (see ECO MODE DURATION section for details). Once the duration for ECO mode has elapsed (unless NO HEAT is selected), the convector will automatically return to COMFORT mode.

THERMOSTAT DISPLAY

- Ambient room temperature (or the setpoint when flashing)
- Operation mode: COMFORT, ECO (ECO), NO HEAT (❄)
- The (❄) icon indicates a freezing risk either due to a low setpoint or if the thermostat is set to NO HEAT. This icon will flash if an open window is detected.
- The thermostat displays the percentage of heating time required to maintain the desired temperature.
 - 0 segments: 0%
 - 1 segment: 1-25%
 - 2 segments: 26-50%
 - 3 segments: 51-75%
 - 4 segments: 76-100%
- The status of the connectivity with the ZigBee (📶) network.
- The (🔒) is displayed when the controls are locked. See LOCKING THE CONTROLS for details.



BUTTON FUNCTIONS

BUTTONS	DISPLAY	ADVANCED MENUS
SINGLE BUTTON	ADJUSTMENT OF TEMPERATURE SETPOINT	NAVIGATION AND EDITING OF PARAMETERS
BOTH BUTTONS SIMULTANEOUSLY	MODE SELECTION (COMFORT, ECO, NO HEAT)	SELECTION AND CONFIRMATION OF PARAMETERS
BOTH BUTTONS HELD SIMULTANEOUSLY FOR 3 SECONDS	ACCESS TO ADVANCED MENUS	EXIT FROM ADVANCED MENU

ZIGBEE CONNECTIVITY



This convector is compatible with the ZigBee smart home protocol. Once connected, it can be controlled remotely by means of the application included with the user's ZigBee controller.

FOLLOW THESE STEPS TO CONNECT YOUR CONVECTOR TO A ZIGBEE NETWORK:

- Make sure that the ZigBee controller is in ASSOCIATION mode
- Access the advanced menus
- Select menu 1 ()
- If ON is selected, the convector will find the channel assigned to the ZigBee network. You can also manually specify the channel that your ZigBee controller is currently using. The ZigBee connection process will be faster if the ZigBee channel is manually specified.
- During the association, your selection will flash rapidly and the connectivity icon () will be animated
- Once the association with the ZigBee network has been established, the channel number will be shown on the display

- If an error occurs during association, (ERR) will be displayed for 3 seconds followed by (NO HEAT) being displayed

FOLLOW THESE STEPS TO DISCONNECT YOUR CONVECTOR FROM THE ZIGBEE NETWORK:

- Access the advanced menus
- Select menu 1 ()
- Change the parameter to (NO HEAT)
- During the disassociation, (NO HEAT) will flash rapidly and the connectivity icon () will be animated
- Once the disassociation with the ZigBee network has been completed, (NO HEAT) will be displayed
- If an error occurs during disassociation, (ERR) will be displayed for 3 seconds followed by the channel number being displayed

TEMPERATURE FORMAT

The temperature can be displayed in either degrees Celsius or Fahrenheit.

Follow these steps to select the temperature format:

- Access the advanced menus
- Select menu 2
- Select either °C or °F

DISPLAY BACKLIGHTING

Both the display backlighting as well as the lighted control buttons can be configured. When either button is pressed, the buttons are lit with a color (see ADJUSTING THE TEMPERATURE SETPOINT for details of colors displayed) and the display will be at 100% brightness. If no button is pressed for 15 seconds, the display can behave in one of three ways:

- 1 - ALL: The display backlighting is active but dimmed. The button contours remain colored
- 2 - BTN: The backlighting is off. The button contours remain colored.

- 3 - OFF: The backlighting is off. The button contours are colored light gray
- Follow these steps to configure the backlighting and button behavior:

- Access the advanced menus
- Select menu 3 ()
- Select ALL, BTN or OFF

NOTE: The display backlighting and the button contours will be at 100% intensity if a problem is detected with the ZigBee communication or if a window is open.

LOCKING THE CONTROLS

This mode allows you to lock the controls in order to prevent unwanted changes to the setpoint and/or operation modes.

While the () icon is displayed, only changes sent by the ZigBee controller are possible.

NOTE: The advanced menus remain accessible at all times.

Follow these steps to activate or deactivate the control lock:

- Access the advanced menus
- Select menu 4 ()
- Select (ON) or (NO HEAT)

OPEN WINDOW DETECTION

This convector can detect an open window in the room and lower the setpoint so as not to waste energy.

When the convector detects an open window in the room, the () icon will flash and the button contours will flash in blue. The setpoint will be automatically set to 7 °C (45 °F).

Once the convector detects that the window has been closed, the setpoint will return to its previous setting.

Follow these steps to activate or deactivate the open window detection:

- Access the advanced menus
- Select menu 5 ()
- Select (ON) or (NO HEAT)

ECO MODE DURATION ECO

By default, the ECO (ECO) mode duration is set to (NO HEAT). In other words, the mode selection is permanent and the convector will remain in ECO mode unless another mode is manually selected or selected remotely by the smart home controller.

Follow these steps to modify the duration of the ECO (ECO) mode:

- Access the advanced menus
- Select menu 6 (ECO)
- Select the duration from the values available ranging from:
 - 1-12 hrs, in one hour increments
 - 14 hrs
 - 16 hrs
 - 18 hrs
 - 1-7 days, in one day increments

OPERATION & MAINTENANCE

°STELPRO MENU

Information about the convector is available in this menu. It is also possible to reset the convector to its factory settings (menu 7.7).

Follow these steps to access this information:

- Access the advanced menus
- Select menu 7
- Select one of the following sub-menus:
 - 7.1 : Version of convector
 - 7.2 : Version of ZigBee 'radio'
 - 7.3 : Day manufactured
 - 7.4 : Month manufactured
 - 7.5 : Year manufactured
 - 7.6 : Internal control code
 - 7.7 : Factory reset of convector

FREEZE PROTECTION ❄️

The (❄️) icon will be displayed when the thermostat is adjusted between 5 °C (41 °F) and 7 °C (45 °F) and indicates that the ambient room temperature will not drop below the freezing point.

BUTTON CONTOUR COLORS

BUTTON CONTOUR COLORS	CONVECTOR CONDITION
GREEN	NORMAL OPERATION, ECONOMICAL TEMPERATURE SETPOINT
BETWEEN GREEN AND RED	NORMAL OPERATION, THE COLOR REFLECTS HOW ECONOMICAL THE TEMPERATURE SETPOINT IS; MORE GREEN IS MORE ECONOMICAL AND MORE RED IS LESS ECONOMICAL.
RED	NORMAL OPERATION, HIGH TEMPERATURE SETPOINT
BLUE	CONVECTOR IN 'NO HEAT' MODE
FLASHING BLUE	OPEN WINDOW DETECTED
WHITE	WHILE IN ADVANCED MENUS
GRAY	WHEN THE BACKLIGHTING IS SET TO 'NO HEAT' AND THE BUTTONS REMAIN INACTIVE FOR MORE THAN 15 SECONDS

NO HEAT MODE

See the SELECTING THE OPERATION MODE section for procedure to activate the NO HEAT mode.

NOTE #1 : There is still voltage present in the convector and there is a risk of electric shock even if the NO HEAT mode is activated. Always switch the circuit breaker off prior to servicing or cleaning the convector.

NOTE #2 : The convector will NEVER heat when in the NO HEAT mode. A freeze risk is present when the NO HEAT mode is activated.

FACTORY RESET

Follow these steps to reset the convector to its factory settings:

- Access the advanced menus
- Select menu 7
- Select sub-menu 7.7. Confirm selection when (def) is displayed
- Select (yes) and confirm the selection
- (yes) will blink for few seconds and the convector will be reset to its factory settings



MAINTENANCE

N.B. In order for the warranty on this product to remain valid, it must be cleaned on a regular basis.

Always cut off the power at the breaker or fuse prior to cleaning the unit. Use a soft rag to dust the unit or a damp cloth to clean it. In order to prevent yellowing and/or damage to the product finish, do not use cleaning products (chemical or abrasive). Regularly use a vacuum brush to remove dust and any other foreign objects from the grill if the product is installed in a very dusty area.

NOTE: Cigarette smoke can accelerate the yellowing of the discharge grill. More frequent cleanings are recommended in these conditions.

N.B. High voltage and the risk of electric shock are present in the unit even if the thermostat is set to OFF.

STAINLESS STEEL CLEANING TIPS

Although stainless steel is corrosion resistant, its finish can still be damaged. It is recommended to clean the stainless steel surfaces on a regular basis and not to wait until a full cleaning is necessary. Since the acidity level and chlorine content of regular cleaning agents

vary greatly, it is highly recommended to thoroughly rinse the surface with clean water following their use. Stainless steel polishes can also be used and are recommended. Always polish the stainless steel surfaces with the grain and never against the grain.



DO NOT USE

- chlorine or chlorine-based cleaners
- scrubbing pads or other scrubbing devices (steel wool)
- abrasive cleaning agents
- hydrochloric acid-based products such as bleach: they can stain and/or damage stainless steel surfaces

Do not use cleaning products identified with these symbols:



TROUBLESHOOTING

PROBLEM	DEFECTIVE PART OR PART TO CHECK
The unit does not work	<ul style="list-style-type: none"> - Defective thermostat - Open circuit breaker or fuse - Thermal protection activated - Faulty connections
The unit runs continuously	<ul style="list-style-type: none"> - Defective wall mounted thermostat - Heat losses greater than the unit capacity
The housing is extremely hot	<ul style="list-style-type: none"> - Defective thermal protection - Blocked air vents
The desired room temperature cannot be reached	<ul style="list-style-type: none"> - One or more defective elements - Defective wall mounted thermostat - Voltage lower than indicated on the nameplate - Heat losses greater than the unit capacity
Overheating	<ul style="list-style-type: none"> - Defective wall mounted thermostat - Setpoint is set too high
The unit cycles under control of the thermal protection (overheat indicator)	<ul style="list-style-type: none"> - Blocked air vents
The heater is on and the breaker trips	<ul style="list-style-type: none"> - Faulty connections - Voltage higher than that indicated on the nameplate
The unit does not heat	<ul style="list-style-type: none"> - One or more elements in the unit are defective - Defective temperature probe - Temperature setpoint set too low - No heat mode activated - Open window detected - Defective wall thermostat
The connectivity icon () is flashing on the display	- There is a problem with the ZigBee 'radio'. Reinitialize the convector.
The temperature setpoint and/or the operation mode cannot be modified	- The unit is locked. Deactivate the control lock ()

N.B. If you do not solve the problem after checking these points, cut off the power supply at the main electrical panel and contact our customer service (please refer to the Limited Warranty to obtain the phone numbers)

ERROR CODE	DEFINITION
LO	Temperature lower than 0 °C (32 °F), the unit will always heat unless set to NO HEAT
HI	Temperature higher than 50 °C (122 °F), the unit will never heat
--	<ul style="list-style-type: none"> - If displayed in place of the temperature setpoint: NO HEAT mode activated, heating not possible - If displayed in place of the ambient temperature: defective temperature probe, heating not possible. Call customer service for assistance.
Err	The connection to the ZigBee network has failed. Ensure that the unit is within range of the ZigBee controller and that it is in ASSOCIATION mode.
E1	Defective auxiliary temperature probe. The unit will still control the temperature, but the performance of the thermostat may be diminished. Call customer service for assistance.

REPLACEMENT COMPONENT LIST

MODEL	HOUSING	FRONT PANEL	WALL SUPPORT	THERMAL PROTECTION (AUTO.)	ELEMENT (TYPE X)	THERMOSTAT CONTROL	THERMOSTAT POWER SUPPLY
	1	2	3	4	5	6	7
ASOR0502	M-SOR0500A*	M-SOR0500B*	M-SOR0500C0	PROT-055	ELF-SOR0201X	ST-218	CIR-044
ASOR1002	M-SOR1000A*	M-SOR1000B*	M-SOR1000C0	PROT-057	ELF-SOR0501X		
ASOR1502	M-SOR1500A*	M-SOR1500B*	M-SOR1500C0	PROT-057	ELF-SOR0701X		
ASOR2002	M-SOR2000A*	M-SOR2000B*	M-SOR2000C0	PROT-057	ELF-SOR1001X		
ASORH1002	M-SORH1000A*	M-SORH1000B*	M-SORH1000C0	PROT-058	ELF-SORH0501X		
ASORH1502	M-SORH1500A*	M-SORH1500B*	M-SORH1500C0	PROT-058	ELF-SORH0701X		
ASORH2002	M-SORH2000A*	M-SORH2000B*	M-SORH2000C0	PROT-058	ELF-SORH1001X		
ASORL1002	M-SORL1000A*	M-SORL1000B*	M-SORL1000C0	PROT-058	ELF-SORL1002X		
ASORL1502	M-SORL1500A*	M-SORL1500B*	M-SORL1500C0	PROT-058	ELF-SORL1502X		
ASORL2002	M-SORL2000A*	M-SORL2000B*	M-SORL2000C0	PROT-058	ELF-SORL2002X		

* Add **W** for white or **SW** for silica white

NOTE: LOW MODEL has only one element

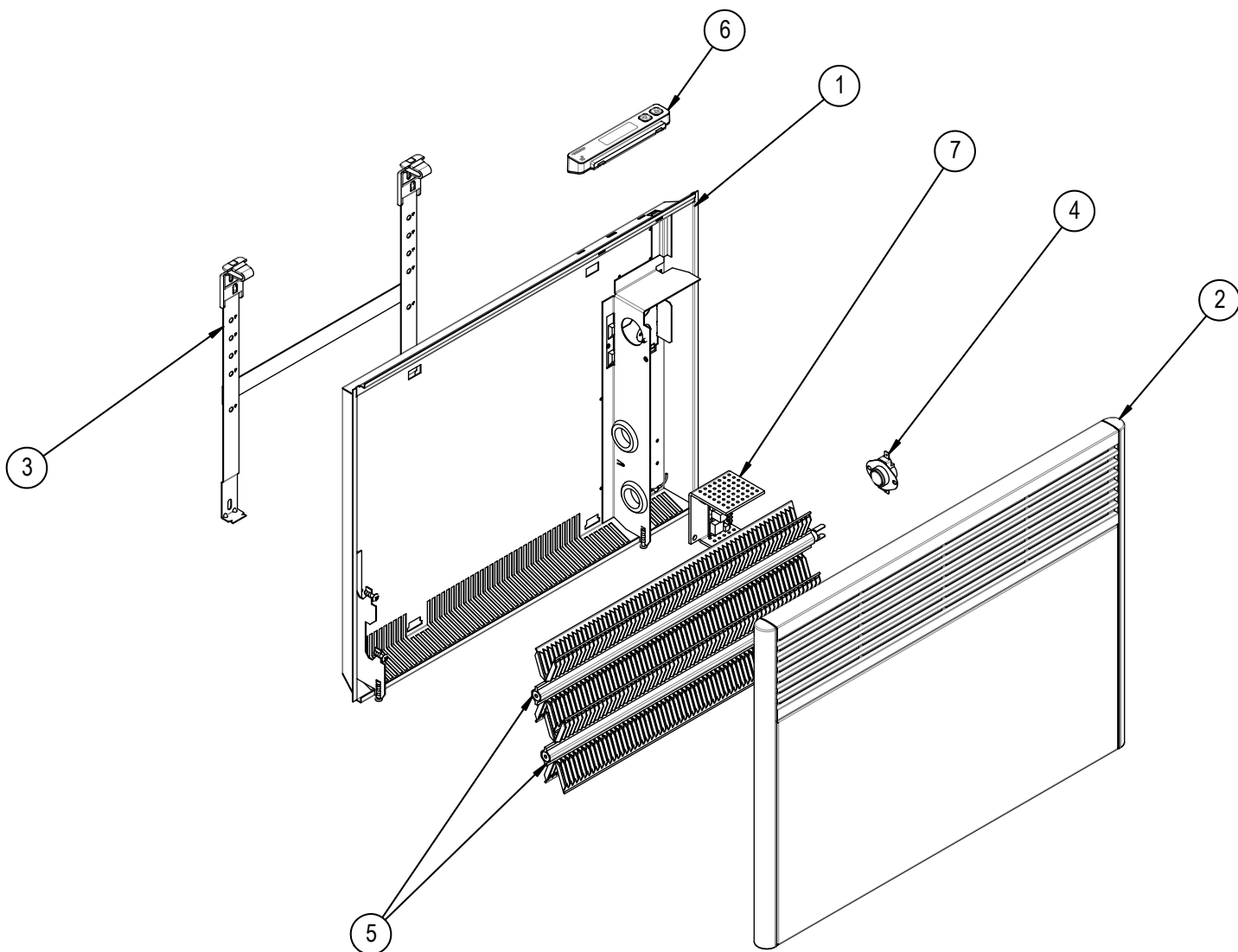

LIMITED WARRANTY

This limited warranty is offered by Stelpro Design inc. ("Stelpro") and applies to the following product made by Stelpro: ASOR model. **Please read this limited warranty carefully.** Subject to the terms of this warranty, Stelpro warrants its products and their components against defects in workmanship and/or materials for the following periods from the date of purchase: **5 years (3 years on electronic components)**. This warranty applies only to the original purchaser; it is non-transferable and cannot be extended.

CLAIM PROCEDURE

If at any time during the warranty period the unit becomes defective, you must cut off the power supply at the main electrical panel and contact 1) your installer or distributor, 2) your service center or 3) Stelpro's customer service department. In all cases, you must have a **copy of the invoice** and provide the **information written on the product nameplate**. Stelpro reserves the right to examine or to ask one of its representatives to examine the product itself or any part of it before honoring the warranty. Stelpro reserves the right to replace the entire unit, refund its purchase price or repair a defective part. Please note that repairs made within the warranty period must be authorized in advance in writing by Stelpro and carried out by persons authorized by Stelpro.

Before returning a product to Stelpro, you must have a Stelpro authorization number (RMA). To obtain it, call the customer service department at: **1-800-363-3414** (electricians and distributors - French), **1-800-343-1022** (electricians and distributors - English), or **1-866-766-6020** (consumers). The authorization number must be clearly written on the parcel or it will be refused.

CONDITIONS, EXCLUSIONS AND DISCLAIMER OF LIABILITY

This warranty is exclusive and in lieu of all other representations and warranties (except of title), expressed or implied, and Stelpro expressly disclaims and excludes any implied warranty of merchantability or implied warranty of fitness for a particular purpose.

Stelpro's liability with respect to products is limited as provided above. Stelpro shall not be subject to any other obligations or liabilities whatsoever, whether based on contract, tort or other theories of law, with respect to goods or services furnished by it, or any undertakings, acts or omissions relating thereto. Without limiting the generality of the foregoing, Stelpro expressly disclaims any liability for property or personal injury damages, penalties, special or punitive damages, damages for lost profits, loss of use of equipment, cost of capital, cost of substitute products, facilities or services, shutdowns, slowdowns, or for other types of economic loss or for claims of a dealer's customers or any third party for such damages. Stelpro specifically disclaims all consequential, incidental and contingent damages whatsoever.

This warranty does not cover any damages or failures resulting from: 1) a faulty installation or improper storage; 2) an abusive or abnormal use, lack of maintenance, improper maintenance (other than that prescribed by Stelpro) or a use other than that for which the unit was designed; 3) a natural disaster or an event out of Stelpro's control, including, but not limited to, hurricanes, tornadoes, earthquakes, terrorist attacks, wars, overvoltage, flooding, water damages, etc. This warranty does not cover any accidental or intentional losses or damages, nor does it cover damages caused by negligence of the user or owner of the product. Moreover, it does not cover the cost of disconnection, transport, and installation.

The warranty is limited to the repair or the replacement of the unit or the refund of its purchase price, **at the discretion of Stelpro**. Any parts replaced or repaired within the warranty period with the written authorization of Stelpro will be warranted for the remainder of the original warranty period. This warranty will be considered null and void and Stelpro will have the right to refuse any claims if **products have been altered** without the written authorization of Stelpro and if the nameplate numbers have been removed or modified. This warranty does not cover scratches, dents, corrosion or discoloration caused by excessive heat, chemical cleaning products and abrasive agents. It does not cover any damage that occurred during the shipping.

Some states and provinces do not allow the exclusion or limitation of incidental or consequential damages and some of them do not allow limitations on how long an implied warranty lasts, so these exclusions or limitations may not apply to you. This warranty gives you specific legal rights and you may have other rights which vary from state to state or from province to province.